



Petsch Respiratory Services

Call Us – Relax – Breathe Easier

104 S. Belair Road #8

Martinez GA 30907

PHONE 706-863-6252 FAX 706-863-2337

www.petschrespiratory.com

Questions and Answers: Jaundice and Your Newborn

Congratulations on the birth of your new baby!

To make sure your baby's first week is safe and healthy, it is important that:

1. Your baby is checked for jaundice in the hospital.
2. If you are breastfeeding, you get the help you need to make sure it is going well.
3. If your baby is discharged before age 72 hours, your baby should be seen by a doctor or nurse within 2 days of discharge from the hospital.

Q: What is jaundice?

A: Jaundice is the yellow color seen in the skin of many newborns. It happens when a chemical called *bilirubin* builds up in the baby's blood. Jaundice can occur in babies of any race or color.

Q: Why is jaundice common in newborns?

A: Everyone's blood contains bilirubin, which is removed by the liver. Before birth, the mother's liver does this for the baby. Most babies develop jaundice in the first few days after birth because it takes a few days for the baby's liver to get better at removing bilirubin.

Q: How can I tell if my baby is jaundiced?

A: The skin of a baby with jaundice usually appears yellow. The best way to see jaundice is in good light, such as daylight or under fluorescent lights. Jaundice usually appears first in the face and then moves to the chest, abdomen, arms, and legs as the bilirubin level increases. The whites of the eyes may also be yellow. Jaundice may be harder to see in babies with darker skin color.

Q: Can jaundice hurt my baby?

A: Most babies have mild jaundice that is harmless, but in unusual situations the bilirubin level can get very high and might cause brain damage. This is why newborns should be checked carefully for jaundice and treated to prevent a high bilirubin level.

Q: How should my baby be checked for jaundice?

A: If your baby looks jaundiced in the first few days after birth, your baby's doctor or nurse may use a skin or blood test to check your baby's bilirubin level. A bilirubin level is always needed if jaundice develops before the baby is 24 hours old. Whether a test is needed after that depends on the baby's age, the amount of jaundice, and whether the baby has other factors that make jaundice more likely or harder to see.

Q: Does breastfeeding affect jaundice?

A: Jaundice is more common in babies who are breastfed than babies who are formula-fed, but this occurs mainly in newborns who are not nursing well. If you are breastfeeding, you should nurse your baby at least 8 to 12 times a day for the first few days. This will help you produce enough milk and will help to keep the baby's bilirubin level down. If you are having trouble breastfeeding, ask your baby's doctor or nurse or a lactation specialist for help. Breast milk is the ideal food for your baby.

Q: When should my newborn get checked after leaving the hospital?

A: It is important for your baby to be seen by a nurse or doctor when the baby is between 3 and 5 days old, because this is usually when a baby's bilirubin level is highest. This is why, if your baby is discharged before age 72 hours, your baby should be seen within 2 days of discharge. The timing of this visit may vary depending on your baby's age when released from the hospital and other factors.



Petsch Respiratory Services

Call Us – Relax – Breathe Easier

104 S. Belair Road #8

Martinez GA 30907

PHONE 706-863-6252 FAX 706-863-2337

www.petschrespiratory.com

Questions and Answers: Jaundice and Your Newborn (continued)

Q: Which babies require more attention for jaundice?

A: Some babies have a greater risk for high levels of bilirubin and may need to be seen sooner after discharge from the hospital. Ask your doctor about an early follow-up visit if your baby has any of the following:

- A high bilirubin level before leaving the hospital
- Early birth (more than 2 weeks before the due date)
- Jaundice in the first 24 hours after birth
- Breastfeeding that is not going well
- A lot of bruising or bleeding under the scalp related to labor and delivery
- A parent, brother, or sister who had high bilirubin and received light therapy

Q: When should I call my baby's doctor?

A: Call your baby's doctor if

- Your baby's skin turns more yellow.
- Your baby's abdomen, arms, or legs are yellow.
- The whites of your baby's eyes are yellow.
- Your baby is jaundiced and is hard to wake, fussy, or not nursing or taking formula well.

Q: How is harmful jaundice prevented?

A: Most jaundice requires no treatment. When treatment is necessary, placing your baby under special lights while he or she is undressed will lower the bilirubin level. Depending on your baby's bilirubin level, this can be done in the hospital or at home. Jaundice is treated at levels that are much lower than those at which brain damage is a concern. Treatment can prevent the harmful effects of jaundice. Putting your baby in sunlight is not recommended as a safe way of treating jaundice. Exposing your baby to sunlight might help lower the bilirubin level, but this will only work if the baby is completely undressed. This cannot be done safely inside your home because your baby will get cold, and newborns should never be put in direct sunlight outside because they might get sunburned.

Q: When does jaundice go away?

A: In breastfed babies, jaundice often lasts for more than 2 to 3 weeks. In formula-fed babies, most jaundice goes away by 2 weeks. If your baby is jaundiced for more than 3 weeks, see your baby's doctor. Also available at www.aap.org/family/jaundicefaq.htm

Tested through the American Academy of Pediatrics Quality Improvement Innovation Network.

The recommendations in this publication do not indicate an exclusive course of treatment or serve as a standard of medical care. Variations, taking into account individual circumstances, may be appropriate. Original document included as part of Safe & Healthy Beginnings: A Resource Toolkit for Hospitals and Physicians' Offices. Copyright © 2009 American Academy of Pediatrics. Updated 6/2008. All Rights Reserved. The American Academy of Pediatrics does not review or endorse any modifications made to this document and in no event shall the AAP be liable for any such changes.



Petsch Respiratory Services

Call Us – Relax – Breathe Easier

104 S. Belair Road #8

Martinez GA 30907

PHONE 706-863-6252 FAX 706-863-2337

www.petschrespiratory.com



BiliBed® Phototherapy Unit

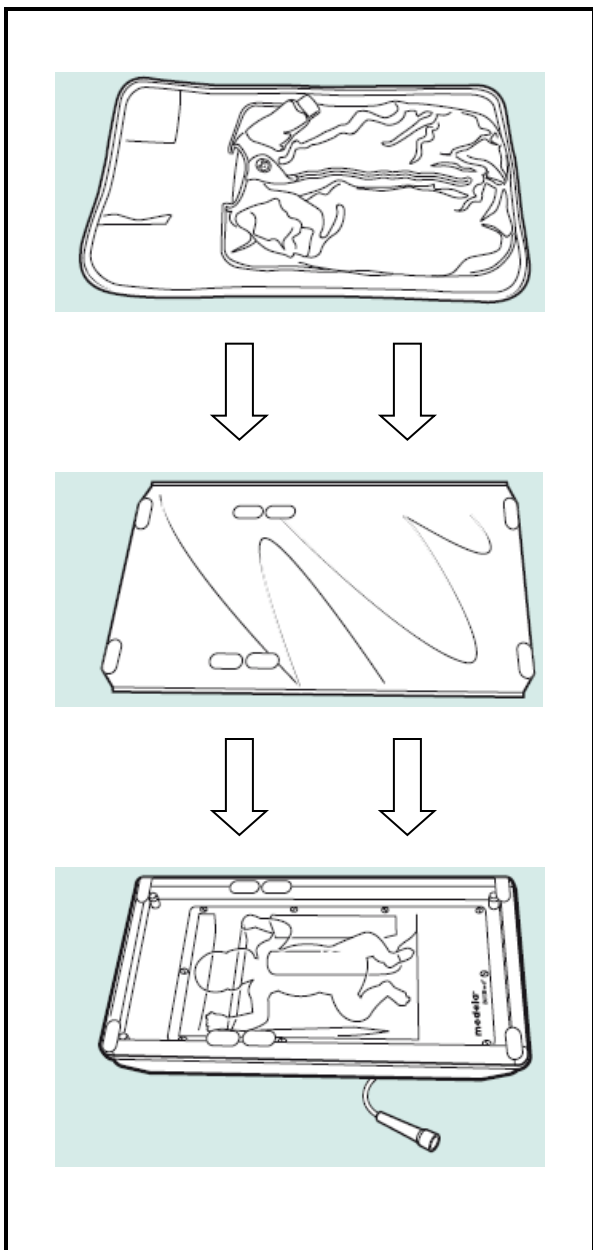

1
Attach the Bilicombi blanket to the baby support. See baby diagram on the bed for proper positioning



2
Unzip the Bilicombi blanket



3
Always lay the baby on his/her back in the Bilicombi blanket unless the physician tells you otherwise. See doctor for best sleeping positions for baby



4
Put the arms of the baby into the sleeves of the Bilicombi blanket



5
Zip / Fasten Velcro on the Bilicombi blanket. Close the Velcro fastener under the baby's chin



Petsch Respiratory Services

Call Us – Relax – Breathe Easier

104 S. Belair Road #8

Martinez GA 30907

PHONE 706-863-6252 FAX 706-863-2337

www.petschrespiratory.com

Baby's Phototherapy Log

Time	Minutes of Phototherapy	Minutes of time Breastfeeding (total)	Can you hear swallowing	Axillary Temperature	# of wet diapers (~6 in 24 hrs)	# of stools & color (~2-5 in 24 hrs)	Amount of formula given
8am-8:59	40 Mins.	15 Mins.	Yes / no	98.6 F	1	1 yellow, seedy	none
8am-8:59	Mins.	Mins.	Yes / no				
9am-9:59	Mins.	Mins.	Yes / no				
10am-10:59	Mins.	Mins.	Yes / no				
11am-11:59	Mins.	Mins.	Yes / no				
12pm-12:59	Mins.	Mins.	Yes / no				
1pm-1:59	Mins.	Mins.	Yes / no				
2pm-2:59	Mins.	Mins.	Yes / no				
3pm-3:59	Mins.	Mins.	Yes / no				
4pm-4:59	Mins.	Mins.	Yes / no				
5pm-5:59	Mins.	Mins.	Yes / no				
6pm-6:59	Mins.	Mins.	Yes / no				
7pm-7:59	Mins.	Mins.	Yes / no				
8pm-8:59	Mins.	Mins.	Yes / no				
9pm-9:59	Mins.	Mins.	Yes / no				
10pm-10:59	Mins.	Mins.	Yes / no				
11pm-11:59	Mins.	Mins.	Yes / no				
12am-12:59	Mins.	Mins.	Yes / no				
1am-1:59	Mins.	Mins.	Yes / no				
2am-2:59	Mins.	Mins.	Yes / no				
3am-3:59	Mins.	Mins.	Yes / no				
4am-4:59	Mins.	Mins.	Yes / no				
5am-5:59	Mins.	Mins.	Yes / no				
6am-6:59	Mins.	Mins.	Yes / no				
7am-7:59	Mins.	Mins.	Yes / no				



Petsch Respiratory Services

Call Us – Relax – Breathe Easier

104 S. Belair Road #8

Martinez GA 30907

PHONE 706-863-6252 FAX 706-863-2337

www.petschrespiratory.com

Baby's Phototherapy Log

Time	Minutes of Phototherapy	Minutes of time Breastfeeding (total)	Can you hear swallowing	Axillary Temperature	# of wet diapers (~6 in 24 hrs)	# of stools & color (~2-5 in 24 hrs)	Amount of formula given
8am-8:59	40 Mins.	15 Mins.	Yes / no	98.6 F	1	1 yellow, seedy	none
8am-8:59	Mins.	Mins.	Yes / no				
9am-9:59	Mins.	Mins.	Yes / no				
10am-10:59	Mins.	Mins.	Yes / no				
11am-11:59	Mins.	Mins.	Yes / no				
12pm-12:59	Mins.	Mins.	Yes / no				
1pm-1:59	Mins.	Mins.	Yes / no				
2pm-2:59	Mins.	Mins.	Yes / no				
3pm-3:59	Mins.	Mins.	Yes / no				
4pm-4:59	Mins.	Mins.	Yes / no				
5pm-5:59	Mins.	Mins.	Yes / no				
6pm-6:59	Mins.	Mins.	Yes / no				
7pm-7:59	Mins.	Mins.	Yes / no				
8pm-8:59	Mins.	Mins.	Yes / no				
9pm-9:59	Mins.	Mins.	Yes / no				
10pm-10:59	Mins.	Mins.	Yes / no				
11pm-11:59	Mins.	Mins.	Yes / no				
12am-12:59	Mins.	Mins.	Yes / no				
1am-1:59	Mins.	Mins.	Yes / no				
2am-2:59	Mins.	Mins.	Yes / no				
3am-3:59	Mins.	Mins.	Yes / no				
4am-4:59	Mins.	Mins.	Yes / no				
5am-5:59	Mins.	Mins.	Yes / no				
6am-6:59	Mins.	Mins.	Yes / no				
7am-7:59	Mins.	Mins.	Yes / no				



Petsch Respiratory Services

Call Us – Relax – Breathe Easier

104 S. Belair Road #8

Martinez GA 30907

PHONE 706-863-6252 FAX 706-863-2337

www.petschrespiratory.com

Baby's Phototherapy Log

Time	Minutes of Phototherapy	Minutes of time Breastfeeding (total)	Can you hear swallowing	Axillary Temperature	# of wet diapers (~6 in 24 hrs)	# of stools & color (~2-5 in 24 hrs)	Amount of formula given
8am-8:59	40 Mins.	15 Mins.	Yes / no	98.6 F	1	1 yellow, seedy	none
8am-8:59	Mins.	Mins.	Yes / no				
9am-9:59	Mins.	Mins.	Yes / no				
10am-10:59	Mins.	Mins.	Yes / no				
11am-11:59	Mins.	Mins.	Yes / no				
12pm-12:59	Mins.	Mins.	Yes / no				
1pm-1:59	Mins.	Mins.	Yes / no				
2pm-2:59	Mins.	Mins.	Yes / no				
3pm-3:59	Mins.	Mins.	Yes / no				
4pm-4:59	Mins.	Mins.	Yes / no				
5pm-5:59	Mins.	Mins.	Yes / no				
6pm-6:59	Mins.	Mins.	Yes / no				
7pm-7:59	Mins.	Mins.	Yes / no				
8pm-8:59	Mins.	Mins.	Yes / no				
9pm-9:59	Mins.	Mins.	Yes / no				
10pm-10:59	Mins.	Mins.	Yes / no				
11pm-11:59	Mins.	Mins.	Yes / no				
12am-12:59	Mins.	Mins.	Yes / no				
1am-1:59	Mins.	Mins.	Yes / no				
2am-2:59	Mins.	Mins.	Yes / no				
3am-3:59	Mins.	Mins.	Yes / no				
4am-4:59	Mins.	Mins.	Yes / no				
5am-5:59	Mins.	Mins.	Yes / no				
6am-6:59	Mins.	Mins.	Yes / no				
7am-7:59	Mins.	Mins.	Yes / no				