

Volume

2.6

AVR TECHNOLOGIES

AUTHORIZED DISTRIBUTOR NINGI SERVICES PTY (LTD)

M500 Industrial and mining motor/transformer protection

Technical & User Guide M500

INDUSTRIAL AND MINING CONTROLLERS

Technical & User Guide M500

All rights are reserved. Reproduction in whole or in part is prohibited without the prior written consent of the copyright owner.

The information presented in this document does not form part of any quotation or contract, is believed to be accurate and reliable and may be changed without notice. No liability will be accepted by the publisher for any consequence of its use. Publication thereof does not convey nor imply any license under patent- or other industrial or intellectual property rights

© AVR Technologies
Postnet Suite 269
Private Bag X7260 Witbank 1035
Phone 013 692 3501 • Fax 013 692 3392
EMAIL andre@tech4000.com
www.tech4000.com

Ningi Services pty (LTD)
Phone 082 556 7682
Fax 013 692 3392
Toll Free 0860 000 400
EMAIL info@ningi.com
<http://www.ningi.com>

Table of Contents

Introduction	2
Features	2
Installing the M500	4
M500 Protection offered in various states	5
Operating the M500	9
Protection offered during standby	10
Programming the M500	11
How to enter the programming menu	11
MENU MAP STANDARD	12
MENU MAP ADVANCED MODE 29	13
Description of the MENU functions	14
Data Logging	23
Communication	25
ASCII communication	25
Special Features	27
Technical Specifications	29
What is new in this volume	31

Introduction

The M500 protection and management controller is one of the most advanced protection controllers on the market today. By utilizing surface mount technology and a state of the art micro controller, functions can be performed previously not possible. High performance measuring techniques, and digital signal processing ensures very accurate measuring of all current and voltage inputs. A large non-volatile memory and real time clock guarantees tracking of all events with date and time stamp. RS485 Communication offers long distance operation, and access to the M500 internal memory. The compact size of the M500 make smaller panel design possible.



FIGURE 1

Features

- One unit for any size motor/transformer
- Star/Delta starting selectable
- Under/Over/Unbalance Voltage protection
- Phase loss, phase rotation detection
- Under/Over/Unbalance Current protection
- Earth fault protection
- Pre start warning
- Start up protection
- Auto start, auto stop, auto restart functions

- Infra red remote start, stop
- Infra red remote parameter adjustments
- Real time clock
- Data logging with date and time stamp on all events
- RS485/RS232 communication
- Three 10A 240Vac single pole normally open contacts
- Two 10A 240Vac single pole change over contacts
- Any combination of functions could be used
- Over voltage/ under voltage/ phase loss/ phase rotation/ earth fault and overload protection is offered even when in standby

Installing the M500

Clip the M500 to the DIN rail and connect as shown in figure 2.

The required control voltage to operate the M500 is 115Vac for the 115Vac model and 240Vac for the 240Vac model. The INHIBIT and STOP inputs must be normally closed to COMMON. The remainder of the inputs and outputs are dependent on customer requirements and must be wired accordingly.

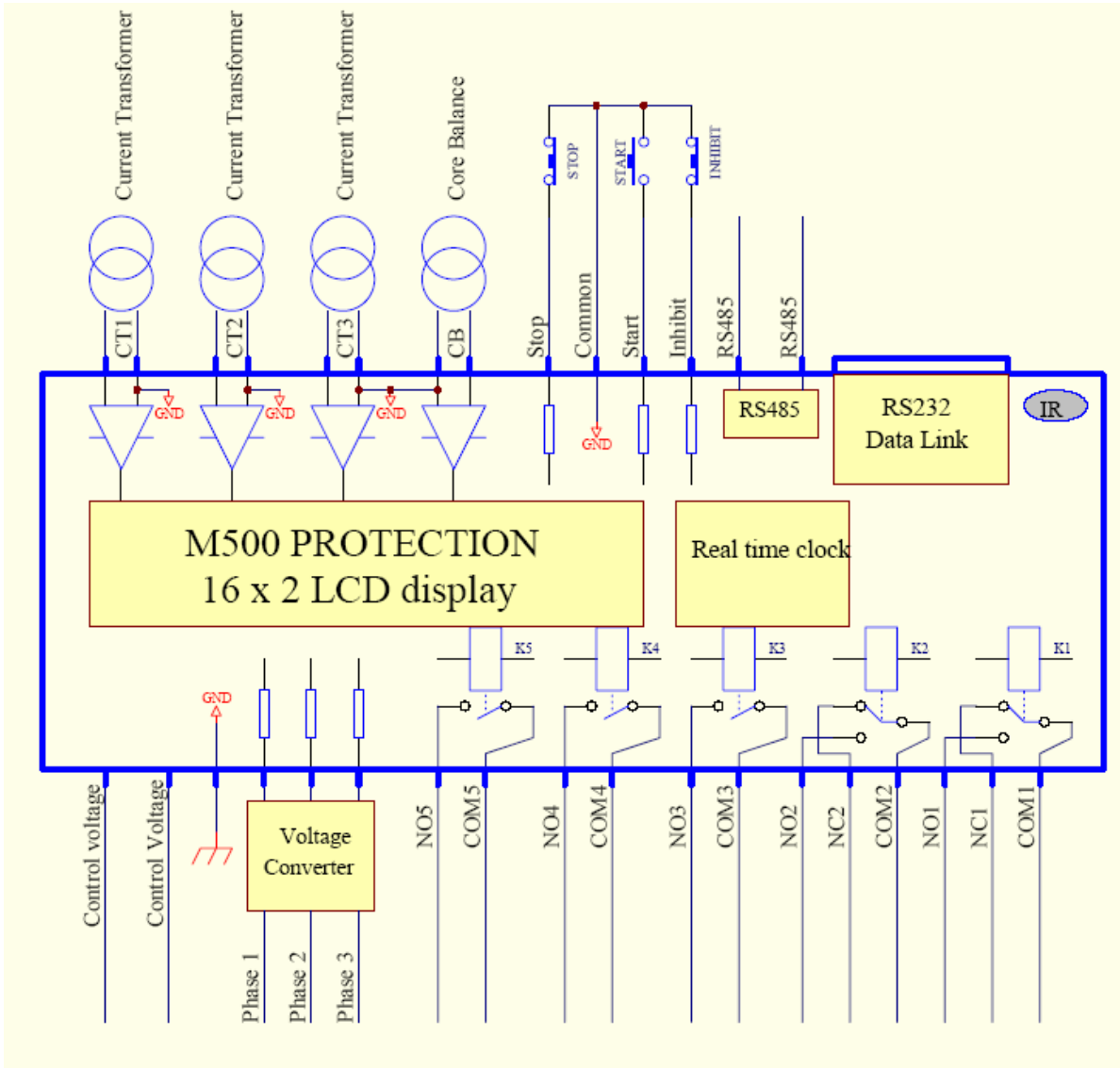

Figure 2

M500 Protection offered in various states

Protection is only available if it is selected in the MENU

Protection offered when in STANDBY or Pre Start

- Phase loss protection
- Phase rotation protection
- Time graded Earth Fault protection with Earth Fault @ Start as instantaneous trip
- Time graded Under Voltage protection
- Time graded Over Voltage protection
- Definite time or IDMT Overload protection
- Instantaneous Over Current protection

Protection offered on Start up

- I^2T protection
- Start up x I protection
- Short circuit x I protection
- Time graded Earth Fault protection
- Over Current protection

Protection offered when RUN (Running)

- Phase Loss protection
- Time graded Earth Fault protection with Earth Fault @ Start as instantaneous trip
- Time graded Under Voltage protection
- Time graded Over Voltage protection
- Time graded Voltage unbalance protection

- Time graded Under Current protection
- Definite time or inverse definite minimum time Over Load protection (IDMT)
- Time graded Current Unbalance protection
- Instantaneous Over Current protection

Installation considerations

Special care must be taken when installing the M500. Although the M500 is easy to operate and to install it is a highly sophisticated protection unit. The M500 incorporates many functions in one unit and the external connections are as vital as the internal operation.

CONTROL VOLTAGE

The total power consumption is less than 2VA. The M500 incorporates filters to cut off noise and harmonics. Surge protection is employed to protect the M500 against a surge on the control voltage.

PHASE INPUTS

The M500 **must** be connected to the phases via the voltage converter supplied. The voltage converter ensures correct voltage measurement on the phases but more important offers current limiting and reduced input voltage to a safe level. At 1200Vac phase voltage the voltage converter will limit the current to 2.5ma.

RELAY CONNECTIONS

All the relays are rated 10A at 240Vac. Wiring used must be capable of withstanding the current and voltage intended to be switched by the relays. Refer to the installation diagram for specifications.

CURRENT TRANSFORMERS

Special care must be taken with the installation of the current transformers. To conform to the IEC specification and to allow multiple times full load current to be measured the current inputs has an impedance of 0.1 ohm. It is very important that the current transformers are connected to the designated connectors. The current transformers are internally connected to earth but must also be connected one side to earth on the CT. For maximum accuracy, minimum 2.5VA current transformers must be used.

CORE BALANCE

Special care must be taken with the core balance transformer. This is a very sensitive input and is susceptible to noise and harmonics. Special material is used for the core in the core balance (M5CB1). Active low pass filters are implemented in the M500 to cut off harmonics and noise. Use the screened cable supplied with the core balance transformer. The screened cable consists of two wires and a screen. The screen of the screened cable must be connected to the panel (earth) at the core balance side. The screen must not be connected at the other side. If possible avoid using the same cable guides as the high current cables.

STOP

This input operates in a normally closed manner. The operating voltage on the STOP button is less than 12vDc. The M500 uses high voltage input tolerant circuitry, which can tolerate high voltage spikes on the input for short periods. The M500 also facilitates a damping circuit and digital filtering to ensure accurate operation.

START

This input operates in a normally open manner. The operating voltage on the START button is less than 12Vdc. The M500 uses high voltage input tolerant circuitry, which can tolerate high voltage spikes on the input for short periods. The M500 also facilitates a damping circuit and digital filtering to ensure accurate operation. If the SAFE START option is enabled in the programming menu the M500 requires the input to be closed and opened before M500 will start.

INHIBIT

This input serves as a lock on the M500. The M500 uses high voltage input tolerant circuitry, which can tolerate high voltage spikes on the input for short periods. The M500 will be disabled from any operation if

this input is open. This input may be used in conjunction with a lockable switch or with a PLC output. No starting is possible when this input is open.

COMMUNICATION RS485

The RS485 communication terminals are for operation via RS485 over long distances. As the distance and conditions may vary, specifications must be followed as specified by the design engineer. Twisted pair cable should be used but special care must be taken when long distances are required for communication. The RS485 specification allows for thirty-two devices on the same network. The two RS485 connections at each end must be terminated with 120 ohm resistors (available as part no. M5T1).

COMMUNICATION RS232

The RS232 communication is performed with the RS232 optically isolated cable (part no. M5RS1). The M5RS1 cable offers 5300 Volt isolation between the M500 and the personal computer. The cable configuration is DB9 female to RJ45.

Operating the M500

Upon power up the M500 will display the initial welcome message, version number and serial number. The LCD will display the status of the M500. The messages are displayed in easy to understand messages and will indicate the status on the M500. Following are some messages, which could be displayed after power up.

DISPLAY

STANDBY
2002/10/14 10:45

LOCKED
2002/10/14 10:45

STOP
248V 249V 247V

PHASE LOSS LINE
248V 0V 251V

PHASE ROTATION
248V 251V 249V

AUTO START IN
5 Sec

OVER VOLTAGE
480V 485V 482V

UNDER VOLTAGE
108V 251V 249V

RELEASE TO START

DESCRIPTION

System OK and ready to start

Inhibit input open. No starting Possible

Stop input open. No starting possible

Phase Loss. The voltage of the 3 phases is displayed and the corresponding relay is activated. No starting possible.

Phase sequence is reversed. The voltages of the phases are displayed and the corresponding relay is activated. No starting possible.

The auto start timer is set and the M500 will start when the seconds has timed out.

The voltage measured is higher than the over voltage limit and the corresponding relay is activated. No starting possible.

The voltage measured is lower than the under voltage limit and the corresponding relay is activated. No starting possible.

Safe start is enabled and the Start button is pressed. Release the START button to start

Protection offered during standby

While the M500 is in standby the following protection is available. For detailed operation see Description of the MENU functions

*T*ime graded Under Voltage protection

If the measured voltage is lower than the programmed under voltage level the display will indicate the condition and the corresponding relay will be activated while this condition is true. Note that if auxiliary relay 1 is linked to this function it operates in failsafe mode. I.e. Relay 1 is energized when there is no trip and de-energized when there is a trip. The display and relay will clear when the condition is cleared

*T*ime graded Over Voltage protection

If the measured voltage is higher than the programmed over voltage level the display will indicate the condition and the corresponding relay will be activated while this condition is true. Note that if auxiliary relay 1 is linked to this function it operates in failsafe mode. I.e. Relay 1 is energized when there is no trip and de-energized when there is a trip. The display and relay will clear when the condition is cleared

*P*hase loss protection

If the phase loss protection is enabled and there is a phase loss condition the corresponding relay will activate and the display will display the voltages on the three phases. Note that if auxiliary relay 1 is linked to this function it operates in failsafe mode. I.e. Relay 1 is energized when there is no trip and de-energized when there is a trip. The display and relay will clear when the condition is cleared

*P*hase rotation detection

If the phase rotation detection is enabled and the phase sequence is wrong the corresponding relay will activate and the display will indicate the condition. Note that if auxiliary relay 1 is linked to this function it operates in failsafe mode. I.e. Relay 1 is energized when there is no trip and de-energized when there is a trip. The display and relay will clear when the condition is cleared

*D*efinite time/ IDMT Overload Protection

If the Overload Current time is set to "OFF" IDMT is active. The relay will activate when the time exceed the IDMT or the definite time. The event will be logged and the fault must be cleared manually or via the communications network.

If the STOP button is pressed the volts of the three phases are displayed on the LCD.

If Auto start is selected in the menu the M500 will count down the seconds before the M500 will auto start. This function will only operate if all the selected protection functions are in order.

Programming the M500

Programming is performed with the infrared remote control or via the communications network. The easy to use handheld remote control can adjust all parameters, retrieve data from the data logger, start or stop the motor and adjust the time on the real time clock.

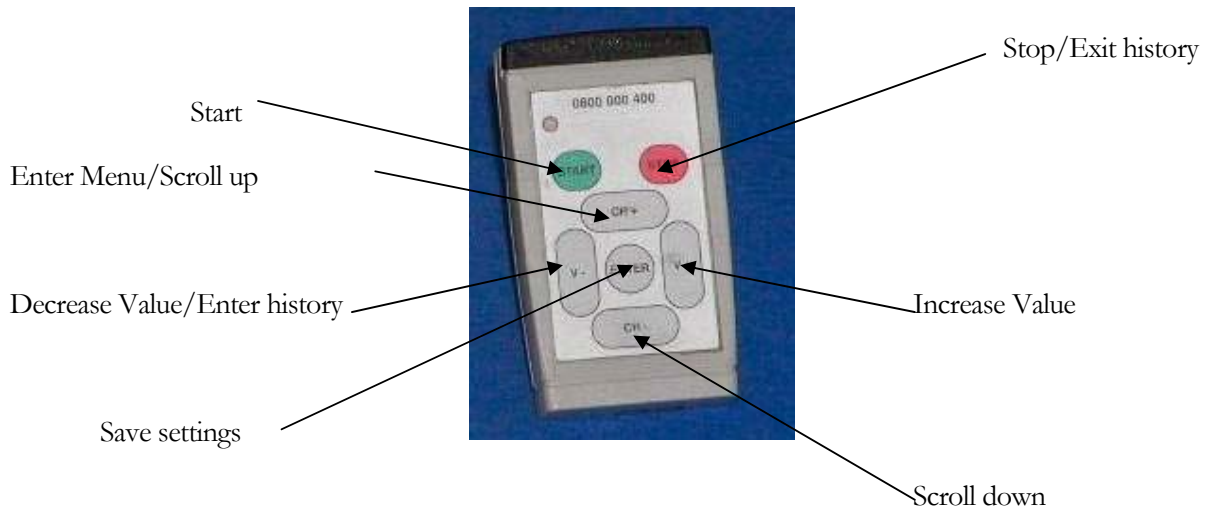

How to enter the programming menu

To enter the programming menu point the infrared remote control towards the M500 and press the CH+ button. The first menu option is MODE. To scroll up through the menu press CH+ and to scroll down through the menu press CH-. To increase the value press V+ and to decrease the value press V-. To exit and save press ENTER. To save the changes press ENTER again within 10 seconds. The menu can only be accessed when the motor is not running.

STANDBY
2002/10/14 12:34





PRESS CH+

MENU

MODE
40

MENU MAP

Only the following settings can be performed and critical settings are not accessible. This menu allows an operator to adjust non-critical settings.



NAME	MIN	DEFAULT	MAX	UNIT
MODE	OFF	40	255	
Pre Start	OFF	5	240	Seconds
Auto Start	OFF	OFF	240	Seconds
Auto Stop	OFF	OFF	240	Minutes
Low Restart 1	OFF	15	240	Minutes
Low Restart 2	OFF	60	240	Minutes

MENU MAP ADVANCED MODE 29

When MODE is set to 29 all the settings are accessible for adjustment. Only qualified persons must perform these settings.

	NAME	MIN	DEFAULT	MAX	UNIT
	MODE	OFF	40	255	
	Pre Start	OFF	5	240	Seconds
	Auto Start	OFF	OFF	240	Seconds
	Auto Stop	OFF	OFF	240	Minutes
	Low Restart 1	OFF	15	240	Minutes
	Low Restart 2	OFF	60	240	Minutes
	Phase Loss	OFF	ON	ON	
	Phase Rotation	OFF	ON	ON	
	Motor Start Up	OFF	10	240	Seconds
	I2T	OFF	1000	2500	Units
	Startup X I	OFF	6	20	Times
	Short Circuit x I	OFF	6	20	Times
	E Fault @ Start	OFF	500	500	ma
	E Fault @ Start	OFF	2	20	Seconds
	E Fault	OFF	100	500	ma
	E Fault	OFF	OFF	20	Seconds
	VT Ratio	OFF	Off	20	KV: 110V
	Under Voltage	OFF	OFF	700	Volt
	Over Voltage	OFF	OFF	700	Volt
	Volt Trip Delay	OFF	10	240	Seconds
	Volt Unbalance	OFF	20	90	%
	Volt Unbalance	OFF	10	240	Seconds
	CT Quantity	OFF	3	3	CT's
	CT Ratio	OFF	200	2000	:1
	Under Current	OFF	OFF	1900	Amp
	Under Current	OFF	10	240	Seconds
	Overload Current	OFF	OFF	2500	Amp
	Overload Current	OFF	0	240	Seconds
	Current Unbalance	OFF	OFF	90	%
	Current Unbalance	OFF	10	100	Seconds
	Safe Start	OFF	ON	ON	
	Cold Starts	OFF	6	20	Starts
	Run to Hot Time	OFF	30	180	Min
	Cooling Time	OFF	10	240	Min
	Star/Delta	OFF	OFF	20	Seconds
	Over Current	OFF	OFF	2500	Amp
	Pre Start Relay	OFF	OFF	4	Relay
	Under Voltage Relay	OFF	OFF	4	Relay
	U/Current Relay	OFF	OFF	4	Relay
	Phase Loss Relay	OFF	OFF	4	Relay
	Rotation Relay	OFF	OFF	4	Relay
	E Fault Relay	OFF	OFF	4	Relay
	O/Current Relay	OFF	OFF	4	Relay
	Over Volt Relay	OFF	OFF	4	Relay
	RS485	OFF	ON	ON	
	Baud Rate	OFF	9600	38400	bps
	ADDRESS	OFF	OFF	247	Address

Description of the MENU functions

MODE is used to enter specialized functions on the M500. Mode could be set between OFF (0) and 255. The default for MODE is 40. With MODE 40 only the basic menu functions are accessible. MODE 29 will expand the menu to the advanced settings. MODE 45 will reload all the default values. The other MODE values are reserved for future functions. See [special features](#) for other MODE functions.

PRE START. The range for pre start is OFF to 240 seconds. The default is 5 seconds. If OFF is selected there will be no pre start warning. Any other value will sound the internal buzzer for the selected number of seconds. If pre-start is assigned to an auxiliary relay that relay will be activated while pre-start is active.

AUTO START. The range for auto start is OFF to 240 seconds. The default is OFF. The M500 will start once the selected number of seconds has lapsed after power up.

AUTO STOP. The range for auto off is OFF to 240 minutes. The default is OFF. The M500 will stop once the selected number of minutes has lapsed.

LOW RESTART 1. The range for low restart 1 is OFF to 240 minutes. The default is 15 minutes. The M500 will restart after an under current trip once the selected number of minutes have passed.

LOW RESTART 2. The range for low restart 2 is OFF to 240 minutes. The default is 60 minutes. The M500 will restart after an under current trip the second time once the selected number of minutes have passed. Should the M500 detect normal current during the start up time period, LOW RESTART 1 will be the next start up time should an under current occur.

PHASE LOSS. The range is OFF and ON. The default is ON. If the setting is ON phase loss protection is activated.

PHASE ROTATION. The range is OFF and ON. The default is ON. If the setting is ON phase rotation detection is activated.

MOTOR START-UP. The range is OFF to 240 seconds. The default is 10 seconds. This setting will allow for the motor or transformer to start up and reach normal operating conditions. Settings that are used in this period is I²T, START-UP X I, SHORT CIRCUIT X I, EARTH FAULT @ START. These settings are normally higher than the normal operating conditions.

I²T. The range is OFF to 2500. The default is 1000. This function offers start up protection and comes into action when Start-up x I is exceeded. The value is derived by the equation (multiples of OverloadCurrent² * time). Should this value exceed the set value the M500 will trip. If this setting is OFF the M500 will trip immediately when Start Up x I is exceeded.

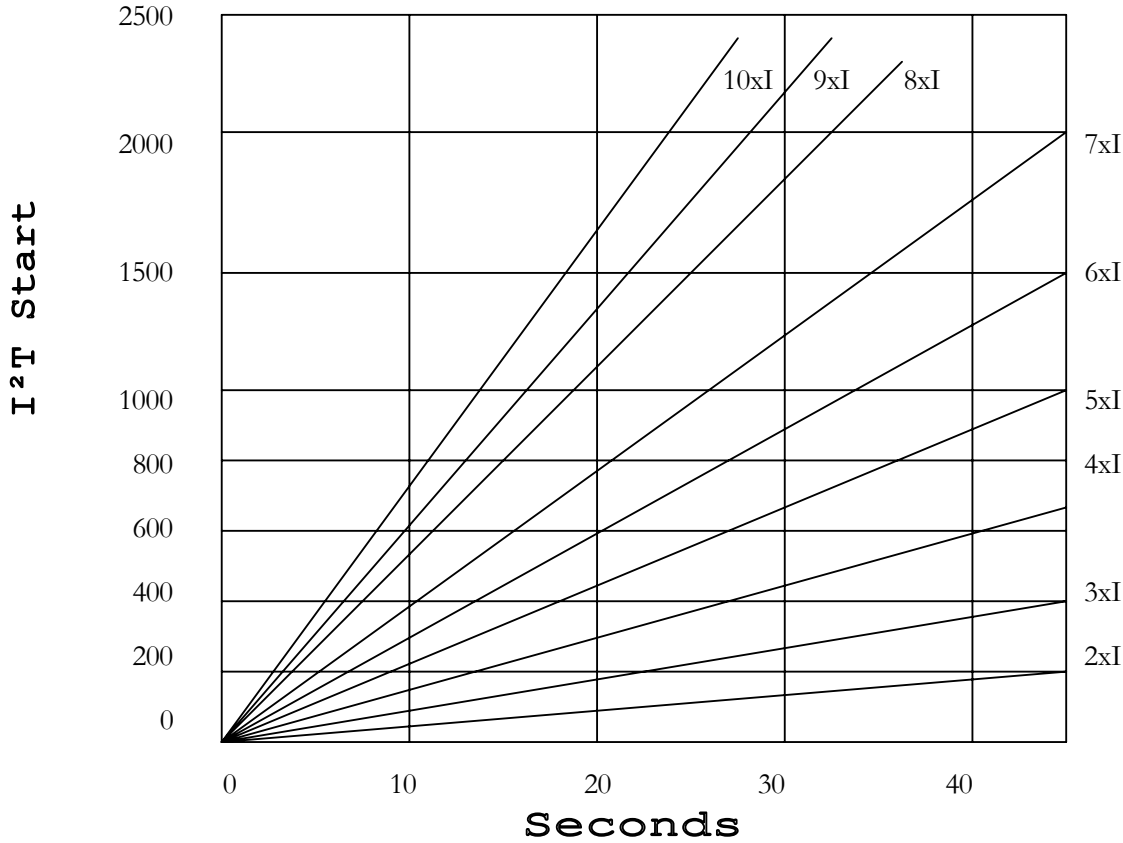

Figure 3 Setting and tripping curve for I²T

START-UP x I. The range is OFF to 20. The default is 6 times Overload Current. During the start up time the current may not exceed the set level. If the current level exceeds the set level and the I²T is not set the M500 will trip. Example Overload current is set at 100A. Start Up x I is set at 6. The maximum current allowed at start up is 100 x 6 = 600A.

SHORT CIRCUIT x I. The range is OFF to 20. This setting is the multiples of the Overload Current. The default is 6. The current may not exceed the set value for the start up time. If the current level exceeds the set level and the I²T is not set the M500 will trip. Example Overload current is set at 100A. Short circuit

x I is set at 6. The maximum current allowed at start up is $100 \times 6 = 600\text{A}$. This setting could be the same as the Start Up x I setting for direct on line motors.

E FAULT @ START. The range is OFF to 500ma. The default is 500ma. This is the maximum the earth fault may be during standby, the start up time or during the run period.

E FAULT @ START. The range is OFF to 20 seconds. This is the time the earth fault level at start may exceed the set value.

EARTH FAULT. The range is OFF to 500ma. The default is 100ma. This is the maximum the earth fault may be during normal operation for the set time delay. The M500 will trip instantaneous if the earth fault exceeds the level set at EFAULT @ START or if the level exceeds the earth fault setting and the time has lapsed in earth fault trip time.

EARTH FAULT. The range is OFF to 20 seconds. The default is 2 seconds. This is the time the earth fault level may exceed the set value. The trip is instantaneous when the level exceeds the EFAULT @ START level.

UNDER VOLTAGE. the range is OFF to 700 (RMS phase to neutral). The default is off. This setting will determine what the under voltage threshold is. If the setting is OFF there is no under voltage protection. Please note that the M500 measures RMS voltage from phase to neutral.

OVER VOLTAGE. the range is OFF to 700 (RMS phase to neutral). The default is off. This setting will determine what the over voltage threshold is. There is no over voltage protection if the setting is set to OFF. Please note that the M500 measures RMS voltage from phase to neutral.

VOLT TRIP DELAY. The range is OFF to 240 seconds. The default is 10 seconds. This is the time delay before the M500 will trip in an under/over voltage situation.

VOLT UNBALANCE. The range is OFF to 90%. The default is 20%. This value is derived from the voltage on the three phases. Voltage unbalance could cause heat in motors and should the three phases be unbalanced the M500 will trip should the time delay lapse. The unbalance value is derived from:

$$V_{\text{average}} = (V1 + V2 + V3) / 3$$

$$V1_{\text{unbalance}} = ((V1 - V_{\text{average}}) / V_{\text{average}}) * 100$$

$$V2_{\text{unbalance}} = ((V2 - V_{\text{average}}) / V_{\text{average}}) * 100$$

$$V3_{\text{unbalance}} = ((V3 - V_{\text{average}}) / V_{\text{average}}) * 100$$

VOLT UNBALANCE. The range is OFF to 240 seconds. The default is 10 seconds. Should the voltage unbalance exceed the set value and the time lapsed as set in this setting, the M500 will trip.

CT QUANTITY. The range is OFF to 3. The default is three. This setting will determine how many phases will be monitored for current. Should current unbalance be required select all three current transformers.

CT RATIO. The range is 10:1 to 2000:1. The default is 200:1. This setting must match the CT ratio used. The CT 's must be of the same ratio. The VA rating should not be less than 2.5VA.

UNDER CURRENT. the range is off to 1900 Amps. The default is off. This setting will determine the under current trip level. The measurement range is 0 to 110% of CT Ratio.

UNDER CURRENT. the range is off to 240 seconds. The default is 10 seconds. This is the time delay that an under current situation is allowed.

OVERLOAD CURRENT. The range is off to 2500 Amps. The default is off. This setting must be set at approximately 15% higher than the **full load current**. If the time delay is set to OFF the inverse definite-minimum time IDMT curve will determine the trip time. If this setting is set to any other value the M500 will trip immediately in an over current situation after the set seconds has passed. The trip time for IDMT is derived as $IDMT = 3/(\log M)$, where M is the multiples of **full load current**. The measurement range is 0 to 110% of CT Ratio.

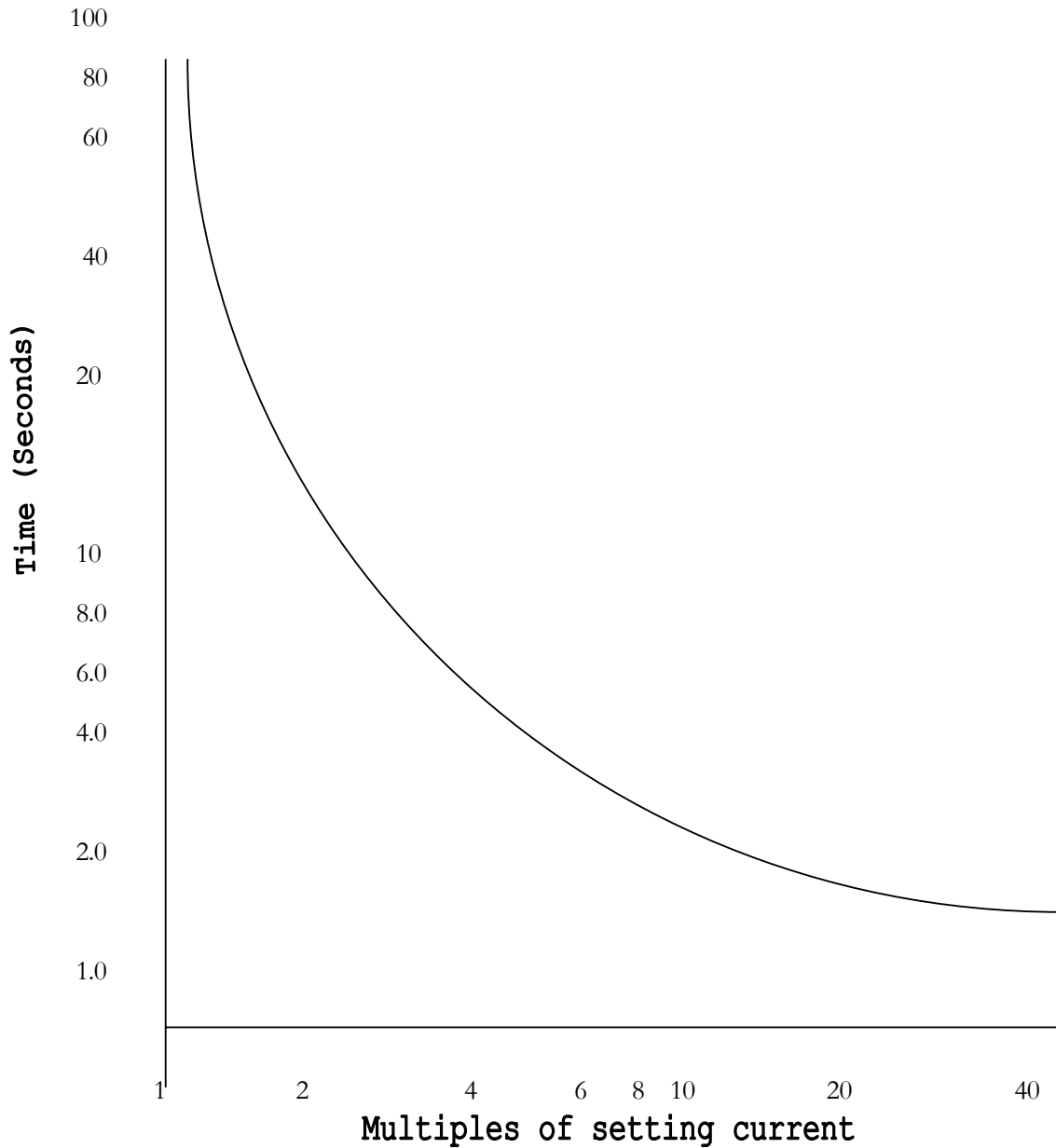

Figure 4 Characteristic curve Inverse definite-minimum time.

OVERLOAD CURRENT. The range is off to 240 seconds. The default is Off (IDMT). This is the time delay that an over current is allowed. If this setting is set to OFF inverse definite minimum time is active.

CURRENT UNBALANCE. The range is off to 90%. The default is OFF. The reason that unbalanced phase currents require disconnection of the load is that any unbalance in the current results in a negative phase sequence component which produces a rotating field in the opposite direction to the rotating field produced by the applied system voltage. This counter-rotating field will cause induced currents in the rotor of almost twice normal system frequency, resulting in overheating and possible damage. This result is derived from the negative phase sequence component in a three-phase system. All three phases must be measured to have this function active. If the current unbalance exceeds the set limit and time delay the M500 will trip. The current unbalance is derived from the formula:

$$I_{\text{average}} = (I1 + I2 + I3) / 3$$

$$I1_{\text{unbalance}} = ((I1 - I_{\text{average}}) / I_{\text{average}}) * 100$$

$$I2_{\text{unbalance}} = ((I2 - I_{\text{average}}) / I_{\text{average}}) * 100$$

$$I3_{\text{unbalance}} = ((I3 - I_{\text{average}}) / I_{\text{average}}) * 100$$

CURRENT UNBALANCE. The range is off to 100 seconds. The default is 10 seconds. This is the time unbalance is allowed.

SAFE START. When set to ON the M500 will start when the Start button is released.

Cold Starts. The range for this setting is OFF to 20. This is the number of cold starts allowed. The number of cold starts allowed will vary according to motor size and application. The default is 6. Each time the motor is started x minutes is added to the thermal image. X is derived from:

$$X = \text{Run to Hot time} / \text{Cold Starts} \quad \text{example:} \quad X = 30 / 6$$

$$X = 5$$

Each time the motor is started 5 minutes will be added to the thermal image contained in the non-volatile RAM. If the thermal image exceeds “**Run To Hot Time**” the M500 will not allow more starts.

Run Time to Hot. The range for this setting is OFF to 180. The default is 30 min. This is the time the motor is considered hot when running at full load. For each multiple of full load the time will decrease accordingly.

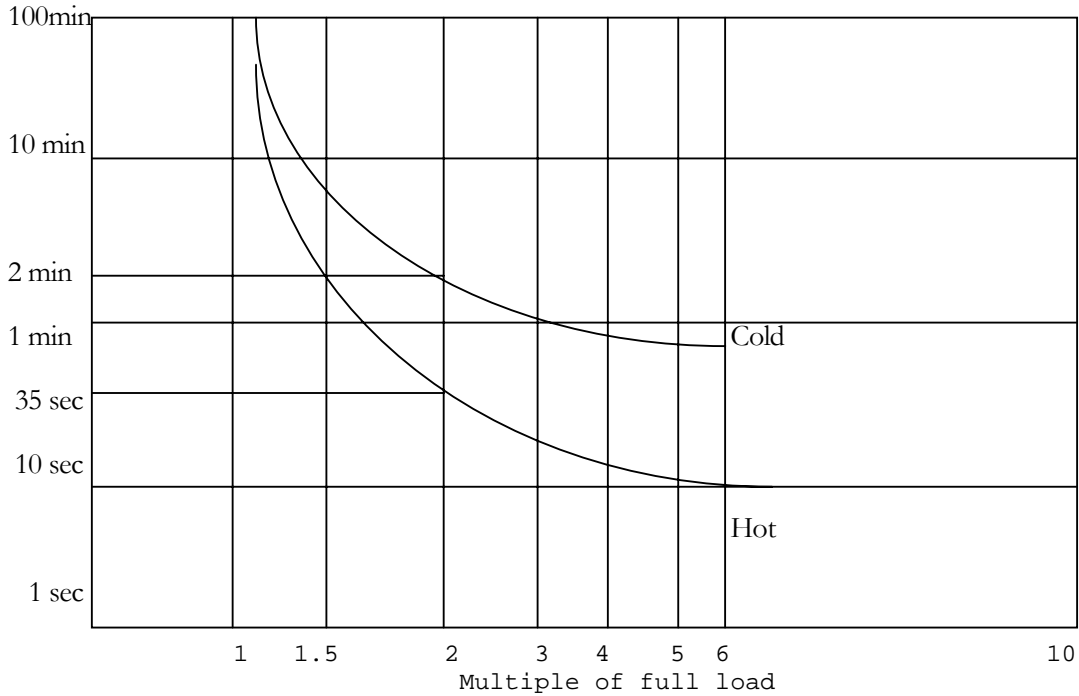

Figure 5 Thermal relay time/current characteristics

Cooling Time. The range is OFF to 180 Minutes. The default is 10 min. This setting is the length of time the M500 will not allow a restart after the hot starts have exceeded the set value. This time will allow the motor to cool.

Star/Delta. The range for this setting is OFF to 20 seconds. If this setting is set to OFF only Relay 5 will operate. This setting should be used for direct on line operation. Should star/delta starting be required the setting must be between 1 and 20 seconds. On start up relay 5 and 4 will energize for star starting. After the seconds has timed out relay 4 will de-energize and relay 3 will energize, switching over to delta. If Star/delta is selected auxiliary relay 3 & 4 are not available for other purposes.

OVER CURRENT. The range for this setting is OFF to 2500 Amp. The default is OFF. This is the absolute maximum current. Should the current exceed this level the M500 will trip instantaneous. The measurement range is 0 to 110% of the CT Ratio.

INSTANTANEOUS OVER CURRENT PROTECTION

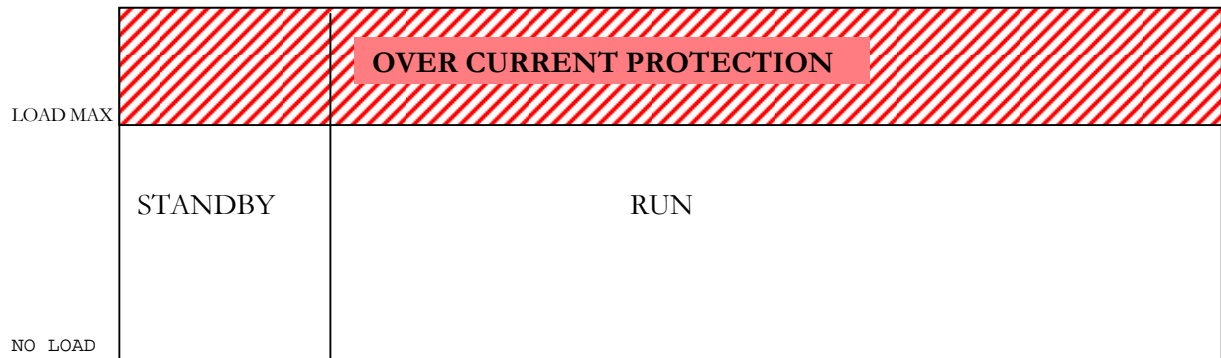

Pre start Relay. The range is OFF to 4. The corresponding relay will be activated with the pre start warning time.

Voltage Relay. The range is OFF to 4. If the M500 trips on under/over voltage or voltage unbalance the corresponding relay will activate.

Under Current Relay. The range is OFF to 4. If the M500 trips on under current the corresponding relay will activate.

Phase Relay. The range is OFF to 4. When the M500 trips or detects phase loss or phase rotation the corresponding relay will activate.

Efault Relay. The range is OFF to 4. When the M500 trips on earth fault the corresponding relay will activate.

Over Current Relay. The range is OFF to 4. When the M500 trips on over current or current unbalance the corresponding relay will activate.

RS485. The setting range is OFF and ON. The default is ON. When RS232 communication is required RS485 should be set to OFF. For RS485 communication this setting should be ON.

Baud Rate. The range is OFF to 38400 bps. The default is 9600 bps. Make sure that the setting matches the network baud rate. The M500 uses 1 Start, 8 data and 1 Stop bit with no parity. No handshaking is used.

Address. The range is OFF to 247. The default is OFF. This setting will determine the M500 address on the network. No two M500 addresses may be the same on the same network. If the ADDRESS is set to OFF normal ASCII communication is enabled. ADDRESS 1 to 247 will enable the MODBUS RTU protocol.

Data Logging

Two Hour meters will log the running hours of the M500. The first hour meter is a non-reset hour meter and the second hour meter could be cleared. The second hour meter could be used to indicate service intervals.

All events are logged to the non-volatile memory. The non-volatile memory will store the last 896 events.

The following events will be logged.

- Manual Start
- Infra Red Start
- Auto Start
- Manual Stop
- Infra Red Stop
- Auto Stop
- Phase Loss
- Under Voltage
- Over Voltage
- Volt Unbalance
- Earth Fault Trip
- Under Current
- Overload Current
- Current Unbalance
- Over Current

All events are logged in the following sequence.

Date, Time, Event, Phase1 Volts, Phase2 Volts, Phase3 Volts, Control Voltage, Phase1 Amps, Phase2 Amps, Phase3 Amps, Earth Fault mA.

Each event will have this format.

2002-11-18 18:12:01 Over Current 415V 418V 411V 228V 17.4A 18.2A 17.9A 12ma

The data can be retrieved via the:

Infrared remote. Only the date, time and events are available with the infrared remote control.

Communication network. All information is available with this method.

Download to the I-Link. All information is available with this method.

Communication

The M500 offers communications via RS232 or RS485. The communication protocol is MODBUS RTU compatible or normal ASCII mode.

MODBUS RTU protocol is available to enable compatibility to standard network packages. ASCII mode is available to enable easy connection and communication via RS232. Any standard terminal program could be used like hyper terminal, found in windows at programs, accessories, communications, hyper terminal.

RS485 is used in half duplex mode. See connection diagram (figure 2) for the connection terminals.

RS232 is connected with a RJ45 to DB9 cable optically isolated at 5.3kV as part no. M5RS1.

ASCII communication

Connect the M500 with the optically isolated RS232 cable to an available COM port. Use the hyper terminal or equivalent program to communicate with the M500. Set the communication for 9600bps, 8 bits, no parity, 1 Stop bit (9600,8,n,1).

When the communication is performed via RS232 the ASCII mode will be selected automatically by the M500. In ASCII mode no CRC is performed to allow for an easy communication protocol. RS232 or RS485 may be used at any one time.

RS232 communication allows the user to access the internal memory and to operate the M500.

ASCII mode transmission

Standard RS232 1 Start, 8 Data bits, 1 Stop bit is used for RS232 communication.

Begin End

FUNCTION	DATA 1	DATA 2
----------	--------	--------

ASCII mode reception.

Begin End

FUNCTION	DATA 1	DATA n + 1
----------	--------	------------

FUNCTION is a value between 0 and 255. The function will determine what type of action will be performed.

FUNCTIONS:

01 Read the time from the real time clock on the M500

Example: To read the time from the real time clock on the M500.

SEND ASCII

0 1

RECEIVE

0 1 2 0 0 2 1 0 1 4 1 2 4 5

2002/10/14 12:45

Function - year - month - day - hour - minutes

PRELIMINARY

Special Features

There are special functions available on the M500.

When the M500 is on standby and the STOP button is pressed the voltages of the three phases are displayed on the LCD.

When the M500 is running the motor/transformer and the START button is pressed, the amps and volts of the three phases are displayed on the LCD.

When MODE is set to 49 and the M500 is running the amps and volts will be continuously displayed on the LCD.

When MODE is set to 50 and the M500 is running the amps and volts will not be displayed on the LCD when the START button is pressed.

When MODE is set to 41 the second hour meter will be cleared.

MODE 80 will clear the thermal image (commissioning only)

The M500 will measure current from 0 to 120% of the CT Ratio

PRELIMINARY

Relays

Each relay performs certain functions in the operation sequence of the M500. Up to five relays are available for operation.

RELAY 1

This relay has single pole change over contacts rated 10A 240Vac/440Vac. Switching power 2500V. The insulation coil to contacts is 5000V. Fully sealed construction. This relay operates in fail to safe mode. When the M500 is powered this relay will be energized. If any trip is assigned to this relay this relay will be de energized when the trip occurs. This relay could also serve as a mains fail/power down relay.

RELAY 2

This relay has single pole change over contacts rated 10A 240Vac/440Vac. Switching power 2500V. The insulation coil to contacts is 5000V. Fully sealed construction. This relay will operate (energize) when a trip occur which is linked to this relay.

RELAY 3

This relay is single pole normally open contact rated at 10A 240Vac/440Vac. Switching power 2500V. The insulation coil to contacts is 5000V. Fully sealed construction. This relay will operate (energize) when a trip occur which is linked to this relay. If STAR/DELTA is selected on the menu this relay will operate the DELTA contactor. When STAR/DELTA is selected this relay will not be available for other functions.

RELAY 4

This relay is single pole normally open contact rated at 10A 240Vac/440Vac. Switching power 2500V. The insulation coil to contacts is 5000V. Fully sealed construction. This relay will operate (energize) when a trip occur which is linked to this relay. If STAR/DELTA is selected on the menu this relay will operate the STAR contactor. When STAR/DELTA is selected this relay will not be available for other functions.

RELAY 5

This relay is single pole normally open contact rated at 10A 240Vac/440Vac. Switching power 2500V. The insulation coil to contacts is 5000V. Fully sealed construction. This relay is the main relay to operate the contactor. This relay serves no other function.

Technical Specifications

INPUT

Control Voltage	115/230 Vac (Specify on order)
Phase voltage input	0 ~ 1200 Vac (Phase to Phase RMS) 0 ~ 700 Vac (Phase to neutral)
Current detection	0.1 ~ 2000 Amp
CT Ratio	10:1 ~ 2000:1 (Min 2.5VA)
CT Quantity	1,2 or 3
Earth Fault detection	30 ~ 500 ma (Use core balance part no. M5CB1)

CONTROL

Stop	normally closed
Inhibit	normally closed
Start	normally open

OUTPUT

Relay 1 contacts CO 2500V-Insulation 5000V-Fully sealed	10A 240Vac/440Vac-Switching	power
Relay 2 contacts CO 2500V-Insulation 5000V-Fully sealed	10A 240Vac/440Vac-Switching	power
Relay 3 contacts NO 2500V-Insulation 5000V-Fully sealed	10A 240Vac/440Vac-Switching	power
Relay 4 contacts NO 2500V-Insulation 5000V-Fully sealed	10A 240Vac/440Vac-Switching	power
Relay 5 contacts NO 2500V-Insulation 5000V-Fully sealed	10A 240Vac/440Vac-Switching	power
Piezo buzzer pre start warning	81dB	

COMMUNICATION

Infra Red receiver	5m 38kHz carrier
--------------------	------------------

RS 485 transceiver	max 115 kbps 1200m
RS 232 transceiver optically isolated	(Use RS232 optically isolated cable part no. M5RS1)

PHYSICAL

Size in mm	105Wx58Hx81L
Weight	0.5kg
Mount	DIN rail

ACCURACY

	Specification	Actual
Voltage measurement	< 10%	3%
Current measurement	< 10%	5%
Voltage Unbalance measurement	< 15%	12%
Current Unbalance measurement	< 15%	13.7%
Time graded trips and timers	< 7.5%	5%
Earth Fault measurement	< 5%	2%
Earth Fault instantaneous trip	< 150ms	112ms
Earth Fault trip timers	< 5%	3%
Power supply interruption test	> 500ms	2 Sec

What is new in this volume

All the changes made are only to the manual and not to the M500 motor protection device. This colour is used for the amendments.

All reference to FLC (Full Load Current) is changed to Overload Current.

Add VT Ratio to manual

Add Over Voltage relay to manual

Change Phase Relay to Phase Loss Relay

Add Rotation Relay to manual

M500 current measurement