

RCEL Series Actuators



FEATURES

- Standard enclosure IP-67, NEMA 4, 4x
- Squirrel cage, totally enclosed motor
- Standardized and color-coded wiring
- Manual override hand/auto declutch lever, automatic reset when motor is energized
- Handwheel designed for safe, efficient operation
- Mounting standardized to ISO-5211; removable drive bushing can be machined to match valve stem
- Wormgear drive for longer life and low maximum noise level of 50dB
- Indicator top mounted for continuous visual indication of valve position
- 20 watt internal heater to minimize condensation due to temperature and humidity changes
- Cam actuated, end of travel limit switches are easily adjusted to de-energize actuator for precise valve position
- Torque switch is cam actuated and factory set to provide over torque protection for valves, available in size RCEL-15 thru RCEL-250
- Mechanical limit stops designed to prevent over-travel of quarter turn applications
- Valve backdrive is prevented by a rolled steel wormgear and aluminum bronze wormwheel
- CSA C/US Approval on 120 VAC only

Remote Control RCEL Series Electric Actuators are engineered to provide efficient, high performance automation of quarter turn valves. The RCEL Series has improved reliability incorporating all the best features.

OPTIONS

- | | |
|---------|--|
| EXP | Explosion & Water Proof Enclosure Class I C & D / Class II E, F & G Exd IIB T4 IP67 |
| DCM | 24 VDC Motor (RCEL-6 thru RCEL-28) |
| ACM | 24 VAC Motor (RCEL-6 thru RCEL-28) |
| ALS | Auxiliary Limit Switches 2 SPDT switches (6 aux switches max) |
| EXT | Extended Travel Angle 120° to 360° (RCEL-6 thru RCEL-100) |
| LCU | Local Control Unit (NEMA-4) local/remote selector switch open/stop/close selector switch |
| LCU KEY | Local Control Unit (NEMA-4) w/key with key lock |
| PIU | 1K Ohm Feedback Potentiometer |
| CPT | Current Position Feedback Transmitter 4-20mA DC output |
| DCT | VDC Position Feedback Transmitter 1-5VDC, 0-5VDC and 0-10VDC |
| PCU | Proportional Control Unit 4-20mA, 1-5VDC or 0-10VDC input |
| IMS | Integral Motor Starter includes reversing contactors and step down transformer |
| CLC | Repeat Cycle Timer for cycle length control |
| ATS | Auxiliary Torque Switches 2 SPDT switches (RCEL-15 thru RCEL-250) |



STANDARD SPECIFICATIONS

Enclosure	Watertight IP67, Nema 4, 4x
Ambient Temp.	From -20° to +158° Fahrenheit 300° Fahrenheit for 1 hour
Power Supply	120/220VAC 1-Phase 380/440VAC 3-Phase
Control Power	110/220VAC 1-Phase, 50/50Hz
Duty Cycle	See Performance Chart
Torque Switches	(2) Open/Close (RCEL-15 thru RCEL-250)
Limit Switches	(2) Open/Close, 250 VAC 16A Rating
Stall Protection	Internal Thermal Protection Open 300°F/Close 207°F
Travel Angle	90° ± 5°
Indicator	Continuous Position Indicator
Manual Override	HAND/AUTO Declutching Mechanism
Self Locking	Provided by means of Worm Gearing
Mechanical Stops	External Adjustable Screws
Space Heater	20Watt (24/120/220 VAC and 24 VDC) Anti-Condensation
Conduit Entries	Two 3/4" NPT.
Lubrication	Grease Moly (EP) Type
Materials	Steel, Aluminum Alloy, Aluminum Bronze
Surface Treatment	Anodizing
External Coating	Dry Powder, Epoxy-Polyester

PERFORMANCE

TYPE	Max Output Torque Inch Pounds	Operating Time 60/50 hz 90°	Duty Cycle 30 min. T.P.	Rated Current Amps/Locked Rotor Amps				Weight Lbs.
				1-Phase		3-Phase		
				120vac	220vac	380vac	440vac	
RCEL-6	521	14/17	100%	0.66/1.36	0.29/0.83	0.12/0.33	0.14/0.37	24
RCEL-9	781	14/17	100%	1.07/2.10	0.49/0.87	0.14/0.37	0.17/0.41	24
RCEL-15	1302	17/20	80%	1.45/2.14	0.71/1.12	0.30/0.61	0.30/0.65	27
RCEL-19	1649	17/20	80%	1.60/2.97	0.90/1.52	0.33/0.77	0.34/0.83	29
RCEL-28	2430	20/24	100%	1.60/2.97	0.90/1.52	0.33/0.77	0.34/0.83	38
RCEL-38	3298	20/24	100%	1.95/3.75	1.26/1.85	0.36/0.80	0.37/0.87	40
RCEL-50	4340	20/24	80%	3.10/4.90	1.50/2.34	0.56/1.27	0.57/1.36	42
RCEL-60	5208	24/29	80%	3.10/4.90	1.50/2.34	0.56/1.27	0.57/1.36	49
RCEL-80	6944	24/29	70%	4.10/7.50	2.15/3.70	0.84/1.76	0.78/1.88	51
RCEL-100	8680	24/29	70%	4.10/7.50	2.15/3.70	0.84/1.76	0.78/1.88	55
RCEL-150	13020	72/87	80%	3.10/4.90	1.50/2.34	0.56/1.27	0.57/1.36	150
RCEL-200	17360	72/87	70%	4.10/7.50	2.15/3.70	0.84/1.76	0.78/1.88	154
RCEL-250	21700	72/87	70%	4.10/7.50	2.15/3.70	0.84/1.76	0.78/1.88	154

DIMENSIONS

RCEL-6 thru RCEL-100

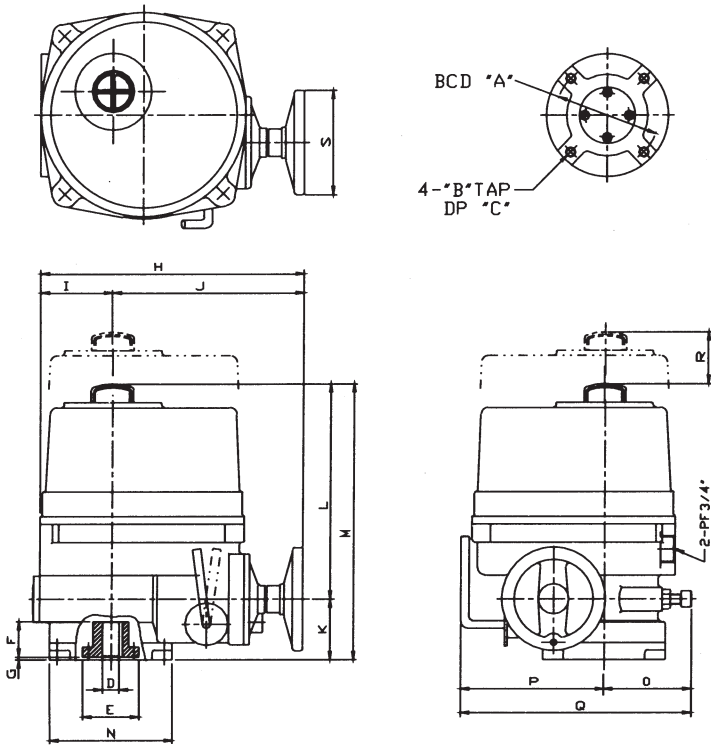

RCEL-150 thru RCEL-250

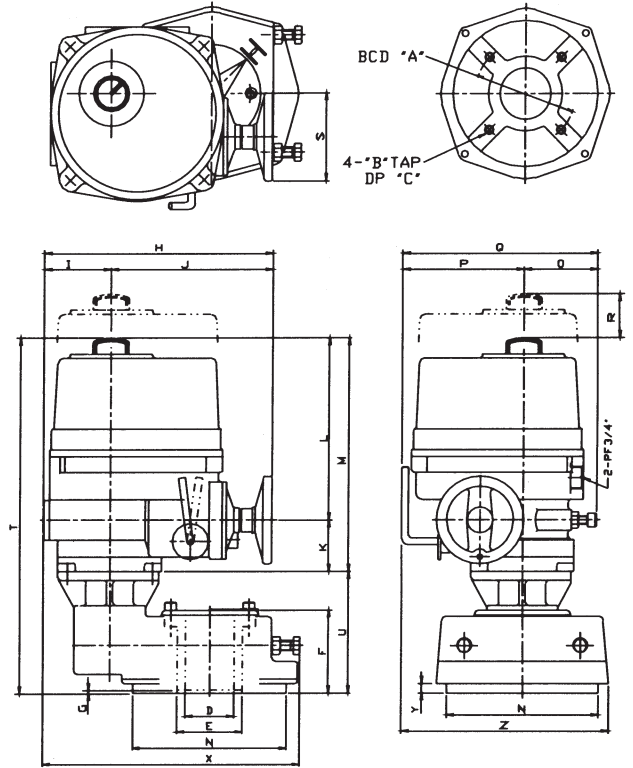

MODEL	RCEL-6	RCEL-9	RCEL-15	RCEL-19	RCEL-28	RCEL-38	RCEL-50	RCEL-60	RCEL-80	RCEL-100	RCEL-150	RCEL-200	RCEL-250
ISO 5211 FLANGE	F-07	F-07 / F-10	F-07 / F-10	F-07 / F-10	F-10 / F-12	F-10 / F-12	F-10 / F-12	F-12 / F-14	F-12 / F-14	F-12 / F-14	F-12 / F-14	F-12 / F-14	F-16
A	2.76	2.76 / 4.02	2.76 / 4.02	2.76 / 4.02	4.02 / 4.92	4.02 / 4.92	4.02 / 4.92	4.92 / 5.51	4.92 / 5.51	4.92 / 5.51	4.92 / 5.51	4.92 / 5.51	6.5
B	M8	M8 / M10	M8 / M10	M8 / M10	M10 / M12	M10 / M12	M10 / M12	M12 / M16	M12 / M16	M12 / M16	M12 / M16	M12 / M16	M20
Thread Pitch	1.25	1.25 / 1.5	1.25 / 1.5	1.25 / 1.5	1.5 / 1.75	1.5 / 1.75	1.5 / 1.75	1.75 / 2.0	1.75 / 2.0	1.75 / 2.0	1.75 / 2.0	1.75 / 2.0	2.5
C	.47	.59	.59	.59	.71	.71	.71	.87	.87	.87	.87	.87	1.18
D-MAX	0.87	0.87	0.87	0.87	1.26	1.26	1.26	1.65	1.65	1.65	1.65	1.65	2.95
E	2.17	2.24	2.24	2.24	2.95	2.95	2.95	3.35	3.35	3.35	3.35	3.35	3.94
F	1.69	1.69	1.69	1.69	2.05	2.05	2.05	2.32	2.32	2.32	2.32	2.32	3.87
G	.08	.08	.08	.08	.08	.08	.08	.08	.08	.08	.08	.08	.28
H	9.09	10.28	10.28	10.28	11.22	11.22	11.22	12.8	12.8	12.8	12.8	12.8	12.8
I	2.21	3.03	3.03	3.03	3.27	3.27	3.27	3.9	3.9	3.9	3.9	3.9	3.9
J	6.89	7.25	7.25	7.25	7.95	7.95	7.95	8.9	8.9	8.9	8.9	8.9	8.9
K	2.36	2.36	2.36	2.36	2.76	2.76	2.76	3.07	3.07	3.07	3.07	3.07	3.07
L	8.39	8.39	8.39	8.39	9.84	9.84	9.84	11.14	11.14	11.14	11.14	11.14	11.14
M	10.75	10.75	10.75	10.75	12.6	12.6	12.6	14.21	14.21	14.21	14.21	14.21	14.21
N	4.02	4.73	4.73	4.73	5.71	5.71	5.71	6.89	6.89	6.89	6.89	6.89	10.47
O	2.68	3.35	3.35	3.35	3.9	3.9	3.9	4.57	4.57	4.57	4.57	4.57	4.57
P	4.45	5.47	5.47	5.47	6.26	6.26	6.26	7.52	7.52	7.52	7.52	7.52	7.52
Q	7.13	8.82	8.82	8.82	10.16	10.16	10.16	12.09	12.09	12.09	12.09	12.09	12.09
R	4.25	4.25	4.25	4.25	5.12	5.12	5.12	7.01	7.01	7.01	7.01	7.01	7.01
S	4.02	4.92	4.92	4.92	4.92	4.92	4.92	6.69	6.69	6.69	6.69	6.69	6.69
T	NA	NA	NA	NA	NA	NA	NA	NA	NA	NA	NA	NA	21.89
U	NA	NA	NA	NA	NA	NA	NA	NA	NA	NA	NA	NA	7.68
X	NA	NA	NA	NA	NA	NA	NA	NA	NA	NA	NA	NA	15.28
Y	NA	NA	NA	NA	NA	NA	NA	NA	NA	NA	NA	NA	0.63
Z	NA	NA	NA	NA	NA	NA	NA	NA	NA	NA	NA	NA	12.52

"B" dimension is metric. All other dimensions are inches.

APPLICATION DATA

CUSTOMER

Company _____
Street _____
City _____
Zip _____
Attention _____

DETAIL

Job _____
Item _____
Tag _____

VALVE INFORMATION

Mfg _____ Type _____ Size _____ Fig No _____
Valve rotation to close (as viewed from top) _____ Clockwise _____ Counter-clockwise _____
Max. required torque (with safety) _____ Inch Pounds.

ACTUATOR REQUIREMENTS

Application _____ Open/Close Service _____ Modulating Service _____ Other _____
Ambient Temperature _____ F to _____ F
Supply Voltage _____ volt AC _____ Hz, 1- phase or 3-phase _____ volt DC
Control Voltage _____ volt AC _____ Hz, 1- phase or _____ volt DC. (When IMS is required)

OPTIONAL ITEMS (AS REQUIRED)

Position Feedback Transmitter _____	(4-20A, 0-5vdc, 1-5vdc or 0-10vdc)
Proportional Control Unit _____	(4-20mA, 1-5vdc or 0-10vdc)
Aux. Limit Switch (6-max) _____	Integral Motor Starter _____
Local Control Unit _____	Delay On/Off Relay _____
Cycle Timer Control _____	Other _____