

*Herman*

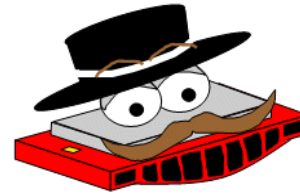

*Henrietta*



*Herman*



*Henrietta*

# HARMONICA HANDBOOK

# HARMONICA HANDBOOK



*Hubert*

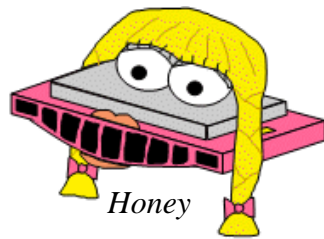

*Honey*



*Hans*



*Hubert*

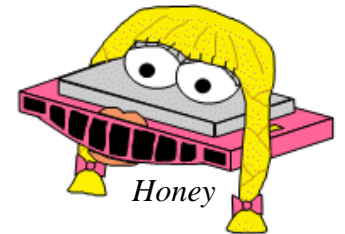

*Honey*

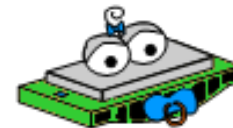

*Hans*

## **Websites**

<http://www.harmonica.com> (J.P. Allen)  
<http://www.harmonica4kids.com> (David Gage)  
<http://www.harmonicaacademy.com>  
<http://www.harmonicasuperstart.com>  
<http://us.playhohner.com/media>  
<http://www.bluesharp.com>

## **Websites**

<http://www.harmonica.com> (J.P. Allen)  
<http://www.harmonica4kids.com> (David Gage)  
<http://www.harmonicaacademy.com>  
<http://www.harmonicasuperstart.com>  
<http://us.playhohner.com/media>  
<http://www.bluesharp.com>



**HARMONICA**  
Start with a Strategy  
website



**HARMONICA**  
Start with a Strategy  
website

<http://www.makejoyfulsound.org/harmonica.html>



## How to Hold the Harmonica:

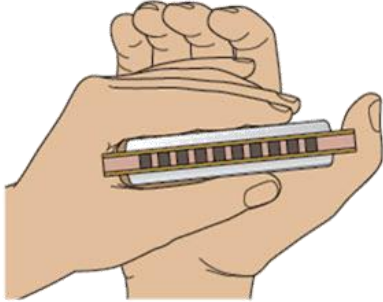

To start, hold your harmonica between your thumb and first two fingers on both hands. The side of the harmonica that has the numbers above the holes should be on top.

## How to Play the Harmonica:

Unlike other wind instruments, you make sounds on the harmonica while breathing both in and out. DRAW means INHALE like you are drinking from a straw.

BLOW means BREATH out like you normally do (not a hard breath like blowing up a balloon!) (Think “ah” for draw and “hah” for blow.)

You should feel your stomach go in a bit on the blow and out a bit on the draw.



## How to Hold the Harmonica:

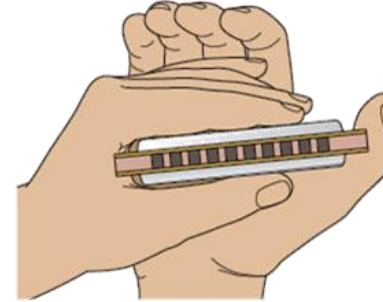

To start, hold your harmonica between your thumb and first two fingers on both hands. The side of the harmonica that has the numbers above the holes should be on top.

## How to Play the Harmonica:

Unlike other wind instruments, you make sounds on the harmonica while breathing both in and out. DRAW means INHALE like you are drinking from a straw.

BLOW means BREATH out like you normally do (not a hard breath like blowing up a balloon!) (Think “ah” for draw and “hah” for blow.)

You should feel your stomach go in a bit on the blow and out a bit on the draw.



**If you're feeling lightheaded,** whisper "It doesn't take much air" into your harmonica gently. Try "drawing" as you say this phrase too!



**If you're feeling lightheaded,** whisper "It doesn't take much air" into your harmonica gently. Try "drawing" as you say this phrase too!



### Good tone test:



Hold the harmonica with just your mouth—between your teeth. This gets your jaw, lips and tongue out of the way. Listen to your sound as you draw and blow. This is the kind of tone you want to get when you are playing your harmonica the correct way.

Here are some other ways to help your tone:

- ♪ Imagine your mouth is a really big cave
- ♪ Think about how a scuba diver breathes
- ♪ Blow gently like a cat slowly purring
- ♪ Shape your mouth as if you are yawning

### Good tone test:

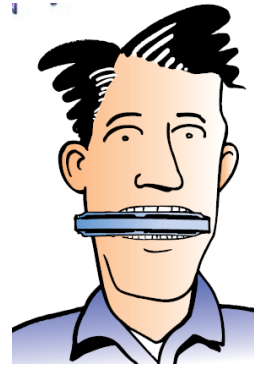

Hold the harmonica with just your mouth—between your teeth. This gets your jaw, lips and tongue out of the way. Listen to your sound as you draw and blow. This is the kind of tone you want to get when you are playing your harmonica the correct way.

Here are some other ways to help your tone:

- ♪ Imagine your mouth is a really big cave
- ♪ Think about how a scuba diver breathes
- ♪ Blow gently like a cat slowly purring
- ♪ Shape your mouth as if you are yawning

## Harmonica Tablature:

You'll find a number of ways the music for harmonica is notated. Here is the way it is written for THIS handbook:

- ♪ The number represents the hole on the harmonica.
- ♪ The number alone is played with a blow (*breathe out*).
- ♪ The circled number with a minus (-) sign is played with a draw (*breathe in*).

4 = BLOW on hole 4  
④ = DRAW on hole 4

## C Major Scale

4 ④ 5 ⑤ 6 ⑥ ⑦ 7  
*do re mi fa so la ti do*

Here are the note names of the harmonica holes.  
Blow 4 is *do*.

Hole	1	2	3	4	5	6	7	8	9	10
Blow	C	E	G	C	E	G	C	E	G	C
Draw	D	G	B	D	F	A	B	D	F	A

## Harmonica Tablature:

You'll find a number of ways the music for harmonica is notated. Here is the way it is written for THIS handbook:

- ♪ The number represents the hole on the harmonica.
- ♪ The number alone is played with a blow (*breathe out*).
- ♪ The circled number with a minus (-) sign is played with a draw (*breathe in*).

4 = BLOW on hole 4  
④ = DRAW on hole 4

## C Major Scale

4 ④ 5 ⑤ 6 ⑥ ⑦ 7  
*do re mi fa so la ti do*

Here are the note names of the harmonica holes.  
Blow 4 is *do*.

Hole	1	2	3	4	5	6	7	8	9	10
Blow	C	E	G	C	E	G	C	E	G	C
Draw	D	G	B	D	F	A	B	D	F	A

## The Blues

in 4 out in in 4 out in

out 5 in out in 4 out in

in in in in out out out out in 4 out in

## The Blues

in 4 out in in 4 out in

out 5 in out in 4 out in

in in in in out out out out in 4 out in

## Techniques & Sound Effects:

wah wah  
chugg  
a dood  
le  
tweet  
dirty dog doo wop  
ooo-eee

## Techniques & Sound Effects:

wah wah  
chugg  
a dood  
le  
tweet  
dirty dog doo wop  
ooo-eee

## PLAYING SINGLE NOTES

### - Partial Songs

#### Old Mac Donald Had A Farm

5 5 (-4) (-4) 4  
EE - I - EE - I - O

#### Fiddle-I-Fee

5 5 (-4) 4  
Fid-dle I Fee

#### Down By The Bay

5 5 (-4) 4  
Down by the bay.

#### Hokey Pokey

6 6 6 (-6) (-7) 7  
That's what it's all a-bout!

#### I Know an Old Lady

6 (-6) (-7) 7  
Perhaps she'll die



## PLAYING SINGLE NOTES

### - Partial Songs

#### Old Mac Donald Had A Farm

5 5 (-4) (-4) 4  
EE - I - EE - I - O

#### Fiddle-I-Fee

5 5 (-4) 4  
Fid-dle I Fee

#### Down By The Bay

5 5 (-4) 4  
Down by the bay.

#### Hokey Pokey

6 6 6 (-6) (-7) 7  
That's what it's all a-bout!

#### I Know an Old Lady

6 (-6) (-7) 7  
Perhaps she'll die



## PLAYING SINGLE NOTES

### - Partial Songs *p.2*

#### He's Got the Whole World in His Hands

6 6 5 6 6 (5) (4) 4  
He's got the whole world in his  
hands.



#### Ten in the Bed

6 5 4 6 5 4  
Roll over, roll over!

#### Camptown Races

5 (4) 5 (4) (4) 5 (4) 4  
Doo dah Doo dah / Oh, doo dah day

#### Today Is Monday

5 5 (4) (4) 4  
Come and eat it up

#### When I First Came to This Land

(6) (5) 4 (4) 4  
I did what I could

## PLAYING SINGLE NOTES

### - Partial Songs *p.2*

#### He's Got the Whole World in His Hands

6 6 5 6 6 (5) (4) 4  
He's got the whole world in his  
hands.



#### Ten in the Bed

6 5 4 6 5 4  
Roll over, roll over!

#### Camptown Races

5 (4) 5 (4) (4) 5 (4) 4  
Doo dah Doo dah / Oh, doo dah day

#### Today Is Monday

5 5 (4) (4) 4  
Come and eat it up

#### When I First Came to This Land

(6) (5) 4 (4) 4  
I did what I could



# PLAYING SINGLE NOTES

## - Complete Songs

### Hot Cross Buns - *Traditional*

5 (-4) 4  
Hot cross buns,

5 (-4) 4  
Hot cross buns,

4 4 4 4 (-4)(-4)(-4)(-4)

One a pen-ny, two a pen-ny,

5 (-4) 4  
Hot cross buns.



# PLAYING SINGLE NOTES

## - Complete Songs

### Hot Cross Buns - *Traditional*

5 (-4) 4  
Hot cross buns,

5 (-4) 4  
Hot cross buns,

4 4 4 4 (-4)(-4)(-4)(-4)

One a pen-ny, two a pen-ny,

5 (-4) 4  
Hot cross buns.



### Merrily We Roll Along - *Traditional*

5 (-4) 4 (-4) 5 5 5  
Mer-ri-ly we roll a-long,

(-4)(-4)(-4) 5 5 5  
Roll a-long, roll a-long.

5 (-4) 4 (-4) 5 5 5  
Mer-ri-ly we roll a-long

(-4) (-4) 5 (-4) 4  
O'er the deep blue sea.

### Merrily We Roll Along - *Traditional*

5 (-4) 4 (-4) 5 5 5  
Mer-ri-ly we roll a-long,

(-4)(-4)(-4) 5 5 5  
Roll a-long, roll a-long.

5 (-4) 4 (-4) 5 5 5  
Mer-ri-ly we roll a-long

(-4) (-4) 5 (-4) 4  
O'er the deep blue sea.

## Long-Legged Sailor

4 (-4) 5 5 5 5 5 5  
Did you ever, ever, ever  
(-4) 4 5 5 5 5  
In your long-legged life  
4 (-4) 5 5 5 5 5  
Meet a long-legged sailor  
(-4) 4 5 (-4)(-4) 4  
With a long-legged wife

4 (-4) 5 5 5 5 5 5  
No, I never, ever, ever  
(-4) 4 5 5 5 5  
In my long-legged life  
4 (-4) 5 5 5 5 5  
Met a long-legged sailor  
(-4) 4 5 (-4)(-4) 4  
With a long-legged wife

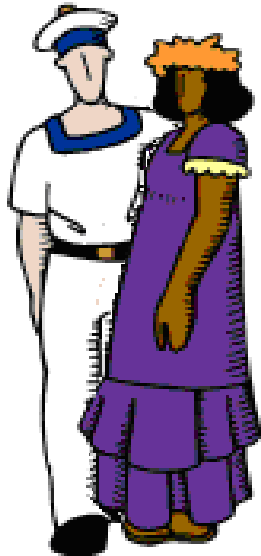

## Long-Legged Sailor

4 (-4) 5 5 5 5 5 5  
Did you ever, ever, ever  
(-4) 4 5 5 5 5  
In your long-legged life  
4 (-4) 5 5 5 5 5  
Meet a long-legged sailor  
(-4) 4 5 (-4)(-4) 4  
With a long-legged wife

4 (-4) 5 5 5 5 5 5  
No, I never, ever, ever  
(-4) 4 5 5 5 5  
In my long-legged life  
4 (-4) 5 5 5 5 5  
Met a long-legged sailor  
(-4) 4 5 (-4)(-4) 4  
With a long-legged wife

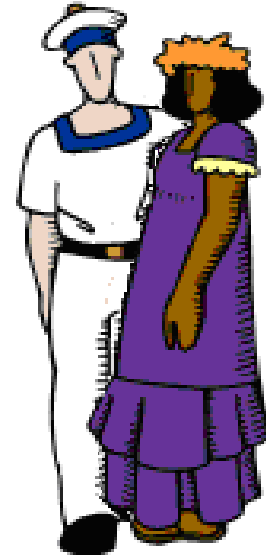

## Twinkle, Twinkle, Little Star – *Mozart Melody*

4 4 6 6 (6)(6) 6  
Twin-kle, twin-kle, lit-tle star,  
(5)(5) 5 5 (4) (4) 4  
How I won-der what you are  
6 6 (5) (5) 5 5 (4)  
Up a-bove the world so high  
6 6 (5) (5) 5 5 (4)  
Like a dia-mond in the sky.  
4 4 6 6 (6)(6) 6  
Twin-kle, twin-kle, lit-tle star,  
(5)(5) 5 5 (4) (4) 4  
How I won-der what you are.



## Twinkle, Twinkle, Little Star – *Mozart Melody*

4 4 6 6 (6)(6) 6  
Twin-kle, twin-kle, lit-tle star,  
(5)(5) 5 5 (4) (4) 4  
How I won-der what you are  
6 6 (5) (5) 5 5 (4)  
Up a-bove the world so high  
6 6 (5) (5) 5 5 (4)  
Like a dia-mond in the sky.  
4 4 6 6 (6)(6) 6  
Twin-kle, twin-kle, lit-tle star,  
(5)(5) 5 5 (4) (4) 4  
How I won-der what you are.



## When the Saints Go Marching In

– *African/American Spiritual*

4 5 (5) 6 4 5 (5) 6  
Oh, when the saints go marching in  
4 5 (5) 6 5 4 5 (4)  
Oh, when the saints go marching in  
5 5 (4) 4 4 5 6 6 6 (5)  
Oh, Lord, I want to be in that number  
5 (5) 6 5 4 (4) 4  
When the saints go marching in.

## When the Saints Go Marching In

– *African/American Spiritual*

4 5 (5) 6 4 5 (5) 6  
Oh, when the saints go marching in  
4 5 (5) 6 5 4 5 (4)  
Oh, when the saints go marching in  
5 5 (4) 4 4 5 6 6 6 (5)  
Oh, Lord, I want to be in that number  
5 (5) 6 5 4 (4) 4  
When the saints go marching in.

## Hush, Little Baby – *Lullaby*



- 3 5 5 5 (-5) 5 (-4) (-4) (-4)
1. Hush, little baby, don't say a word  
3 3 (-4) (-4) (-4) (-4) 5 (-4) 4 4  
Papa's gonna buy you a mocking bird.
- 3 5 5 (-5) 5 (-4) (-4)
2. If that mocking bird can't sing,  
3 3 (-4) (-4) (-4) (-4) 5 (-4) 4 4  
Papa's gonna buy you a diamond ring.
3. If that diamond ring turns to brass,  
Papa's gonna buy you a looking glass.
4. If that looking glass gets broke,  
Papa's gonna buy you Billy goat.
5. If that Billy goat won't pull,  
Papa's gonna buy you a cart and bull.
6. If that cart and bull turn over,  
Papa's gonna buy you a dog named Rover.
7. If that dog named Rover won't bark,  
Papa's gonna buy you a horse and cart.
8. If that horse and cart fall down,  
You'll be the sweetest little baby in town.

## Hush, Little Baby – *Lullaby*



- 3 5 5 5 (-5) 5 (-4) (-4) (-4)
1. Hush, little baby, don't say a word  
3 3 (-4) (-4) (-4) (-4) 5 (-4) 4 4  
Papa's gonna buy you a mocking bird.
- 3 5 5 (-5) 5 (-4) (-4)
2. If that mocking bird can't sing,  
3 3 (-4) (-4) (-4) (-4) 5 (-4) 4 4  
Papa's gonna buy you a diamond ring.
3. If that diamond ring turns to brass,  
Papa's gonna buy you a looking glass.
4. If that looking glass gets broke,  
Papa's gonna buy you Billy goat.
5. If that Billy goat won't pull,  
Papa's gonna buy you a cart and bull.
6. If that cart and bull turn over,  
Papa's gonna buy you a dog named Rover.
7. If that dog named Rover won't bark,  
Papa's gonna buy you a horse and cart.
8. If that horse and cart fall down,  
You'll be the sweetest little baby in town.

**Bow Wow Wow** — *American Game Song*

4 4 4  
Bow wow wow  
5 5 5 5  
Whose dog art thou?  
6 6 6 (-6) 6 5 4  
Lit-tle Tom-my Tucker's dog.  
5 (-4) 4  
Bow wow wow.



**Bow Wow Wow** — *American Game Song*

4 4 4  
Bow wow wow  
5 5 5 5  
Whose dog art thou?  
6 6 6 (-6) 6 5 4  
Lit-tle Tom-my Tucker's dog.  
5 (-4) 4  
Bow wow wow.



**Let Us Chase the Squirrel** - *Traditional*

4 4 (-4) (-4) 5 6  
Let us chase the squir-rel  
4 4 (-4) (-4) 5 5 (-4) (-4)  
Up the hick'ry, down the hick'ry  
4 4 (-4) (-4) 5 6 4 4 (-4) (-4) 4  
Let us chase the squir-rel up the hick'ry tree.

**Let Us Chase the Squirrel** - *Traditional*

4 4 (-4) (-4) 5 6  
Let us chase the squir-rel  
4 4 (-4) (-4) 5 5 (-4) (-4)  
Up the hick'ry, down the hick'ry  
4 4 (-4) (-4) 5 6 4 4 (-4) (-4) 4  
Let us chase the squir-rel up the hick'ry tree.

**Frog in the Meadow** - *Traditional*

5 5 5 (-4) 4 5 5 5 4  
Frog in the meadow, can't get him out,  
5 5 5 5 (-4) 4 5 5 5 4  
Take a lit-tle stick and stir him a-bout.

**Frog in the Meadow** - *Traditional*

5 5 5 (-4) 4 5 5 5 4  
Frog in the meadow, can't get him out,  
5 5 5 5 (-4) 4 5 5 5 4  
Take a lit-tle stick and stir him a-bout.

## Rocky Mountain

4 4 4 5 4 4 4 5  
Rocky Mountain, Rocky Mountain

4 4 5 6 6  
Rocky Mountain high

(-6) 6 5 4  
When you're on that

(-6) 6 5 4  
Rocky Mountain

5 5 (-4) (-4) 4  
Hang your head and cry.

4 5 6 (-6) 5 5 (-4) 4 (-4)  
Do, do, do, do Do remember me.

4 5 6 (-6)  
Do, do, do, do

5 5 (-4) (-4) 4  
Do remember me.



## Rocky Mountain

4 4 4 5 4 4 4 5  
Rocky Mountain, Rocky Mountain

4 4 5 6 6  
Rocky Mountain high

(-6) 6 5 4  
When you're on that

(-6) 6 5 4  
Rocky Mountain

5 5 (-4) (-4) 4  
Hang your head and cry.

4 5 6 (-6) 5 5 (-4) 4 (-4)  
Do, do, do, do Do remember me.

4 5 6 (-6)  
Do, do, do, do

5 5 (-4) (-4) 4  
Do remember me.

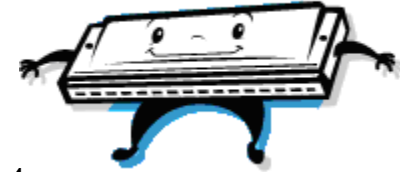

2. Rocky Mountain, Rocky Mountain  
Rocky Mountain low  
When you're in that sunny valley,  
Sing it soft and slow. (refrain)

3. Stormy ocean, stormy ocean,  
Stormy ocean wide  
When you're on that stormy ocean  
There's no place you can hide. (refrain)

2. Rocky Mountain, Rocky Mountain  
Rocky Mountain low  
When you're in that sunny valley,  
Sing it soft and slow. (refrain)

3. Stormy ocean, stormy ocean,  
Stormy ocean wide  
When you're on that stormy ocean  
There's no place you can hide. (refrain)

**Mary Had A Little Lamb** - *Traditional*

5 (-4) 4 (-4) 5 5 5  
Mar-y had a lit-tle lamb,  
(-4)(-4) (-4) 5 6 6  
Lit-tle lamb, lit-tle lamb.

5 (-4) 4 (-4) 5 5 5  
Mar-y had a lit-tle lamb  
5 (-4) (-4) 5 (-4) 4  
Its fleece was white as snow.



**Mary Had A Little Lamb** - *Traditional*

5 (-4) 4 (-4) 5 5 5  
Mar-y had a lit-tle lamb,  
(-4)(-4) (-4) 5 6 6  
Lit-tle lamb, lit-tle lamb.

5 (-4) 4 (-4) 5 5 5  
Mar-y had a lit-tle lamb  
5 (-4) (-4) 5 (-4) 4  
Its fleece was white as snow.



**Skip to My Lou** - *Traditional*

5 5 5 4 4 4 5 5 6  
Flies in the buttermilk, shoo, fly, shoo  
(-4) (-4)(-4) (-3)(-3)(-3) (-4) (-4) (-5)  
Flies in the buttermilk, shoo, fly, shoo

5 5 5 4 4 4 5 5 6  
Flies in the buttermilk, shoo, fly, shoo  
(-4) 5 (-5) 5 (-4) 4 4

Skip to my Lou my darling  
5 4 5 5 5 6

Lou, Lou, skip to my Lou  
(-4) (-3) (-4)(-4)(-4) (-5)

Lou, Lou, skip to my Lou  
5 4 5 5 5 6

Lou, Lou, skip to my Lou  
(-4) 5 (-5) 5 (-4) 4 4

Skip to my Lou my darling.

**Skip to My Lou** - *Traditional*

5 5 5 4 4 4 5 5 6  
Flies in the buttermilk, shoo, fly, shoo  
(-4) (-4)(-4) (-3)(-3)(-3) (-4) (-4) (-5)  
Flies in the buttermilk, shoo, fly, shoo

5 5 5 4 4 4 5 5 6  
Flies in the buttermilk, shoo, fly, shoo  
(-4) 5 (-5) 5 (-4) 4 4

Skip to my Lou my darling  
5 4 5 5 5 6

Lou, Lou, skip to my Lou  
(-4) (-3) (-4)(-4)(-4) (-5)

Lou, Lou, skip to my Lou  
5 4 5 5 5 6

Lou, Lou, skip to my Lou  
(-4) 5 (-5) 5 (-4) 4 4

Skip to my Lou my darling.

**Oh Susanna** — *Stephen Foster*

4 (-4) 5 6 6 (-6) 6 5  
 I — come from A-la-bama  
 4 (-4) 5 5 (-4) 4 (-4)  
 With my banjo on my knee  
 4 (-4) 5 6 6 (-6) 6 5  
 And I'm going to Lou'si-a-na  
 4 (-4) 5 5 (-4) (-4) 4  
 My — true love for to see.  
 4 (-4) 5 6 6 (-6) 6 5 4  
 It — rained all day the night I left  
 (-4) 5 5 (-4) 4 (-4)  
 The weather it was dry  
 4 (-4) 5 6 6 (-6) 6 5 4  
 The — sun so hot I froze to death  
 (-4) 5 5 (-4) (-4) 4  
 Susanna, don't you cry.



(-5) (-5) (-6) (-6)  
 Oh, Susanna!  
 (-6) 6 6 5 4 (-4)  
 Oh, don't you cry for me  
 4 (-4) 5 6 6 (-6) 6 5  
 For I come from A-la-bama  
 4 (-4) 5 5 (-4) (-4) 4  
 With my banjo on my knee

**Oh Susanna** — *Stephen Foster*

4 (-4) 5 6 6 (-6) 6 5  
 I — come from A-la-bama  
 4 (-4) 5 5 (-4) 4 (-4)  
 With my banjo on my knee  
 4 (-4) 5 6 6 (-6) 6 5  
 And I'm going to Lou'si-a-na  
 4 (-4) 5 5 (-4) (-4) 4  
 My — true love for to see.  
 4 (-4) 5 6 6 (-6) 6 5 4  
 It — rained all day the night I left  
 (-4) 5 5 (-4) 4 (-4)  
 The weather it was dry  
 4 (-4) 5 6 6 (-6) 6 5 4  
 The — sun so hot I froze to death  
 (-4) 5 5 (-4) (-4) 4  
 Susanna, don't you cry.



(-5) (-5) (-6) (-6)  
 Oh, Susanna!  
 (-6) 6 6 5 4 (-4)  
 Oh, don't you cry for me  
 4 (-4) 5 6 6 (-6) 6 5  
 For I come from A-la-bama  
 4 (-4) 5 5 (-4) (-4) 4  
 With my banjo on my knee



## Shoo, Fly

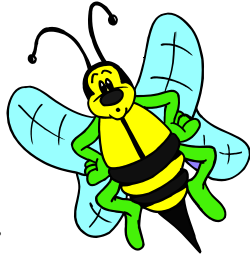

5 4 (-4) 5 (-5) (-4)  
Shoo, fly, don't bother me.  
(-4) (-3) 4 (-4) 5 4  
Shoo, fly, don't bother me.  
5 4 (-4) 5 (-5) (-4)  
Shoo, fly, don't bother me.  
(-4) 6 6 6 (-5) 5 (-4) 4  
For I belong to somebody.

3 5 5 5 5 5  
I feel, I feel, I feel,  
3 5 5 5 (-5) 5 (-4)  
I feel like the morning star.  
3 (-4) (-4) (-4) (-4) (-4) (-4) (-4)  
I feel, I feel, I feel, I feel,  
3 6 6 6 (-5) (-4) 4 6  
I feel like the morning star. Oh,

5 4 (-4) 5 (-5) (-4)  
Shoo, fly, don't bother me.  
(-4) (-3) 4 (-4) 5 4  
Shoo, fly, don't bother me.  
5 4 (-4) 5 (-5) (-4)  
Shoo, fly, don't bother me.  
(-4) 6 6 6 (-5) 5 (-4) 4  
For I belong to somebody.

## Shoo, Fly

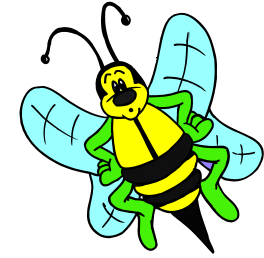

5 4 (-4) 5 (-5) (-4)  
Shoo, fly, don't bother me.  
(-4) (-3) 4 (-4) 5 4  
Shoo, fly, don't bother me.  
5 4 (-4) 5 (-5) (-4)  
Shoo, fly, don't bother me.  
(-4) 6 6 6 (-5) 5 (-4) 4  
For I belong to somebody.

3 5 5 5 5 5  
I feel, I feel, I feel,  
3 5 5 5 (-5) 5 (-4)  
I feel like the morning star.  
3 (-4) (-4) (-4) (-4) (-4) (-4) (-4)  
I feel, I feel, I feel, I feel,  
3 6 6 6 (-5) (-4) 4 6  
I feel like the morning star. Oh,

5 4 (-4) 5 (-5) (-4)  
Shoo, fly, don't bother me.  
(-4) (-3) 4 (-4) 5 4  
Shoo, fly, don't bother me.  
5 4 (-4) 5 (-5) (-4)  
Shoo, fly, don't bother me.  
(-4) 6 6 6 (-5) 5 (-4) 4  
For I belong to somebody.

## Polly Wolly Doodle – *Traditional*

4 (-4) 5 5 4 4 (-4) 5 5 4  
Oh, I went down south for to see my Sal,  
4 5 5 5 5 (-5) (-5) 5 5 (-4)  
Sing: Polly Wolly Doo-dle all the day;  
(-3) 4 (-4)(-4)(-3)(-3) (-4)(-4) (-3)  
Oh, my Sal-ly is a spun-ky gal,  
(-4) 6 6 6 6 (-5)(-5)(-4)(-4) 4  
Sing: Polly Wolly Doodle all the day.

4 (-4) 5 4 (-4) 5  
Fare thee well, fare thee well  
4 (-4) 5 5 (-5) 5 (-4)  
Fare thee well my fair-y fay  
(-3) 4 (-4) (-4) (-4)(-4)(-3)(-3)  
For I'm going to Louis-i-an-na  
(-3) 4 (-4)(-4)(-4)(-4)(-3)(-3)  
For to see my Su-sy-an-na  
(-4) 6 6 6 6 (-5)(-5)(-4)(-4) 4  
Sing: Pol-ly Wol-ly Doo-dle all the day.

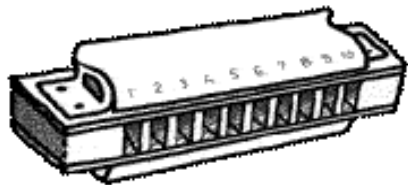

## Polly Wolly Doodle – *Traditional*

4 (-4) 5 5 4 4 (-4) 5 5 4  
Oh, I went down south for to see my Sal,  
4 5 5 5 5 (-5) (-5) 5 5 (-4)  
Sing: Polly Wolly Doo-dle all the day;  
(-3) 4 (-4)(-4)(-3)(-3) (-4)(-4) (-3)  
Oh, my Sal-ly is a spun-ky gal,  
(-4) 6 6 6 6 (-5)(-5)(-4)(-4) 4  
Sing: Polly Wolly Doodle all the day.

4 (-4) 5 4 (-4) 5  
Fare thee well, fare thee well  
4 (-4) 5 5 (-5) 5 (-4)  
Fare thee well my fair-y fay  
(-3) 4 (-4) (-4) (-4)(-4)(-3)(-3)  
For I'm going to Louis-i-an-na  
(-3) 4 (-4)(-4)(-4)(-4)(-3)(-3)  
For to see my Su-sy-an-na  
(-4) 6 6 6 6 (-5)(-5)(-4)(-4) 4  
Sing: Pol-ly Wol-ly Doo-dle all the day.



**Oh, My Darling, Clementine** – *Traditional*

4 4 4 3 5 5 5 4

In a cavern, in a canyon

4 5 6 6 (-5) 5 (-4)

Excavating for a mine

(-4) 5 (-5)(-5) 5(-4) 5 4

Dwelt a miner forty-niner

4 5 (-4) 3 (-3) (-4) 4

And his daughter, Clementine

4 4 4 3 5 5 5 4

Oh, my darling, oh, my darling

4 5 6 6 (-5) 5 (-4)

Oh, my darling, Clementine

(-4) 5 (-5) (-5) 5 (-4) 5 4

You are lost and gone for-ev-er

4 5 (-4) 3 (-3)(-4) 4

Dreadful sorry, Clementine.

**Ten in the Bed**

3 3 4 4 4 4

There were ten in the bed

3 3 4 4 4 4

And the lit-tle one said,

6 5 4 6 5 4

“Roll o-ver, roll o-ver.”

3 3 4 4 4 4 3 4 4 4

So they all rolled o-ver and one fell out. . .

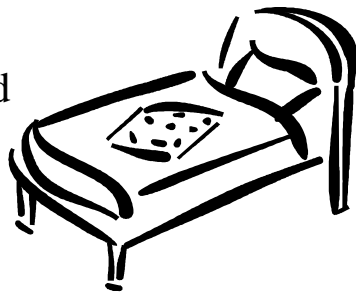

**Oh, My Darling, Clementine** – *Traditional*

4 4 4 3 5 5 5 4

In a cavern, in a canyon

4 5 6 6 (-5) 5 (-4)

Excavating for a mine

(-4) 5 (-5)(-5) 5(-4) 5 4

Dwelt a miner forty-niner

4 5 (-4) 3 (-3) (-4) 4

And his daughter, Clementine

4 4 4 3 5 5 5 4

Oh, my darling, oh, my darling

4 5 6 6 (-5) 5 (-4)

Oh, my darling, Clementine

(-4) 5 (-5) (-5) 5 (-4) 5 4

You are lost and gone for-ev-er

4 5 (-4) 3 (-3)(-4) 4

Dreadful sorry, Clementine.

**Ten in the Bed**

3 3 4 4 4 4

There were ten in the bed

3 3 4 4 4 4

And the lit-tle one said,

6 5 4 6 5 4

“Roll o-ver, roll o-ver.”

3 3 4 4 4 4 3 4 4 4

So they all rolled o-ver and one fell out. . .

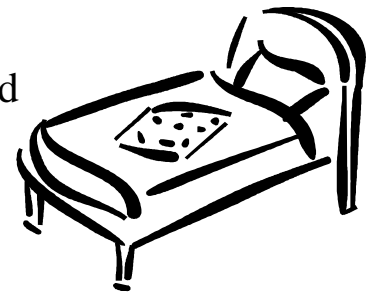

**On Top of Spaghetti**— *Traditional Parody*

4 4 5 6 7 (-6)

On top of spa-ghet-ti

(-6) (-5) 6 (-6) 6

All covered with cheese,

4 4 5 6 6 (-4)

I lost my poor meatball

5 (-5) 5 (-4) 4

When somebody sneezed.

It rolled off the table

And on to the floor

And then my poor meatball

It rolled out the door

It rolled in to the garden

And under a bush

And then my poor meatball

Was nothing but mush.

And early next summer

It grew in to a tree

All covered with meatballs

As big as could be.

So, if you like spaghetti

All covered with cheese

Hold on to your meatball

And don't ever sneeze!

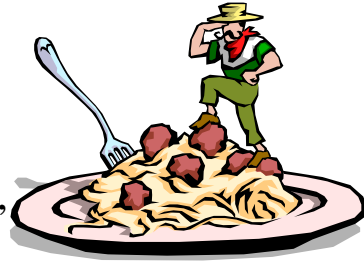

**On Top of Spaghetti**— *Traditional Parody*

4 4 5 6 7 (-6)

On top of spa-ghet-ti

(-6) (-5) 6 (-6) 6

All covered with cheese,

4 4 5 6 6 (-4)

I lost my poor meatball

5 (-5) 5 (-4) 4

When somebody sneezed.

It rolled off the table

And on to the floor

And then my poor meatball

It rolled out the door

It rolled in to the garden

And under a bush

And then my poor meatball

Was nothing but mush.

And early next summer

It grew in to a tree

All covered with meatballs

As big as could be.

So, if you like spaghetti

All covered with cheese

Hold on to your meatball

And don't ever sneeze!



## Camptown Races — Stephen Foster

6 6 5 6 (-6) 6 5  
Camptown ladies sing this song,

5 (-4) 5 (-4)  
Doo-dah! Doo-dah!

6 6 5 6 (-6) 6 5  
Camptown racetrack five miles long,

(-4) 5 (-4) 4  
Oh! Doo-dah day!

(4) (4) 5 (6) 7 (-6) (-6) 7 (-6) 6  
Gon-na run all night! Gon-na run all day.

6 6 5 5 6 6 (-6) 6 5  
Bet my money on the bobtail nag.

(-4) 5 (-5) 5 (-4) (-4) 4  
Somebody bet on the bay.



## Over My Head

4 4 4 5 4 4 5 5 (-4) (-4) 4  
O-ver my head I hear mu-sic in the air.

4 4 4 (-4) 4 4 5 5 (-4) (-4) 4  
O-ver my head I hear mu-sic in the air.

4 4 4 5 4 4 5 5 (-4) (-4) 4  
O-ver my head I hear mu-sic in the air.

4 (-4) (-4) (-4) 5 (-4) 4  
There must be a God some-where.

## Camptown Races — Stephen Foster

6 6 5 6 (-6) 6 5  
Camptown ladies sing this song,

5 (-4) 5 (-4)  
Doo-dah! Doo-dah!

6 6 5 6 (-6) 6 5  
Camptown racetrack five miles long,

(-4) 5 (-4) 4  
Oh! Doo-dah day!

(4) (4) 5 (6) 7 (-6) (-6) 7 (-6) 6  
Gon-na run all night! Gon-na run all day.

6 6 5 5 6 6 (-6) 6 5  
Bet my money on the bobtail nag.

(-4) 5 (-5) 5 (-4) (-4) 4  
Somebody bet on the bay.



## Over My Head

4 4 4 5 4 4 5 5 (-4) (-4) 4  
O-ver my head I hear mu-sic in the air.

4 4 4 (-4) 4 4 5 5 (-4) (-4) 4  
O-ver my head I hear mu-sic in the air.

4 4 4 5 4 4 5 5 (-4) (-4) 4  
O-ver my head I hear mu-sic in the air.

4 (-4) (-4) (-4) 5 (-4) 4  
There must be a God some-where.

## You Are My Sunshine

3 4 (4) 5 5  
You are my sun-shine,  
5 (4) 5 4 4  
My on-ly sun-shine,  
4 (4) 5 (5) (6)  
You make me hap-py  
(6) 6 (5) 5  
When skies are grey  
4 (4) 5 (5) (6)  
You'll nev-er know dear  
(6) 6 (5) 5 4  
How much I love you  
4 (4) 5 (5) (4) (4) 5 4  
Please don't take my sun-shine a-way.



## You Are My Sunshine

3 4 (4) 5 5  
You are my sun-shine,  
5 (4) 5 4 4  
My on-ly sun-shine,  
4 (4) 5 (5) (6)  
You make me hap-py  
(6) 6 (5) 5  
When skies are grey  
4 (4) 5 (5) (6)  
You'll nev-er know dear  
(6) 6 (5) 5 4  
How much I love you  
4 (4) 5 (5) (4) (4) 5 4  
Please don't take my sun-shine a-way.



## This Old Man

6 5 6 6 5 6  
This old man, he played ONE  
(6) 6 (5) 5 (4) 5 (5)  
He played nick nack on my THUMB  
5 (5) 6 4 4 4 4  
With a nick nack, paddy wack  
4 (4) 5 (5) 6  
Give your dog a bone,  
6 (4) (4) (5) 5 (4) 4  
This old man came rolling home.

## This Old Man

6 5 6 6 5 6  
This old man, he played ONE  
(6) 6 (5) 5 (4) 5 (5)  
He played nick nack on my THUMB  
5 (5) 6 4 4 4 4  
With a nick nack, paddy wack  
4 (4) 5 (5) 6  
Give your dog a bone,  
6 (4) (4) (5) 5 (4) 4  
This old man came rolling home.

**Scotland's Burning** - Round

3 3 4 4 3 3 4 4

Scot-land's burn-ing, Scot-land's burn-ing,

(-4) 5 (-4) 5

Look out! Look out!

6 6 6 6

Fire! Fire! Fire! Fire!

3 3 4 4 3 3 4 4

Pour on wat-er, pour on wat-er.



**Scotland's Burning** - Round

3 3 4 4 3 3 4 4

Scot-land's burn-ing, Scot-land's burn-ing,

(-4) 5 (-4) 5

Look out! Look out!

6 6 6 6

Fire! Fire! Fire! Fire!

3 3 4 4 3 3 4 4

Pour on wat-er, pour on wat-er.



**My Bonnie Lies Over the Ocean**

6 8 (-8) 7 (-8) 7 (-6) 6 5

My Bon-nie lies ov-er the o-cean,

6 8 (-8) 7 7 (-7) 7 (-8)

My Bon-nie lies ov-er the sea,

6 8 (-8) 7 (-8) 7 (-6) 6 5

My Bon-nie lies ov-er the o-cean.

6 (-6) (-8) 7 (-7) (-6) (-7) 7

Oh, bring back my Bon-nie to me

6 7 (-6) (-8)

Bring back, bring back,

7 (-7) (-7) (-7) (-7) (-6) (-7) 7 (-8) 8

Oh bring back my Bon-nie to me, to me,

6 7 (-6) (-8)

Bring back, bring back,

7 (-7) (-7) (-7) (-7) (-6) (-7) 7

Oh bring back my Bon-nie to me.

**My Bonnie Lies Over the Ocean**

6 8 (-8) 7 (-8) 7 (-6) 6 5

My Bon-nie lies ov-er the o-cean,

6 8 (-8) 7 7 (-7) 7 (-8)

My Bon-nie lies ov-er the sea,

6 8 (-8) 7 (-8) 7 (-6) 6 5

My Bon-nie lies ov-er the o-cean.

6 (-6) (-8) 7 (-7) (-6) (-7) 7

Oh, bring back my Bon-nie to me

6 7 (-6) (-8)

Bring back, bring back,

7 (-7) (-7) (-7) (-7) (-6) (-7) 7 (-8) 8

Oh bring back my Bon-nie to me, to me,

6 7 (-6) (-8)

Bring back, bring back,

7 (-7) (-7) (-7) (-7) (-6) (-7) 7

Oh bring back my Bon-nie to me.

## Rain, Rain, Go Away

6 5 6 6 5

Rain, rain, go a- way.

6 6 5 (-6) 6 6 5

Come a-gain an-oth-er day.



## Rain, Rain, Go Away

6 5 6 6 5

Rain, rain, go a- way.

6 6 5 (-6) 6 6 5

Come a-gain an-oth-er day.

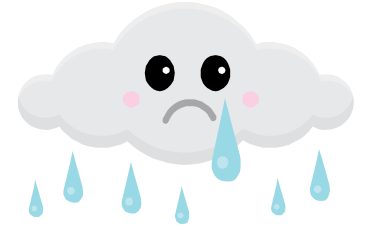

## It's Raining, It's Pouring

6 6 5 (-6) 6 5

It's rain-ing. It's pour-ing.

5 6 5 (-6) 6 5

The old man is snor-ing.

6 6 5 5 (-6) 6 6 5

Went to bed and he bumped his head,

5 (-6) 6 6 6 5 5 (-6) 6 5

And he couldn't get up in the morn-ing.

## It's Raining, It's Pouring

6 6 5 (-6) 6 5

It's rain-ing. It's pour-ing.

5 6 5 (-6) 6 5

The old man is snor-ing.

6 6 5 5 (-6) 6 6 5

Went to bed and he bumped his head,

5 (-6) 6 6 6 5 5 (-6) 6 5

And he couldn't get up in the morn-ing.

## Are You Sleeping

4 (-4) 5 4 4 (-4) 5 4

Are you sleep-ing? Are you sleep-ing?

5 (-5) 6 5 (-5) 6

Brother John, Brother John,

6 (-6) 6 (-5) 5 4

Morning bells are ring-ing.

6 (-6) 6 (-5) 5 4

Morning bells are ring-ing.

4 3 4 4 3 4

Ding, dong, ding, Ding, dong, ding.



## Are You Sleeping

4 (-4) 5 4 4 (-4) 5 4

Are you sleep-ing? Are you sleep-ing?

5 (-5) 6 5 (-5) 6

Brother John, Brother John,

6 (-6) 6 (-5) 5 4

Morning bells are ring-ing.

6 (-6) 6 (-5) 5 4

Morning bells are ring-ing.

4 3 4 4 3 4

Ding, dong, ding, Ding, dong, ding.





## Row, Row, Row Your Boat

4 4 4 (-4) 5  
Row, row, row your boat  
5 (-4) 5 (-5) 6  
Gent-ly down the stream.

7 7 7 6 6 6 5 5 5 4 4 4  
Mer-ri-ly, mer-ri-ly, mer-ri-ly, mer-ri-ly,  
6 (-5) 5 (-4) 4  
Life is but a dream.



## Amazing Grace

6 7 7 8 7 8 (-8) 7 (-6) 6  
A - maz-ing grace, how sweet the sound  
6 7 7 8 7 8 (-8) 9 9  
That saved a wretch like me.  
8 9 9 8 9 8 7 6 (-6) 7 7 (-6) 6  
I once was lost, but now am found,  
6 7 7 8 7 8 (-8) 7  
Was blind, but now I see.

## Row, Row, Row Your Boat

4 4 4 (-4) 5  
Row, row, row your boat  
5 (-4) 5 (-5) 6  
Gent-ly down the stream.

7 7 7 6 6 6 5 5 5 4 4 4  
Mer-ri-ly, mer-ri-ly, mer-ri-ly, mer-ri-ly,  
6 (-5) 5 (-4) 4  
Life is but a dream.



## Amazing Grace

6 7 7 8 7 8 (-8) 7 (-6) 6  
A - maz-ing grace, how sweet the sound  
6 7 7 8 7 8 (-8) 9 9  
That saved a wretch like me.  
8 9 9 8 9 8 7 6 (-6) 7 7 (-6) 6  
I once was lost, but now am found,  
6 7 7 8 7 8 (-8) 7  
Was blind, but now I see.

## This Land Is Your Land

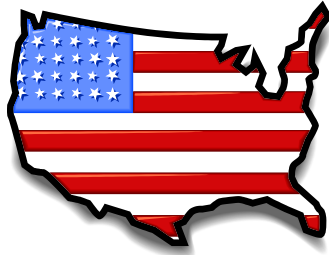

4 (-4) 5 (-5) (-5)  
This land is your land.

(-5) 4 (-4) 5 5  
This land is my land.

5 4 5 (-4) (-4) (-4) (-4) 4 (-4) 5 5  
From Cal-i-for-nia to the New York Island.

4 4 (-4) 5 (-5) (-5)  
From the Red-wood For-est

(-5) (-5) 4 (-4) 5 5  
To the Gulf Stream wat-ers

(-4) (-4) (-4) (-3) 3 (-3) (-4) 4  
This land was made for you and me.

## America

4 4 (-4) (-3) 4 (-4)  
My coun-try 'tis of thee,

5 5 (-5) 5 (-4) 4 (-4) 4 (-3) 4  
Sweet land of lib-er-ty, of thee I sing.

6 6 6 6 (-5) 5  
Land where my fath-ers died,

(-5) (-5) (-5) (-5) 5 (-4)  
Land of the Pil-grims' pride,

5 (-5) 5 (-4) 4 5 (-5) 6  
From ev' - ry moun-tain side,

(-6) (-5) 5 (-4) 4  
Let free-dom ring.

## This Land Is Your Land

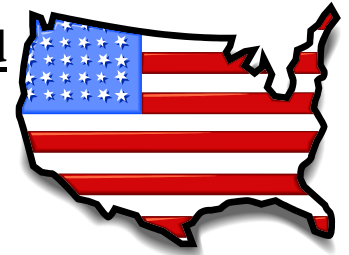

4 (-4) 5 (-5) (-5)  
This land is your land.

(-5) 4 (-4) 5 5  
This land is my land.

5 4 5 (-4) (-4) (-4) (-4) 4 (-4) 5 5  
From Cal-i-for-nia to the New York Island.

4 4 (-4) 5 (-5) (-5)  
From the Red-wood For-est

(-5) (-5) 4 (-4) 5 5  
To the Gulf Stream wat-ers

(-4) (-4) (-4) (-3) 3 (-3) (-4) 4  
This land was made for you and me.

## America

4 4 (-4) (-3) 4 (-4)  
My coun-try 'tis of thee,

5 5 (-5) 5 (-4) 4 (-4) 4 (-3) 4  
Sweet land of lib-er-ty, of thee I sing.

6 6 6 6 (-5) 5  
Land where my fath-ers died,

(-5) (-5) (-5) (-5) 5 (-4)  
Land of the Pil-grims' pride,

5 (-5) 5 (-4) 4 5 (-5) 6  
From ev' - ry moun-tain side,

(-6) (-5) 5 (-4) 4  
Let free-dom ring.

## Yankee Doodle

7 7 (-8) 8 7 8 (-8)  
Yan-kee Doo-dle went to town

6 7 7 (-8) 8 7 (-7)  
A-riding on a po-ny.

7 7 (-8) 8 (-9) 8 (-8)  
Stuck a feath-er in his hat

7 (-7) 6 (-6) (-7) 7 7  
And called it mac-a-ro-ni.

(-6) (-7) (-6) 6 (-6) (-7) 7  
Yan-kee Doo-dle keep it up,

6 (-6) 6 (-5) 5 6  
Yan-kee Doo-dle Dan-dy.

(-6) (-7) (-6) 6 (-6) (-7) 7  
Mind the mu-sic and the step,

(-6) 6 7 (-7) (-8) 7 7  
And with the girls be han-dy.



## Yankee Doodle

7 7 (-8) 8 7 8 (-8)  
Yan-kee Doo-dle went to town

6 7 7 (-8) 8 7 (-7)  
A-riding on a po-ny.

7 7 (-8) 8 (-9) 8 (-8)  
Stuck a feath-er in his hat

7 (-7) 6 (-6) (-7) 7 7  
And called it mac-a-ro-ni.

(-6) (-7) (-6) 6 (-6) (-7) 7  
Yan-kee Doo-dle keep it up,

6 (-6) 6 (-5) 5 6  
Yan-kee Doo-dle Dan-dy.

(-6) (-7) (-6) 6 (-6) (-7) 7  
Mind the mu-sic and the step,

(-6) 6 7 (-7) (-8) 7 7  
And with the girls be han-dy.



## Happy Birthday

6 6 (6) 6 7 (7)

Hap-py birth-day to you,

6 6 (6) 6 (8) 7

Hap-py birth-day to you,

6 6 9 8 7 (7) (6)

Hap-py birth-day dear \_\_\_\_\_

(9) (9) 8 7 (8) 7

Hap-py birth-day to you.



## Happy Birthday

6 6 (6) 6 7 (7)

Hap-py birth-day to you,

6 6 (6) 6 (8) 7

Hap-py birth-day to you,

6 6 9 8 7 (7) (6)

Hap-py birth-day dear \_\_\_\_\_

(9) (9) 8 7 (8) 7

Hap-py birth-day to you.



## I've Been Working on the Railroad

7 6 7 6 7(8) 8 7

I've been work-in' on the rail-road,

(9)(9) 7 (8) 8

All the live-long day;

7 6 7 6 7(8) 8 7

I've been work-in' on the rail-road,

8 8 8 (8) (8) 8(8)

Just to pass the time a-way.

(8) (8) 7 (8) 8 (8) 7 6

Don't you hear the whis-tle blow-in'

(9)(9)(9) 7 7 (8) (8) 8

Rise up so ear-ly in the morn,

(6) (7) 7 (7) 7 (6) 6 7

Don't you hear the cap-tain shout-in'

8 (9) 8 (8) 7

"Din-ah, blow your horn."

## I've Been Working on the Railroad

7 6 7 6 7(8) 8 7

I've been work-in' on the rail-road,

(9)(9) 7 (8) 8

All the live-long day;

7 6 7 6 7(8) 8 7

I've been work-in' on the rail-road,

8 8 8 (8) (8) 8(8)

Just to pass the time a-way.

(8) (8) 7 (8) 8 (8) 7 6

Don't you hear the whis-tle blow-in'

(9)(9)(9) 7 7 (8) (8) 8

Rise up so ear-ly in the morn,

(6) (7) 7 (7) 7 (6) 6 7

Don't you hear the cap-tain shout-in'

8 (9) 8 (8) 7

"Din-ah, blow your horn."

## I've Been Working on the Railroad *cont*

6 6 6 6 7

Din-ah, won't you blow,

(-6)(-6) (-6) (-6)(-8)

Din-ah, won't you blow,

(-7)(-7) (-7) (-7) (-6) (-7) 7(-8) 8

Din-ah, won't you blow your h-o-r-n,

6 6 6 6 7

Din-ah, won't you blow,

(-6)(-6) (-6) (-6) (-8)

Din-ah, won't you blow,

(-7)(-7) (-7) (-7) (-6) (-7) 7

Din-ah, won't you blow your horn.

8 8 8 8 7 7 7 6 7

Some-one's in the kitch-en with Din-ah,

8 8 8 8 7 7 7(-8)(-7)(-6) 6

Some-one's in the kitch-en I k-n-o-w.

8 8 8 8 7 7 7 (-9) (-10)

Some-one's in the kitch-en with Din-ah,

9 9 9 9 (-9)(-8) 7

Strum-min' on the old ban-jo.



## I've Been Working on the Railroad *cont*

6 6 6 6 7

Din-ah, won't you blow,

(-6)(-6) (-6) (-6)(-8)

Din-ah, won't you blow,

(-7)(-7) (-7) (-7) (-6) (-7) 7(-8) 8

Din-ah, won't you blow your h-o-r-n,

6 6 6 6 7

Din-ah, won't you blow,

(-6)(-6) (-6) (-6) (-8)

Din-ah, won't you blow,

(-7)(-7) (-7) (-7) (-6) (-7) 7

Din-ah, won't you blow your horn.

8 8 8 8 7 7 7 6 7

Some-one's in the kitch-en with Din-ah,

8 8 8 8 7 7 7(-8)(-7)(-6) 6

Some-one's in the kitch-en I k-n-o-w.

8 8 8 8 7 7 7 (-9) (-10)

Some-one's in the kitch-en with Din-ah,

9 9 9 9 (-9)(-8) 7

Strum-min' on the old ban-jo.



## Puff the Magic Dragon

7 7 7 7 (-7) 6 (-6) 7 7 6  
Puff, the mag-ic drag-on, lived by the sea  
6 (-5) (-5) 6 (-5) 5 6 7  
and frolicked in the au-tumn mist  
77 7 (-6) (-7) 7 (-8)  
in a land called Ho-nah-lee.



7 7 7 7 (-7) 6 (-6) 7 7 6  
Puff, the mag-ic drag-on, lived by the sea  
6 (-5) (-5) 6 (-5) 5 6 7  
And frolicked in the au-tumn mist  
77 (-6) 7 (-7) (-8) 7  
in a land called Ho-nah-lee.

## Somewhere Over the Rainbow

4 7 (-7) 6 (-6) (-7) 7 4 (-6) 6  
Somewhere over the rainbow way up high  
4 (-6) 6 5 (-5) 6 (-6) (-4) (-3) 4 (-4) 5 4  
there's a land that I heard of once in a lull-a-by  
4 7 (-7) 6 (-6) (-7) 7 4 (-6) 6  
Somewhere over the rainbow skies are blue.  
4 (-6) 6 5 (-5) 6 (-6) (-4)  
And the dreams that you dare to dream  
(-3) 4 (-4) 5 4  
really do come true.

## Puff the Magic Dragon

7 7 7 7 (-7) 6 (-6) 7 7 6  
Puff, the mag-ic drag-on, lived by the sea  
6 (-5) (-5) 6 (-5) 5 6 7  
and frolicked in the au-tumn mist  
77 7 (-6) (-7) 7 (-8)  
in a land called Ho-nah-lee.



7 7 7 7 (-7) 6 (-6) 7 7 6  
Puff, the mag-ic drag-on, lived by the sea  
6 (-5) (-5) 6 (-5) 5 6 7  
And frolicked in the au-tumn mist  
77 (-6) 7 (-7) (-8) 7  
in a land called Ho-nah-lee.

## Somewhere Over the Rainbow

4 7 (-7) 6 (-6) (-7) 7 4 (-6) 6  
Somewhere over the rainbow way up high  
4 (-6) 6 5 (-5) 6 (-6) (-4) (-3) 4 (-4) 5 4  
there's a land that I heard of once in a lull-a-by  
4 7 (-7) 6 (-6) (-7) 7 4 (-6) 6  
Somewhere over the rainbow skies are blue.  
4 (-6) 6 5 (-5) 6 (-6) (-4)  
And the dreams that you dare to dream  
(-3) 4 (-4) 5 4  
really do come true.

**The Marvelous Toy** — *Tom Paxton*

6 6 4 4 4 4

It went zip when it moved

5 (-4) (-4) (-4) (-4)

and bop when it stopped

(-4) 4 4 5 6 (-5)

and whir when it stood still

(-6)(-6)(-6) 7 (-6) 6 6 5

I nev-er knew just what it was

4 4 (-4) (-5) 5 (-4) 4

and I guess I nev-er will!

**Ode to Joy**



5 5 (-5) 6 6 (-5) 5 (-4)

3 3 (-4) 5 5 (-4) (-4)

5 5 (-5) 6 6 (-5) 5 (-4)

3 3 (-4) 5 (-4) 3 3

(-4) (-4) 5 3 (-4) 5 (-5) 5 3

(-4) 5 (-5) 5 (-4) 3 (-4) 2

5 5 (-5) 6 6 (-5) 5 (-4)

3 3 (-4) 5 (-4) 3 3

**The Marvelous Toy** — *Tom Paxton*

6 6 4 4 4 4

It went zip when it moved

5 (-4) (-4) (-4) (-4)

and bop when it stopped

(-4) 4 4 5 6 (-5)

and whir when it stood still

(-6)(-6)(-6) 7 (-6) 6 6 5

I nev-er knew just what it was

4 4 (-4) (-5) 5 (-4) 4

and I guess I nev-er will!

**Ode to Joy**



5 5 (-5) 6 6 (-5) 5 (-4)

3 3 (-4) 5 5 (-4) (-4)

5 5 (-5) 6 6 (-5) 5 (-4)

3 3 (-4) 5 (-4) 3 3

(-4) (-4) 5 3 (-4) 5 (-5) 5 3

(-4) 5 (-5) 5 (-4) 3 (-4) 2

5 5 (-5) 6 6 (-5) 5 (-4)

3 3 (-4) 5 (-4) 3 3

## Chicken on the Fencepost

—Play-Party Song

(-5) (-5) (-5) (-5) (-5) (-5) (-6) 6 (-6) 7  
Chick-en on the fence post, can't dance Jo-sey,  
(-5) (-5) (-5) (-5) (-5) (-5) 6 (-5) (-4) 4  
Chick-en on the fence post, can't dance Jo-sey,  
(-5) (-5) (-5) (-5) (-5) (-5) (-6) 5 (-6) 7  
Chick-en on the fence post, can't dance Jo-sey,  
(-8) 7 (-6) 6 (-5) (-5) (-5)  
Hel-lo, Su-san Brown -y -o



## Tideo

— Ohio Play-Party Song

5 6 6 (-6) 5 6 6  
Pass one win-dow, ti-de-o.  
5 6 6 (-6) 5 (-4) (-4)  
Pass two win-dows, ti-de-o  
5 6 6 (-6) 5 6 6  
Pass three win-dows, ti-de-o.  
6 6 6 6 6 (-6) 5 (-4) 4  
Jin-gle at the win-dows, ti-de-o.  
5 6 7 5 6 7  
Ti-de-o, ti-de-o,  
6 6 6 6 6 (-6) 5 (-4) 4  
Jin-gle at the win-dows, ti-de-o.

## Chicken on the Fencepost

—Play-Party Song

(-5) (-5) (-5) (-5) (-5) (-5) (-6) 6 (-6) 7  
Chick-en on the fence post, can't dance Jo-sey,  
(-5) (-5) (-5) (-5) (-5) (-5) 6 (-5) (-4) 4  
Chick-en on the fence post, can't dance Jo-sey,  
(-5) (-5) (-5) (-5) (-5) (-5) (-6) 5 (-6) 7  
Chick-en on the fence post, can't dance Jo-sey,  
(-8) 7 (-6) 6 (-5) (-5) (-5)  
Hel-lo, Su-san Brown -y -o



## Tideo

— Ohio Play-Party Song

5 6 6 (-6) 5 6 6  
Pass one win-dow, ti-de-o.  
5 6 6 (-6) 5 (-4) (-4)  
Pass two win-dows, ti-de-o  
5 6 6 (-6) 5 6 6  
Pass three win-dows, ti-de-o.  
6 6 6 6 6 (-6) 5 (-4) 4  
Jin-gle at the win-dows, ti-de-o.  
5 6 7 5 6 7  
Ti-de-o, ti-de-o,  
6 6 6 6 6 (-6) 5 (-4) 4  
Jin-gle at the win-dows, ti-de-o.



## Death of the Robin

— American Folk Song

(-7) (-7) (-6) (-7) 5 5

Who killed Bro-ther Ro-bin?

(-6) (-6) (-6) 6 5 5

Who killed Bro-ther Ro-bin?

8 (-7) (-7) (-7) (-7)

I cried the spar-row

6 6 (-6) (-7) (-6) 6 5 5

with my lit-tle bow and ar-row.

5 5 6 (-6) (-7) (-6) 6 5

It was I, oh it was I.

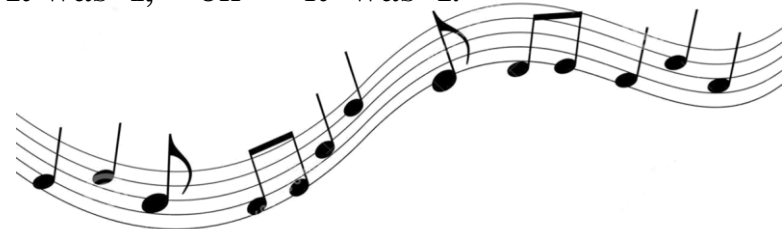
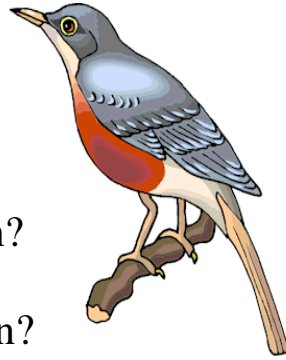

## Death of the Robin

— American Folk Song

(-7) (-7) (-6) (-7) 5 5

Who killed Bro-ther Ro-bin?

(-6) (-6) (-6) 6 5 5

Who killed Bro-ther Ro-bin?

8 (-7) (-7) (-7) (-7)

I cried the spar-row

6 6 (-6) (-7) (-6) 6 5 5

with my lit-tle bow and ar-row.

5 5 6 (-6) (-7) (-6) 6 5

It was I, oh it was I.



## This Is My Country — Raye/Jacobs

4 4 7 (-6) 6 5 5 4 6

This is my coun-try, land of my birth.

4 4 7 (-6) 6 5 5 4 6

This is my coun-try, grand-est on earth.

(-6) (-5) 4 (-5) (-6) 7 6 6 (-6) (-6) (-6) (-5) (-7)

I pledge thee my allegiance, A-merica, the bold

6 7 (-6) 7 (-6) 6 (-6) 7 7 (-7) 7

For this is my coun-try, to have and to hold.

## This Is My Country — Raye/Jacobs

4 4 7 (-6) 6 5 5 4 6

This is my coun-try, land of my birth.

4 4 7 (-6) 6 5 5 4 6

This is my coun-try, grand-est on earth.

(-6) (-5) 4 (-5) (-6) 7 6 6 (-6) (-6) (-6) (-5) (-7)

I pledge thee my allegiance, A-merica, the bold

6 7 (-6) 7 (-6) 6 (-6) 7 7 (-7) 7

For this is my coun-try, to have and to hold.

## Tips for taking care of your harmonica:

- ♪ Don't eat and play your harmonica.
- ♪ Don't drink anything but water before playing.
- ♪ Rinse your mouth out well, or brush your teeth if necessary, before playing.
- ♪ Keep your harmonica in its plastic case if you aren't playing it.
- ♪ Pay attention to where you put it down—it's small and can easily be misplaced.
- ♪ Tap your harmonica out gently after playing—holes down—to get out excess saliva.
- ♪ Don't let others play your harmonica!

## How It Works:

The things that make the sound are thin strips of metal called REEDS. Your harmonica's reeds are only 3/8" to 5/8". Small things can get caught in the harmonica and make it sound bad or not sound at all so keep your harmonica CLEAN!

To hear how the reeds are working for you, blow into the lower part of the harmonica and then hold that part up to your ear quickly—you'll hear the reeds still vibrating.

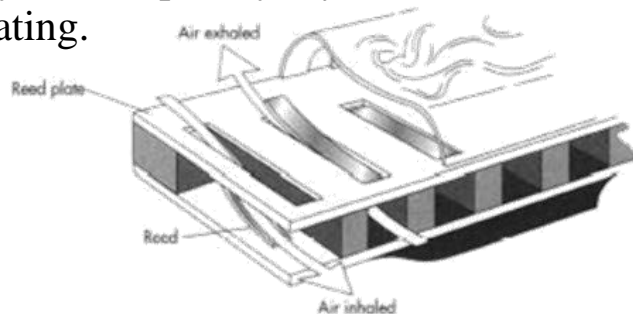

## Tips for taking care of your harmonica:

- ♪ Don't eat and play your harmonica.
- ♪ Don't drink anything but water before playing.
- ♪ Rinse your mouth out well, or brush your teeth if necessary, before playing.
- ♪ Keep your harmonica in its plastic case if you aren't playing it.
- ♪ Pay attention to where you put it down—it's small and can easily be misplaced.
- ♪ Tap your harmonica out gently after playing—holes down—to get out excess saliva.
- ♪ Don't let others play your harmonica!

## How It Works:

The things that make the sound are thin strips of metal called REEDS. Your harmonica's reeds are only 3/8" to 5/8". Small things can get caught in the harmonica and make it sound bad or not sound at all so keep your harmonica CLEAN!

To hear how the reeds are working for you, blow into the lower part of the harmonica and then hold that part up to your ear quickly—you'll hear the reeds still vibrating.

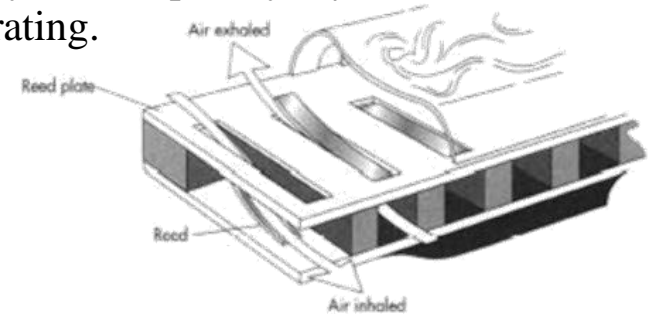

## Harmonica Parts:

The harmonica has three basic parts:  
the comb, the reed plates and the cover plates.

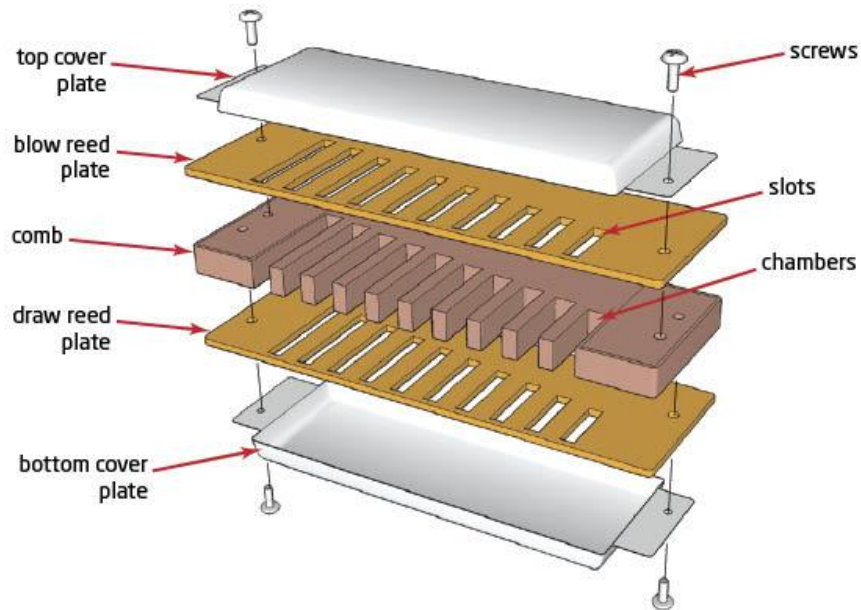

## Train Sound:

4/4 :||  
D D B B D D chug-ga chug-ga

*This handbook was created by Janet Gore and Judy Meyer Hays for elementary students to learn how to play the harmonica. If any copyright has been violated, please contact me and I will modify our work. [Judy@MakeJoyfulSound.org](mailto:Judy@MakeJoyfulSound.org)*

## Harmonica Parts:

The harmonica has three basic parts:  
the comb, the reed plates and the cover plates.

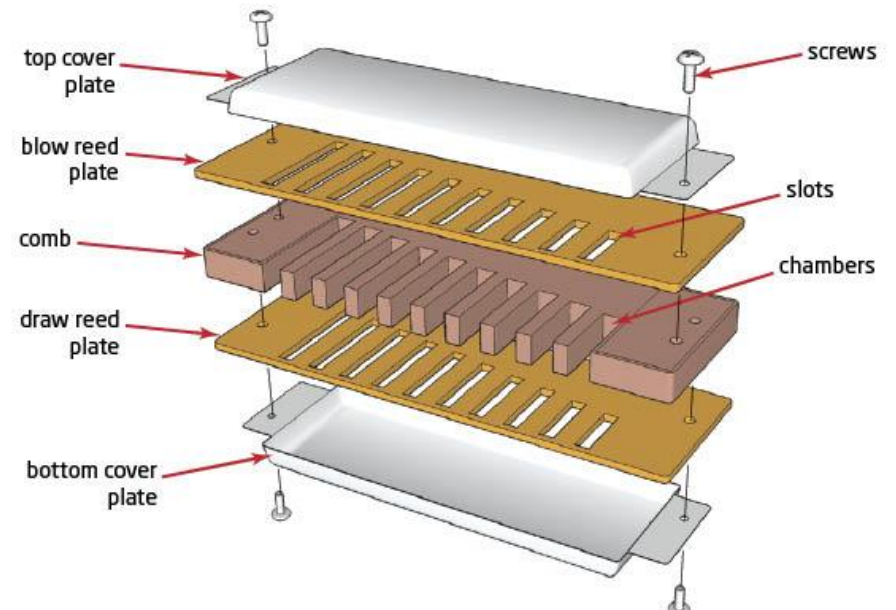

## Train Sound:

4/4 :||  
D D B B D D chug-ga chug-ga

*This handbook was created by Janet Gore and Judy Meyer Hays for elementary students to learn how to play the harmonica. If any copyright has been violated, please contact me and I will modify our work. [Judy@MakeJoyfulSound.org](mailto:Judy@MakeJoyfulSound.org)*



<http://www.makejoyfulsound.org>



<http://www.makejoyfulsound.org>