



***HERRAMIENTA PARA TUBO / PIPE TOOLS / OUTILLAGE TUBE / ROHR WERKZEUGE /  
UTENSILI PER TUBI / FERRAMENTA PARA TUBOS / ТРУБНЫЙ ИНСТРУМЕНТ***

# 13 MASTERGRIP

PREMIO A LA MEJOR IDEA EN HERRAMIENTAS  
BEST TOOL AWARD  
PRIX A LA MEILLEURE IDÉE EN OUTILS



“CLUB DE INVENTORES ESPAÑOLES”



**Medalla**, Salón Internacional de la Invención, París 2007

**Medal**, International Inventors Competition, París 2007

**Medaille**, Salon International de L'Invention, París 2007



Premio Iberferr al **Mejor Producto del Año**, 2007

2007 **Best Product Award** by Iberferr Sectorial Magazine

Prix Iberferr du **meilleur produit** de l'année, 2007

La rapidez y facilidad de uso con una mano de la llave para tubo Mastergrip, con capacidad para tubos de medidas comprendidas entre 1/4" y 1.1/2" para la de 10", entre 1/2" y 2" en el caso de la de 14" y entre 3/4" y 3" para la de 18", ofrecen una sujeción ideal para empalmar con gran eficacia tubos roscados. Su especial diseño robusto permite ser empleado en trabajos pesados.

The fast and easy one-handed operated Mastergrip provides perfect grip to fit pipes effective and efficiently. The special Heavy Duty design makes it ideal for the most demanding jobs, providing 1/4"-1.1/4" pipe capacity for the 10" version, 1/2" to 2" in the 14" version and 3/4" to 3" in the 18" version, provides also a ratchet function that makes threaded pipe fitting really efficient. Heavy duty type for the most demanding jobs.

La rapidité et la facilité d'utilisation avec une seule main de la clé serre-tubes Mastergrip, avec une capacité pour les tubes selon des mesures comprises entre 1/4" et 1.1/2" pour celle de 10", entre 1/2" et 2" dans le cas de celle de 14" et entre 3/4" et 3" pour celle de 18", permettent une prise idéale pour raccorder avec une grande efficacité des tubes filetés. Sa conception spécialement robuste permet de l'utiliser pour des travaux durs.

**1.** Su exclusivo diseño geométrico de lengua y postizo con un dentado especial permiten un agarre perfecto.

Designed with special teeth for the best pipe gripping effect.

La géométrie exclusive de la mâchoire et du bras de levier, pourvus d'une denture spéciale, permet une prise parfaite du tube, tout en donnant un effet cliquet.

**3.** Postizo con chaveta para soportar esfuerzos en ambos sentidos.

Heel jaw with sunk key to withstand efforts in both directions.

Bras de levier avec un axe pour supporter des forces des deux côtés.

**5.** Patentada

Patented

Brevetée

**2.** Mango ergonómico de fundición de precisión de inmejorable atractivo.

Ergonomic handle in accurate casting make it unbeatably attractive.

Manche ergonomique en fonte de précision, ayant un parfait attrait.

**4.** Fácil amarre del tubo con una sola mano.

Easy one hand gripping.

Prise aisée du tube avec une seule main.



1/4"



3/8"



1/2"



3/4"



1"



1.1/4"



1.1/2"



2"



2.1/2"



3"

# 13 HERRAMIENTA PARA TUBO / PIPE TOOLS / OUTILLAGE TUBE / ROHR WERKZEUGE / UTENSILI PER TUBI / FERRAMENTA PARA TUBOS / ТРУБНЫЙ ИНСТРУМЕНТ

LLAVES PARA TUBO / PIPE WRENCHES / CLÉS SERRE-TUBES / EINHAND ROHRZANGE / GIRATUBI / CHAVES PARA TUBOS / ТРУБНЫЕ КЛЮЧИ

MASTERGRIP

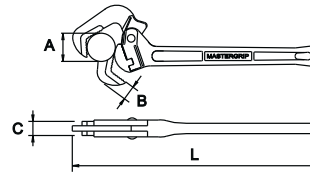

COD	L	A	B	C	Hex	Kg.	Box	Case
61405	10"	1/4"-1.1/2"	15	26	13-46mm	0,9		
61406	14"	1/2"-2"	23	33	17-50mm	1,6	1	1



ALUMINIO / ALUMINIUM

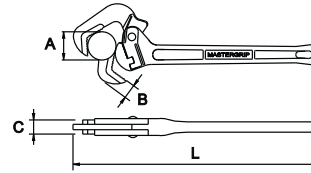

COD	L	A	B	C	Hex	Kg.	Box	Case
61407	18"	3/4"-3"	29	50	17-80mm	2,5	1	1

REPUESTOS MASTERGRIP / MASTERGRIP SPARE PARTS / PIÈCES DE RECHANGE MASTERGRIP / MASTERGRIP ERSATZTEILE / RICAMBI MASTERGRIP / COMPONENTES MASTERGRIP / ЗАПАСНЫЕ ЧАСТИ ДЛЯ MASTERGRIP

Size	Heel Jaw	Hook Jaw	Spring	Axle
10"	80326	80327	80324	80325
14"	80329	80330	80315	80320
18"	80566	80567	80568	80569

	Mordaza inferior / Heel Jaw / <i>Machoire inférieure</i>
	Lengua / Hook Jaw / <i>Bec</i>
	Muelle / Spring / <i>Ressort</i>
	Eje / Axle / <i>Axe</i>

LLAVES STILLSON / STILLSON PIPE WRENCHES / CLÉS STILLSON / STILLSON ROHRZANGE / GIRATUBI MODELLO STILLSON / CHAVES STILLSON / ТРУБНЫЕ КЛЮЧИ STILLSON

REFORZADA / REINFORCED / RENFORCEE / VERSTARK / RINFORZATA / REFORÇADA / УСИЛЕННЫЕ

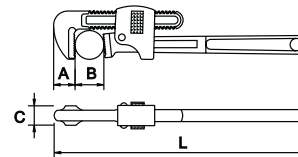

COD	L	A	B	C	Kg.	Box	Case
61001	8"	17	3/4"	12	0,3		
61002	10"	23	1"	16	0,6		
61003	12"	24	1.1/4"	16	0,8		1
61004	14"	28	1.1/2"	21	1,1	1	
61005	18"	30	2"	24	1,9		
61006	24"	39	2.1/2"	27	3,1		
61007	36"	49	4"	30	6,5		

UNE 16552 / BS 3594-1 / GGG-W-00651d

REPUESTOS LLAVE STILLSON / STILLSON WRENCH SPARE PARTS / PIÈCES DE RECHANGE CLÉ STILLSON / STILLSON ROHRZANGE ERSATZTEILEN / RICAMBI CHIAVI STILLSON / COMPONENTES DE CHAVE STILSON / ЗАПАСНЫЕ ЧАСТИ ДЛЯ STILLSON

Size	Spring Set	Nut	Hook Jaw
8"	80047	80040	80033
10"	80048	80041	80034
12"	80049	80042	80035
14"	80050	80043	80036
18"	80051	80044	80037
24"	80052	80045	80038
36"	80053	80046	80039

	Juego muelles / Spring Set / <i>Jeu de ressorts</i>
	Tuerca / Nut / <i>Ecrou</i>
	Lengua / Hook Jaw / <i>Bec</i>

# 13 HERRAMIENTA PARA TUBO / PIPE TOOLS / OUTILLAGE TUBE / ROHR WERKZEUGE / UTENSILI PER TUBI / FERRAMENTA PARA TUBOS / ТРУБНЫЙ ИНСТРУМЕНТ

LLAVE HEAVY DUTY / HEAVY DUTY PIPE WRENCH / CLÉ SERRE-TUBES HEAVY DUTY / HEAVY DUTY ROHRZANGE / GIRATUBI MODELLO AMERICANO PESANTE / CHAVE HEAVY DUTY / ТРУБНЫЕ КЛЮЧИ ДЛЯ БОЛЬШИХ НАГРУЗОК

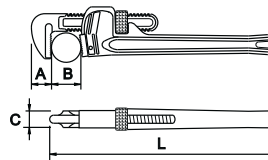

COD	L	A	B	C	Kg.		
61299	6"	13	3/4"	11	0,2		
61014	8"	15	1"	14	0,4		
61015	10"	20	1.1/2"	17	0,8	6	1
61016	12"	23		20	1,3		
61017	14"	25	2"	23	1,7	3	
61018	18"	28	2.1/2"	26	2,6		
61019	24"	33	3"	29	4,5		
61020	36"	43	5"	33	9,5	1	-
61021	48"	55	6"	35	14		
61045	60"	85	8"	41	20		

GGG-W-651-E, Type II Class A

### Especificaciones técnicas / Technical specification / Détails techniques

Lengua forjada móvil con efecto carraca / Floating forged hook for ratcheting action / Langue forgée mobile avec effet cliquet

Lengua graduada para un ajuste rápido / Graduated hook for quick adjustment / Langue graduée pour un réglage rapide

Mordaza inferior de aleación de acero reemplazable. Dientes sesgados, fresados con gran precisión para un óptimo agarre y mayor durabilidad / Replaceable, twice hardened alloy steel jaws. Precision-milled, biased teeth for optimum gripping and lifetime / Mâchoire inférieure d'alliage en acier remplaçable. Dents tordues, fraisées avec une grande précision pour une adhérence optimale et une plus grande durabilité

Sobrepasa las especificaciones de la norma americana GGG-W651e en un 180% / Exceeds US fed GGG-W-651e specifications by over 180% / Dépasse les caractéristiques de la norme américaine GGG-W651w à la hauteur de 180%

Fabricada en fundición nodular de precisión APC / Made of accurate ductile casting APC / Fabriquée en fonte nodulaire de précision APC

REPUESTOS LLAVE HEAVY DUTY / HEAVY DUTY WRENCH SPARE PARTS / PIECES DE RECHANGE CLÉ HEAVY DUTY / HEAVY DUTY ROHRZANGE ERSATZTEILEN / RICAMBI CHIAVI HEAVY DUTY / COMPONENTES DE CHAVE HEAVY DUTY / ЗАПАСНЫЕ ЧАСТИ ДЛЯ КЛЮЧЕЙ ДЛЯ БОЛЬШИХ НАГРУЗОК

6"	85085	85083	85084	85082	
8"	81022	81015	81008	81001	Juego muelles / Spring Set / Jeu de ressorts
10"	81023	81016	81009	81002	
12"	81024	81017	81010	81003	
14"	81025	81018	81011	81004	Tuerca / Nut / Ecrou
18"	81026	81019	81012	81005	
24"	81027	81020	81013	81006	Mordaza inferior / Heel Jaw / Mâchoire inférieure
36"	81028	81021	81014	81007	
48"	81031	81030	81029	81000	
60"	81674	81672	81673	81671	Lengua / Hook Jaw / Bec

RAP

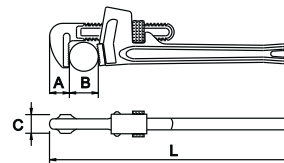

COD	L	A	B	C	Kg.		
61376	10"	20	1.1/2"	17	0,9	6	1

GGG-W-651-E, Type II Class A

# 13 HERRAMIENTA PARA TUBO / PIPE TOOLS / OUTILLAGE TUBE / ROHR WERKZEUGE / UTENSILI PER TUBI / FERRAMENTA PARA TUBOS / ТРУБНЫЙ ИНСТРУМЕНТ

LLAVE HEAVY DUTY CURVA / OFFSET HEAVY DUTY PIPE WRENCH / CLÉ SERRE-TUBES HEAVY DUTY COUDEE /  
BEKRÖPFTE ROHRZANGE / GIRATUBI MODELLO AMERICANO CURVO / CHAVE HEAVY DUTY INCLINADA / ИЗОГНУТЫЕ  
ТРУБНЫЕ КЛЮЧИ ДЛЯ БОЛЬШИХ НАГРУЗОК

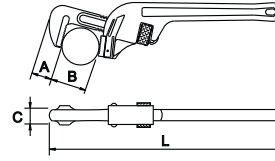

COD	L	A	B	C	Kg.		
61029	8"	16	1"	20	0,35		
61030	10"	20	1.1/2"	23	0,80	6	1
61031	12"	22	2"	26	1,30		
61032	14"	25	2"	29	1,54	5	
61033	18"	27	2.1/2"	33	2,30	3	
61034	24"	31	3"	35	4	1	

GGG-W-651-E, Type IV

PICO PATO / OFFSET PIPE WRENCH 90° / CLÉ SERRE-TUBE 90° / ROHRZANGE 90° / GIRATUBI 90° / BICO PATO /  
ИЗОГНУТЫЕ ТРУБНЫЕ КЛЮЧИ ДЛЯ БОЛЬШИХ НАГРУЗОК

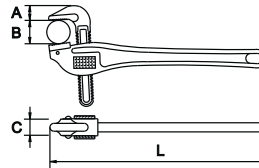

COD	L	A	B	C	Kg.		
61377	14"	25	2"	23	1,60	2	1
61378	18"	29	2.1/2"	26	2,70	1	

GGG-W-651-E, Type II Class A

LLAVE DE ALUMINIO / ALUMINIUM PIPE WRENCH / CLÉ SERRE-TUBES EN ALLIAGE D'ALUMINIUM / ALUMINIUM  
ROHRZANGE / GIRATUBI MODELLO AMERICANO IM ALLUMINIO / CHAVE ALUMINIO / АЛЮМИНИЕВЫЕ ТРУБНЫЕ КЛЮЧИ

TITALUM®

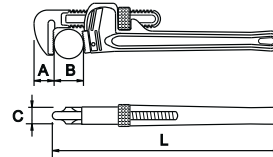

COD	L	A	B	C	Kg.		
61044	10"	20	1.1/2"	17	0,5	6	1
61023	12"	23	2"	20	0,8		
61024	14"	25	2"	23	0,9	3	
61025	18"	28	2.1/2"	26	1,6		
61026	24"	33	3"	29	2,5		
61027	36"	43	5"	33	5,0	1	
61028	48"	55	6"	35	8,1		

GGG-W-651-E, Type II Class C

PICO PATO DE ALUMINIO / ALUMINIUM OFFSET PIPE WRENCH 90° / CLÉ SERRE-TUBE 90° EN ALLIAGE  
D'ALUMINIUM / ROHRZANGE 90° ALUMINIUM / GIRATUBI 90° IM ALLUMINIO / BICO PATO ALUMINIO /  
АЛЮМИНИЕВЫЕ ИЗОГНУТЫЕ ТРУБНЫЕ КЛЮЧИ 90°

TITALUM®

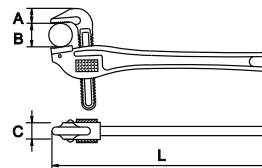

COD	L	A	B	C	Kg.		
61363	14"	25	2"	28	0,8	6	1
61364	18"	28	2.1/2"	39	1,2	2	
61365	24"	34	3"	42	2,2	1	

GGG-W-651-E, Type II Class C

# 13

## HERRAMIENTA PARA TUBO / PIPE TOOLS / OUTILLAGE TUBE / ROHR WERKZEUGE / UTENSILI PER TUBI / FERRAMENTA PARA TUBOS / ТРУБНЫЙ ИНСТРУМЕНТ

LLAVE PARA TUBO TIPO BLITZ / BLITZ TYPE PIPE WRENCH / CLÉ SERRE-TUBE TYPE BLITZ / BLITZ ROHRZANGE / GIRATUBI MODELLO BLITZ / CHAVE PARA TUBO MODELO BLITZ / ТРУБНЫЙ КЛЮЧ ТИП-BLITZ

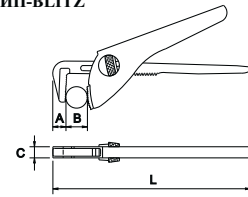

COD	L	A	B	C	Kg.		
61465	175mm	19	1"	12	0,3		
61466	225mm	20	1.1/2"	15	0,6	6	1
61467	275mm	21	2"	16	0,8		
61468	300mm	23	2.1/2"	17	1,0		
61469	350mm	24	3"		1,1		

LLAVE SPUD / SPUD PIPE WRENCH / CLÉ SPUD / VERSTELLBARE ROHRZANGE / GIRATUBI MODELLO SPUD / CHAVE PARA TUBO SPUD / ТРУБНЫЙ КЛЮЧ С ПАРАЛЛЕЛЬНЫМИ ГУБКАМИ

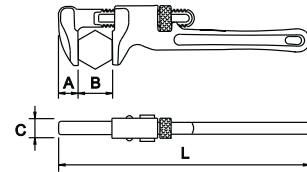

COD	L	A	B	C	Kg.		
61369	12"	24	2.5/8"	16	1,2	6	1

LLAVE HEXAGONAL / HEX PIPE WRENCH / CLÉ HEXAGONALE / SECHSKANT ROHRZANGE / GIRATUBI HEXAGONALE / CHAVE PARA TUBO HEXAGONAL / ТРУБНЫЙ КЛЮЧ ДЛЯ ШЕСТИГРАННИКОВ

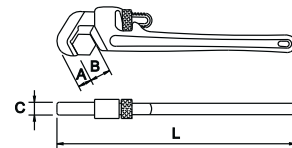

COD	L	A	B	C	Kg.		
61368	14.1/2"	29	5/8-1.1/4"	14	2,1	3	1

LLAVE HEXAGONAL CURVA / HEXAGONAL OFFSET PIPE WRENCH / CLÉ HEXAGONALE COUDEE / BEKRÖPFTE ROHRZANGE / GIRATUBI ESAGONALE CURVO / CHAVE HEXAGONAL INCLINADA / ИЗОГНУТЫЙ ТРУБНЫЙ КЛЮЧ ДЛЯ ШЕСТИГРАННИКОВ

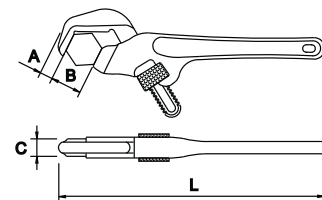

COD	L	A	B	C	Kg.		
61367	9.1/2"	14	1.1/8"-2.5/8"	9,5	0,7	6	1

# 13 HERRAMIENTA PARA TUBO / PIPE TOOLS / OUTILLAGE TUBE / ROHR WERKZEUGE / UTENSILI PER TUBI / FERRAMENTA PARA TUBOS / ТРУБНЫЙ ИНСТРУМЕНТ



LLAVES SUECAS / SWEDISH PIPE WRENCHES / CLÉS SERRE-TUBES SUEDOISES /  
ECKROHRZANGE / GIRATUBI MOD. SVEDESE / CHAVES PARA TUBOS SUECAS /  
ТРУБНЫЕ ШВЕДСКИЕ КЛЮЧИ

SERIE MASTER CR-V

LLAVE SUECA S 45° / SWEDISH PIPE WRENCH S 45° / CLÉ SERRE-TUBES SUEDOISE S 45° / ECKROHRZANGE S 45° / GIRATUBI MOD. SVEDESE S 45° / CHAVE SUECA S 45° / ТРУБНЫЙ ШВЕДСКИЙ КЛЮЧ S 45°

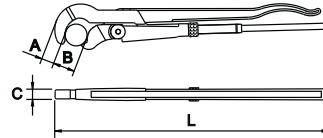

COD	A	B	C	L	Kg.		
61010	15	1/2"	8,8	230	0,4	4	1
61011	20	1"	13	330	0,8	6	1
61012	26	1.1/2"	14	420	1,4	4	-
61013	28	2"	16	550	2,4	2	-
61022	35	3"	19	650	4,2	2	-

Cr-V DIN 5234

LLAVE SUECA 45° / SWEDISH PIPE WRENCH 45° / CLÉ SERRE-TUBES SUEDOISE 45° / ECKROHRZANGE 45° /  
GIRATUBI MOD. SVEDESE 45° / CHAVE SUECA 45° / ТРУБНЫЙ ШВЕДСКИЙ КЛЮЧ 45°

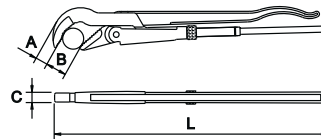

COD	A	B	C	L	Kg.		
61040	18	1/2"	8,8	230	0,4	4	1
61041	24	1"	13	330	0,7	6	1
61042	27	1.1/2"	14	450	1,4	4	-
61043	33	2"	16	550	2,3	2	-

Cr-V DIN 5234

LLAVE SUECA 90° / SWEDISH PIPE WRENCH 90° / CLÉ SERRE-TUBES SUEDOISE 90° / ECKROHRZANGE 90° /  
GIRATUBI MOD. SVEDESE 90° / CHAVE SUECA 90° / ТРУБНЫЙ ШВЕДСКИЙ КЛЮЧ 90°

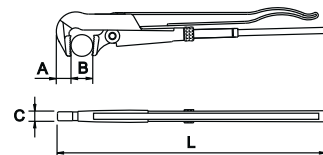

COD	A	B	C	L	Kg.		
61046	18	1"	15	320	0,7	6	1
61047	20	1.1/2"	18	430	1,3	4	-
61048	25	2"	20	550	2,3	2	-
61049	30	3"	20	600	3,0	2	-
61051	34	4"	31	750	5,3	1	-

Cr-V DIN 5234

LLAVE SUECA BOCAS DE PLÁSTICO / FITTINGS WRENCH / MACHOIRES EN PLASTIQUE / ECKROHRZANGE MIT  
KUNSTSTOFFBACKEN / CON GANASCE IN PLASTICA / CHAVE SUECA BOCAS DE PLASTICO /  
КЛЮЧ ДЛЯ ФАСОННЫХ ЧАСТЕЙ

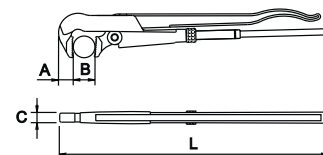

COD	A	B	C	L	Kg.		
61050	21	1"	9,5	310	0,8	6	64257

Cr-V DIN 5234



# 13

## HERRAMIENTA PARA TUBO / PIPE TOOLS / OUTILLAGE TUBE / ROHR WERKZEUGE / UTENSILI PER TUBI / FERRAMENTA PARA TUBOS / ТРУБНЫЙ ИНСТРУМЕНТ

LLAVE SUECA BOCAS RECTAS / SWEDISH PIPE WRENCH STRAIGHT JAWS / CLÉ SERRE-TUBES SUEDOISE / ESKROHRZANGE / GIRATUBI MOD. SUEDESE / CHAVE SUECA RECTA / ТРУБНЫЙ ШВЕДСКИЙ КЛЮЧ С ПРЯМЫМИ ГУБКАМИ

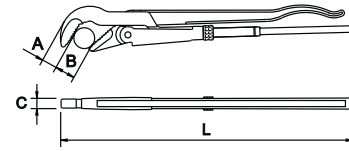

COD	A	B	C	L	Kg.		
60963	24	1"	13	320	0,7	6	1
60964	27	1.1/2"	14	420	1,4	4	-
60965	33	2"	16	550	2,3	2	-

Cr-V DIN 5234

LLAVE DE CADENA REVERSIBLE / REVERSIBLE CHAIN PIPE WRENCH / CLÉ À CHAÎNE REVERSIBLE / KETTENROHRZANGE / CHIAVE A CATENA REVERSIBILE / CHAVE CORRENTE REVERSIVEL / РЕВЕРСИВНЫЙ ЦЕПНОЙ КЛЮЧ

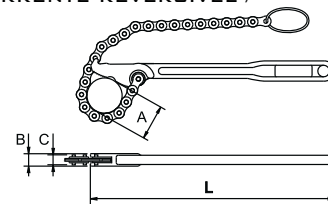

COD	A	B	C	L	Kg.		
61035	4"	19	19	300mm-12"	0,8	6	64038

LLAVE DE CADENA REVERSIBLE REFORZADA / HEAVY DUTY REVERSIBLE CHAIN PIPE WRENCH / CLÉ À CHAÎNE REVERSIBLE RENFORCÉE / VERSTÄRKT KETTENROHRZANGE / CHIAVE A CATENA REVERSIBILE RINFORZATA / CHAVE CORRENTE REVERSIVEL REFORÇADA / РЕВЕРСИВНЫЙ ЦЕПНОЙ КЛЮЧ ДЛЯ БОЛЬШИХ НАГРУЗОК

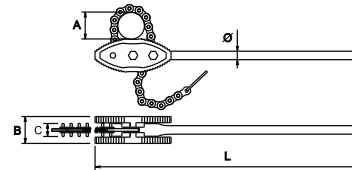

COD	A	B	C	L	Kg.		
61036	4"	65	36	900	5,5	1	64081
61037	6"			900	6,5		64082
61038	8"			1100	12		64083
61039	10"			1100	13		64084
61138	12"	70	36	1300	17		64128
61139	16"			1300	19		64129
62050	18"			1300	21		64906
62051	20"			1300	23		64907

LLAVE DE CORREA / STRAP WRENCH / CLÉ À SANGLE / GURTRÖHRZANGE / GIRATUBI A NASTRO / CHAVE DE CORREIA / РЕМЕШКОВЫЙ КЛЮЧ

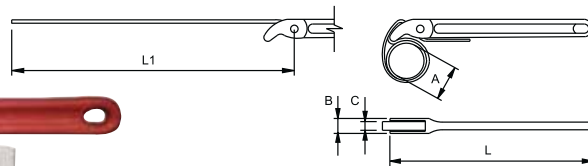

COD	A	B	C	L	L <sub>1</sub>	Kg.			
61480	3"	43	27	300mm-12"	450	0,3	6	1	64035
61481	8"			1000	64036				
61482	12"			1200	63960				



# 13 HERRAMIENTA PARA TUBO / PIPE TOOLS / OUTILLAGE TUBE / ROHR WERKZEUGE / UTENSILI PER TUBI / FERRAMENTA PARA TUBOS / ТРУБНЫЙ ИНСТРУМЕНТ

TERRAJAS AJUSTABLES / ADJUSTABLE THREADERS / FILIERES AJUSTABLES / VERSTELLBARE  
GEWINDESCHNEIDKLUPPE / FILIERA REGOLABILE / TARRACHAS AJUSTAVEIS / РЕГУЛИРУЕМАЯ РЕЗЬБОНАРЕЗКА

KIT

BSPT	COD	NPT		Kg.	
63160		63162	1/4"÷2"	10	1
63161		63163	1/2"÷2"	10	

PEINES / DIES / PEIGNES / SCHNEIDBACKEN / PETTINI / CAÇONETES /  
ГРЕБЕНКИ

BSPT	NPT		Kg.	
64338	64342	1/4"÷3/8"	0,4	1
64339	64343	1/2"÷3/4"	0,4	
64340	64344	1"÷1.1/4"	0,4	
64341	64345	1.1/2"÷2"	0,3	



KIT





BSPT	COD	NPT		Kg.	
63164		63166	1.1/2"÷4"	22	1
63165		63167	2.1/2"÷4"	21	

PEINES / DIES / PEIGNES / SCHNEIDBACKEN / PETTINI / CAÇONETES /  
ГРЕБЕНКИ





BSPT	NPT		Kg.	
64346	64349	1.1/2"÷2"	0,9	1
64347	64350	2.1/2"÷3"		
64348	64351	3.1/2"÷4"		



### CABEZAS / HEADS / TÊTES / SCHNEIDKÖPFE / TESTE / CAVÊÇAS / РЕЗЬБОНАРЕЗНЫЕ ГОЛОВКИ



BSPT	COD	NPT	BSPP		Kg.			
63001	63011	63011	63723	1/4"	0,6	1	1	
63002	63012	63012	63724	3/8"	0,6			
63003	63013	63013	63725	1/2"	0,6			
63004	63014	63014	63726	3/4"	0,5			
63005	63015	63015	63727	1"	0,8			
63006	63016	63016	63728	1.1/4"	0,9			



BSPT	COD	NPT	BSPP		Kg.			
63007	-	-	-	1.1/4"	1,5	1	-	
63008	63018	63018	63730	1.1/2"	1,9			
63009	63019	63019	63731	2"	1,9			



SERIE PESADA / HEAVY DUTY / SÉRIE LOURDE

### PEINES / DIES / PEIGNES / SCHNEIDBACKEN / PETTINI / CAÇONETES / ГРЕБЕНКИ

BSPT	COD	NPT	BSPP		gr.		
63040	63050	63050	64487	1/4"	70	1	
63041	63051	63051	64488	3/8"			
63042	63052	63052	64489	1/2"			
63043	63053	63053	64490	3/4"			
63044	63054	63054	64491	1"			
63045	63055	63055	64492	1.1/4"			
63046	63056	63056	64493	1.1/2"	230		
63047	63057	63057	64494	2"			



### CARRACAS / RATCHET / CLIQUETS / RATSCHENHEBEL / CRICCO DI MANOVRA / ROQUETES / ТРЕЩЕТКИ

COD		Kg.		
63000	1/4" ÷ 1.1/4"	1,5	1	1
63010	1.1/4" ÷ 2"	3,0		
63010+80833	1/4" ÷ 2"	3,15		



### REDUCTOR / ADAPTOR / ADAPTATEUR / ADAPTER / RIDUTTORE / REDUTOR / АДАПТЕР

COD	CAP	gr.		
80833	1/4" ÷ 1.1/4"	15 gr	1	1



### ACEITE DE CORTE / CUTTING OIL / HUILE DE COUPE / GEWINDESCHNEIDMITTEL / OLIO DA TAGLIO / OLEO DE CORTE / РЕЗЬБОНАРЕЗНОЕ МАСЛО

COD	CAP ml.	
64007	60	1



# 13 HERRAMIENTA PARA TUBO / PIPE TOOLS / OUTILLAGE TUBE / ROHR WERKZEUGE / UTENSILI PER TUBI / FERRAMENTA PARA TUBOS / ТРУБНЫЙ ИНСТРУМЕНТ

TERRAJA DE CABEZAS INTERCAMBIABLES / DROP HEADS THREADERS / FILIERES A TÊTES  
INTERCHANGEABLES / SET GEWINDESCHNEIDKLUPPEN / FILIERE PER TUBI / TARRACHAS DE CABEÇAS  
INTERMUTAVEIS / РЕЗЬБОНАРЕЗНОЙ НАБОР

BSPT	COD NPT	BSPP					
63020	63026	63032	1/4"÷1.1/4"	6	63000	51000	7,5
63021	63027	63033	3/8"÷1.1/4"	5			7,0
63022	63028	63034	1/2"÷1.1/4"	4			6,5
63023	63029	63035	1/4"÷1"	5			6,5
63024	63030	63048	3/8"÷1"	4			6,0
63025	63031	63049	1/2"÷1"	3			5,5



BSPT	COD NPT	BSPP					
63036	63038	63058	1.1/4"÷2"	3	63010	51001	9,8
63037	63039	63059	1.1/2"÷2"	2			8,40



BSPT	COD NPT	BSPP						
63134	63139	63072	1/4"÷2"	8	80833	63010	50002	14
63133	63138	63073	3/8"÷2"	7				14
63132	63137	63074	1/2"÷2"	6				12



### MASTERKIT - 1

COD	1/2" - 1"	14°	14°	1"	10"	2"	Kg.
69000		●					10
69001	●		●				10
69002				●			9,5
69021	●		●		●	●	10
69787		●					10
69788			●				10
69789				●			9,5



### MASTERKIT - 2

COD	1/2 - 2	14°	14°	1"	10"	2"	Kg.
69050		●					16
69051	●		●				17
69052				●			16
69072	●		●		●	●	17
69790		●					16
69791			●				17
69792				●			16



### TERRAJAS TIPO REED / REED TYPE THREADERS / FILIERES À COUSSINETS CARRES / REED-GEWINDESCHNEIDKLUPPE / FILIERA TIPO REED / TARRACHAS CAÇONETE QUADRADO / РЕЗЬБОНАРЕЗНОЙ НАБОР REED

COD		Kg.
BSPT	NPT	
69160	69163	1/4"±1"
69161	69164	3/8"±1"
69162	69165	1/2"±1"



### COJINETES / DIES / COUSSINETS / NÄHKISSEN / CUSCINETTI / CAÇONETES / ГРЕБЕНКИ

COD		gr.	Kg.
BSPT	NPT		
64040	64046	1/4"	260
64041	64047	3/8"	210
64042	64048	1/2"	220
64043	64049	3/4"	210
64044	64050	1"	240



### CARRACAS / RATCHET / CLIQUETS / RATSCHENHEBEL / CRICCO DI MANDURA / ROQUETES / ТРЕЩЕТКИ

COD	Kg.
63075	3,0



# 13 HERRAMIENTA PARA TUBO / PIPE TOOLS / OUTILLAGE TUBE / ROHR WERKZEUGE / UTENSILI PER TUBI / FERRAMENTA PARA TUBOS / ТРУБНЫЙ ИНСТРУМЕНТ

TERRAJAS TIPO ARMSTRONG / ARMSTRONG TYPE THREADERS / FILIERES MOD. ARMSTRONG / SET  
GEWINDESCHNEIDKLUPPEN TYP ARMSTRONG / FILIERA TIPO ARMSTRONG / TARRACHAS TIPO ARMSTRONG /  
РЕЗЬБОНАРЕЗНОЙ НАБОР ARMSTRONG

BSPT	COD	NPT				
69130	69145		1/4"÷1.1/4"	6	63069	5,5
69131	69146		3/8"÷1.1/4"	5		5,5
69132	69147		1/2"÷1.1/4"	4		5,0
69133	69148		1/4"÷1"	5		5,5
69134	69149		3/8"÷1"	4		5,0
69135	69150		1/2"÷1"	3		5,0



BSPT	COD	NPT				
69136	69151		1/2"÷2"	6	63070	7,5
69137	69152		3/4"÷2"	5		8,5
69138	69153		1"÷2"	4		8,0
69139	69154		1.1/4"÷2"	3		7,5

COJINETES / DIES / COUSSINETS / NÄHKISSEN / CUSCINETTI / CAÇONETES / ГРЕБЕНКИ

BSPT	COD	NPT			
64010	64022		1/4"	260	1
64011	64023		3/8"	250	
64012	64024		1/2"	230	
64013	64025		3/4"	230	
64014	64026		1"	210	
64015	64027		1.1/4"	175	

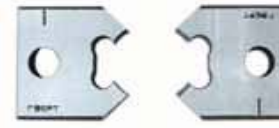

BSPT	COD	NPT			
64016	64028		1/2"	550	1
64017	64029		3/4"	550	
64018	64030		1"	500	
64019	64031		1.1/4"	450	
64020	64032		1.1/2"	400	
64021	64033		2"	310	







CARRACAS / RATCHET / CLIQUETS / RATSCHENHEBEL / GRICCO DI MANOURA / ROQUETES / ТРЕЩЕТКИ

COD			
63069	1/4"÷1.1/4"	3,0	1
63070	1/2"÷2"	4,0	1







CORTATUBOS DE ACERO / STEEL PIPE CUTTER / COUPE-TUBES ACIER / ROHRABSCHNEIDER / TAGLIATUBI PER FERRO / CORTA TUBOS AÇO / ТРУБОРЕЗ ДЛЯ СТАЛЬНЫХ ТРУБ





ACERO / STEEL / ACIER

COD		 Kg.		
63171	1/8"÷1.1/4"	1,1	2	63103
63172	1/8"÷2"	2,5	1	63101





ACERO INOXIDABLE / STAINLESS STEEL / ACIER INOXYDABLE

COD		 Kg.		
63098	1/8"÷1.1/4"	1,1	2	63090
63099	1/8"÷2"	2,5	1	63091

ACERO / STEEL / ACIER

COD		 Kg.		
63366	1/8"÷2"	3,2	1	63101
63193	1"÷3"	5,0	1	63195





ACERO INOXIDABLE / STAINLESS STEEL / ACIER INOXYDABLE

COD		 Kg.		
63378	1/8"÷2"	3,2	1	63091
63194	1"÷3"	5,0	1	63092

ACERO / STEEL / ACIER





COD		 Kg.		
63175	2"÷4"	8,0	1	63185

ACERO INOXIDABLE / STAINLESS STEEL / ACIER INOXYDABLE





COD		 Kg.		
63177	2"÷4"	8,0	1	63186

CORTATUBOS ARTICULADO / HINGED PIPE CUTTER / COUPE TUBES ARTICULÉ / UNIVERSAL ROHRABSCHNEIDER / TAGLIATUBI ARTICOLATO / CORTA TUBOS ARTICULADO / ТРУБОРЕЗ С ХОМУТНОЙ ЗАЩЕЛКОЙ





ACERO / STEEL / ACIER

COD		 Kg.		
63355	2"÷4"	6,0	1	64173
63356	4"÷6"	9,0		64174
63357	6"÷8"	11		64175
63358	8"÷12"	16		64176

ACERO INOXIDABLE / STAINLESS STEEL / ACIER INOXYDABLE

COD		 Kg.		
63359	2"÷4"	6,0	1	64196
63360	4"÷6"	9,0		64197
63361	6"÷8"	11		64198
63362	8"÷12"	16		64199

HIERRO DÚCTIL Y FUNDICIÓN / CAST AND DUCTILE IRON / FER MALLÉABLE ET FONTE

COD		 Kg.		
63772	2"÷4"	6,0	1	64654
63773	4"÷6"	9,0		64655
63774	6"÷8"	11		64655
63775	8"÷12"	16		64655

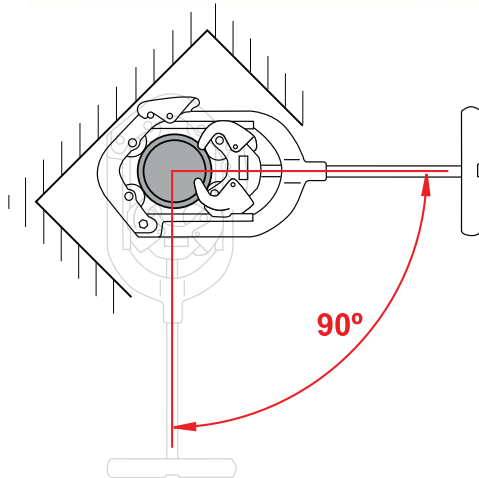

# 13 HERRAMIENTA PARA TUBO / PIPE TOOLS / OUTILLAGE TUBE / ROHR WERKZEUGE / UTENSILI PER TUBI / FERRAMENTA PARA TUBOS / ТРУБНЫЙ ИНСТРУМЕНТ

CORTATUBOS / TUBE CUTTER / COUPE-TUBES / KUPFER ROHRABSCHNEIDER /  
TAGLIATUBI / CORTA TUBOS / ТРУБОРЕЗ

SERIE INOX / STAINLESS STEEL / INOX / EDELSTAHL / ACCIAIO INOX / AÇD INOXIDAVEL /  
НЕРЖАВЕЮЩАЯ СТАЛЬ

## MINI

COD	MAT.	O.D.	gr.				
63190	INOX	3-16	90	20	1	63089	20
63096		3-22	120			63113	



## MINI 30

COD	MAT.	O.D.	gr.				
63169	INOX	3-30	210	10	1	63087	20



## CLASSIC 32

COD	MAT.	O.D.	gr.				
63094	INOX	3-32	300	1	1	63113	20



## TELESCOPIC 32

COD	MAT.	O.D.	gr.				
63118	INOX	6-32	290	1	1	63113	20



## UNIQUE

COD	MAT.	O.D.	gr.				
63078	INOX	6-35	480	1	1	63114	10
63121		6-42	550	8			
63188		6-45	600	1			



## AUTOMATIC 50

COD	MAT.	O.D.	gr.				
63364	INOX	6-50	450	1	1	63721	10



## AUTOMATIC 67

COD	MAT.	O.D.	gr.				
63126	INOX	6-67	750	1	1	63114	10



## KIT 3

COD	
69548	63096 - 63094 - 63121



EXPOSITOR / DISPLAY / PRESENTOIR / STÄNDER / ESPOSITORE / DISPLAY STAND / СТЕНДЫ  
20 PCS

COD	UN.	O.D.
55568	4	63094
		63118
		63078
		63121
		63188







**NEW**



TORNILLO DE BANCO PARA TUBOS / PIPE VICE / ÉTAU À CHARNIÈRE / ROHRSCHRAUBSTOCK / MORSA PER TUBI / TORNO PARA TUBOS / ВЕРСТАЧНЫЕ ТРУБНЫЕ ТИСКИ

COD	INCH	mm	Kg.	
61202	1/8"÷2"	10-60	4,0	1
61204	1/8"÷3"	10-89	8,0	
61205	1/8"÷4"	10-114	12	



COD	2"	COD	3"	COD	4"
64260		64352		64258	
64261		64353		64259	

TORNILLO DE BANCO PARA TUBOS PORTÁTIL / PORTABLE PIPE VICE / ÉTAU À TUBE PORTABLE / TRAGGBARE ROHRSCHRAUBSTOCK / MORSA DA BANCO PER TUBI PORTATILI / TORNO DE BANCADA PARA TUBO PORTÁTIL / ТРУБНЫЕ ТИСКИ СО СТРУБЦИНОЙ

COD	INCH	mm	Kg.	
61199	1/8"÷2"	10-60	5,5	1



MORDAZA DE CADENA / CHAIN VICE / ÉTAU À CHAÎNE / KETTENROHRSCHRAUBSTOCK / MORSA A CATENA / TORNOS DE CORRENTE / ЦЕПНЫЕ ТИСКИ

COD	INCH	Kg.	
61206	1/8"÷6"	12	1



TRISTAND

COD	INCH	mm	Kg.	
61200	1/8"÷6"	10-170	21	1

Con mordaza de cadena / With chain vice / Avec étau à chaîne



MESA DE TRABAJO / WORK BENCH / TABLE DE MONTEUR / ARBEITSTISCH / BANCHI DA LAVORO / MESAS DE TRABALHO / РАБОЧИЙ СТОЛ

COD		W	L	H	Kg.
61197	A	710	450	825	18
61198	B	1005	505	845	22
61196		1205	705	845	30





# 13 HERRAMIENTA PARA TUBO / PIPE TOOLS / OUTILLAGE TUBE / ROHR WERKZEUGE / UTENSILI PER TUBI / FERRAMENTA PARA TUBOS / ТРУБНЫЙ ИНСТРУМЕНТ



CORTATUBOS BISELADOR ELÉCTRICO / ELECTRIC BEVELLING MACHINE / COUPE-TUBES  
CHANFREINEUR ÉLECTRIQUE / ELEKTRISCHE ANFAS-MASCHINE / TAGLIATUBI SMUSSATO-  
RE ELETTRICO / CORTA TUBOS BISELADOR ELÉCTRICO / МАШИНА ДЛЯ СНЯТИЯ ФАСКИ



COD	Ø	O.D.	V	R.P.M	Kg.	
55815	3/8"-2.1/2"	Ø10-80 mm	230V(50-60Hz)	≤ 25mm	24	
55824			110V(50-60Hz)			
55816	2.1/2"-5"	Ø65-150 mm	230V(50-60Hz)		16	32
55825			110V(50-60Hz)			
55817	6"-10"	Ø150-300 mm	230V(50-60Hz)		13	65
55826			110V(50-60Hz)			
55818	12"-16"	Ø300-450 mm	230V(50-60Hz)		10	90
55827			110V(50-60Hz)			
55819	18"-22"	Ø450-600 mm	230V(50-60Hz)		8	126
55828			110V(50-60Hz)			
55820	24"-28"	Ø600-750 mm	230V(50-60Hz)		7	209
55829			110V(50-60Hz)			
55821	30"-34"	Ø750-900 mm	230V(50-60Hz)		6	321
55830			110V(50-60Hz)			
55822	36"-40"	Ø900-1050 mm	230V(50-60Hz)		5	468
55831			110V(50-60Hz)			
55823	46"-50"	Ø1150-1300 mm	230V(50-60Hz)	1186		
55832			110V(50-60Hz)			

### Especificaciones técnicas / Technical specification / Détails techniques

Corriente / Current / Courant	6A
Potencia / Power / Puissance	0,5-2,5KW

**CORTATUBOS PROPULSADO / POWER PIPE CUTTER / COUPE TUBE ELECTRIQUE / ROHRTRENNGERÄT / TAGLIATUBI ALIMENTATO / CORTA TUBOS ELECTRO-HIDRÁULICO / ТРУБОРЕЗ С ЭЛЕКТРОПРИВОДОМ**

**KIT CORTAMATIC - 12**

SET CON MASTERMATIC-2 / SET INCLUDING MASTERMATIC-2 / SET INCLUS MASTERMATIC-2 / SET INCLUSIVE MASTERMATIC-2 / ASSORTIMENTO CON MASTERMATIC 2 / CONJUNTO COM MASTERMATIC 2 / НАБОР С MASTERMATIC-2

COD	V	CAP	Kg.
60000	230V(50-60Hz)	2.1/2"+12"	75
60001	110V(50-60Hz)		



**CORTAMATIC - 12**

COD	CAP	Kg.
60002	2.1/2"+12"	65

**Especificaciones técnicas / Technical specification / Détails techniques**

Capacidad 2.1/2"-12" (Schedule 10/40) / Capacity 2.1/2"-12" (Schedule 10/40) / Capacité 2.1/2"-12" (Schedule 10/40)

Poderoso cilindro hidráulico de 10 toneladas / Powerful 10-ton hydraulic cylinder / Cylindre hydraulique puissant de 10 tonnes

Cortes perfectos en escuadra, sin chispas ni polvo / Perfect square cuts, without dust or sparks / Coupes parfaites à angles droits, sans étincelles ni poussière

Incluidos 2 soportes para tubo / 2 pipe stands included / 2 supports pour tube inclus



**REPUESTOS / SPARE PARTS / RECHANGES / ERSATZTEILE / ACCESORI / ACESSORIOS / ЗАПАСНЫЕ ЧАСТИ**



60003



60017



60018

**TORNILLO DE BANCO PARALELO CON MORDAZAS PARA TUBO / PARALLEL PIPE VICE WITH PIPE JAWS / ETALU À MORS PARALLELES AVEC SERRE TUBE / PARALLELSCHRAUBSTOCK MIT ROHRSPANNBACKEN / MORSA PARALLELA CON GANASCE PER TUBI / TORNO PARALELO CON MORDAÇAS PARA TUBO / СЛЕСАРНЫЕ ТИСКИ С ТРУБНЫМИ ГУБКАМИ**

**FIJO / FIXED / FIXE / FESTE-AUSFÜHRUNG / BASE FISSA / FIXO / ФИКСИРОВАННЫЙ**

COD	INCH	N	Kg.
69630	4"	110	15.000
69631	5"	150	25.000
69632	6"	225	35.000
69633	7"		50.000

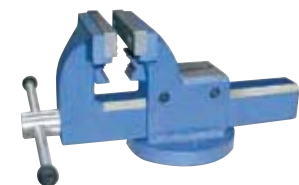

**ACERO FORJADO / FORGED STEEL / ACIER FORGÉ**

**GIRATORIO / SWIVEL / TOURNANT / DREHBARE / MORSA GIREVOLE / BASE GIRATORIA / ПОВОРОТНОЕ**

COD	INCH	N	Kg.
69634	4"	110	15.000
69635	5"	150	25.000
69636	6"	225	35.000
69637	7"		50.000

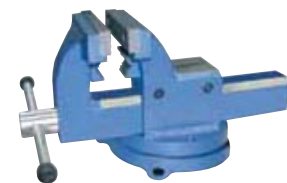

**ACERO FORJADO / FORGED STEEL / ACIER FORGÉ**

COD	Kg.
81036	0,6
81037	1,6
81038	2,9
81039	2,9



COD	Kg.
80079	4"
80080	5"
80081	6"
80082	7"



# 13 HERRAMIENTA PARA TUBO / PIPE TOOLS / OUTILLAGE TUBE / ROHR WERKZEUGE / UTENSILI PER TUBI / FERRAMENTA PARA TUBOS / ТРУБНЫЙ ИНСТРУМЕНТ

TORNILLO DE BANCO PARALELO / PARALLEL BENCH VICE / ETAU À MORS PARALLELES /  
PARALLELSCHRAUBSTÜCKE / MORSA DA BANCO PARALLELA / TORNO DE BANCADA PARALELO / ТИСКИ  
FIJO / FIXED / FIXE / FESTE-AUSFÜHRUNG / BASE FISSA / FIXO / ФИКСИРОВАННЫЙ

COD			N	Kg.	
69592	4"	110	15.000	9,5	1
69593	5"	150	25.000	13	
69594	6"	220	35.000	22	
69595	8"	220	50.000	29	

ACERO FUNDIDO / CAST STEEL / FONTE D'ACIER



GIRATORIO / SWIVEL / TOURNANT / DREHBARE / MORSA GIREVOLE / BASE GIRATORIA / ПОВОРОТНОЕ

COD			N	Kg.	
69596	4"	110	15.000	11	1
69597	5"	150	25.000	15	
69598	6"	220	35.000	24	
69599	8"	220	50.000	31	

ACERO FUNDIDO / CAST STEEL / FONTE D'ACIER



COD		
81961	4"	1,4
81962	5"	1,9
81963	6"	2,0
81964	8"	2,0



COD	
80749	4"
80750	5"
80751	6"
80752	8"



TORNILLO DE BANCO PARALELO AJUSTE RÁPIDO / QUICK ACTION PARALLEL BENCH VICE / ETAU PARALLELE  
AVEC REGLAGE RAPIDE / SCHNELLVERSTELLBARE PARALLELSCHRAUBSTOCK / MORSA DA BANCO AZIONE  
RAPIDA / TORNO DE BANCADA PARALELO AJUSTE RÁPIDO / ТИСКИ С БЫСТРЫМ ЗАЖИМОМ



ACCIÓN RÁPIDA  
QUICK ACTION  
REGLAGE RAPIDE

FIJO / FIXED / FIXE / FESTE-AUSFÜHRUNG / BASE FISSA / FIXO / ФИКСИРОВАННЫЙ

COD			N	Kg.	
69724	4"	110	15.000	9,4	1
69725	5"	150	25.000	13	

ACERO FUNDIDO / CAST STEEL / FONTE D'ACIER



ACCIÓN RÁPIDA / QUICK ACTION / REGLAGE RAPIDE

GIRATORIO / SWIVEL / TOURNANT / DREHBARE / MORSA GIREVOLE / BASE GIRATORIA / ПОВОРОТНОЕ

COD			N	Kg.	
69709	4"	110	15.000	11	1
69710	5"	150	25.000	15	

ACERO FUNDIDO / CAST STEEL / FONTE D'ACIER



ACCIÓN RÁPIDA / QUICK ACTION / REGLAGE RAPIDE

COD		
82751	4"	1,4
82752	5"	1,9









COD	
80761	4"
80762	5"



CURVATUBOS HIDRÁULICO / HYDRAULIC PIPE BENDER / CINTREUSE HYDRAULIQUE / HYDRAULIK-ROHRBIEGER / CURVATUBI IDRAULICO / CURVADORAS HYDRAULICAS PARA TUBOS / ГИДРАВЛИЧЕСКИЙ ТРУБОГИБ

### CURVAMATIC

	COD		TONS.		
CURVAMATIC 2	60015	1/4"×2"	10	75	1
CURVAMATIC 3	60016	1/4"×3"	13	110	









COD				
64190	1/4", 3/8", 1/2"	86	0,8	1
64191	3/4"	108	1,1	
64192	1"	135	1,1	
64193	1.1/4"	170	2,4	
64194	1.1/2"	193	3,0	
64195	2"	242	5,0	
*64231	2.1/2"	303	16	
*64232	3"	358	22	



CE \*G12



\*Sólo para Curvatic 3 \*Only for Curvatic 3 \*Seulement pour Curvatic 3

### TUBO API NORM API NORM PIPE TUBE API NORM

								
	SCHEDULE 10		SCHEDULE 40		SCHEDULE 80		SCHEDULE 160	
1/4"	0.410	0.065	0.364	0.088	0.302	0.119	no standardized	
3/8"	0.545	0.083	0.493	0.091	0.423	0.126		
1/2"	0.674		0.622	0.190	0.546	0.147	0.466	0.187
3/4"	0.884	0.109	0.824	0.113	0.742	0.154	0.614	0.218
1"	1.097		1.049	0.133	0.957	0.179	0.815	0.250
1.1/4"	1.442		1.380	0.140	1.278	0.191	1.160	
1.1/2"	1.682		1.610	0.145	1.500	0.200	1.338	0.281
2"	2.157		2.067	0.154	1.939	0.218	1.689	0.343
* 2.1/2"	2.63	0.12	2.47	0.203	-	-	-	-
* 3"	3.26		3.07	0.216				

\*Sólo para Curvatic 3 \*Only for Curvatic 3 \*Seulement pour Curvatic 3

### TUBO DE ACERO DIN-2440 DIN-2440 STEEL PIPE TUBE D'ACIER DIN-2440

		
1/4"	13mm	2.35mm
3/8"	17mm	
1/2"	21mm	2.65mm
3/4"	27mm	
1"	34mm	3.25mm
1.1/4"	42mm	
1.1/2"	48mm	
2"	60mm	3.65mm
* 2.1/2"	76mm	
* 3"	89mm	

\*Sólo para Curvatic 3 \*Only for Curvatic 3 \*Seulement pour Curvatic 3

Su especial e innovador sistema de válvula 2-VELO permite de forma automática una rápida aproximación así como un suave doblado sin necesidad de cambiar de pistón.

The special and innovative 2-VELO valve system enables fast pre-loading as well as a soft bending without any need to change pistons.

Son système spécial et innovateur de clapet 2-VELO permet un réglage automatique et progressif, sans avoir besoin de changer de piston.

\*G12: GARANTIA 12 MESES / 12 MONTHS OF WARRANTY / 12 MOIS DE GARANTIE / 12 MONATEN GARANTIE / 12 MAANDEN GARANTIE / 12 MESI DI GARANZIA

# 13 HERRAMIENTA PARA TUBO / PIPE TOOLS / OUTILLAGE TUBE / ROHR WERKZEUGE / UTENSILI PER TUBI / FERRAMENTA PARA TUBOS / ТРУБНЫЙ ИНСТРУМЕНТ

CURVADORA ELECTROHIDRÁULICA / ELECTROHYDRAULIC PIPE BENDER / CINTREUSE ÉLECTROHYDRAULIQUE /  
ELEKTRO-HYDRAULISCHE ROHRBIEGEMASCHINE / CURVATUBI ELETTRICO-IDRAULICA / CURVADORA ELECTRO-  
HIDRÁULICA / ГИДРАВЛИЧЕСКИЙ ЗАГИБОЧНЫЙ СТАНОК

**INOX / ACERO Hasta 4,5 mm**  
**STAINLESS STEEL / STEEL Up to 4,5 mm**  
**INOXIDABLE / ACIER jusqu'à 4,5 mm**

COD		TONS.	V		
60090	3/8"+1.1/2"	9	230V(50-60Hz)	150	1
60091			110V(50-60Hz)		



A	COD	B			
64890	64897	3/8"	4	1	
64891	64898	1/2"			
64892	64899	3/4"	4,5		
64893	64900	1"	4,7		
64894	64901	1.1/4"	8,5		
64895	64902	1.1/2"	14		



COD	W	V		
60094	750	230V(50-60Hz)	30	1
60095		110V(50-60Hz)		



### BOMBAS DE COMPROBACIÓN / TESTING PUMPS / POMPES D'EPREUVE / PRÜFPUMPE / POMPE PROVA IMPIANTI / BOMBAS DE COMPROVAÇÃO / ОПРЕССОВЩИК ГИДРАВЛИЧЕСКИЙ

COD	Vol. l.	MAX PSI	1/2"	Kg.	
60005	12	60=860Psi	1/2"	7,7	1
60009		100=1440Psi			



COD	Vol. l.	MAX PSI	1/2"	Kg.	
60011	12	60=860Psi	1/2"	7,7	1
60012		100=1440Psi			

ACERO INOXIDABLE / STAINLESS STEEL / ACIER INOXIDABLE / EDELSTAHL  
ACCIAIO INOX / AÇO INOXIDAVEL / НЕРЖАВЕЮЩАЯ СТАЛЬ



COD	Vol. l.	MAX PSI	1/2"	Kg.	
60006	12	60=860Psi	1/2"	9,0	1
60010		100=1440Psi			



#### Especificaciones técnicas / Technical specification / Détails techniques

Sistema de ajuste de presión rápido por medio de una sola válvula / Quick pressure adjust system with just one valve / Système rapide de réglage de la pression au moyen d'une seule valvule	●
Máxima estabilidad / Maximum stability / Stabilité maximale	●
Capacidad 12 l. / Capacity 12 l. / Capacité 12 l.	●
Manómetro de fácil lectura / Easy-reading manometer / Manomètre à lecture facile	●
Incluye manguera de presión / Pressure hose included / Tuyau de pression inclus	●
Uso cómodo / Comfortable use / Utilisation pratique	●

#### MASTERPUMP

ELÉCTRICA / ELECTRIC / ELECTRIQUE / ELEKTRISCH / ELETTRICA / ELÉTRICO / ЭЛЕКТРИЧЕСКИЙ

COD	CAP.	W	V	MAX PSI	1/2"	Kg.	
60223	7L/min	1750	230V(50-60Hz)	60=860Psi	1/2"	15	1
60225			110V(50-60Hz)				



#### SERIE CLASSIC

ELÉCTRICA / ELECTRIC / ELECTRIQUE / ELEKTRISCH / ELETTRICA / ELÉTRICO / ЭЛЕКТРИЧЕСКИЙ

COD	CAP.	W	V	MAX PSI	1/4"	Kg.	
60266	3L/min	250	230V(50-60Hz)	60=860Psi	1/4"	11	1
60267			110V(50-60Hz)				



\*G12: GARANTIA 12 MESES / 12 MONTHS OF WARRANTY / 12 MOIS DE GARANTIE / 12 MONATEN GARANTIE / 12 MAANDEN GARANTIE / 12 MESI DI GARANZIA

# INOX



***HERRAMIENTA PARA INOX / STAINLESS STEEL TOOLS / OUTIL POUR INOX /  
EDELSTAHL-WERKZEUGE / UTENSILI PER ACCIAIO INOX / FERRAMENTA PARA INOX /  
ИНСТРУМЕНТЫ ИЗ НЕРЖАВЕЮЩЕЙ СТАЛИ***

## HERRAMIENTA PARA INOX STAINLESS STEEL TOOLS OUTIL POUR INOX



**Medalla de Oro**, Salón Internacional de la Invención, París 2004  
**Gold Medal**, International Inventors Competition, Paris 2004  
**Medaille d'Or**, Salon International de L'Invention, Paris 2004

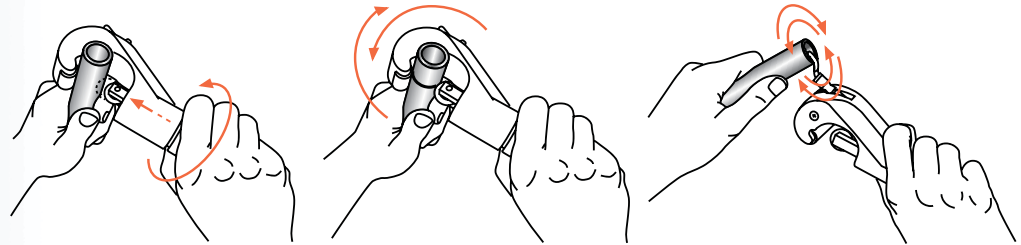

**1.** Acción rápida y suave gracias a su mecanizado de precisión.  
Precision machining provides the quickest and smoothest action.  
Action rapide et douce, grâce à son usinage très précis.

**2.** Extremadamente robusto, compacto y fácil de usar.  
Extremely robust, compact and easy to use.  
Très robuste, compact et aisé à utiliser.

**3.** Escala graduada marcada en láser para facilitar el posicionamiento.  
Laser marked graduated scale to facilitate working action.  
Echelle graduée, marquée au laser, pour faciliter le positionnement.

**4.** Cuchilla de repuesto incluida en el pomo.  
Extra cutting wheel at the knob.  
Molette de rechange, incluse dans le manche.

**5.** Especialmente diseñado para corte de tubos de acero inoxidable.  
Specially designed for cutting stainless steel pipes.  
Spécialement conçu pour couper les tubes en acier inoxydable.

**6.** Escariador extraíble puede trabajar montado en el cortatubos o de forma independiente.  
Extractable reamer can work assembled in the tubing cutter or independently.  
L'alésoir extractif peut travailler assemblé au coupe-tubes ou de manière indépendante.

**7.** Rodillos sin ranura fabricados en acero inoxidable para evitar contaminaciones.  
Stainless steel Rollers to avoid contamination, without groove.  
Rouleaux sans rainure fabriqués en acier inoxydable pour éviter la pollution.

**8.** Cuchilla HSS de larga duración para corte preciso y rápido.  
Long lasting HSS cutting Wheel for accurate and fast cutting.  
Lame HSS de longue durée pour coupure précise et rapide.





### CORTATUBOS / TUBE CUTTER / COUPE-TUBES / KUPFER ROHRABSCHNEIDER / TAGLIATUBI / CORTA TUBOS / ТРУБОРЕЗ

#### MINI

COD	MAT.	O.D.	gr.				
63190	INOX	3-16	90	20	1	63089	20
63096		3-22	120				

#### MINI 30

COD	MAT.	O.D.	gr.				
63169	INOX	3-30	210	10	1	63087	20

#### CLASSIC 32

COD	MAT.	O.D.	gr.				
63094	INOX	3-32	300	1	1	63113	20

#### TELESCOPIC 32

COD	MAT.	O.D.	gr.				
63118	INOX	6-32	290	1	1	63113	20

#### UNIQUE

COD	MAT.	O.D.	gr.				
63078	INOX	6-35	480	1	1	63114	10
63121		6-42	550	8			
63188		6-45	600	1			

#### AUTOMATIC 50

COD	MAT.	O.D.	gr.				
63364	INOX	6-50	450	1	1	63721	10

#### AUTOMATIC 67

COD	MAT.	O.D.	gr.				
63126	INOX	6-67	750	1	1	63114	10

#### KIT 3 PCS.

COD	
69548	63096 - 63094 - 63121

### EXPOSITOR / DISPLAY / PRÉSENTOIR / DISPLAY / ESPOSITORE / DISPLAY STAND / СТЕНДЫ

COD	UN.	O.D.
55568	4	63094
		63118
		63078
		63121
		63188

**NEW**







### CORTATUBOS INOX / STAINLESS STEEL PIPE CUTTER / COUPE-TUBES INOX / EDELSTAHL ROHRABSCHNEIDER / TAGLIATUBI PER ACCIAIO INOX / CORTA TUBOS INOX / ТРУБОРЕЗ ДЛЯ ТРУБ ИЗ НЕРЖАВЕЮЩЕЙ СТАЛИ





COD		Kg.		
63098	1/8"±1.1/4"	1,1	2	63090
63099	1/8"±2"	2,5	1	63091



## HERRAMIENTA PARA INOX / STAINLESS STEEL TOOLS / OUTIL POUR INOX / EDELSTAHL-WERKZEUGE / UTENSILI PER ACCIAIO INOX / FERRAMENTA PARA INOX / ИНСТРУМЕНТЫ ИЗ НЕРЖАВЕЮЩЕЙ СТАЛИ

CORTATUBOS INOX / STAINLESS STEEL PIPE CUTTER / COUPE-TUBES INOX / EDELSTAHL ROHRABSCHNEIDER / TAGLIATUBI PER ACCIAIO INOX / CORTA TUBOS INOX / ТРУБОРЕЗ ДЛЯ ТРУБ ИЗ НЕРЖАВЕЮЩЕЙ СТАЛИ





COD		 Kg.		
63378	1/8"÷2"	3,2	1	63091
63194	1"÷3"	5,0		63092

COD		 Kg.		
63177	2"÷4"	8,0	1	63186







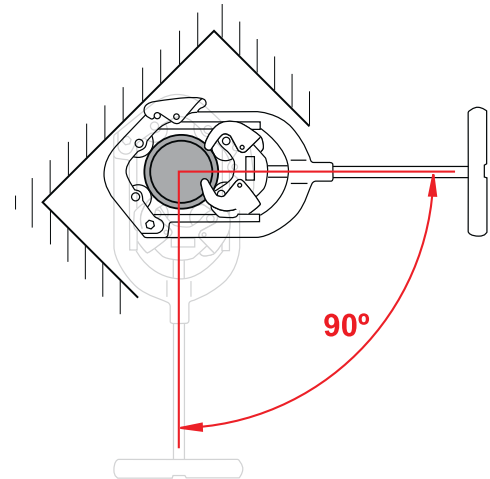

CORTATUBOS ARTICULADO / HINGED PIPE CUTTER / COUPE TUBES ARTICULÉ / UNIVERSAL ROHRABSCHNEIDER / TAGLIATUBI ARTICOLATO / CORTA TUBOS ARTICULADO / ТРУБОРЕЗ С ХОМУТНОЙ ЗАЩЕЛКОЙ















COD		 Kg.		
63359	2"÷4"	6,0	1	64196
63360	4"÷6"	9,0		64197
63361	6"÷8"	11		64198
63362	8"÷12"	16		64199













ESCARIADORES / REAMERS / ALESOIR / ENTGRATER / SBAVATORI / ESCARIADOR / ЗЕНКОВКА

COD						
63371	Cu / ACERO / PLÁSTICO / INOX Cu / STEEL / PLASTIC / INOX	90	20	1	64008	64447

COD						
63370	Cu / ACERO / PLÁSTICO / INOX Cu / STEEL / PLASTIC / INOX	50	20	1	64008	-

COD						
63369	Cu / ACERO / PLÁSTICO / INOX Cu / STEEL / PLASTIC / INOX	25	20	1	64008	-

COD						
63368	Cu / ACERO / PLÁSTICO / INOX Cu / STEEL / PLASTIC / INOX	10	20	1	64008	-

COD					
63958	Cu / ACERO / PLÁSTICO / INOX / LATÓN / ALUMINIO	8-35mm / 5/16"-1.3/8"	250	1	1
63959	Cu / STEEL / PLASTIC / INOX / BRASS / ALUMINIUM	10-54mm / 1/2"-2.1/8"	500		



**ESCARIADOR DE CHAFLANES / CHAMFERBIT / EBAVUREUR À CHANFREINS / ABSCHRÄGER / SBAVATORE PER  
 SMUSSI / ESCARIADOR DE CHANFROS / ЗЕНКОВКА С РУКОЯТКОЙ**

COD		MAX	Crestas Crests	gr.	Crestas Crests	gr.
63776	Cu / ACERO / PLÁSTICO / INOX Cu / STEEL / PLASTIC / INOX	12,4	3	100		6
63777		25		120		

Material: HSS (M2)

**FRESA CÓNICA / CONIC MILLING TOOL / FRAISE CONIQUE / SCHAFTFRÄSER KONISCH / FRESA CONICA /  
 FRESA CÓNICA / КОНИЧЕСКАЯ ЗЕНКОВКА С РУКОЯТКОЙ**

COD		MAX	Crestas Crests	gr.	Crestas Crests	gr.
63778	Cu / ACERO / PLÁSTICO / INOX Cu / STEEL / PLASTIC / INOX	10-34	6	150		6

Material: HSS

**ESCARIADOR CÓNICO / TAPER REAMER / EBAVUREUR CONIQUE / HANDREIBAHLEN / SBAVATORE CONICO /  
 ESCARIADOR CÓNICO / ЛЕНТОЧНАЯ ЗЕНКОВКА**

COD		MAX	Crestas Crests	gr.	Crestas Crests	gr.
63779	Cu / ACERO / PLÁSTICO / INOX Cu / STEEL / PLASTIC / INOX	3-12	6	100		6
63780		10-25	8	120		

Material: HSS

**RASQUETA / SCRAPER / RAGLOIR / ENTGRATER / SPATOLA / ESPÁTULA / ШАБЕР**

COD		gr.	Crestas Crests	gr.	Crestas Crests	gr.
63376	CU / ACERO / PLÁSTICO / INOX CU / STEEL / PLASTIC / INOX	60	20	1		64449

COD		L	Crestas Crests	gr.	Crestas Crests
64008	CU / STEEL / PLASTIC / INOX			47	6
64447	CU / STEEL / PLASTIC / INOX			26	20
64449	CU / STEEL / PLASTIC / INOX			120	20

**DEPILLOS PARA LIMPIEZA DE COBRE / COPPER CLEANING BRUSHES / BROSE DE NETTOYAGE POUR CUIVRE /  
 KUPFER - REINIGUNGSBÜRSTE / SPAZZOLE PER RAME / ESCOVAS PARA LIMPIEZA DE COBRE / ЩЕТКИ ДЛЯ  
 ЗАЧИСТКИ МЕДИ**

COD		gr.	Crestas Crests	gr.	Crestas Crests	gr.
63206	1/2"-3/4" INT. / EXT.	30	6	1		

COD		gr.	Crestas Crests	gr.	Crestas Crests	gr.
63207	1/2" INT. / EXT.	10	6	1		

COD		gr.	Crestas Crests	gr.	Crestas Crests	gr.
63208	1/2" INT.	5	6	1		



## HERRAMIENTA PARA INOX / STAINLESS STEEL TOOLS / OUTIL POUR INOX / EDELSTAHL-WERKZEUGE / UTENSILI PER ACCIAIO INOX / FERRAMENTA PARA INOX / ИНСТРУМЕНТЫ ИЗ НЕРЖАВЕЮЩЕЙ СТАЛИ

TENAZA CURVATUBOS / TUBE BENDER / PINCE À CINTRER / ZWEIHANDBIEGER / PINZA CURVATUBI / CURVADORA PARA TUBOS / ТРУБОГИБ

COD	O.D.		Kg.		
68010	6mm	<= 1mm	500	1	1
68011	8mm		600		
68012	10mm		900		
68013	12mm		950		
68014	14mm		1600		
68015	15mm		1700		
68016	16mm		2200		



AVOSINADOR CONO EXCÉNTRICO CON CARRACA / ECCENTRIC CONE FLARING TOOL WITH RATCHET / DUDGEONNIERE EXCENTRIQUE À CLIQUET / TAUMEL-BÖRDELGERÄT MIT RATSCHHE / FLANGIATUBI CON CRICCHETTO / AVOSCARDADOR CONO EXCÉNTRICO COM ROQUETE / РАЗВАЛЬЦОВКА С ЭКСЦЕНТРИЧЕСКИМ КОНУСОМ С ТРЕЩЕТКОЙ

COD	O.D.	90°	Kg.	
68096	1/4-5/16-3/8-1/2-5/8-3/4"	●	1,5	1
68095	6-8-10-12-14-15-16mm		1,5	
68098	1/4-5/16-3/8-1/2-5/8-3/4" 6-8-10-12-14-15-16mm		2,1	



CURVADORA ELECTROHIDRÁULICA / ELECTROHYDRAULIC PIPE BENDER / CINTREUSE ÉLECTROHYDRAULIQUE / ELEKTRO-HYDRAULISCHE ROHRBIEGEMASCHINE / CURVATUBI ELETTRICO-IDRAULICA / CURVADORA ELECTROHIDRÁULICA / ГИДРАВЛИЧЕСКИЙ ЗАГИБОЧНЫЙ СТАНОК

INOX / ACERO Hasta 4,5 mm  
STAINLESS STEEL / STEEL Up to 4,5 mm  
INOXIDABLE / ACIER jusqu'à 4,5 mm

COD		TONS.	V	Kg.	
60090	3/8"±1.1/2"	9	230V(50-60Hz)	150	1
60091			110V(50-60Hz)		



A	COD	B		Kg.	
64890	64897	3/8"	●	4	1
64891	64898	1/2"		4	
64892	64899	3/4"	4,5		
64893	64900	1"	4,7		
64894	64901	1.1/4"	8,5		
64895	64902	1.1/2"	14		



COD	W	V	Kg.	
60094	750	230V(50-60Hz)	30	1
60095		110V(50-60Hz)		





**INSPECCIÓN Y DESATASCADORES / DRAIN CLEANING AND INSPECTION /  
INSPECTION ET DEBOUCHEURS / ROHRINSPEKTION / STURATUBI E ISPEZIONE /  
INSPECÇÃO E DESENTUPIDORES / ПРОЧИСТНАЯ ТЕХНИКА И ВИДЕОДИАГНОСТИКА**

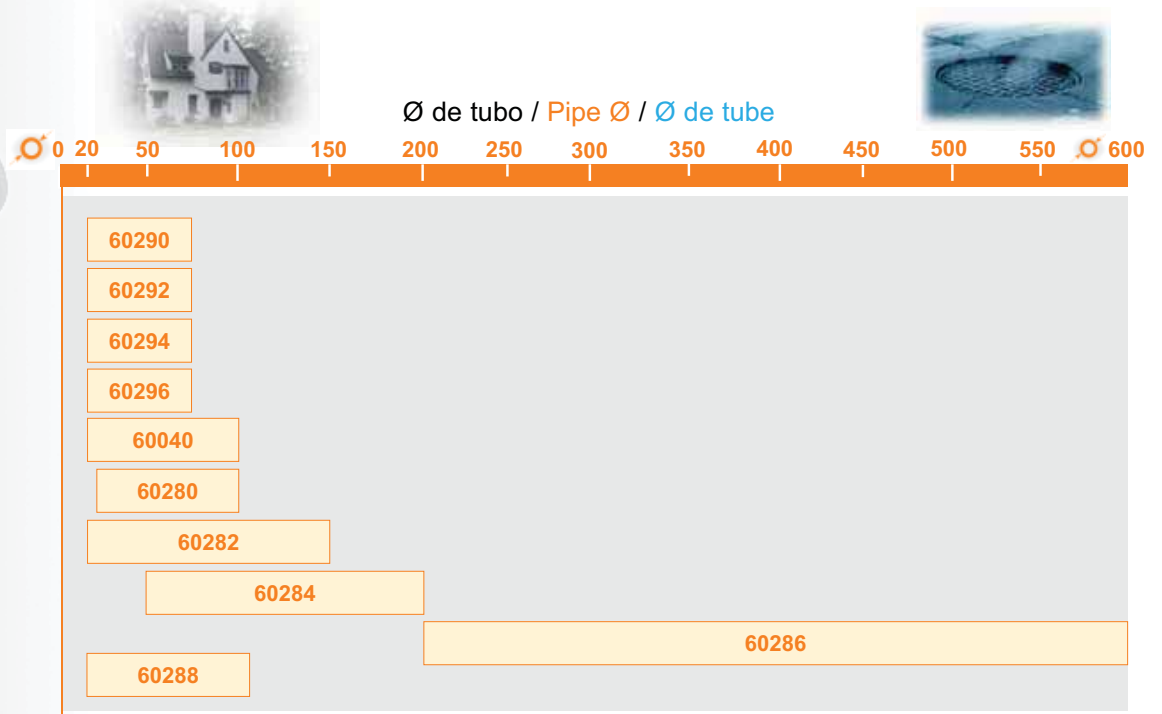

Ega Master es el fabricante mundial con mayor gama de desatascadores que permiten trabajar desde redes domésticas hasta grandes instalaciones.

Ega Master is the manufacturer in the world with the biggest range of pipe and drain cleaners which enables the user to work on small home pipes as well as on big facilities.

Ega Master est le fabricant avec le plus grande gamme au monde de déboucheurs, qui permettent le travail du réseau domestique aux grandes installations.

**4.** La amplia gama de desatascadores Ega Master comprende punteras desde 16mm hasta 30mm para cualquier trabajo.

The wide range of Ega Master pipe cleaners has different drill sizes from 16mm up to 30mm for any work.

La grande gamme de déboucheurs Ega Master comprend des embouts de 16mm à 30 mm pour tous les travaux.

**1.** Todos los desatascadores Ega Master tienen los elementos necesarios para un uso ergonómico y cómodo.

All the Ega Master pipe cleaners have the necessary elements to ensure an ergonomic and comfortable use.

Tous les déboucheurs Ega Master sont dotés d'éléments nécessaires à l'ergonomie et au confort d'utilisation.

**2.** El tubo protector permite un uso seguro sin ningún daño para el usuario profesional.

Protection tube enables professional users to have a safe use without any damage.

Le tube protecteur permet un usage sûr sans aucun risque de blessure pour l'utilisateur professionnel.

**3.** Se han diseñado pensando en todos los detalles, hasta los soportes plásticos para evitar dañar el suelo.

They have been designed taking into account all the details, even the plastic stands to avoid damaging the floor.

Ils ont été dessinés en pensant à tous les détails, jusqu'aux supports plats, pour éviter d'abîmer le sol.



Los distintos tipos de punteras se adaptan a cualquier tipo de trabajo de mantenimiento de redes.

The different type of drills are valid for any pipe or drain cleaning operation.

Les différents types d'embouts sont adaptés à tous types de travaux de maintenance de réseau.



Cada máquina incluye los equipos de seguridad necesarios.

Each machine includes all necessary safety equipment.

Chaque machine est vendue avec l'équipement de sécurité nécessaire.



Disponibles equipos a batería para trabajo cómodo e independiente del suministro eléctrico.

Models with battery are available for comfortable use.

Des équipements à batterie sont disponibles pour un travail aisé et non tributaire du réseau électrique.

DESATASCADORES / PIPE CLEANERS / DEBOUCHEURS / ROHRREINIGUNGSGERÄTE /  
 STURATUBI / DESENTUPIDORES / ПРОЧИСТНЫЕ МАШИНЫ

DESATASCADOR DE TAMBOR / PIPE CLEANER / DÉBOUCHEUR À TAMBOUR /  
 ELEKTROROHRREINIGUNGSGERÄT / STURATUBI A TAMBURO / DESENTUPIDOR DE TAMBOR / ПРОЧИСТНАЯ  
 МАШИНА

COD	L	gr.		Ø
69500	4,6 m	750	6	11 mm



DESATASCADOR DE MUELLE / SPRING PIPE CLEANER / RESSORT À DÉBOUCHER /  
 ROHRREINIGUNGSGERÄT / NETTATUBI / DESENTUPIDOR DE MOLA / СПИРАЛЬНАЯ ПРОЧИСТНАЯ МАШИНА

COD	L	gr.		Ø
69505	3 m	350	10	5 mm
69506	5 m	1400		24 mm
69507	10 m	2500	5	24 mm



	Ø	CAP
Drainmatic Handy 75	8mm (muelle / spring / ressort)	Ø20-Ø75mm
Drainmatic Handy 75 Auto		
Drainmatic Portable 75		
Drainmatic Portable 75 Auto		
Drainmatic 100	8mm - 16mm (muelle / spring / ressort)	Ø20-Ø100mm
Drainmatic MAX 100	16mm (muelle / spring / ressort)	Ø32-Ø100mm
Drainmatic MAX 110	12,5mm (muelle / spring / ressort)	Ø20-Ø110mm
Drainmatic MAX 150	8mm - 16mm - 22mm (muelle / spring / ressort)	Ø20-Ø150mm
Drainmatic MAX 200	30mm (muelle / spring / ressort)	Ø50-Ø200mm
Drainmatic MAX 600	8x22mm (varilla / rod / baguette)	Ø200-Ø600mm

EGA Master S.A.  
 ART IN INNOVATION

DESATASCADORES / PIPE CLEANERS / DEBOUCHEURS / ROHRREINIGUNGSGERÄTE /  
 STURATUBI / DESENTUPIDORES / ПРОЧИСТНЫЕ МАШИНЫ

DRAINMATIC HANDY 75



COD	V	W	rpm	CAP	Kg.
60290*	230V(50-60Hz)	600W	0-550rpm	Ø 20-75 mm	11
60291*	110V(50-60Hz)				

\* Incluye accesorios / Accessories included / Accessoires inclus

Especificaciones técnicas / Technical specification / Détails techniques	
Capacidad tubo / Pipe capacity / Capacité de tube	Ø 20-75 mm
Máxima longitud / Max. Length / Longueur max.	7,6m
Ø Cabeza muelle / Spring head Ø / Ø Tête ressort	Ø 15 mm
Ø Muelle / Ø Spring / Ø Diamètre de ressort	Ø 8mm
Velocidad de giro / Turning speed / Vitesse de rotation	0-550 rpm
Interruptor de cambio de sentido de giro / Turning way selector switch Bouton de changement de sens de rotation	●
Agarre ergonómico / Ergonomic grip / Prise ergonomique	●
Tambor de cable en 2 piezas metálicas resistentes al impacto y corrosión / 2 piece spring canister resistant to impact and corrosion / Tambour de câble en 2 pièces métalliques résis- tant au choc et à la corrosion	●
Ligero y fácil de usar / Lightweight and easy-to-use / Léger et facile à utiliser	●
Peso en uso / Working weight / Poids en travail	6,0 Kg
Potencia / Power / Puissance	600 W

ACCESORIOS INCLUIDOS / INCLUDED SPARE PARTS / ACCESSOIRES INCLUS / ERSATZTEILE INBEGRIFFEN /  
 ACCESSORI INCLUSI / ACESSÓRIOS INCLUÍDOS / С ЗАПАСНЫМИ ЧАСТЯМИ

COD	LxWxH	Kg.
64648	550x245x250 mm	4,0



COD	Ø x L	Kg.
85114	Ø 8mm x 7,6m	1,8





## DRAINMATIC HANDY 75 AUTO



COD	V	W	rpm	CAP	Kg.
60292*	230V(50-60Hz)	600W	0-550rpm	Ø 20-75 mm	11
60293*	110V(50-60Hz)				

\* Incluye accesorios / Accessories included / Accessoires inclus

Especificaciones técnicas / Technical specification / Détails techniques	
Avance de muelle automático / Automatic spring advance / Avance du ressort automatique	●
Velocidad de avance de muelle / Spring advance speed / Vitesse d'avance du ressort	5m/min
Capacidad tubo / Pipe capacity / Capacité de tube	Ø 20-75 mm
Máxima longitud / Max. Length / Longueur max.	7,6m
Ø Cabeza muelle / Spring head Ø / Ø Tête ressort	Ø 15 mm
Ø Muelle / Ø Spring / Ø Diamètre de ressort	Ø 8mm
Velocidad de giro / Turning speed / Vitesse de rotation	0-550 rpm
Interruptor de cambio de sentido de giro / Turning way selector switch / Bouton de changement de sens de rotation	●
Agarre ergonómico / Ergonomic grip / Prise ergonomique	●
Tambor de cable en 2 piezas metálicas resistentes al impacto y corrosión / 2 piece spring canister resistant to impact and corrosion / Tambour de câble en 2 pièces métalliques résistant au choc et à la corrosion	●
Ligero y fácil de usar / Lightweight and easy-to-use / Léger et facile à utiliser	●
Peso en uso / Working weight / Poids en travail	6,0 Kg
Potencia / Power / Puissance	600 W

ACCESORIOS INCLUIDOS / INCLUDED SPARE PARTS / ACCESSOIRES INCLUS / ERSATZTEILE INBEGRIFFEN /  
 ACCESSORI INCLUSI / ACESSÓRIOS INCLUÍDOS / С ЗАПАСНЫМИ ЧАСТЯМИ

COD	LxWxH	Kg.
64648	550x245x250 mm	4,0



COD	Ø x L	Kg.
85114	Ø 8mm x 7,6m	1,8



COD	Velocidad / Speed	Kg.
83694	5m/min	0,5



## DRAINMATIC PORTABLE 75



CE\*G12

COD	V	W	rpm	CAP	Kg.
60294*	230V(50-60Hz)	600W	0-450rpm	Ø 20-75 mm	11
60295*	110V(50-60Hz)				

\* Incluye accesorios / Accessories included / Accessoires inclus

## Especificaciones técnicas / Technical specification / Détails techniques

Capacidad tubo / Pipe capacity / Capacité de tube	Ø 20-75 mm
Máxima longitud / Max. Length / Longueur max.	6m
Ø Cabeza muelle / Spring head Ø / Ø Tête ressort	Ø 15 mm
Ø Muelle / Ø Spring / Ø Diamètre de ressort	Ø 8mm
Velocidad de giro / Turning speed / Vitesse de rotation	0-450 rpm
Interruptor de cambio de sentido de giro / Turning way selector switch Bouton de changement de sens de rotation	●
Agarre ergonómico / Ergonomic grip / Prise ergonomique	●
Tambor de cable en 2 piezas metálicas resistentes al impacto y corrosión / 2 piece spring canister resistant to impact and corrosion / Tambour de câble en 2 pièces métalliques résis- tant au choc et à la corrosion	●
Ligero y fácil de usar / Lightweight and easy-to-use / Léger et facile à utiliser	●
Peso en uso / Working weight / Poids en travail	5,5 Kg
Batería Ni-mh / Battery Ni-mh / Batterie Ni-mh	14,4V - 2400mAh
Potencia / Power / Puissance	600 W

ACCESORIOS INCLUIDOS / INCLUDED SPARE PARTS / ACCESSOIRES INCLUS / ERSATZTEILE INBEGRIFFEN /  
 ACCESSORI INCLUSI / ACESSÓRIOS INCLUIDOS / С ЗАПАСНЫМИ ЧАСТЯМИ

COD	LxWxH	Kg.
64648	550x245x250 mm	4,0



COD	Ø x L	Kg.
85115	Ø 8mm x 6m	1,4



COD	V	Kg.
83696	14,4V	0,8



COD	V	Kg.
64649	230V(50-60Hz)	1,2
64650	110V(50-60Hz)	



\*G12: GARANTIA 12 MESES / 12 MONTHS OF WARRANTY / 12 MOIS DE GARANTIE / 12 MONATEN GARANTIE / 12 MAANDEN GARANTIE / 12 MESI DI GARANZIA / 12 МЕСЯЦЕВ ГАРАНТИЯ

## DRAINMATIC PORTABLE 75 AUTO



CE\*G12

COD	V	W	rpm	CAP	Kg.
60296*	230V(50-60Hz)	600W	0-450rpm	Ø 20-75 mm	11
60297*	110V(50-60Hz)				

\* Incluye accesorios / Accessories included / Accessoires inclus

Especificaciones técnicas / Technical specification / Détails techniques	
Avance de muelle automático / Automatic spring advance / Avance du ressort automatique	●
Velocidad de avance de muelle / Spring advance speed / Vitesse d'avance du ressort	5m/min
Capacidad tubo / Pipe capacity / Capacité de tube	Ø 20-75 mm
Máxima longitud / Max. Length / Longueur max.	6m
Ø Cabeza muelle / Spring head Ø / Ø Tête ressort	Ø 15 mm
Ø Muelle / Ø Spring / Ø Diamètre de ressort	Ø 8mm
Velocidad de giro / Turning speed / Vitesse de rotation	0-450 rpm
Interruptor de cambio de sentido de giro / Turning way selector switch / Bouton de changement de sens de rotation	●
Agarre ergonómico / Ergonomic grip / Prise ergonomique	●
Tambor de cable en 2 piezas metálicas resistentes al impacto y corrosión / 2 piece spring canister resistant to impact and corrosion / Tambour de câble en 2 pièces métalliques résistant au choc et à la corrosion	●
Ligero y fácil de usar / Lightweight and easy-to-use / Léger et facile à utiliser	●
Peso en uso / Working weight / Poids en travail	6,0 Kg
Batería Ni-mh / Battery Ni-mh / Batterie Ni-mh	14,4V - 2400mAh
Potencia / Power / Puissance	600 W

ACCESORIOS INCLUIDOS / INCLUDED SPARE PARTS / ACCESSOIRES INCLUS / ERSATZTEILE INBEGRIFFEN /  
 ACCESSORI INCLUSI / ACESSÓRIOS INCLuíDOS / СПАСИМЫЕ ЧАСТЯМИ

COD	LxWxH	Kg.
64648	550x245x250 mm	3,5
COD	Ø x L	Kg.
85115	Ø 8mm x 6m	1,4
COD	Velocidad / Speed	Kg.
83694	5m/min	0,5
COD	V	Kg.
83696	14,4V	0,8
COD	V	Kg.
64649	230V(50-60Hz)	1,2
64650	110V(50-60Hz)	



**DRAINMATIC 100**

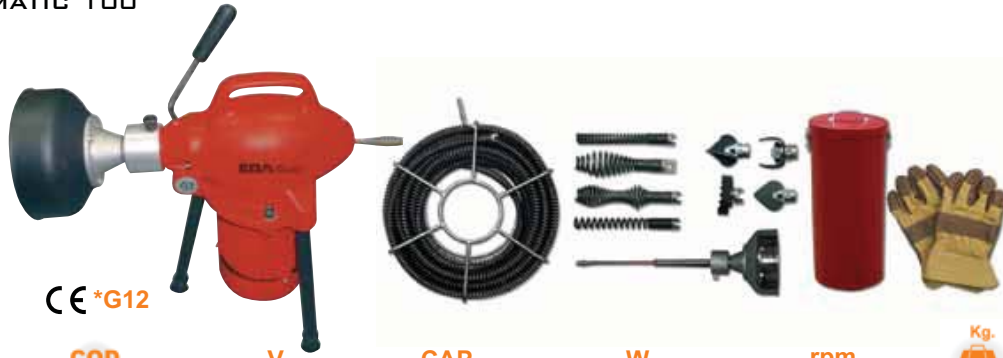

CE\*G12

COD	V	CAP	W	rpm	Kg.
60040*	230V(50-60Hz)	Ø 20-100 mm	390 W	400 rpm	32
60041*	110V(50-60Hz)				

\* Incluye accesorios / Accessories included / Accessoires inclus

**Especificaciones técnicas / Technical specification / Détails techniques**

Capacidad tubo / Pipe capacity / Capacité de tube	Ø 20-100 mm
Máxima longitud / Max. Length / Longueur max.	30 m
Ø Muelle / Ø Spring / Ø Diamètre de ressort	Ø 8 - 16 mm
Velocidad de giro / Turning speed / Vitesse de rotation	400 rpm
Interruptor de cambio de sentido de giro / Turning way selector switch Bouton de changement de sens de rotation	●
Agarre ergonómico / Ergonomic grip / Prise ergonomique	●
Guantes incluidos / Gloves included / Gants inclus	●
Máxima estabilidad / Maximum stability / Stabilité maximale	●
Ligero y fácil de usar / Lightweight and easy-to-use / Léger et facile à utiliser	●
Peso en uso / Working weight / Poids en travail	12 Kg
Potencia / Power / Puissance	390 W

**ACCESORIOS INCLUIDOS / INCLUDED SPARE PARTS / ACCESSOIRES INCLUS / ERSATZTEILE INBEGRIFFEN /  
ACCESSORI INCLUSI / ACESSÓRIOS INCLUIDOS / С ЗАПАСНЫМИ ЧАСТЯМИ**

COD	Ø	L	gr.		
85104	8 mm	4,5m	2350		
64240	16 mm	135 mm	70		
64241			50		
64242		100 mm	70		
64249		130 mm	85		
64243		35 mm	32		
64244		28 mm	35		
64245		37 mm	25		
64246		40 mm			
64248		8x2,5m		9750	
85103			2,5m	1200	
64624	-	-	100		

## DRAINMATIC MAX 100



COD	V	CAP	W	rpm	Kg.
60280*	230V(50-60Hz)	Ø 32-100 mm	390 W	400 rpm	22
60281*	110V(50-60Hz)				

\* Incluye accesorios / Accessories included / Accessoires inclus

**Especificaciones técnicas / Technical specification / Détails techniques**

Capacidad tubo / Pipe capacity / Capacité de tube	Ø 32-100 mm
Máxima longitud / Max. Length / Longueur max.	30 m
Ø Muelle / Ø Spring / Ø Diamètre de ressort	Ø 16 mm
Velocidad de giro / Turning speed / Vitesse de rotation	400 rpm
Interruptor de cambio de sentido de giro / Turning way selector switch / Bouton de changement de sens de rotation	●
Agarre ergonómico / Ergonomic grip / Prise ergonomique	●
Guantes incluidos / Gloves included / Gants inclus	●
Tubo de seguridad incluido / Safe tube included / Tube de sécurité inclus	●
Máxima estabilidad / Maximum stability / Stabilité maximale	●
Ligero y fácil de usar / Lightweight and easy-to-use / Léger et facile à utiliser	●
Peso en uso / Working weight / Poids en travail	12 Kg
Potencia / Power / Puissance	390 W

**ACCESORIOS INCLUIDOS / INCLUDED SPARE PARTS / ACCESSOIRES INCLUS / ERSATZTEILE INBEGRIFFEN /  
 ACCESSORI INCLUSI / ACESSÓRIOS INCLUÍDOS / С ЗАПАСНЫМИ ЧАСТЯМИ**

COD			gr.	
64240	16 mm	135 mm	70	
64241			50	
64243	16 mm	35 mm	32	
64245			25	
64611	40 mm	4m	7700	
85103			1200	
64623	40 mm	4m	2300	
64624	-	-	100	

**DRAINMATIC MAX 150**

COD	V	CAP	W	rpm	Kg.
60282*	230V(50-60Hz)	Ø 20-150 mm	390 W	400 rpm	42
60283*	110V(50-60Hz)				

\* Incluye accesorios / Accessories included / Accessoires inclus

Especificaciones técnicas / Technical specification / Détails techniques	
Capacidad tubo / Pipe capacity / Capacité de tube	Ø 20-150 mm
Máxima longitud / Max. Length / Longueur max.	30 m
Ø Muelle / Ø Spring / Ø Diamètre de ressort	Ø 8-16-22 mm
Velocidad de giro / Turning speed / Vitesse de rotation	400 rpm
Interruptor de cambio de sentido de giro / Turning way selector switch / Bouton de changement de sens de rotation	●
Agarre ergonómico / Ergonomic grip / Prise ergonomique	●
Guantes incluidos / Gloves included / Gants inclus	●
Tubo de seguridad incluido / Safe tube included / Tube de sécurité inclus	●
Maxima estabilidad / Maximum stability / Stabilité maximale	●
Ligero y fácil de usar / Lightweight and easy-to-use / Léger et facile à utiliser	●
Peso en uso / Working weight / Poids en travail	16 Kg
Potencia / Power / Puissance	390 W

ACCESORIOS INCLUIDOS / INCLUDED SPARE PARTS / ACCESSOIRES INCLUS / ERSATZTEILE INBEGRIFFEN /  
 ACCESSORI INCLUSI / ACESSÓRIOS INCLUÍDOS / С ЗАПАСНЫМИ ЧАСТЯМИ

COD	Ø	L	gr.	
85100	8 mm	4,5	2350	
64240	16 mm	135 mm	70	
64241			50	
64249		130 mm	85	
64243		35 mm	32	
64628	22 mm	190 mm	165	
64629		140 mm	175	
64626		57 mm	60	
64625		65 mm	80	
64630	16 mm	6,0x2,5 m	7700	
85103				2,5m
64631	22 mm	3x5 m	10000	
85101		5,0 m	2000	
64623	40 mm	4,0 m	2300	
64624	-	-	100	

## DRAINMATIC MAX 200



CE\*G12

COD	V	CAP	W	rpm	Kg.
60284*	230V(50-60Hz)	Ø 50-200 mm	1100W	700 rpm	80
60285*	110V(50-60Hz)				

\* Incluye accesorios / Accessories included / Accessoires inclus

## Especificaciones técnicas / Technical specification / Détails techniques

Capacidad tubo / Pipe capacity / Capacité de tube	Ø 50-200 mm
Máxima longitud / Max. Length / Longueur max.	50 m
Ø Muelle / Ø Spring / Ø Diamètre de ressort	Ø 30 mm
Velocidad de giro / Turning speed / Vitesse de rotation	700 rpm
Interruptor de cambio de sentido de giro / Turning way selector switch / Bouton de changement de sens de rotation	●
Guantes incluidos / Gloves included / Gants inclus	●
Tubo de seguridad incluido / Safe tube included / Tube de sécurité inclus	●
Máxima estabilidad / Maximum stability / Stabilité maximale	●
Ligero y fácil de usar / Lightweight and easy-to-use / Léger et facile à utiliser	●
Peso en uso / Working weight / Poids en travail	45 Kg
Potencia / Power / Puissance	1100 W

ACCESORIOS INCLUIDOS / INCLUDED SPARE PARTS / ACCESSOIRES INCLUS / ERSATZTEILE INBEGRIFFEN /  
 ACCESSORI INCLUSI / ACESSÓRIOS INCLUIDOS / С ЗАПАСНЫМИ ЧАСТЯМИ

COD	Ø	L	gr.	
64632	30 mm	80 mm	150	
64634		195 mm	600	
64635		75 mm	280	
64636		265 mm	360	
64637		205 mm	380	
64638		120 mm	235	
64623		40 mm	4m	2300
64633	30 mm	4x5 m	28000	
85102		5 m	7000	
64624	-	-	100	

### DRAINMATIC MAX 600



CE\*G12

COD	V	CAP	W	rpm	Kg.
60286*	230V(50-60Hz)	Ø 200-600 mm	1600W	100-600 rpm	140
60287*	110V(50-60Hz)				

\* Incluye accesorios / Accessories included / Accessoires inclus

#### Especificaciones técnicas / Technical specification / Détails techniques

Capacidad tubo / Pipe capacity / Capacité de tube	Ø 200-600 mm
Máxima longitud / Max. Length / Longueur max.	50 m
Velocidad de giro / Turning speed / Vitesse de rotation	100-600 rpm
Interruptor de cambio de sentido de giro / Turning way selector switch / Bouton de changement de sens de rotation	●
Guantes incluidos / Gloves included / Gants inclus	●
Sistema de varillas / Rod system / Système de baguette	●
Máxima estabilidad / Maximum stability / Stabilité maximale	●
Fácil de transportar / Easy to transport / Facile à transporter	●
Peso en uso / Working weight / Poids en travail	120 Kg
Potencia / Power / Puissance	1600 W

ACCESORIOS INCLUIDOS / INCLUDED SPARE PARTS / ACCESSOIRES INCLUS / ERSATZTEILE INBEGRIFFEN /  
ACCESSORI INCLUSI / ACESSÓRIOS INCLUIDOS / С ЗАПАСНЫМИ ЧАСТЯМИ

COD	Ø	L	gr.	Image
64639	22 mm	250 mm	410	
64640		250 mm	330	
64641	8,0mm x 22mm	240 mm	320	
64642		250 mm	340	
64643	-	300 mm	2150	
64669		30x1,5 m	16500	
64653	-	1,5 m	2200	
64624	-	-	100	

\*G12: GARANTIA 12 MESES / 12 MONTHS OF WARRANTY / 12 MOIS DE GARANTIE / 12 MONATEN GARANTIE / 12 MAANDEN GARANTIE / 12 MESI DI GARANZIA / 12 МЕСЯЦЕВ ГАРАНТИЯ



## DRAINMATIC MAX 110



CE\*G12

COD	V	CAP	W	rpm	Kg.
60288*	230V(50-60Hz)	Ø 20-110 mm	370W	260rpm	31
60289*	110V(50-60Hz)				

\* Incluye accesorios / Accessories included / Accessoires inclus

Especificaciones técnicas / Technical specification / Détails techniques	
Avance de muelle automático / Automatic spring advance / Avance du ressort automatique	●
Velocidad de avance de muelle / Spring advance speed / Vitesse d'avance du ressort	6m/min
Capacidad tubo / Pipe capacity / Capacité de tube	Ø 20-110 mm
Máxima longitud / Max. Length / Longueur max.	22,5 m
Ø Muelle / Ø Spring / Ø Diamètre de ressort	Ø 12,5 mm
Velocidad de giro ajustable / Adjustable turning speed / Vitesse de rotation réglable	260 rpm
Interruptor de cambio de sentido de giro / Turning way selector switch / Bouton de changement de sens de rotation	●
Guantes incluidos / Gloves included / Gants inclus	●
Tubo de seguridad incluido / Safe tube included / Tube de sécurité inclus	●
Máxima estabilidad / Maximum stability / Stabilité maximale	●
Fácil de transportar / Easy to transport / Facile à transporter	●
Peso en uso / Working weight / Poids en travail	28 Kg
Potencia / Power / Puissance	370 W

ACCESORIOS INCLUIDOS / INCLUDED SPARE PARTS / ACCESSOIRES INCLUS / ERSATZTEILE INBEGRIFFEN /  
 ACCESSORI INCLUSI / ACESSÓRIOS INCLUIDOS / С ЗАПАСНЫМИ ЧАСТЯМИ

COD	Ø	L	gr.	
64644	12 mm	135 mm	50	
64645		100 mm	70	
64646		28 mm	35	
64647		37 mm	25	
64683	40 mm	-	2200	
64624	-	-	100	

\*G12: GARANTIA 12 MESES / 12 MONTHS OF WARRANTY / 12 MOIS DE GARANTIE / 12 MONATEN GARANTIE / 12 MAANDEN GARANTIE / 12 MESI DI GARANZIA / 12 МЕСЯЦЕВ ГАРАНТИЯ  
 NATO Commercial and Government Entity (NCAGE) Code / Código (NCAGE) OTAN: 8552B



**ACCESORIOS DISPONIBLES / AVAILABLE ACCESSORIES / ACCESSOIRES DISPONIBLES / VORHANDENE ERSATZTEILE / ACCESSORI DISPONIBILI / ACESSÓRIOS DISPONÍVEIS / ИМЕЮЩЕЕСЯ ВСПОМОГАТЕЛЬНОЕ ОБОРУДОВАНИЕ**

<b>COD</b>	<b>Descripción / Description</b>				<b>Para máquinas / For machines</b>		
64644	Taladro en forma de hélice colecta Collection helical drills Hélicoïdal long embout	12,5 mm	135 mm	50	60288, 60289		
64645	Taladro en forma de hélice abombada Olive-shaped helical drills Embout hélicoïdal bombé		100 mm	70	60288, 60289		
64646	Cortador de sierra helicoidal Helical saw cutters Embout á lame circulaire		28 mm	35	60288, 60289		
64647	Cortador en forma de pala Spade-shaped cutters Embout á lame plate		37 mm	25	60288, 60289		
64240	Taladro en forma de hélice recta Straight helical drills Embout hélicoïdal droit	16 mm	135 mm	70	60040, 60041, 60280, 60281, 60282, 60283		
64241	Taladro en forma de hélice colecta Collection helical drills Hélicoïdal long embout			50	60040, 60041, 60280, 60281, 60282, 60283		
64242	Taladro en forma de hélice abombada Olive-shaped helical drills Embout hélicoïdal bombé		100 mm	70	60040, 60041		
64243	Cortador de sierra de 4 filos 4-edged saw cutters Embout á 4 taillants		35 mm	32	60040, 60041, 60280, 60281, 60282, 60283		
64244	Cortador de sierra helicoidal Helical saw cutters Embout á lame circulaire		28 mm	35	60040, 60041		
64245	Cortador en forma de pala Spade-shaped cutters Embout á lame plate		37 mm	25	60040, 60041, 60280, 60281		
64246	Cortador en forma de C C shaped cutters Embout á lame en C		40 mm		60040, 60041		
64249	Extensión de tubo Flexible olive-shaped helical drills Rallonge de tube		130 mm	85	60040, 60041, 60280, 60281		
64628	Taladro en forma de hélice recta Straight helical drills Embout hélicoïdal droit		22 mm	190 mm	165	60282, 60283	
64629	Taladro en forma de embudo helicoidal Funnel shaped helical drills Embout conique	140 mm		175	60282, 60283		
64639	Cortador de sierra helicoidal Helical saw cutters Embout á lame circulaire	250 mm			410	60286, 60287	
64640	Taladro en forma de hélice colecta Collection helical drills Hélicoïdal long embout				330	60286, 60287	
64641	Cortador en forma de pala Spade-shaped cutters Embout á lame plate	240 mm		320	60286, 60287		
64642	Taladro en forma de hélice colecta Collection helical drills Hélicoïdal long embout	250 mm		340	60286, 60287		
64643	Adaptador Bumper Adaptateur	300 mm		2150	60286, 60287		
64625	Cortador de sierra de 4 filos 4-edged saw cutters Embout á 4 taillants	65 mm		80	60282, 60283		
64626	Cortador en forma de pala Spade-shaped cutters Embout á lame plate	57 mm		60	60282, 60283		

COD	Descripción / Description				Para máquinas / For machines		
64636	Taladro en forma de hélice recta Straight helical drills Embout hélicoïdal droit	30 mm	265 mm	360	60284, 60285		
64634	Taladro en forma de embudo helicoidal Funnel shaped helical drills Embout conique		195 mm	600	60284, 60285		
64637	Taladro en forma de hélice colecta Collection helical drills Hélicoïdal long embout		205 mm	380	60284, 60285		
64638	Cortador en forma de C C shaped cutters Embout à lame en C		120 mm	230	60284, 60285		
64632	Cortador en forma de pala Spade-shaped cutters Embout à lame plate		80 mm	150	60284, 60285		
64635	Cortador de sierra helicoidal Helical saw cutters Embout à lame circulaire		75 mm	280	60284, 60285		
85104	Alargadera Spring holder Rallonge	8 mm	4,5 m	2350	60040, 60041		
85100					60282, 60283		
64248	Alargadera Spring holder Rallonge	16 mm	20 m	9750	60040, 60041		
64611	Alargadera Spring holder Rallonge		15 m	7700	60280, 60281		
64630	Alargadera Spring holder Rallonge		15 m	7600	60282, 60283		
85103	Alargadera Spring holder Rallonge		2,5 m	1200	60040, 60041, 60280, 60281, 60282, 60283		
64631	Alargadera Spring holder Rallonge		22 mm	15 m	11500	60282, 60283	
85101	Alargadera Spring holder Rallonge			5 m	2000	60282, 60283	
85102	Alargadera Spring holder Rallonge	30 mm	20 m	7000	60284, 60285		
64633	Alargadera Spring holder Rallonge			28000	60284, 60285		
64669	Varilla Rod Baguette	8 x 22mm	30 x 1,5m	16500	60286, 60287		
64653	Varilla Rod Baguette		1,5m	2200	60286, 60287		
64623	Extensión de tubo Vent-pipe extension Rallonge de tube	40 mm	4m	2300	60280, 60281, 60288, 60289, 60282, 60283, 60284, 60285		
64683	Tubo protector Pipe protector Tube protecteur	40mm	-	2200	60288,		
64624	Guantes protectores Protection gloves Gants protecteurs	-	-	100	60280, 60281, 60284, 60285, 60286, 60287, 60288, 60289		

## MASTERVISION REC



COD	V	CAP			
60060	110V- 230V	Ø40-Ø200mm	20m	1	12
60061	(50-60Hz)		30m		



## Especificaciones técnicas / Technical specification / Détails techniques

Cámara INOX / INOX camera / Boitier INOX	Ø26mm (1")
Longitud total cable / Cable total length / Longueur totale de câble	60060 - 20m (66') 60061 - 30m (100')
Barra empuje flexible / Flexible push rod / Barre de pulsion flexible	60060 - 20m (66') 60061 - 30m (100')
Inspección de tubos / Pipe inspection / Inspection de tubes	Ø40-Ø200mm
Monitor / Monitor / Moniteur	320x960 Pixel 7" TFT color
Baterías / Batteries / batterie	12V DC 1800mA
Cámara estanca / Waterproof camera / Boitier étanche	IP X8
Salida de video / Video output / Sortie de video	●
Grabación de video por medio de USB / USB recording system / Enregistrement video par USB	●
Lector de tarjetas / Card reader / Lecteur de cartes	USB
Tensión entrada / Input voltage / Voltage d'alimentation	100-240V
Maleta / Case / Malette	53,5x22x47,5cm
Sensor luminosidad / Illumination sensor / Senseur de luminosité	COLOR CCD
Profundidad visual / Depth of view / Profondeur visuelle	400mm
Campo visual / Field of view / Champ visuel	60°
Fuente de luz blanca / White light source / Source de lumière blanche	8 LED
Temperatura trabajo / Working temperature / Température de travail	-28°C - 50°C / -18° F -122° F
Carrete de cable 20m / Ø 20m cable reel / Ø 20m enrouleur de câbles	60056
Carrete de cable 30m / Ø 30m cable reel / Ø 30m enrouleur de câbles	60057
Bolígrafo USB 1 Gb con puntero láser / 1 Gb pendrive with laser pointer / Stylo USB 1 Gb avec pointe laser	●

## MASTERVISION ECO



CE \*G12

COD	V	CAP			
60062	110V- 230V (50-60Hz)	Ø40-Ø200mm	20m	1	12
60063			30m		

## Especificaciones técnicas / Technical specification / Détails techniques

Cámara INOX / INOX camera / Boitier INOX	Ø26mm (1")
Longitud total cable / Cable total length / Longueur totale de câble	60062 - 20m (66') 60063 - 30m (100')
Barra empuje flexible / Flexible push rod / Barre de pulsion flexible	60062 - 20m (66') 60063 - 30m (100')
Inspección de tubos / Pipe inspection / Inspection de tubes	Ø40-Ø200mm
Monitor / Monitor / Moniteur	320x960 Pixel 7" TFT color
Baterías / Batteries / batterie	12V DC 1800mA
Cámara estanca / Waterproof camera / Boitier étanche	IP X8
Salida de video / Video output / Sortie de video	●
Tensión entrada / Input voltage / Voltage d'alimentation	100-240V
Maleta / Case / Malette	53,5x22x47,5cm
Sensor luminosidad / Illumination sensor / Senseur de luminosité	COLOR CCD
Profundidad visual / Depth of view / Profondeur visuelle	400mm
Campo visual / Field of view / Champ visuel	60°
Fuente de luz blanca / White light source / Source de lumière blanche	8 LED
Temperatura trabajo / Working temperature / Température de travail	-28°C - 50°C / -18° F -122° F
Carrete de cable 20m / Ø 20m cable reel / Ø 20m enrouleur de câbles	60056
Carrete de cable 30m / Ø 30m cable reel / Ø 30m enrouleur de câbles	60057



**MASTERVISION MINI REC ZOOM**



**RECORDING**



<b>COD</b>	<b>L</b>	<b>Ø (mm)</b>	<b>Kg.</b>
60119	1m(3')	4,5	2
60125	2m(6')	5,5	
60134	1m(3')	9	3
60139	5m(15')	11	
60144	1m(3')	16	2

**MASTERVISION MINI REC ● ZOOM**

Especificaciones técnicas / Technical specification / Détails techniques	
Longitud de inspección / <i>Inspection length</i> / <i>Longueur d'inspection</i>	1m (3') hasta 9m / 1m (3') up to 9m / 1m (3') jusqu'à 9m
Iluminación / <i>Lighting</i> / <i>Illumination</i>	4,5mm: 4led / 5,5mm: 4led / 9mm: 4led / 11mm: 4led / 16mm: 2led
Cámara estanca / <i>Waterproof camera</i> / <i>Boîtier étanche</i>	IP67
Salida de video PAL/NTSC / <i>PAL/NTSC Video output</i> / <i>Sortie vidéo PAL/NTSC</i>	●
Sistema de visión directa / <i>Direct vision system</i> / <i>Système de vision directe</i>	PAL
Conexión / <i>Connection</i> / <i>Connection</i>	mini-USB
Grabación de video y captación de foto / <i>Video recording and photographing</i> / <i>Enregistrement vidéo et capture de photo</i>	Micro SD 4Gb incluida (hasta 16 Gb) Micro SD 4Gb included (up to 16 Gb) Micro SD 4Gb incluse (jusqu'à 16GB)
<b>ZOOM</b>	⊙x3
Formato de compresión / <i>Compression format</i> / <i>Format de compression</i>	Foto-Photo JPG / AVI Video
Monitor / <i>Monitor</i> / <i>Moniteur</i>	320(RGB)x240Pixel 3,5" TFT-LCD
Dimensiones del monitor / <i>Monitor dimensions</i> / <i>Dimensions du moniteur</i>	105x92x42mm
Idiomas del menú / <i>Menu languages</i> / <i>Langues du menu</i>	10
Batería para el monitor / <i>Battery for the monitor</i> / <i>Batterie du moniteur</i>	3,7V , 1,2 Ah - Batería de litio-ión / <i>Ion-Lithium battery</i> / <i>Batterie en lithium-ion</i>
Tiempo de carga / <i>Charge time</i> / <i>Temps de recharge</i>	4h
Duración de la batería / <i>Battery operation time</i> / <i>Durée de la batterie</i>	2h
Sensor de imagen / <i>Imaging sensor</i> / <i>Senseur d'image</i>	CMOS
Pixels en imagen / <i>Image pixels</i> / <i>Pixels en image</i>	704x575
Campo de visión / <i>Field of view</i> / <i>Champ de vision</i>	50°
Dimensiones de la cámara / <i>Camera dimensions</i> / <i>Dimensions de la caméra</i>	195x165x55mm
Pilas / <i>Batteries</i> / <i>Piles</i>	4x1,5V AA
Temperatura de trabajo / <i>Working temperature</i> / <i>Température de travail</i>	-10°C - 50°C / 14°F - 122°F
Regulación de la intensidad luminosa / <i>Light intensity regulation</i> / <i>Régulateur de l'intensité de l'image</i>	●
Pantalla extraíble WIFI / <i>WIFI Removable screen</i> / <i>WIFI Écran extractible</i>	●
Sistema inalámbrico / <i>Wireless system</i> / <i>Système sans fil</i>	●
Grabación de voz / <i>Voice recording</i> / <i>Enregistrement vocal</i>	●
Maleta / <i>Case</i> / <i>Malette</i>	●
Inspección de tuberías / <i>Pipe inspection</i> / <i>Inspection de tuyauterie</i>	●
Inspección de tejados con goteras / <i>Leaking water ceiling inspection</i> / <i>Inspection de toits avec gouttières</i>	●
Inspección de muros en construcción / <i>Wall inspection while bilding</i> / <i>Inspection de murs en phase de construction</i>	●
Inspección de motores / <i>Engine inspection</i> / <i>Inspection de moteurs</i>	●
∅ fibra óptica / <i>spare camera head ∅</i> / <i>∅ fibre optique</i>	cod: 60097 - 4,5mm / L: 1m cod: 60098 - 4,5mm / L: 2m **cod: 60071 - 9mm / L: 1m **cod: 60088 - 9mm / L: 5m cod: 60096 - 11mm / L: 1m **cod: 60070 - 16mm / L: 1m
Extensión 1m / <i>1m extension</i> / <i>Extension 1m</i>	*cod: 60069
Accesorios incluidos para la cabeza de cámara de 9mm / <i>Included spare parts for 9mm camera head</i> / <i>Accessoires inclus pour la tête de caméra de 9mm</i>	cod.60075: 45° espejo / <i>mirror</i> / <i>miroir</i> à 45° cod. 60076: gancho / <i>hook</i> / <i>crochet</i> cod. 60077: imán / <i>magnet</i> / <i>aimant</i> cod. 60078: protector / <i>protector</i> / <i>protecteur</i>
Accesorios incluidos para la cabeza de cámara de 16mm / <i>Included spare parts for 16mm camera head</i> / <i>Accessoires inclus pour la tête de caméra de 16mm</i>	cod. 60072: 45° espejo / <i>mirror</i> / <i>miroir</i> à 45° cod. 60073: gancho / <i>hook</i> / <i>crochet</i> cod. 60074: imán / <i>magnet</i> / <i>aimant</i>

 \*Sólo para 60159 / *Only for 60159* / *Uniquement pour 60159*

 \*\* Incluye accesorios / *Accessories included* / *Accessoires inclus*

MASTERVISION MINI REC



**RECORDING** ●



<b>COD</b>	<b>L</b>	<b>Ø (mm)</b>	<b>Kg.</b>
60064	1m(3')	4,5	2
60081	2m(6')		
60066	1m(3')	9	3
60082	5m(15')		
60065	1m(3')	16	2



**MASTERVISION MINI REC ●**

Especificaciones técnicas / Technical specification / Détails techniques	
Longitud de inspección / <i>Inspection length</i> / <i>Longueur d'inspection</i>	1m (3') hasta 9m / <i>1m (3') up to 9m / 1m (3') jusqu'à 9m</i>
Iluminación / <i>Lighting</i> / <i>Illumination</i>	4,5mm: 4led / 5,5mm: 4led / 9mm: 4led / 16mm: 2led
Cámara estanca / <i>Waterproof camera</i> / <i>Boîtier étanche</i>	IP67
Salida de video PAL/NTSC / <i>PAL/NTSC Video output</i> / <i>Sortie vidéo PAL/NTSC</i>	●
Sistema de visión directa / <i>Direct vision system</i> / <i>Système de vision directe</i>	PAL
Conexión / <i>Connection</i> / <i>Connection</i>	mini-USB
Grabación de video y captación de foto / <i>Video recording and photographing / Enregistrement vidéo et capture de photo</i>	Micro SD 4Gb incluida (hasta 16 Gb) <i>Micro SD 4Gb included (up to 16 Gb)</i> <i>Micro SD 4Gb incluse (jusqu'à 16GB)</i>
Formato de compresión / <i>Compression format</i> / <i>Format de compression</i>	Foto-Photo JPG / AVI Video
Monitor / <i>Monitor</i> / <i>Moniteur</i>	320(RGB)x240Pixel 3,5"TFT-LCD
Dimensiones del monitor / <i>Monitor dimensions</i> / <i>Dimensions du moniteur</i>	100x70x25mm
Idiomas del menú / <i>Menu languages</i> / <i>Langues du menu</i>	10
Batería para el monitor / <i>Battery for the monitor</i> / <i>Batterie du moniteur</i>	3,7V , 1,2 Ah - Batería de litio-ión / <i>Ion-Lithium battery / Batterie en lithium-ion</i>
Tiempo de carga / <i>Charge time</i> / <i>Temps de recharge</i>	3 h
Duración de la batería / <i>Battery operation time</i> / <i>Durée de la batterie</i>	2h
Sensor de imagen / <i>Imaging sensor</i> / <i>Senseur d'image</i>	CMOS
Pixels en imagen / <i>Image pixels</i> / <i>Pixels en image</i>	704x575
Campo de visión / <i>Field of view</i> / <i>Champ de vision</i>	50°
Dimensiones de la cámara / <i>Camera dimensions</i> / <i>Dimensions de la caméra</i>	186x145x41mm
Pilas / <i>Batteries</i> / <i>Piles</i>	4x1,5V AA
Temperatura de trabajo / <i>Working temperature</i> / <i>Température de travail</i>	-10°C - 50°C / 14°F - 122°F
Regulación de la intensidad luminosa / <i>Light intensity regulation</i> <i>Régulateur de l'intensité de l'image</i>	●
Pantalla extraíble WIFI / <i>WIFI Removable screen</i> / <i>WIFI Écran extractible</i>	●
Sistema inalámbrico / <i>Wireless system</i> / <i>Système sans fil</i>	●
Maleta / <i>Case</i> / <i>Malette</i>	●
Inspección de tuberías / <i>Pipe inspection</i> / <i>Inspection de tuyauterie</i>	●
Inspección de tejados con goteras / <i>Leaking water ceiling inspection</i> / <i>Inspection de toits avec gouttières</i>	●
Inspección de muros en construcción / <i>Wall inspection while bilding</i> / <i>Inspection de murs en phase de construction</i>	●
Inspección de motores / <i>Engine inspection</i> / <i>Inspection de moteurs</i>	●
Ø fibra óptica / <i>spare camera head Ø</i> / <i>Ø fibre optique</i>	<b>cod: 60097</b> - 4,5mm / L: 1m <b>cod: 60098</b> - 4,5mm / L: 2m <b>**cod: 60071</b> - 9mm / L: 1m <b>**cod: 60088</b> - 9mm / L: 5m <b>**cod: 60070</b> - 16mm / L: 1m
Extensión 1m / <i>1m extension</i> / <i>Extension 1m</i>	<b>*cod: 60069</b>
Accesorios incluidos para la cabeza de cámara de 9mm / <i>Included spare parts for 9mm camera head</i> / <i>Accessoires inclus pour la tête de caméra de 9mm</i>	<b>cod.60075:</b> 45° espejo / <i>mirror / miroir à 45°</i> <b>cod. 60076:</b> gancho / <i>hook / crochet</i> <b>cod. 60077:</b> imán / <i>magnet / aimant</i> <b>cod. 60078:</b> protector / <i>protector / protecteur</i>
Accesorios incluidos para la cabeza de cámara de 16mm / <i>Included spare parts for 16mm camera head</i> / <i>Accessoires inclus pour la tête de caméra de 16mm</i>	<b>cod. 60072:</b> 45° espejo / <i>mirror / miroir à 45°</i> <b>cod. 60073:</b> gancho / <i>hook / crochet</i> <b>cod. 60074:</b> imán / <i>magnet / aimant</i>

\*Sólo para 60065 / *Only for 60065* / *Uniquement pour 60065*



\*\* Incluye accesorios / *Accessories included* / *Accessoires inclus*



### MASTERVISION 1



CE \*G12

COD	V	CAP		
60298	230V(50-60Hz)	Ø40-Ø200mm	1	7
60299	110V(50-60Hz)			

#### Especificaciones técnicas / Technical specification / Détails techniques

Cámara INOX / INOX camera / Boitier INOX	Ø26mm (1")
Longitud total cable / Cable total length / Longueur totale de câble	20m (66')
Barra empuje flexible / Flexible push rod / Barre de pulsion flexible	30m (100')
Inspección de tubos / Pipe inspection / Inspection de tubes	Ø40-Ø200mm
Monitor reclinable con 2m cable / Tilttable monitor with 2m cable / écran rabattable avec 2 m. de câble	960x234 Pixel 5,6"
Monitor / Monitor / Moniteur	TFT color
Baterías / Batteries / batterie	2 pcs: 12V Ni-Cd 1,2Ah
Duración de batería / Battery operation time / Durée de fonction de batterie	1,5h / bat
Cámara estanca / Waterproof camera / Boitier étanche	IP 68 - 3 bar / 30m
Salida de video integrada para grabación RCA / Video output by RCA socket for recording Sortie de video intégrée par imprimante RCA	
Maleta / Case / Malette	51 x 43 x 17 cm
Sensibilidad cámara / Required minimum illumination / Sensibilité de la caméra	0,5 Lux
Sensor luminosidad / Illumination sensor / Senseur de luminosité	1/3" COLOR CCD
Control automático de luminosidad / Automatic illumination control / Contrôle automatique de luminosité	AGC
Campo visual / Field of view / Champ visuel	120° FOV
Fuente de luz blanca / White light source / Source de lumière blanche	12 LED
Objetivo camera / Camera lens / Objectif de caméra	f=2,5mm / F=2,0
Temperatura trabajo / Working temperature / Température de travail	-28°C - 50°C / - 18°F - 122°F
Guía centradora Ø70-Ø150mm (no incluida) / Ø70-150mm centre guide (optional) Guide centreur Ø70-Ø150mm ( en option)	60318
6 cepillos de recambio para guía centradora (no incluidos) / 6 spare brushes for centre guide (optional) 6 brosses de rechange pour le guide centreur (en option)	60319
Protector de camara (no incluido) / camera protection (optional) / Protection de camera (en option)	60337
Localizador de cámara por radiofrecuencia (no incluido) / Radio-frequency camera locator (optional) Localisateur de caméra ( en option)	60336
Espejo de visión lateral (no incluido) / Side view mirror (optional) / Miroir de vision latérale (en option)	60339





**LA NUEVA MAQUINA "COMBI" PARA ROSCAR Y RANURAR TODO EN UNO**  
**THE NEW "COMBI" MACHINE FOR THREADING AND ROLL-GROOVING ALL-IN-ONE**  
**LA NOUVELLE MACHINE "COMBI" POUR FILETER ET RAINURER**

1. Ranuradora hidráulica hasta 12", para ranurados de gran calidad en tubos de acero, cobre e inoxidable.  
 Hydraulic roll groover up to 12", for getting high quality grooves in steel, copper and stainless steel pipes.  
 Rainureuse hydraulique jusqu'à 12", pour un rainurage de grande qualité des tubes acier, cuivre et inox.
2. Especialmente diseñada para trabajos a domicilio por su formato compacto, robusto y fácil de transportar.  
 This machine is specially designed for job-site work due to its compact, strong and easy to transport format.  
 Spécialement conçue pour des travaux sur chantier, grâce à sa forme compacte, robuste et facile à transporter.
3. Disponible en 2 formatos, ranuradora o roscadora, ofrece la posibilidad de convertirla de una en otra con la simple adquisición del accesorio complementario, con lo que se dispondrá de ranuradora y roscadora en una sola máquina.  
 Available in 2 formats, roll groover or threading machine, offers the possibility to transform one into the other just by acquiring the required accessory, having at your disposal threading and roll-grooving functions in only one machine.  
 Disponible en deux versions, rainureuse ou filière, elle offre la possibilité de se convertir de l'une à l'autre, simplement par acquisition des accessoires complémentaires, ce qui vous permettra de posséder les deux en une.
4. El cambio de accesorios puede realizarse en pocos segundos, siendo así la operación de ranurado mucho más fácil.  
 Any accessory change-out can be accomplished in few seconds, making grooving operation much easier.  
 Les changements d'accessoires peuvent être réalisés en quelques secondes facilitant l'opération de rainurage.



### **RANUMATIC "COMBI"**

Ranuradora hidráulica hasta 12", para ranurados de gran calidad en tubos de acero, cobre e inoxidable.

Hydraulic roll groover up to 12", for getting high quality grooves in steel, copper and stainless steel pipes.

Rainureuse hydraulique 12", pour un rainurage de grande qualité de tubes d'acier, de cuivre et d'inox.

### **ROSCAMATIC 3 "COMBI"**

Máquina roscadora de tubos hasta 3" con motor de inducción, rosca tubo de manera eficiente y segura gracias a su innovador sistema de copia.

This threading machine can thread pipes up to 3" in a safe and efficient way due to its innovative copy system.

Filière jusqu'à 3" avec un moteur à induction, fait un filetage de qualité et sûr, grâce à son système innovateur de copie.



### MÁQUINAS DE PRENSADO RADIAL / RADIAL PRESS FITTING MACHINES / MACHINES Á RACCORDS / RADIALPRESSE / MACCHINA PRESS FITTING RADIAL / MAQUINAS DE PRENSAR RADIAÍS / РАДИАЛЬНЫЕ ПРЕССПИСТОЛЕТЫ

#### PRESSMATIC MINI PORTABLE

La máquina de prensado radial Pressmatic mini Portable es compacta, manejable, ligera y portátil. El sistema de portatenazas giratoria permite acceder fácilmente a los lugares de mas difícil acceso de forma cómoda e incluso a una sola mano. La rapidez de esta maquina se ve implementada por el sistema rápido de portamordazas, que permite un cambio eficiente y seguro de mordazas, así como por el sistema de retorno automático, que elimina tiempos muertos en las operaciones de prensado.

Su batería de 14.4V, 1.65 Ah le da una larga autonomía de uso en lugares sin red eléctrica, teniendo la posibilidad de ser empleado con conexión a la red para lugares con acceso de red (accesorio opcional).

Pressmatic mini portable pressfitting machine is compact, handy, light and portable. The revolving press jaw carrying system enables jobs in difficult places, in a comfortable way even one handed. The press jaw carrying system as well as the automatic reverse system make it extremely quick and safe, saving time and making the job more efficient. The 14.4V, 1.65 Ah battery provides long autonomy in places without electricity. An optional accessory also provides an electric plug connection where electricity is available.

La machine à sertissage Radial Pressmatic mini Portable est compacte, maniable, légère et portable. Le système de porte-machoires pivotant, permet d'accéder facilement dans des coins exigüs et d'une seule main. La vitesse de cette machine est complétée para un système rapide de porte-machoires qui permet d'éviter les temps morts durant les opérations de sertissage. Sa batterie de 14.4 Volts, 1.65 Ah lui confère une grande autonomie dans les sites sans réseau électrique et peut être connectée au réseau (accessoire en option).

Consulte en las siguientes páginas qué mordaza debe seleccionar dependiendo del sistema de accesorios de prensar que vaya a emplear.

Check the following pages to make the right choice of pressing jaws depending on the pres fitting system you may use.

Consultez dans les pages suivantes, la machoire à sélectionner suivant le système d'accessoires à utiliser.



COD	V	CAP Ø	Kg.	BAT.		
60214	230V (50-60Hz)	10-40 mm	2,5	●	●	●

#### ACCESORIOS / ACCESSORIES / ACCESSOIRES / ZUBEHÖR / ACCESSORI / ACESSORIOS / ЗАПАСНЫЕ ЧАСТИ

COD	V
85005	Batería Li-Ion / Li-Ion Battery / Batterie Li-Ion 14.4V, 1.65 Ah



COD	V
85009	Cargador rápido / Quick charger / Chargeur rapide 230V (50-60Hz) 65W



COD	V
85010	Conexión / Connection / Connexion 230V (50-60Hz)



### PRESSMATIC MINI PORTABLE

#### MORDAZAS PARA PRENSADO RADIAL / RADIAL PRESS FITTING TONGUES / MACHOÏRES POUR RACCORDS / RADIALPRESSZANGEN / MORSA PER PRESS FITTING RADIAL / MANDÍBULAS PARA PRENSAR RADIAÍS / НАСАДКИ

Las mordazas de prensar EGA Master están fabricadas en acero especial forjado, con un endurecimiento especial que le confiere la máxima seguridad de prensado. Los contornos están diseñados específicamente para cada sistema de accesorios, habiendo sido mecanizados en centros de mecanizado de alta precisión, presentando así tolerancias inferiores a los realizados por microfusión, ofreciendo la máxima fiabilidad de prensado con cualquier sistema de accesorios de prensar. Se utilizan con las máquinas de prensar Pressmatic Mini. También son empleables por máquinas de otros fabricantes.

EGA Master pressing jaws are manufactured in special forging steel, being specially hardened. These features provide them with maximum working safety. Pressing contours are specifically designed for each pressing fitting system. They have been machined with high precision CNC machines, having much lower tolerances than microfusion, granting in this way maximum pressing reliability with any press fitting system. They are used with Pressmatic Mini pressfitting machines. They can also be used in other manufacturers machines.

Les machoïres à sertir Egamaster sont fabriquées à partir d'un acier forgé spécial, avec une dureté qui lui confère une sécurité de sertissage maximum. Les contours sont conçus spécifiquement pour chaque système d'accessoires, étant usinés dans des ateliers de grande précision, donnant de cette façon des tolérances inférieures à celles acquises par microfusion, garantissant le maximum de fiabilité du sertissage avec tous les systèmes d'accessoires à sertir. Les machoïres sont utilisées avec les machines à sertir Pressmatic Mini. Elles peuvent être aussi utilisées avec les machines d'autres fabricants.



Consulte en las siguientes páginas qué mordaza debe seleccionar dependiendo del sistema de accesorios de prensar que vaya a emplear.

Check the following pages to make the right choice of pressing jaws depending on the pres fitting system you may use.

Consultez dans les pages suivantes, la machoïre à sélectionner suivant le système d'accessoires à utiliser.

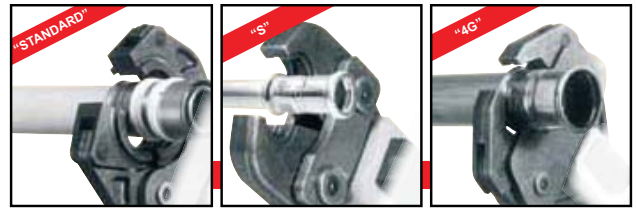

ACz		B		F		G	
H		HA		HE		K	
KI		M		MT		RFz	
RN		SA		TH		U	
UP		US		V		VAU	
VIC		VP		VX		VUS	

System	COD	Type
AC-FIX PRESS (Global Piping Systems)	51359	H 12
	51361	H 16
	51364	H 20
	51365	H 25
	51367	H 32
	51401	RFz 12
	51402	RFz 16
	51403	RFz 20
	51404	RFz 25
	51405	RFz 32
	51351	U 16
	51353	U 20
	51354	U 25
	51355	U 32
AC-FIX PRESS-MULTI (Global Piping Systems)	51422	VX 16
	51423	VX 20
	51361	H 16
	51363	H 18
	51364	H 20
	51365	H 25
	51367	H 32
	51402	RFz 16
	51403	RFz 20
ACOME MT	51404	RFz 25
	51405	RFz 32
	51351	U 16
	51352	U 18
	51353	U 20
	51354	U 25
	51355	U 32
	51445	ACz 12
AHSELL A -press elför-zinkad	51446	ACz 16
	51447	ACz 20
	51448	ACz 25
	51320	M 12
AHSELL A -press koppar	51321	M 15
	51322	M 18
	51323	M 22
	51324	M 28
AHSELL A -press rostfritt	51326	V 12
	51328	V 15
	51330	V 18
	51331	V 22
AIRBEL PRESSCLIM	51332	V 28
	51321	M 15
	51322	M 18
	51323	M 22
AIRBEL SERTINOX	51324	M 28
	51320	M 12
	51321	M 15
	51322	M 18
ALB Sistema Multicapa	51323	M 22
	51324	M 28
	51320	M 12
	51321	M 15
	51322	M 18
	51323	M 22
	51324	M 28
	51341	TH 16
	51343	TH 18
	51344	TH 20
	51346	TH 26
	APE Raccordi a pressare	51347
51361		H 16
51363		H 18
51364		H 20
51366		H 26
51367		H 32
51351		U 16
51352		U 18
51353		U 20
51357		C 26
51355		U 32
AP-Presssystem		51339
	51341	TH 16
	51343	TH 18
	51344	TH 20
	51346	TH 26
	51347	TH 32
	51350	U 14
ASTM F 1807 (Fittings with Copper Crimp Ring for PEX tubing)	51351	U 16
	51352	U 18
	51353	U 20
	51354	U 25
	51355	U 32
Bampi BALPEX (serie MP)	51417	US 3/8"
	51418	US 1/2"
	51419	US 3/4"
	51420	US 1"
	51339	TH 14
	51341	TH 16
	51343	TH 18
	51344	TH 20
BARBI MULTIPLEX (Industrial Blansol)	51346	TH 26
	51347	TH 32
	51348	TH 40
	51401	RFz 12
	51402	RFz 16
	51403	RFz 20
	51404	RFz 25
	51405	RFz 32
	51361	H 16
	51363	H 18
	51364	H 20
	BARBI MULTIPLEX (Industrial Blansol)	51361
51367		H 32
51401		RFz 12
51402		RFz 16
51403		RFz 20
51404		RFz 25
51405		RFz 32

System	COD	Type
BARBI MULTIPLEX (Industrial Blansol)	51405	RFz 32
	51361	H 16
	51363	H 18
	51364	H 20
	51361	H 26
	51367	H 32
	51391	B 14
	51392	B 16
	51393	B 18
	51394	B 20
BEGETUBE / IVAR	51395	B 26
	51396	B 32
	51402	RFz 16
	51403	RFz 20
	51404	RFz 25
BRASELI Pressfitting PE-X	51405	RFz 32
	51351	U 16
	51352	U 18
	51353	U 20
	51354	U 25
BRASELI Pressfitting Multicapa	51355	U 32
	51356	U 40
	51361	H 16
	51363	H 18
	51364	H 20
Brass Form Press Form Pex	51341	TH 16
	51343	TH 18
	51344	TH 20
	51351	U 16
	51352	U 18
Brass & Fittings RETI-PRESS	51353	U 20
	51402	RFz 16
	51447	ACz 20
	51404	RFz 25
	51405	RFz 32
BRASSTECH MULTITermoSAN Brasspress	51361	H 16
	51363	H 18
	51364	H 20
	51366	H 26
	51341	TH 16
BUCCHI tech MP	51343	TH 18
	51344	TH 20
	51346	TH 26
	51347	TH 32
	51321	M 15
Business Key MT-PRESS (inox)	51322	M 18
	51323	M 22
	51324	M 28
	51325	M 35
	51320	M 12
CHIBRO pressfitting	51321	M 15
	51322	M 18
	51323	M 22
	51324	M 28
	51320	M 12
CHIBRO pressfitting GAS	51321	M 15
	51322	M 18
	51323	M 22
	51324	M 28
	51406	SA 12
Chronimo SANHA-Niro-SanPresssystem	51407	SA 14
	51408	SA 15
	51409	SA 16
	51410	SA 18
	51411	SA 22
	51412	SA 28
	51320	M 12
	51321	M 15
	51322	M 18
	51323	M 22
	51324	M 28
	51326	V 12
CIMBERIO SpA Cimpress	51327	V 14
	51334	VG 14
	51328	V 15
	51329	V 16
	51335	VG 16
	51330	V 18
	51331	V 22
	51332	V 28
	51333	V 35
	51408	SA 15
	51410	SA 18
	51411	SA 22
51412	SA 28	
51321	M 15	
51322	M 18	
51323	M 22	
51324	M 28	
51325	M 35	
51328	V 15	
51330	V 18	
51331	V 22	
51332	V 28	
51333	V 35	
CIMBERIO SpA Cimpress Gas	51408	SA 15
	51410	SA 18
	51411	SA 22
	51412	SA 28
	51321	M 15
	51322	M 18
	51323	M 22
	51324	M 28
	51325	M 35
	51328	V 15
	51330	V 18
	51331	V 22
51332	V 28	
51333	V 35	

System	COD	Type
Climatek Clima Therm	51339	TH 14
	51341	TH 16
	51343	TH 18
	51344	TH 20
	51346	TH 26
	51347	TH 32
	51339	TH 14
	51341	TH 16
ClouSet Press	51343	TH 18
	51344	TH 20
	51346	TH 26
	51347	TH 32
	51339	TH 14
	51341	TH 16
	51343	TH 18
	51344	TH 20
Comap Sudopress Cu Visu-Control	51346	TH 26
	51326	V 12
	51327	V 14
	51328	V 15
	51329	V 16
	51330	V 18
	51331	V 22
	51332	V 28
Comap Sudopress Cu Visu-Control Gas	51327	V 14
	51328	V 15
	51329	V 16
	51330	V 18
	51331	V 22
	51332	V 28
	51327	V 14
	51328	V 15
Comap Sudopress Cu Visu-Control Solar	51329	V 16
	51330	V 18
	51331	V 22
	51332	V 28
	51327	V 14
	51328	V 15
	51329	V 16
	51330	V 18
Comap PexPress	51331	V 22
	51332	V 28
	51401	RFz 12
	51402	RFz 16
	51403	RFz 20
	51404	RFz 25
	51341	TH 16
	51344	TH 20
Comap SKINPress Visu-Control Gas	51346	TH 26
	51349	THL 32
	51339	TH 14
	51341	TH 16
	51343	TH 18
	51344	TH 20
	51346	TH 26
	51349	THL 32
Comap SKINPress Visu-Control	51341	TH 16
	51343	TH 18
	51344	TH 20
	51346	TH 26
	51349	THL 32
	51341	TH 16
	51343	TH 18
	51344	TH 20
COMISA Evo Press System	51346	TH 26
	51347	TH 32
	51360	H 14
	51361	H 16
	51363	H 18
	51364	H 20
	51366	H 26
	51367	H 32
	51391	B 14
	51392	B 16
	51393	B 18
	COMISA Evo Press System Gas	51394
51395		B 26
51396		B 32
51341		TH 16
51343		TH 18
51344		TH 20
51345		TH 25
51346		TH 26
51347		TH 32
51361		H 16
51363		H 18
CONEL CONNECT MULTI		51364
	51366	H 26
	51367	H 32
	51341	TH 16
	51344	TH 20
	51346	TH 26
	51347	TH 32
	51351	U 16
	51353	U 20
	51354	U 25 (NW 26)
	51355	U 32
	Danfoss SpeedUp FH Composite AL	51351
51353		U 20
51351		U 16
51353		U 20
51339		TH 14
51341		TH 16
Danfoss Basic FH Composite AL	51343	TH 18
	51344	TH 20
	51346	TH 26
	51347	TH 32
	51341	TH 16
	51343	TH 18
Dalpex Laser Multi Dalpex	51344	TH 20
	51346	TH 26
	51347	TH 32
	51348	TH 40
	51341	TH 16
	51343	TH 18

System	COD	Type	
Dia Norm HKS Sitec Press	51339	TH 14	
	51341	TH 16	
	51343	TH 18	
	51344	TH 20	
	51346	TH 26	
	51347	TH 32	
	51339	TH 14	
	51341	TH 16	
DIWAflex systems	51343	TH 18	
	51344	TH 20	
	51346	TH 26	
	51347	TH 32	
	51339	TH 14	
	51341	TH 16	
	51343	TH 18	
	51344	TH 20	
DUOFIL MKSYSTEM	51346	TH 26	
	51347	TH 32	
	51351	U 16	
	51352	U 18	
	51353	U 20	
	51354	U 25	
	51355	U 32	
	51351	U 16	
DW Verbundrohr multitubo systems	51352	U 18	
	51353	U 20	
	51354	U 25	
	51355	U 32	
	51321	M 15	
	51322	M 18	
	51323	M 22	
	51324	M 28	
EFFEBI PRESSTIGE	51324	M 28	
	51328	V 15	
	51330	V 18	
	51331	V 22	
	51332	V 28	
	51341	TH 16	
	51343	TH 18	
	51344	TH 20	
EFFEBI TOF MULTIPINZA	51346	TH 26	
	51347	TH 32	
	51386	F 16	
	51387	F 18	
	51388	F 20	
	51389	F 26	
	51390	F 32	
	51361	H 16	
	51363	H 18	
	51364	H 20	
	51366	H 26	
	Egeda Comisa	51367	H 32
51351		U 16	
51352		U 18	
51353		U 20	
51354		U 25	
51357		C 26	
51355		U 32	
51392		B 16	
51393		B 18	
51394		B 20	
51395		B 26	
Egeda Baronio		51396	B 32
	51341	TH 16	
	51344	TH 20	
	51346	TH 26	
	51347	TH 32	
	51326	V 12	
	51328	V 15	
	51330	V 18	
	51331	V 22	
	51332	V 28	
	Elkhart XPRESS	51428	VUS 1/2"
		51429	VUS 3/4"
51430		VUS 1"	
51431		VUS 1 1/2"	
51341		TH 16	
51344		TH 20	
EMMETI GERPEX-FIVPRESS	51346	TH 26	
	51347	TH 32	
	51392	B 16	
	51394	B 20	
	51395	B 26	
	51396	B 32	
EMPUR	51339	TH 14	
	51340	TH 15	
	51341	TH 16	
	51342	TH 17	
	51344	TH 20	
	51345	TH 25	
EUROTUBI Europa C-STAHl PRESSFITTING SISTEM	51320	M 12	
	51321	M 15	
	51322	M 18	
	51323	M 22	
	51324	M 28	
	51321	M 15	
EUROTUBI Europa INOX PRESSFITTING SISTEM	51322	M 18	
	51323	M 22	
	51324	M 28	
	51339	TH 14	
	51341	TH 16	
	51342	TH 17	
FAR Rubinetterie PRESSFAR	51344	TH 20	
	51345	TH 25	
	51346	TH 26	
	51347	TH 32	
	51348	TH 40	
	51360	H 14	
FAR Rubinetterie PRESSFAR	51361	H 16	
	51363	H 18	
	51364	H 20	
	51366	H 26	
	51367	H 32	
	51367	H 32	



System	COD	Type	
FAR Rubinetterie PRESSFAR	51350	U 14	
	51351	U 16	
	51352	U 18	
	51353	U 20	
	51354	U 25	
	51355	U 32	
	51356	U 40	
F.B.Q. BARONIO BQ press	51326	V 12	
	51327	V 14	
	51328	V 15	
	51329	V 16	
	51330	V 18	
	51331	V 22	
	51332	V 28	
F.B.Q. BARONIO BQ press carbon steel	51328	V 15	
	51330	V 18	
	51331	V 22	
F.B.Q. BARONIO BQ press Gas	51332	V 28	
	51339	TH 14	
	51341	TH 16	
FELSINEA TECH Felsineapress	51343	TH 18	
	51344	TH 20	
	51346	TH 26	
	51347	TH 32	
	51348	TH 40	
	Fercofloor DUO Press FERCO PEX	51402	RFz 16
		51403	RFz 20
51404		RFz 25	
51405		RFz 32	
51402		RFz 16	
Fercofloor DUO Press MULTIFER	51403	RFz 20	
	51404	RFz 25	
	51405	RFz 32	
	51351	U 16	
	51352	U 18	
	51353	U 20	
FILTUBE Instalpress Carbon Steel	51354	U 25	
	51355	U 32	
	51321	M 15	
	51322	M 18	
	51323	M 22	
FILTUBE Instalpress Copper	51324	M 28	
	51325	M 35	
	51321	M 15	
	51322	M 18	
	51323	M 22	
FILTUBE Instalpress Inox	51324	M 28	
	51325	M 35	
	51360	H 14	
	51361	H 16	
	51362	H 17	
Fimisol HAKAPRESS	51363	H 18	
	51364	H 20	
	51366	H 26	
	51367	H 32	
	Fittings Estándar ECO-PRESS	51402	RFz 16
51403		RFz 20	
51404		RFz 25	
51405		RFz 32	
Fittings Estándar MULTICAPA		51351	U 16
	51352	U 18	
	51353	U 20	
	51354	U 25	
	51355	U 32	
Fittings Estándar PE-X	51402	RFz 16	
	51403	RFz 20	
	51404	RFz 25	
	51405	RFz 32	
	51351	U 16	
FOHS HEIZTECHNIK FOHSPRESS	51353	U 20	
	51354	U 25	
	51355	U 32	
	51361	H 16	
	51364	H 20	
	51366	H 26	
	51367	H 32	
	51341	TH 16	
	51344	TH 20	
	51346	TH 26	
	51347	TH 32	
	51351	U 16	
FRABO FRABOPRESS RAME (Cu)	51353	U 20	
	51355	U 32	
	51326	V 12	
	51328	V 15	
	51330	V 18	
FRABO FRABOPRESS INOX 316	51331	V 22	
	51332	V 28	
	51326	V 12	
	51328	V 15	
	51330	V 18	

System	COD	Type
FRABO FRABOPRESS C-STEEL	51328	V 15
	51330	V 18
	51331	V 22
	51332	V 28
FRABO FRABOPRESS C-STEEL GAS	51328	V 15
	51330	V 18
	51331	V 22
	51332	V 28
FRABO FRABOPRESS MULTI-BRASS (MB)	51341	TH 16
	51344	TH 20
	51346	TH 26
	51347	TH 32
	51351	U 16
	51353	U 20
FRABO FRABOPRESS MULTI-PLUS (MP)	51361	H 16
	51364	H 20
	51351	U 16
	51353	U 20
FRABO SOLARPRESS	51328	V 15
	51330	V 18
	51331	V 22
	51332	V 28
Fränkische alpex-duo	51386	F 16
	51387	F 18
	51388	F 20
	51389	F 26
	51390	F 32
	51386	F 16
	51388	F 20
	51389	F 26
Fränkische alpex F50 PROFI	51390	F 32
	51361	H 16
	51364	H 20
	51366	H 26
	51367	H 32
	51341	TH 16
	51344	TH 20
	51346	TH 26
	51347	TH 32
	51351	U 16
	51353	U 20
Fränkische alpex-Gas	51354	U 25 (NW26)
	51355	U 32
	51388	F 20
	51389	F 26
FRIATHERM uni	51390	F 32
	51361	H 16
	51364	H 20
	51366	H 26
Gabo Systemtechnik	51367	H 32
	51336	TH 10
	51338	TH 12
	51339	TH 14
	51340	TH 15
	51341	TH 16
	51342	TH 17
	51343	TH 18
	51344	TH 20
	51345	TH 25
	51346	TH 26
	51347	TH 32
	GAROS	51339
51341		TH 16
51344		TH 20
51346		TH 26
51347		TH 32
51320		M 12
Geberit Mapress C-STAHN	51321	M 15
	51322	M 18
	51323	M 22
	51324	M 28
	51325	M 35
Geberit Mapress EDELSTAHL	51320	M 12
	51321	M 15
	51322	M 18
	51323	M 22
	51324	M 28
Geberit Mapress EDELSTAHL Gas	51325	M 35
	51321	M 15
	51322	M 18
	51323	M 22
	51324	M 28
Geberit Mapress KUPFER	51325	M 35
	51321	M 15
	51322	M 18
	51323	M 22
	51324	M 28
Geberit Mapress KUPFER Gas	51325	M 35
	51321	M 15
	51322	M 18
	51323	M 22
	51324	M 28
Geberit Mepla	51381	G 16
	51382	G 20
	51383	G 26
	51384	G 32
	51385	G 40
General Fittings Serie 5S00	51341	TH 16
	51343	TH 18
	51344	TH 20
	51345	TH 25
	51346	TH 26
	51347	TH 32
	51348	TH 40
	51361	H 16
	51363	H 18
	51364	H 20
	51365	H 25
	51366	H 26

System	COD	Type
General Fittings Serie 5S00	51367	H 32
	51351	U 16
	51352	U 18
	51353	U 20
	51355	U 32
	51356	U 40
	51339	TH 14
Giacomini RP Multistrato	51341	TH 16
	51342	TH 17
	51343	TH 18
	51344	TH 20
	51346	TH 26
	51349	THL 32
	51339	TH 14
Giacomini GIACOFLEX	51341	TH 16
	51342	TH 17
	51343	TH 18
	51344	TH 20
	51346	TH 26
	51349	THL 32
	51339	TH 14
Giacomini GIACOTHERM	51341	TH 16
	51342	TH 17
	51343	TH 18
	51344	TH 20
	51346	TH 26
	51349	THL 32
	51339	TH 14
Giacomini R851VT/ R850VW	51328	V 15
	51330	V 18
	51331	V 22
	51332	V 28
	51408	SA 15
	51410	SA 18
	51411	SA 22
	51412	SA 28
	51321	M 15
	51322	M 18
	51323	M 22
	Gibaco fittings COPPER C6000/B8000	51324
51320		M 12
51321		M 15
51322		M 18
51323		M 22
51324		M 28
Gibaco fittings G-Flex-Press 5900	51341	TH 16
	51344	TH 20
	51346	TH 26
	51347	TH 32
	51361	H 16
	51364	H 20
	51366	H 26
Gibaco fittings PRESS-INOX 2200	51367	H 32
	51320	M 12
	51321	M 15
	51322	M 18
	51323	M 22
	51324	M 28
Gibaco fittings PRESS-STEEL 2300	51320	M 12
	51321	M 15
	51322	M 18
	51323	M 22
	51324	M 28
	51324	M 28
Ginde Press Fitting for Ginde Multi-layer Pipe System	51351	U 16
	51353	U 20
	51354	U 25
	51355	U 32
	51341	TH 16
Global Plastic Rothapress	51343	TH 18
	51344	TH 20
	51345	TH 25
	51347	TH 32
GLOBAL TRADE Aqualpress system	51348	TH 40
	51351	U 16
	51353	U 20
	51355	U 32
Golan Pipe Systems (Scandinavia)	51351	U 16
	51353	U 20
	51354	U 25
	51355	U 32
	51339	TH 14
GS Wärmesysteme System TH	51341	TH 16
	51344	TH 20
	51346	TH 26
	51347	TH 32
GS Wärmesysteme System V	51328	V 15
	51330	V 18
	51331	V 22
	51332	V 28
GSP Group USMatrix	51341	TH 16
	51344	TH 20
	51341	TH 16
	51341	TH 16
HAKAPRESS	51358	H 11,5
	51360	H 14
	51361	H 16
	51362	H 17
	51363	H 18
	51364	H 20
	51366	H 26

System	COD	Type
HakaGerodur HAKASAN	51341	TH 16
	51344	TH 20
	51346	TH 26
	51347	TH 32
Harden 2000 Poly-Pex 2000	51339	TH 14
	51341	TH 16
	51342	TH 17
	51343	TH 18
	51344	TH 20
	51346	TH 26
	51349	THL 32
	51348	TH 40
	51339	TH 14
Harden 2000 Plastic-Press 2000	51341	TH 16
	51343	TH 18
	51344	TH 20
	51346	TH 26
	51348	TH 40
HASTINIK Chibro Pressfitting	51321	M 15
	51322	M 18
	51323	M 22
	51324	M 28
	51325	M 35
Heima-press	51341	TH 16
	51344	TH 20
	51346	TH 26
	51347	TH 32
HELIROMA kiimapress	51351	U 16
	51352	U 18
	51353	U 20
	51354	U 25
	51355	U 32
HELIROMA romapress	51356	U 40
	51402	RFz 16
	51403	RFz 20
	51404	RFz 25
	51405	RFz 32
Henco	51339	TH 14
	51341	TH 16
	51343	TH 18
	51344	TH 20
	51346	TH 26
Henco Gas	51341	TH 16
	51344	TH 20
	51346	TH 26
	51339	TH 14
Herotec Tempuss-press	51341	TH 16
	51344	TH 20
	51346	TH 26
	51347	TH 32
	51336	TH 10
Herz pipefix	51339	TH 14
	51341	TH 16
	51343	TH 18
	51344	TH 20
	51345	TH 25
	51346	TH 26
HITEC Sistema Multistrato	51347	TH 32
	51348	TH 40
	51339	TH 14
	51341	TH 16
	51343	TH 18
Hydro-Air Systems	51344	TH 20
	51347	TH 32
	51417	US 3/8"
	51418	US 1/2"
Hydro-Plumb Plus PEX	51419	US 3/4"
	51420	US 1"
	51351	U 16 (1/2")
Hydro-Air Systems	51353	U 20 (5/8")
	51354	U 25 (3/4")
	51355	U 32 (1")
	51351	U 16
	51352	U 18
IBP >B< Flex	51353	U 20
	51354	U 25
	51355	U 32
	51356	U 40
	51328	V 15
IBP >B <Press Gas	51330	V 18
	51331	V 22
	51332	V 28
	51333	V 35
	51328	V 15
IBP >B <Press Inox	51330	V 18
	51331	V 22
	51332	V 28
	51333	V 35
	51341	TH 16
IDROSANITARIA Bonomi Idropress	51343	TH 18
	51344	TH 20
	51346	TH 26
	51347	TH 32
	51348	TH 40
IDROSISTEMI Ta-Press	51341	TH 16
	51344	TH 20



System	COD	Type	
IDROSISTEMI Ta-Press	51346	TH 26	
	51347	TH 32	
	51386	F 16	
	51388	F 20	
	51389	F 26	
	51390	F 32	
	51361	H 16	
	51364	H 20	
	51366	H 26	
	51367	H 32	
	51351	U 16	
	51353	U 20	
	51355	U 32	
	51392	B 16	
	51394	B 20	
	51395	B 26	
	51396	B 32	
	IPA IPANA-Press	51336	TH 10
51337		TH 11,6	
51338		TH 12	
51339		TH 14	
51340		TH 15	
51341		TH 16	
51342		TH 17	
51343		TH 18	
51344		TH 20	
51345		TH 25	
51346		TH 26	
51439		TH 28	
51347		TH 32	
51348		TH 40	
IPALPEX (Industrie du Plastique et Accessoires)	51339	TH 14	
	51341	TH 16	
	51343	TH 18	
	51344	TH 20	
	51346	TH 26	
51349	THL 32		
IPLEX PIPELINES AUSTRALIA Iplex Pro-fit	51440	K 16/P18	
	51440	K 16/P18	
IPLEX PIPELINES AUSTRALIA Iplex K1 (Gas)	51441	K/20	
	51442	K/25	
	51443	K1/32	
IPLEX PIPELINES AUSTRALIA Iplex K2	51444	K1/40	
	51442	K/25	
ISOTUBI NUMEPRESS	51321	M 15	
	51322	M 18	
	51323	M 22	
	51324	M 28	
	51325	M 35	
IVAR ALPEX-GAS	51394	B 20	
	51395	B 26	
	51396	B 32	
IVAR MULTIPRESS	51341	TH 16	
	51343	TH 18	
	51344	TH 20	
	51346	TH 26	
	51347	TH 32	
	51386	F 16	
	51387	F 18	
	51388	F 20	
	51389	F 26	
	51390	F 32	
	51361	H 16	
	51363	H 18	
	51364	H 20	
	51366	H 26	
	51367	H 32	
	51351	U 16	
	51352	U 18	
	51353	U 20	
	51354	U 25	
	51357	C 26	
	51355	U 32	
	51392	B 16	
	51393	B 18	
	51394	B 20	
	51395	B 26	
	51396	B 32	
	IVAR IVAR-PRESS	51391	B 14
		51392	B 16
		51393	B 18
		51394	B 20
		51395	B 26
		51396	B 32
	Jäger aquapress H	51360	H 14
51361		H 16	
51362		H 17	
51363		H 18	
51364		H 20	
51366		H 26	
51367		H 32	
51356	U 40		
Jäger Niropress Typ M	51321	M 15	
	51322	M 18	
	51323	M 22	
	51324	M 28	
	51325	M 35	
Jaraflex-Presssystem	51339	TH 14	
	51341	TH 16	
	51343	TH 18	
	51344	TH 20	
	51346	TH 26	
51347	TH 32		
51348	TH 40		

System	COD	Type
JUPITER Heizsysteme	51351	U 16
	51353	U 20
	51354	U 25
KAN KAN-therm	51351	U 16
	51353	U 20
	51354	U 25
	51357	C 26
	51355	U 32
KAN KAN-therm LBP	51351	U 16
	51353	U 20
	51354	U 25
	51357	C 26
	51355	U 32
KAN KAN-therm Inox	51321	M 15
	51322	M 18
	51323	M 22
	51324	M 28
KAN KAN-therm Steel	51321	M 15
	51322	M 18
	51323	M 22
	51324	M 28
KE KELIT KELIT KELOX	51351	U 16
	51352	U 18
	51353	U 20
	51354	U 25
	51355	U 32
KE KELIT SteelFIX C-Stahl	51321	M 15
	51322	M 18
	51323	M 22
	51324	M 28
	51325	M 35
KE KELIT steelFIX Edelmetall	51321	M 15
	51322	M 18
	51323	M 22
	51324	M 28
KISAN Kisan Development (KD)	51413	KI 16
	51414	KI 20
KISAN Kisan WL	51415	KI 25
	51341	TH 16
	51344	TH 20
	51345	TH 25
	51413	KI 16
	51414	KI 20
	51415	KI 25
	51416	KI 32
	51341	TH 16
	51344	TH 20
KISAN Kisan WM	51413	KI 16
	51414	KI 20
	51415	KI 25
	51416	KI 32
KISAN Kisan WT	51413	KI 16
	51414	KI 20
KISAN Kistal C	51321	M 15
	51322	M 18
	51323	M 22
	51324	M 28
KISAN Kistal Inox	51321	M 15
	51322	M 18
	51323	M 22
	51324	M 28
KME Q-tec	51339	TH 14
	51341	TH 16
	51344	TH 20
	51346	TH 26
	51341	TH 16
	51344	TH 20
	51346	TH 26
	51347	TH 32
	51386	F 16
	51388	F 20
KLIMAT Effetto Radiante	51389	F 26
	51390	F 32
	51361	H 16
	51364	H 20
	51366	H 26
Largo-Presssystem	51367	H 32
	51351	U 16
	51353	U 20
	51354	U 25
	51355	U 32
	51392	B 16
	51394	B 20
	51395	B 26
	51396	B 32
	51338	TH 12
	51339	TH 14
	51341	TH 16
51343	TH 18	
51344	TH 20	
51346	TH 26	
51347	TH 32	
LECHAR ALCOBRAPEX	51341	TH 16
	51344	TH 20
	51346	TH 26
	51347	TH 32
LECHAR COBRAPEX	51348	TH 40
	51351	U 16
	51353	U 20
	51354	U 25
	51355	U 32

System	COD	Type
LEGEND-PRESS press fitting system	51428	VUS 1/2"
	51429	VUS 3/4"
	51430	VUS 1"
	51431	VUS 1 1/4"
LK Systems >B<-Press	51326	V 12
	51328	V 15
	51330	V 18
	51331	V 22
	51332	V 28
	51333	V 35
	51341	TH 16
LK Systems Universal	51344	TH 20
	51345	TH 25
	51347	TH 32
	51348	TH 40
	51320	M 12
Mair Heiztechnik Gomafix Cu/E	51321	M 15
	51322	M 18
	51323	M 22
Mair Heiztechnik Gomafix M	51358	H 11,5
	51360	H 14
	51361	H 16
	51364	H 20
	51358	H 11,5
Mair Heiztechnik M-Press	51360	H 14
	51361	H 16
	51364	H 20
Marpress	51367	H 32
	51322	M 18
Mark KG Polymark	51341	TH 16
	51344	TH 20
Ma.s.ter System PRESSMASTER	51346	TH 26
	51347	TH 32
	51339	TH 14
	51341	TH 16
	51343	TH 18
	51344	TH 20
	51345	TH 25
	51346	TH 26
	51347	TH 32
	51361	H 16
	51363	H 18
	51364	H 20
	51366	H 26
	51367	H 32
	51350	U 14
	MAXITUB MAXIPRESS	51401
51402		RFz 16
51403		RFz 20
51404		RFz 25
51405		RFz 32
MEGARO HAKAPRESS	51358	H 11,5
	51360	H 14
	51361	H 16
	51362	H 17
	51363	H 18
MEGARO MEGAPRESS	51364	H 20
	51366	H 26
	51367	H 32
	51392	B 16
	51394	B 20
METALGRUP PexGrup	51395	B 26
	51396	B 32
	51402	RFz 16
	51403	RFz 20
METALGRUP MultiGrup	51404	RFz 25
	51405	RFz 32
	51351	U 16
	51352	U 18
MULTITHERM PRESSSYSTEM	51353	U 20
	51354	U 25
	51355	U 32
	51341	TH 16
	51343	TH 18
	51344	TH 20
	51346	TH 26
Multicap Industrial multitubo systems MC	51347	TH 32
	51341	TH 16
	51403	RFz 16
	51404	RFz 20
	51405	RFz 32
	51361	H 16
Multicap Industrial multitubo systems MM	51364	H 20
	51365	H 25
	51366	H 26
	51367	H 32
	51351	U 16
	51352	U 18
	51353	U 20
	51354	U 25
	51355	U 32
	51341	TH 16
	51343	TH 18
	51344	TH 20
51346	TH 26	
51347	TH 32	
51402	RFz 16	
51403	RFz 20	
51404	RFz 25	
51405	RFz 32	
51361	H 16	
51364	H 20	
51365	H 25	
51366	H 26	
51367	H 32	

System	COD	Type
NEUTHERM MEKUPRESS-HT	51361	H 16
	51364	H 20
	51366	H 26
	51367	H 32
NIBCO (POL) NEXT-Heat	51361	H 16
	51364	H 20
	51365	H 25
	51367	H 32
	51341	TH 16
	51344	TH 20
	51345	TH 25
	51347	TH 32
N.T.M WINNY-AL	51351	U 16
	51353	U 20
	51354	U 25
	51355	U 32
	51339	TH 14
	51341	TH 16
	51343	TH 18
	51344	TH 20
	51346	TH 26
	51347	TH 32
	51360	H 14
	NIBCO (USA) Press System	51361
51363		H 18
51364		H 20
51366		H 26
51367		H 32
51350		U 14
51351		U 16
51352		U 18
51353		U 20
51354		U 25
51355		U 32
Nicoll Fluxo		51428
	51429	VUS 3/4"
	51430	VUS 1"
	51431	VUS 1 1/4"
	51339	TH 14
	51341	TH 16
NIROTEC PRESSFITTING	51343	TH 18
	51344	TH 20
	51346	TH 26
	51347	TH 32
	51348	TH 40
NUPIGECO Multinupi	51321	M 15
	51322	M 18
	51323	M 22
	51324	M 28
Nussbaum Cupress	51350	U 14
	51351	U 16
	51352	U 18
	51353	U 20
	51355	U 32
	51356	U 40
Nussbaum Optiflex	51326	V 12
	51328	V 15
	51330	V 18
	51331	V 22
	51332	V 28
Nussbaum Optipress	51333	V 35
	51397	VP 16
	51398	VP 20
	51399	VP 25
Nussbaum Optipress-Gas	51400	VP 32
	51328	V 15
	51330	V 18
	51331	V 22
	51332	V 28
O.M.T. Heizungssystem	51333	V 35
	51328	V 15
	51330	V 18
	51331	V 22
Oteraccordi Oter Tecno	51332	V 28
	51333	V 35
	51361	H 16
	51364	H 20
	51366	H 26
Oteraccordi Oter Tecno carbonio	51367	H 32
	51320	M 12
	51321	M 15
	51322	M 18
	51323	M 22
Oteraccordi Oter Tecno Gas	51324	M 28
	51325	M 35
	51320	M 12
	51321	M 15
	51322	M 18
Oventrop Cofit P	51323	M 22
	51324	M 28
	51325	M 35
	51369	H 16 A
	51371	H 20 A
51372	H 26 A	
51373	H 32 A	

System	COD	Type
PB TUB SERTIPRESS	51401	RFz 12
	51402	RFz 16
	51403	RFz 20
	51404	RFz 25
Pegler Yorkshire XPress Carbon	51321	M 15
	51322	M 18
	51323	M 22
	51324	M 28
	51325	M 35
Pegler Yorkshire XPress Copper	51321	M 15
	51322	M 18
	51323	M 22
	51324	M 28
	51325	M 35
Pegler Yorkshire XPress Copper Gas	51321	M 15
	51322	M 18
	51323	M 22
	51324	M 28
Pegler Yorkshire Henco Multilayer Solutions	51339	TH 14
	51341	TH 16
	51343	TH 18
	51344	TH 20
Pegler Yorkshire XPress Solar	51321	M 15
	51322	M 18
	51323	M 22
	51324	M 28
	51325	M 35
Pegler Yorkshire XPress Stainless	51321	M 15
	51322	M 18
	51323	M 22
	51324	M 28
	51325	M 35
PERFILTUBO PERFILALUPEX	51351	U 16
	51352	U 18
	51353	U 20
	51354	U 25
	51355	U 32
PERFILTUBO PERFILPRESS	51321	M 15
	51322	M 18
	51323	M 22
	51324	M 28
	51325	M 35
PEXTUBE PexTube	51402	RFz 16
	51403	RFz 20
	51404	RFz 25
	51405	RFz 32
Pietro Ravani S.p.A.	51341	TH 16
	51343	TH 18
	51344	TH 20
	51346	TH 26
	51361	H 16
PIPELIFE- RADOPRESS	51344	TH 20
	51346	TH 26
	51347	TH 32
	51361	H 16
	51364	H 20
PLASTICA ALFA Multipex	51366	H 26
	51367	H 32
	51351	U 16
	51353	U 20
	51357	C 26
PLASTICA ALFA Multipex Air	51355	U 32
	51361	H 16
	51364	H 20
	51366	H 26
	51367	H 32
PLASTICA ALFA Multipex Plus	51351	U 16
	51353	U 20
	51357	C 26
	51355	U 32
	51361	H 16
PLASTICA ALFA Multipex Thermo	51364	H 20
	51366	H 26
	51367	H 32
	51351	U 16
	51353	U 20
PLASTICA ALFA Multipex Thermo Plus	51357	C 26
	51355	U 32
	51361	H 16
	51364	H 20
	51366	H 26

System	COD	Type
PLASTICOS FERRO FERROPLAST Pressfitting PE-X	51402	RFz 16
	51403	RFz 20
	51404	RFz 25
	51405	RFz 32
PLOMYPLAS PlomyPRESS plomyAIR	51402	RFz 16
	51403	RFz 20
	51404	RFz 25
	51405	RFz 32
	51341	TH 16
	51344	TH 20
	51345	TH 25
	51347	TH 32
	51351	U 16
	51353	U 20
	51354	U 25
PLOMYPLAS plomyPRESS plomyGAS	51355	U 32
	51341	TH 16
	51344	TH 20
	51345	TH 25
PLOMYPLAS plomyPRESS plomyLAYER	51402	RFz 16
	51403	RFz 20
	51404	RFz 25
	51405	RFz 32
	51341	TH 16
	51344	TH 20
	51345	TH 25
	51347	TH 32
	51351	U 16
	51353	U 20
	51354	U 25
PLOMYPLAS plomyPRESS plomyLAYER PEX	51355	U 32
	51402	RFz 16
	51403	RFz 20
	51404	RFz 25
	51405	RFz 32
	51341	TH 16
	51344	TH 20
	51345	TH 25
	51347	TH 32
	51351	U 16
	51353	U 20
PLOMYPLAS plomyPRESS plomyPERT EVAL	51354	U 25
	51355	U 32
	51402	RFz 16
	51403	RFz 20
	51404	RFz 25
	51405	RFz 32
	51341	TH 16
	51344	TH 20
	51345	TH 25
	51347	TH 32
	PLOMYPLAS plomyPRESS plomyPEX	51351
51353		U 20
51354		U 25
51355		U 32
51402		RFz 16
51403		RFz 20
51404		RFz 25
51405		RFz 32
51341		TH 16
51344		TH 20
PLOMYPLAS plomyPRESS plomyPEX EVAL		51345
	51347	TH 32
	51351	U 16
	51353	U 20
	51354	U 25
	51355	U 32
	51402	RFz 16
	51403	RFz 20
	51404	RFz 25
	51405	RFz 32
	POLYPIPE POLYPRESS	51341
51344		TH 20
51345		TH 25
51347		TH 32
51351		U 16
51353		U 20
51354		U 25
51355		U 32
51386		F 16
51388		F 20
51389		F 26
POLYPIPE POLYSURE	51390	F 32
	51336	TH 10
	51340	TH 15
	51438	TH 22
	51439	TH 28
	51339	TH 44
	51341	TH 16
	51342	TH 17
	51343	TH 18
	51344	TH 20
	POLYSAN Handelsges. m.b.H. & Co KG (Krems/Öster-reich) POLYSAN- Press-System	51346
51349		THL 32
51348		TH 40
51321		M 15
51322		M 18
51323		M 22
51324		M 28
51325		M 35
51321		M 15
51322		M 18
POLYSAN Handelsges. m.b.H. & Co KG (Krems/Öster-reich) POLYSAN-EUROTUBI Edelstahl-Press-System		51323
	51324	M 28
	51325	M 35
	51321	M 15
	51322	M 18
	51323	M 22
	51324	M 28
	51325	M 35
	51321	M 15
	51322	M 18
	POLYSAN Handelsges. m.b.H. & Co KG (Krems/Öster-reich) POLYSAN-EUROTUBI Edelstahl-Press-System Gas	51323
51324		M 28
51325		M 35
51321		M 15
51322		M 18
51323		M 22
51324		M 28
51325		M 35
51321		M 15
51322		M 18

System	COD	Type
POLYSAN (España) Rainbow	51351	U 16
	51352	U 18
	51353	U 20
	51354	U 25
	51355	U 32
	51356	U 40
	51360	H 14
	51361	H 16
	51363	H 18
	51364	H 20
	Prandelli Mulyrama Pf	51366
51367		H 32
51361		H 16
51363		H 18
51364		H 20
51366		H 26
51367		H 32
51361		H 16
51363		H 18
51364		H 20
Prandelli Mulyrama Pfm		51366
	51367	H 32
	51341	TH 16
	51343	TH 18
	51344	TH 20
	51346	TH 26
	51347	TH 32
	51351	U 16
	51352	U 18
	51353	U 20
	PRASKI BAVARIA-press	51336
51341		TH 16
51342		TH 17
51344		TH 20
PURMO HKS Sitec Press	51346	TH 26
	51339	TH 14
	51341	TH 16
	51342	TH 17
Raccorderie Metalliche inoxPRES	51343	TH 18
	51344	TH 20
	51346	TH 26
	51347	TH 32
Raccorderie Metalliche steelPRES	51321	M 15
	51322	M 18
	51323	M 22
	51324	M 28
RBM Titafix	51321	M 15
	51322	M 18
	51323	M 22
	51324	M 28
Remo	51339	TH 14
	51341	TH 16
	51343	TH 18
	51344	TH 20
RIFENG U PRESS FITTING (F5)	51346	TH 26
	51347	TH 32
	51360	H 14
	51361	H 16
RIFENG TH PRESS FITTING (F9)	51363	H 18
	51364	H 20
	51366	H 26
	51367	H 32
RIQUIER A SERTIR	51350	U 14
	51351	U 16
	51352	U 18
	51353	U 20
Rofix Rhino PEX	51354	U 25
	51355	U 32
	51351	U 16
	51353	U 20
Roth	51355	U 32
	51344	TH 20
	51346	TH 26
	51347	TH 32
Roth Nordic Alu-LaserPlus/ PressCheck (DNK-NOR-SWE-FIN)	51344	TH 20
	51345	TH 25
	51346	TH 26
	51347	TH 32
Rubinetteria Bresciane Bonomi TURBO INOX	51379	RN 25/26
	51380	RN 32
	51321	M 15
	51322	M 18
Rubinetteria Bresciane Bonomi TURBO PRESS	51323	M 22
	51324	M 28
	51321	M 15
	51322	M 18
Rubinetteria Bresciane Bonomi TURBO PRESS	51323	M 22
	51324	M 28
	51339	TH 14
	51341	TH 16

System	COD	Type
Rubinetteria Bresciane Bonomi TURBO PRESS GAS	51341	TH 16
	51344	TH 20
	51346	TH 26
	51347	TH 32
SA.MI plastic	51339	TH 14
	51341	TH 16
	51343	TH 18
	51344	TH 20
	51346	TH 26
SANHA 3fit-Press Serie 25000	51347	TH 32
	51348	TH 40
	51339	TH 14
	51341	TH 16
	51344	TH 20
SANHA-Press Chrom Serie 16000	51346	TH 26
	51348	TH 40
	51350	U 14
	51351	U 16
	51353	U 20
SANHA-NiroSan- Presssystem Serie 9000	51355	U 32
	51356	U 40
	51406	SA 12
	51408	SA 15
	51410	SA 18
SANHA-NiroSan- Presssystem Serie 19000 (silicone free)	51411	SA 22
	51412	SA 28
	51411	SA 18
	51412	SA 22
	51411	SA 18
SANHA-NiroSan- Presssystem Gas Serie 17000	51412	SA 28
	51321	M 15
	51322	M 18
	51323	M 22
	51324	M 28
SANHA- Pressfittings Serie 6000/ Serie 8000	51325	M 35
	51326	V 12
	51327	V 14
	51334	VG 14
	51328	V 15
Rubinetteria Bresciane Bonomi TURBO PRESS	51329	V 16
	51335	VG 16
	51330	V 18
	51331	V 22
	51332	V 28
Rubinetteria Bresciane Bonomi TURBO PRESS	51333	V 35
	51408	SA 15
	51410	SA 18
	51411	SA 22
	51412	SA 28
Rubinetteria Bresciane Bonomi TURBO PRESS	51321	M 15
	51322	M 18
	51323	M 22
	51324	M 28
	51325	M 35
Rubinetteria Bresciane Bonomi TURBO PRESS	51326	V 12
	51327	V 14
	51334	VG 14
	51328	V 15
	51329	V 16

Table with columns: System, COD, Type. Rows include SANHA-Pressfittings Gas Serie 11000, SANHA-Pressfittings Solar Serie 13000, SANHA-Pressfittings Air Serie 15000, SANHA-Pressfittings Industrie Serie 18000, SANHA-PURAPRESS Serie 80000, SANHA-Therm Serie 24000.

Table with columns: System, COD, Type. Rows include Schüsser EUROPPRESS-SYSTEM, SCHÜTZ EHT rOpress, Schwer AQUApress, Seppelfricke Sudopress Cu Visu-Control, Seppelfricke Xpress copper, Seppelfricke Xpress carbon, Seppelfricke SKIN Visu-control, HENCO PRESS, SESTA Sistema multistrato, SIKO TYPRO, SIKO TYROTHERM, SLOVARM PEX-THERM, SOEMS sistema multitrato, SOEMS sistema rame e inox.

Table with columns: System, COD, Type. Rows include Standard Hidráulica MultiStandard, STELBI POLIKRAFT, SURE HISPANIA SURE-PRESS, System WELCO-Flex, System WELCO-Teck, TERMICALINE Termipex, TermoConcept TC-PRESS, TERSIA-Press, THERMAGAS Espace Espresso, THERMOLUTZ acular / rapid, THISA Thisa multipius, THISA Thisa Pex, TIEMME COBRAPRESS, TIEMME Serie 1700 PE-X a pressare, TKM Fellingsbro TKMPRESS, TRA MULTISAPER.

Table with columns: System, COD, Type. Rows include TRA TRAPRESS, Tréfimétaux Qtec, Ulrich VARIOFLEX-HAKAPRESS, UNICAL AG MAX MULTIPEX, UNIDELTA Deltail, Uponor Unipipe, Uponor MLC, Uponor MLC-D, Uponor MLC-G, Valsir PEXAL, Valsir PEXAL Gas, Vn Marcke Log. Tu-Bi-Pex, Vn Marcke Log. Tu-Bi-Press, Variotherm System TH, Viega Copatin, Viega Pexfit Fosta, Viega Pexfit Fosta G, Viega Pexfit Plus.



System	COD	Type	System	COD	Type	System	COD	Type
Viega Prestabo	51326	V 12	VSH Fitting VSH KAN-therm	51350	U 14	WeeConPress Cu Gas	51328	V 15
	51328	V 15		51351	U 16		51330	V 18
	51330	V 18		51353	U 20		51331	V 22
	51331	V 22		51354	U 25		51332	V 28
	51332	V 28		51355	U 32		51332	V 28
Viega Profipress	51333	V 35	VSH Fitting VSH Press-Carbon	51320	M 12	WeeConPress C-Stahl	51320	M 12
	51326	V 12		51321	M 15		51321	M 15
	51334	VG 14		51322	M 18 <sup>1)</sup>		51322	M 18
	51328	V 15		51323	M 22		51323	M 22
	51335	VG 16		51324	M 28 <sup>1)</sup>		51324	M 28
Viega Profipress G	51330	V 18	VSH Fitting VSH Press-Copper	51325	M 35	WeeConPress Inox	51320	M 12
	51331	V 22		51321	M 15		51321	M 15
	51332	V 28		51322	M 18 <sup>1)</sup>		51322	M 18
	51333	V 35		51323	M 22		51323	M 22
	51332	V 28		51324	M 28 <sup>1)</sup>		51324	M 28
Viega Profipress S	51326	V 12	VSH Fitting VSH Press-Copper Gas	51321	M 15	WeeConPress Inox Gas	51321	M 15
	51328	V 15		51322	M 18 <sup>1)</sup>		51322	M 22
	51330	V 18		51323	M 22		51323	M 22
	51331	V 22		51324	M 28 <sup>1)</sup>		51324	M 28
	51332	V 28		51321	M 15		51321	M 15
Viega Profipress S	51333	V 35	VSH Fitting VSH Press-Copper Solar	51322	M 18 <sup>1)</sup>	WeeConFlex MVR	51344	TH 16
	51326	V 12		51323	M 22		51344	TH 20
	51328	V 15		51324	M 28 <sup>1)</sup>		51346	TH 26
	51330	V 18		51321	M 15		51347	TH 32
	51331	V 22		51322	M 18 <sup>1)</sup>		51361	H 16
Viega Profipress S	51332	V 28	VSH Fitting VSH Press Stainless	51323	M 22	WEFA PLASTIC WETFATHERM- PRESS	51364	H 20
	51333	V 35		51324	M 28 <sup>1)</sup>		51366	H 26
	51326	V 12		51325	M 35		51367	H 32
	51328	V 15		51321	M 15		51361	H 16
	51330	V 18		51322	M 18 <sup>1)</sup>		51364	H 20
Viega Profipress Therm	51331	V 22	VSH Fitting Xpress Carbon	51323	M 22	WEM	51351	U 16
	51332	V 28		51324	M 28 <sup>1)</sup>		51339	TH 14
	51333	V 35		51325	M 35		51341	TH 16
	51326	V 12		51321	M 15		51343	TH 18
	51328	V 15		51322	M 18 <sup>1)</sup>		51344	TH 20
Viega ProPress System (USA)	51428	VUS 1/2" (OD 15,88mm)	VSH Fitting Xpress Copper	51323	M 22	WIELAND cuprotherm CTX	51344	TH 20
	51429	VUS 3/4" (OD 22,22mm)		51324	M 28 <sup>1)</sup>		51346	TH 26
	51430	VUS 1" (OD 28,58mm)		51325	M 35		51339	TH 14
	51431	VUS 1,1/4" (OD 34,93mm)		51321	M 15		51341	TH 16
	51397	VP 16		51322	M 18 <sup>1)</sup>		51343	TH 18
Viega Sanfix Fosta	51398	VP 20	VSH Fitting Xpress Copper Gas	51323	M 22	Winkler	51344	TH 20
	51399	VP 25		51324	M 28 <sup>1)</sup>		51346	TH 26
	51400	VP 32		51321	M 15		51347	TH 32
	51397	VP 16		51322	M 18 <sup>1)</sup>		51339	TH 14
	51398	VP 20		51323	M 22		51341	TH 16
Viega Sanfix Plus	51399	VP 25	VSH Fitting Xpress Copper Solar	51324	M 28 <sup>1)</sup>	WKS-Press	51342	TH 17
	51326	V 12		51321	M 15		51344	TH 20
	51328	V 15		51322	M 18 <sup>1)</sup>		51346	TH 26
	51330	V 18		51323	M 22		51347	TH 32
	51331	V 22		51324	M 28 <sup>1)</sup>		51386	F 16
Viega Sampress	51332	V 28	VSH Fitting Xpress Stainless	51325	M 35	XtraConnect	51388	F 20
	51333	V 35		51351	U 16		51388	F 20
	51326	V 12		51352	U 18		51389	F 26
	51328	V 15		51353	U 20		51390	F 32
	51330	V 18		51354	U 25		51361	H 16
Viega Sampress Inox	51331	V 22	Walter Meier Metalplast	51355	U 32	Zetaesse Multistrato EUROPEX	51364	H 20
	51332	V 28		51341	TH 16		51366	H 26
	51333	V 35		51344	TH 20		51367	H 32
	51326	V 12		51347	TH 32		51341	TH 16
	51328	V 15		51344	TH 20		51344	TH 20
Viega Sampress Inox G	51330	V 18	Watts MTR Art press	51344	TH 20	Zetaesse Multistrato EUROPEX	51346	TH 26
	51331	V 22		51346	TH 26		51347	TH 32
	51332	V 28		51347	TH 32		51351	U 16
	51339	TH 14		51417	US 3/8"		51353	U 20
	51341	TH 16		51418	US 1/2"		51353	U 20
Viessmann	51344	TH 20	WATTS RADIANT Watts WaterPEX	51419	US 3/4"	Zetaesse Multistrato EUROPEX	51355	U 32
	51346	TH 26		51420	US 1"		51339	TH 14
	51347	TH 32		51417	US 3/8"		51341	TH 16
	51341	TH 16		51418	US 1/2"		51343	TH 18
	51343	TH 18		51419	US 3/4"		51344	TH 20
V.I.Trade VI Term	51344	TH 20	WATTS RADIANT Watts RadiantPEX	51420	US 1"	Zetaesse Multistrato EUROPEX	51346	TH 26
	51345	TH 25		51351	U 16 (1/2")		51347	TH 32
	51347	TH 32		51353	U 20 (5/8")		51350	U 14
	51320	M 12		51354	U 25 (3/4")		51351	U 16
	51321	M 15		51355	U 32 (1")		51352	U 18
VSH Flow Control VSH C-Press	51322	M 18 <sup>1)</sup>	Watts RadiantPEX- AL	51350	U 14	Zetaesse Multistrato EUROPEX	51353	U 20
	51323	M 22		51351	U 16		51339	TH 14
	51324	M 28		51353	U 20		51341	TH 16
	51321	M 15		51354	U 25		51343	TH 18
	51322	M 18 <sup>1)</sup>		51355	U 32		51344	TH 20
VSH Flow Control VSH Cu-Press	51323	M 22	Wavin Tigris K1	51356	U 40	Zetaesse Multistrato ISOPEX	51346	TH 26
	51324	M 28		51350	U 14		51347	TH 32
	51321	M 15		51351	U 16		51350	U 14
	51322	M 18 <sup>1)</sup>		51353	U 20		51351	U 16
	51323	M 22		51354	U 25		51352	U 18
VSH Flow Control VSH Cu-Press Gas	51324	M 28	Wavin Tigris U1	51355	U 32	Zetaesse Multistrato ISOPEX	51353	U 20
	51321	M 15		51356	U 40		51339	TH 14
	51322	M 18 <sup>1)</sup>		51351	U 16		51341	TH 16
	51323	M 22		51353	U 20		51343	TH 18
	51324	M 28		51354	U 25		51344	TH 20
VSH Flow Control VSH Cu-Press Solar	51321	M 15	Wavin Tigris U1	51355	U 32	Zetaesse Multistrato ISOPEX	51346	TH 26
	51322	M 18 <sup>1)</sup>		51356	U 40		51347	TH 32
	51323	M 22		51350	U 14		51350	U 14
	51324	M 28		51351	U 16		51351	U 16
	51321	M 15		51353	U 20		51352	U 18
VSH Flow Control VSH Cu-Press Gas	51322	M 18 <sup>1)</sup>	Wavin K-press	51354	U 25	Zetaesse Rame HydroSAN	51353	U 20
	51323	M 22		51355	U 32		51339	TH 14
	51324	M 28		51356	U 40		51341	TH 16
	51321	M 15		51351	U 16		51344	TH 20
	51322	M 18 <sup>1)</sup>		51353	U 20		51350	U 14
VSH Flow Control VSH Cu-Press Solar	51323	M 22	Wavin TIGRIS ALUPEX	51354	U 25	Zetaesse Rame ThermoSAN	51351	U 16
	51324	M 28		51355	U 32		51353	U 20
	51321	M 15		51356	U 40		51341	TH 16
	51322	M 18 <sup>1)</sup>		51351	U 16		51344	TH 20
	51323	M 22		51353	U 20		51350	U 14
VSH Flow Control VSH KAN-therm	51324	M 28	Wavin TIGRIS BLUE	51354	U 25	ZEWOTHERM	51351	U 16
	51321	M 15		51355	U 32		51351	U 16
	51322	M 18 <sup>1)</sup>		51356	U 40		51353	U 20
	51323	M 22		51351	U 16		51341	TH 16
	51324	M 28		51353	U 20		51342	TH 17
VSH Flow Control VSH S-Press	51325	U 32	WeeConPress Cu	51354	U 25	ZURN INDUSTRIES ZURN PEX	51344	TH 20
	51321	M 15		51355	U 32		51346	TH 26
	51322	M 18 <sup>1)</sup>		51356	U 40		51347	TH 32
	51323	M 22		51326	V 12		51417	US 3/8"
	51324	M 28		51328	V 15		51418	US 1/2"

**MÁQUINAS DE PRENSADO RADIAL / RADIAL PRESS FITTING MACHINES /  
MACHINES Á RACCORDS / RADIALPRESSE / MACCHINA PRESS FITTING RADIAL /  
MAQUINAS DE PRENSAR RADIAÍS / РАДИАЛЬНЫЕ ПРЕССПИСТОЛЕТЫ**
**PRESSMATIC PORTABLE CCA**

La máquina de prensado radial Pressmatic Portable CCA es compacta, manejable, ligera y portátil. El sistema de portatenazas giratoria permite acceder fácilmente a los lugares de mas difícil acceso de forma cómoda e incluso a una sola mano. La rapidez de esta maquina se ve implementada por el sistema rápido de portamordazas, que permite un cambio eficiente y seguro de mordazas, así como por el sistema de retorno automático, que elimina tiempos muertos en las operaciones de prensado.

Su batería de 12V, 2.0 Ah le da una larga autonomía de uso en lugares sin red eléctrica, teniendo la posibilidad de ser empleado con conexión a la red para lugares con acceso de red (accesorio opcional).

Pressmatic CCA pressfitting machine is compact, handy, light and portable. The revolving press jaw carrying system enables jobs in difficult places, in a comfortable way even one handed. The press jaw carrying system as well as the automatic reverse system make it extremely quick and safe, saving time and making the job more efficient. The 12V, 2.0 Ah battery provides long autonomy in places without electricity. An optional accessory also provides an electric plug connection where electricity is available.

La machine à sertissage Radial Pressmatic Portable CCA est compacte, maniable, légère et portable. Le système de porte-machoires pivotant, permet d'accéder facilement dans des coins exigûs et d'une seule main. La vitesse de cette machine est complétée para un système rapide de porte-machoires qui permet d'éviter les temps morts durant les opérations de sertissage. Sa batterie de 12 Volts, 2.0 Ah lui confère une grande autonomie dans les sites sans réseau électrique et peut être connectée au réseau (Accessoire en option).

Consulte en las siguientes páginas qué mordaza debe seleccionar dependiendo del sistema de accesorios de prensar que vaya a emplear.

Check the following pages to make the right choice of pressing jaws depending on the pres fitting system you may use.

Consultez dans les pages suivantes, la machoire à sélectionner suivant le système d'accessoires à utiliser.



COD	V	CAP Ø	Kg	BAT.		
60196	230V (50-60Hz)	10-76 (108)	4,5	●	●	●
60197	110V (50-60Hz)					

**ACCESORIOS / ACCESSORIES / ACCESSOIRES / ZUBEHÖR / ACCESSORI / ACESSORIOS / ЗАПАСНЫЕ ЧАСТИ**

COD	V
85000	Batería / Battery / Batterie 12V, 2.0 Ah

COD	V
85001	Cargador rápido / Quick charger 230V (50-60Hz) 50W
85004	Chargeur rapide 110V (50-60Hz) 50W

COD	V
85002	Conexión / Connection / Connexion 230V (50-60Hz)



**PRESSMATIC CCA**

La máquina de prensado radial Pressmatic CCA es compacta, manejable y ligera. El sistema de portatenazas giratoria permite acceder fácilmente a los lugares de mas difícil acceso de forma cómoda e incluso a una sola mano. La rapidez de esta máquina se ve implementada por el sistema rápido de portamordazas, que permite un cambio eficiente y seguro de mordazas, así como por el sistema de retorno automático, que elimina tiempos muertos en las operaciones de prensado.

Pressmatic CCA pressfitting machine is compact, handy and light. The revolving press jaw carrying system enables jobs in difficult places, in a comfortable way even one handed. The press jaw carrying system as well as the automatic reverse system make it extremely quick and safe, saving time and making the job more efficient.

La machine de sertissage Radial Pressmatic CCA est compacte, maniable et légère. Le système porte-machoïres pivotant permet d'accéder aisément dans les coins exigüs de façon commode et d'une seule main . La rapidité de cette machine se voit confortée par un mécanisme rapide de porte-machoïres , qui permet un changement efficient et sûr des machoïres, ainsi que par le système de retour automatique qui élimine les temps morts durant les opérations de sertissage.

Consulte en las siguientes páginas qué mordaza debe seleccionar dependiendo del sistema de accesorios de prensar que vaya a emplear.

Check the following pages to make the right choice of pressing jaws depending on the pres fitting system you may use.

Consultez dans les pages suivantes, la machoïre á sélectionner suivant le système d'accessoires á utiliser.

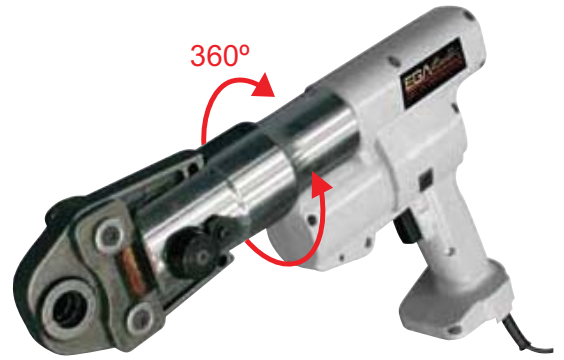

CE\*G12



COD	V	CAP $\varnothing$	Kg.	W	
60194	230V (50-60Hz)	10-76 (108)	5,0	450W	●
60195	110V (50-60Hz)				

**EGAMaster** S.A.  
ART IN INNOVATION

\*G12: GARANTIA 12 MESES / 12 MONTHS OF WARRANTY / 12 MOIS DE GARANTIE / 12 MONATEN GARANTIE / 12 MAANDEN GARANTIE / 12 MESI DI GARANZIA / 12 МЕСЯЦЕВ ГАРАНТИЯ

### PRESSMATIC PORTABLE CCA / PRESSMATIC CCA

#### MORDAZAS PARA PENSADO RADIAL / RADIAL PRESS FITTING TONGUES / MACHOÏRES POUR RACCORDS / RADIALPRESSZANGEN / MORSA PER PRESS FITTING RADIAL / MANDÍBULAS PARA PENSAR RADIAÍS / НАСАДКИ

Las mordazas de prensar EGA Master están fabricadas en acero especial forjado, con un endurecimiento especial que le confiere la máxima seguridad de prensado. Los contornos están diseñados específicamente para cada sistema de accesorios, habiendo sido mecanizados en centros de mecanizado de alta precisión, presentando así tolerancias inferiores a los realizados por microfundición, ofreciendo la máxima fiabilidad de prensado con cualquier sistema de accesorios de prensar. Se utilizan con las máquinas de prensar Pressmatic. También son empleables por máquinas de otros fabricantes.

EGA Master pressing jaws are manufactured in special forging steel, being specially hardened. These features provide them with maximum working safety. Pressing contours are specifically designed for each pressing fitting system. They have been machined with high precision CNC machines, having much lower tolerances than microfusion, granting in this way maximum pressing reliability with any press fitting system. They are used with Pressmatic pressfitting machines. They can also be used in other manufacturers machines.

Les machoïres à sertir Egamaster sont fabriquées à partir d'un acier forgé spécial, avec une dureté qui lui confère une sécurité de sertissage maximum. Les contours sont conçus spécifiquement pour chaque système d'accessoires, étant usinés dans des ateliers de grande précision, donnant de cette façon des tolérances inférieures à celles acquises par microfusion, garantissant le maximum de fiabilité du sertissage avec tous les systèmes d'accessoires à sertir. Les machoïres sont utilisées avec les machines à sertir Pressmatic. Elles peuvent être aussi utilisées avec les machines d'autres fabricants.



Consulte en las siguientes páginas qué mordaza debe seleccionar dependiendo del sistema de accesorios de prensar que vaya a emplear.

Check the following pages to make the right choice of pressing jaws depending on the pres fitting system you may use.

Consultez dans les pages suivantes, la machoïre à sélectionner suivant le système d'accessoires à utiliser.

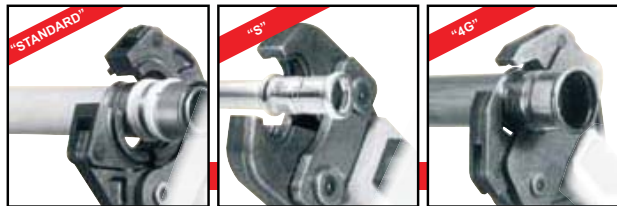

B		F		G		H	
HA		K		KI		M	
RFz		RN		SA		TH	
U		US		V		VAU	
VIC		VP		VX		VUS	



MÁQUINAS PARA TUBO / PIPING MACHINES / MACHINES POUR TUBE / ROHRBEARBEITUNGSMASCHINEN / MACCHINE PER TUBI / MÁQUINAS PARA TUBO / МАШИНЫ ДЛЯ ОБРАБОТКИ ТРУБ

System	COD	Type
AC-FIX PRESS (Global Piping System)	68328	H 12*
	68330	H 16*
	68333	H 20*
	68334	H 25*
	68336	H 32
	68229	RFZ 12*
	68406	U 16*
	68408	U 20*
	68409	U 25*
	68410	U 32
68446	VX 16*	
68447	VX 20*	
AC-FIX PRESS- MULTI (Global piping Systems)	68330	H 16*
	68332	H18*
	68333	H20*
	68334	H25*
	68336	H32
	68406	U 16*
	68407	U 18*
	68408	U 20*
AHLSELL A-press elförzinkad	68369	M 12
	68363	M 15
	68365	M 18
	68366	M 22
	68367	M 28
	68368	M 35
	68369	M 42 (4G)
	68370	M 54 (4G)
AHSELL A-press koppar	68421	V 12
	68423	V 15
	68425	V 18
	68426	V 22
	68427	V 28
	68428	V 35
	68429	V 42
	68430	V 54
AHSELL A-press rosfritt	68363	M 15
	68365	M 18
	68366	M 22
	68367	M 28
	68368	M 35
	68369	M 42 (4G)
AIRBEL PRESSCLIM	68370	M 54 (4G)
	68361	M 12
	68363	M 15
	68365	M 18
	68366	M 22
	68367	M 28
	68368	M 35
	68369	M 42 (4G)
AIRBEL SERTINOX	68370	M 54 (4G)
	68361	M 12
	68363	M 15
	68365	M 18
	68366	M 22
	68367	M 28
	68368	M 35
	68394	TH 16*
ALB Sistema Multicap	68396	TH 18*
	68397	TH 20*
	68400	TH 26*
	68401	TH 32
	68402	TH 40
	68403	TH 50(S)
	68404	TH 63(S)
	68330	H 16*
	68332	H 18*
	68333	H 20*
	68335	H 26*
	68336	H 32*
APE Raccordi a pressione	68337	H 40 (4G)
	68406	U 16*
	68407	U 18*
	68408	U 20*
	68306	C 26*
	68410	U 32
	68411	U 40
	68412	U 50
	68413	U 63 (S)
	68392	TH 14*
	68394	TH 16*
	68396	TH 18*
	68397	TH 20*
	68400	TH 26*
AP- presssystem	68401	TH 32
	68411	U 40
	68412	U 50
	68413	U 63 (63)
	68405	U 14*
	68406	U 16*
	68407	U 18*
	68408	U 20*
	68409	U 25*
	68410	U 32
	68411	U 40
	68412	U 50
ASTM F 1807 (Fittings with Copper Crimp Ring for PEX tubing)	68413	U 63 (S)
	68418	US 3/8**
	68416	US 1/2**
	68417	US 3/4**
	68415	US 1**
	68420	US 1.1/4**
	68392	TH 14*
	68394	TH 16*
	68396	TH 18*
Bampi BALPEX (serie MP)	68397	TH 20*
	68400	TH 26*
	68401	TH 32
	68402	TH 40
	68403	TH 50 (S)
	68404	TH 63 (S)

System	COD	Type
BARBI EASYPRESS	68229	RFZ 12*
	68330	H 16*
	68332	H 18*
	68333	H 20*
	68335	H 26*
	68336	H 32
	68229	RFZ 12*
	68330	H 16*
BARBI MULTIPLEX (Industrial Blansol)	68332	H 18*
	68333	H 20*
	68336	H 26*
	68411	U 40
	68412	U 50
	68413	U 63 (S)
	68300	B 14*
	BEGETUBE/IVAR	68301
68302		B 18*
68303		B 20*
68304		B 26
68305		B 32
68317		F 40
68318		F 50
68319		F 63 (S)
Beulco armatur ab VSH-press	68361	M 12
	68363	M 15
	68365	M 18
	68366	M 22
	68367	M 28
	68368	M 35
	68369	M 42 (4G)
	68370	M 54 (4G)
BRASELI Pressfitting Multicapa	68406	U 16*
	68407	U 18*
	68408	U 20*
	68409	U 25*
	68410	U 32
	68411	U 40
	68412	U 50
	68330	H 16*
Brass Form Press Form Pex	68332	H 18*
	68333	H 20*
	68394	TH 16*
	68396	TH 18*
	68397	TH 20*
	68406	U 16*
	68407	U 18*
	68408	U 20*
Brass Form Press Form Pex-Al-Pex	68330	H 16*
	68332	H 18*
	68333	H 20*
	68394	TH 16*
	68396	TH 18*
	68397	TH 20*
	68406	U 16*
	68407	U 18*
BRASSTECH MULTItermoSAN Brasspress	68408	U 20*
	68330	H 16*
	68332	H 18*
	68333	H 20*
	68335	H 26*
	68394	TH 16*
	68396	TH 18*
	68397	TH 20*
	68400	TH 26*
	68401	TH 32
	68402	TH 40
	BROEN BALLOFIX PRESS	68403
68404		TH 63 (S)
68406		U 16*
68407		U 18*
68408		U 20*
68363		M 15
68365		M 18
68366		M 22
68423		V 15
68425		V 18
68426		V 22
BUCCHI tech MP		68394
	68396	TH 18*
	68397	TH 20*
	68400	TH 26*
	68401	TH 32
	68363	M 15
	68365	M 18
	68366	M 22
Business Key MT-PRESS (inox)	68367	M 28
	68368	M 35
	68369	M 42 (4G)
	68370	M 54 (4G)
	68361	M 12
	68363	M 15
	68365	M 18
	68366	M 22
CHIBRO pressfitting Gas	68367	M 28
	68368	M 35
	68361	M 12
	68363	M 15
	68365	M 18
	68366	M 22
	68367	M 28
	68368	M 35
chronimo- SANHA-NiroSan- Presssystem	68379	SA 12
	68380	SA 14
	68381	SA 15
	68382	SA 16
	68383	SA 18

System	COD	Type		
chromimo- SANHA-NiroSan- Presssystem	68384	SA 22		
	68385	SA 28		
	68386	SA 35		
	68361	M 12		
	68363	M 15		
	68365	M 18		
	68366	M 22		
	68367	M 28		
	68368	M 35		
	68421	V 12		
	68422	V 14		
	68431	VG 14		
	68423	V 15		
	68424	V 16		
	68432	VG 16		
	68425	V 18		
	68426	V 22		
	68427	V 28		
	68428	V 35		
	68429	V 42		
	68430	V 54		
	CIMBERIO Spa Cimpres	68381	SA 15	
		68383	SA 18	
		68384	SA 22	
68385		SA 28		
68386		SA 35		
68363		M 15		
68365		M 18		
68366		M 22		
68367		M 28		
68368		M 35		
68423		V 15		
68425		V 18		
68426		V 22		
68427		V 28		
68428		V 35		
68429		V 42		
68430		V 54		
CIMBERIO Spa Cimpres Gas		68381	SA 15	
		68383	SA 18	
		68384	SA 22	
		68385	SA 28	
		68386	SA 35	
		68363	M 15	
		68365	M 18	
	68366	M 22		
	68367	M 28		
	68368	M 35		
	68423	V 15		
	68425	V 18		
	68426	V 22		
	68427	V 28		
	68428	V 35		
	68429	V 42		
	68430	V 54		
	Climatek Clima Therm	68337	H 40 (4G)	
		68392	TH 14*	
		68394	TH 16*	
		68396	TH 18*	
		68397	TH 20*	
		68400	TH 26*	
		68401	TH 32	
68348		H 40 A (4G)		
68392		TH 14*		
68394		TH 16*		
68396		TH 18*		
68397		TH 20*		
68400		TH 26*		
68401		TH 32		
ClouSet Press		68348	H 40 A (4G)	
		68392	TH 14*	
		68394	TH 16*	
		68396	TH 18*	
		68397	TH 20*	
		68400	TH 26*	
		68421	V 12	
		68422	V 14	
		68423	V 15	
		68424	V 16	
	68425	V 18		
	68426	V 22		
	68427	V 28		
	68428	V 35		
	68429	V 42		
	68430	V 54		
	Comap Sudopress Cu Visu-Control	68422	V 14	
		68423	V 15	
		68424	V 16	
		68425	V 18	
		68426	V 22	
		68427	V 28	
		68428	V 35	
		68429	V 42	
68430		V 54		
Comap Sudopress Cu Visu-Control Gas		68422	V 14	
		68423	V 15	
		68424	V 16	
		68425	V 18	
		68426	V 22	
		68427	V 28	
		68428	V 35	
		68429	V 42	
		68430	V 54	
		Comap PEXpress SKINPress Visu-Control Gas	68422	V 14
			68423	V 15
			68424	V 16
			68425	V 18
			68426	V 22
			68427	V 28
	68428		V 35	
	68429		V 42	
	68430		V 54	
	Comap SKINPress Visu-Control		68422	V 14
			68423	V 15
			68424	V 16
			68425	V 18
			68426	V 22
			68427	V 28
68428			V 35	
68429			V 42	
68430			V 54	

System	COD	Type		
COMISA Evo Press System	68394	TH 16*		
	68396	TH 18*		
	68397	TH 20*		
	68398	TH 25*		
	68400	TH 26*		
	68401	TH 32		
	68402	TH 40		
	68403	TH 50 (S)		
	68404	TH 63 (S)		
	68329	H 14*		
	68330	H 16*		
	68332	H 18*		
	68333	H 20*		
	68335	H 26*		
	68336	H 32		
	68300	B 14*		
	68301	B 16*		
	68302	B 18*		
	68303	B 20*		
	68304	B 26		
	68305	B 32		
	COMISA Evo Press System Gas	68394	TH 16*	
		68396	TH 18*	
		68397	TH 20*	
68398		TH 25*		
68400		TH 26*		
68401		TH 32		
68329		H 14*		
68330		H 16*		
68332		H 18*		
68333		H 20*		
68335		H 26*		
68336		H 32		
68300		B 14*		
68301		B 16*		
68302		B 18*		
68303		B 20*		
68304		B 26		
68305		B 32		
CONEL CONNECT MULTI		68312	F 16*	
		68314	F 20*	
		68315	F 26*	
		68316	F 32	
		68330	H 16*	
		68333	H 20*	
	68335	H 26*		
	68336	H 32		
	68300	B 14*		
	68301	B 16*		
	68302	B 18*		
	68303	B 20*		
	68304	B 26		
	68305	B 32		
	Dalpex LaserMultiDalpex	68392	TH 14*	
		68394	TH 16*	
		68396	TH 18*	
		68397	TH 20*	
		68400	TH 26*	
		68401	TH 32	
		68402	TH 40	
		68403	TH 50 (S)	
		68404	TH 63 (S)	
		Danfoss SpeedUp FH Composite al Danfoss Basic FH Composite AL	68406	U 16*
68408			U 20*	
68406			U 16*	
68408			U 20*	
68392			TH 14*	
68394			TH 16*	
68396			TH 18*	
68397			TH 20*	
68400			TH 26*	
68401			TH 32	
68402			TH 40	
DiaNorm HKS Sitec Press			68403	TH 50 (S)
			68404	TH 63 (S)
			68406	U 16*
			68407	U 18*
	68408		U 20*	
	68392		TH 14*	
	68394		TH 16*	
	68396		TH 18*	
	68397		TH 20*	
	68400		TH 26*	
	68401		TH 32	
	68402		TH 40	
	DUOFIL MKSYSYSTEM		68403	TH 50 (S)
		68404	TH 63 (S)	
		68406	U 16*	
		68407	U 18*	
		68408	U 20*	
		68409	U 25*	
		68410	U 32*	
		68406	U 16*	
		68407	U 18*	
		68408	U 20*	
		DW Verbundrohr multitubo systems	68409	U 25*
			68410	U 32
68411			U 40	
68412			U 50	
68413			U 63 (S)	
68363			M 15	
68365			M 18	
68366			M 22	
68367			M 28	
68368			M 35	
EFFEBI PRESSTIGE			68423	V 15
			68425	V 18
			68426	V 22
			68427	V 28
	68428		V 35	
	68429		V 42	
	68430		V 54	





## MÁQUINAS PARA TUBO / PIPING MACHINES / MACHINES POUR TUBE / ROHRBEARBEITUNGSMASCHINEN / MACCHINE PER TUBI / MÁQUINAS PARA TUBO / МАШИНЫ ДЛЯ ОБРАБОТКИ ТРУБ

System	COD	Type
Gibaco fittings PRESS-INOX 2200	68361	M 12
	68363	M 15
	68365	M 18
	68366	M 22
	68367	M 28
	68368	M 35
	68369	M 42 (4G)
	68370	M 54 (4G)
Gibaco fittings PRESS-STEEL 2300	68361	M 12
	68363	M 15
	68365	M 18
	68366	M 22
	68367	M 28
	68368	M 35
	68369	M 42 (4G)
	68370	M 54 (4G)
Ginde Press Fitting for Ginde Multi-layer Pipe System	68406	U 16*
	68408	U 20*
	68409	U 25*
	68410	U 32
Global plastic Rothapress	68394	TH 16*
	68396	TH 18*
	68397	TH 20*
	68398	TH 25*
	68401	TH 32
	68402	TH 40
	68403	TH 50 (S)
	68404	TH 63 (S)
GLOBAL TRADE aqualpress system	68406	U 16*
	68408	U 20*
	68409	U 25*
	68410	U 32
Golan Pipe Systems (Scandinavia) Alu-pres	68406	U 16*
	68408	U 20*
	68409	U 25*
	68410	U 32
GS Wärmesysteme System TH	68411	U 40
	68412	U 50
	68413	U 63 (S)
	68392	TH 14*
GS Wärmesysteme System V	68394	TH 16*
	68397	TH 20*
	68400	TH 26*
	68401	TH 32
	68402	TH 40
	68403	TH 50 (S)
	68404	TH 63 (S)
	68423	V 15
GSP Group USMetrix	68425	V 18
	68426	V 22
	68427	V 28
	68428	V 35
HAGOS	68394	TH 16*
	68397	TH 20*
HakaGerodur HAKAPRESS	68327	H 11.5*
	68329	H 14*
	68330	H 16*
	68331	H 17*
	68332	H 18*
	68333	H 20*
	68335	H 26*
	68336	H 32
HakaGerodur HAKASAN	68337	H 40 (4G)
	68411	U 40
	68394	TH 16*
	68397	TH 20*
	68400	TH 26*
	68401	TH 32
	68402	TH 40
	68403	TH 50 (S)
68404	TH 63 (S)	
Harden 2000 Poly-Pex 2000	68392	TH 14*
	68394	TH 16*
	68395	TH 17*
	68396	TH 18*
	68397	TH 20*
	68400	TH 26*
	68402	TH 40
	68403	TH 50 (S)
68404	TH 63 (S)	
Harden 2000 Plastic Press	68392	TH 14*
	68394	TH 16*
	68396	TH 18*
	68397	TH 20*
	68400	TH 26*
	68363	M 15
HASTINIK Chibro Pressfitting	68365	M 18
	68366	M 22
	68367	M 28
	68368	M 35
Heima-press	68394	TH 16*
	68397	TH 20*
	68400	TH 26*
	68401	TH 32
	68402	TH 40
	68403	TH 50 (S)
	68404	TH 63 (S)
	68406	U 16*
HELIROMA klimapress	68408	U 20*
	68409	U 25*
	68410	U 32
	68411	U 40
	68412	U 50
	68413	U 63 (S)

System	COD	Type
Henco	68392	TH 14*
	68394	TH 16*
	68396	TH 18*
	68397	TH 20*
	68400	TH 26*
	68349	HE 32
Henco Gas	68394	TH 16*
	68397	TH 20*
	68400	TH 26*
	68401	TH 32
Herotec Tempuss-press	68392	TH 14*
	68394	TH 16*
	68397	TH 20*
	68400	TH 26*
	68401	TH 32
	68402	TH 40
Herz Pipefix	68389	TH 10*
	68392	TH 14*
	68393	TH 15*
	68394	TH 16*
	68395	TH 17*
	68396	TH 18*
	68397	TH 20*
	68398	TH 25*
	68400	TH 26*
	68401	TH 32
	68402	TH 40
	68403	TH 50 (S)
HITEC Sistema Multistrato	68404	TH 63 (S)
	68392	TH 14*
	68394	TH 16*
	68396	TH 18*
	68397	TH 20*
	68400	TH 26*
	68401	TH 32
	68402	TH 40
	68403	TH 50 (S)
	68404	TH 63 (S)
Hydro-Air Systems Hydro-Plumb Plus Pex	68418	US 3/8**
	68416	US 1/2**
	68417	US 3/4**
	68415	US 1**
	68420	US 1.1/4**
	68406	U 16* (1/2")
Hydro-Air Systems Hydro-Flex PEX-AL-PEX	68408	U 20* (5/8")
	68409	U 25* (3/4")
	68410	U 32* (1/2")
	68421	V 12
IBP >B< press	68422	V 14
	68423	V 15
	68424	V 16
	68425	V 18
	68426	V 22
	68427	V 28
	68428	V 35
	68429	V 42
	68430	V 54
	68423	V 15
	68425	V 18
	68426	V 22
	68427	V 28
	68428	V 35
68429	V 42	
68430	V 54	
IBP >B< press Inox	68423	V 15
	68425	V 18
	68426	V 22
	68427	V 28
	68428	V 35
	68429	V 42
	68430	V 54
	68423	V 15
IBP >B< press Solar	68425	V 18
	68426	V 22
	68427	V 28
	68428	V 35
	68429	V 42
	68430	V 54
	68394	TH 16*
	68396	TH 18*
Idrosanitaria Bonomi Idropress	68397	TH 20*
	68400	TH 26*
	68401	TH 32
	68402	TH 40
	68403	TH 50 (S)
	68404	TH 63 (S)
Jäger Niropress Typ M	68394	TH 16*
	68397	TH 20*
	68400	TH 26*
	68401	TH 32
	68312	F 16*
	68314	F 20*
	68315	F 26*
	68316	F 32
	68317	F 40
	68318	F 50
Jaraflex-Presssystem	68319	F 63 (S)
	68392	TH 14*
	68394	TH 16*
	68396	TH 18*
	68397	TH 20*
	68400	TH 26*
	68401	TH 32
	68402	TH 40
JUPITER Heizsysteme	68406	U 16*
	68408	U 20*
	68409	U 25*
	68410	U 32
	68411	U 40
	68412	U 50
	68413	U 63 (S)

System	COD	Type
IPAI IPANA-Press	68389	TH 10*
	68390	TH 11.6*
	68391	TH 12*
	68392	TH 14*
	68393	TH 15*
	68394	TH 16*
	68395	TH 17*
	68396	TH 18*
	68397	TH 20*
	68398	TH 25*
	68400	TH 26*
	68401	TH 32
	68402	TH 40
	68403	TH 50 (S)
	68404	TH 63 (S)
	IPALPEX (Industrie du Plastique et Accessoires)	68392
68394		TH 16*
68396		TH 18*
68397		TH 20*
ISOLTUBEX Multicapa	68400	TH 26*
	68402	TH 40
	68403	TH 50 (S)
ISOTUBI NUMEPRESS	68404	TH 63 (S)
	68411	U 40
	68412	U 50
IVAR ALPEX-GAS	68413	U 63 (S)
	68363	M 15
	68365	M 18
	68366	M 22
IVAR MULTIPRESS	68367	M 28
	68368	M 35
	68303	B 20*
	68304	B 26
	68305	B 32
	68394	TH 16*
	68396	TH 18*
	68397	TH 20*
	68400	TH 26*
	68401	TH 32
	68312	F 16*
	68313	F 18*
	68314	F 20*
	68315	F 26*
68316	F 32	
68317	F 40	
68318	F 50	
68319	F 63 (S)	
IVAR IVAR-press	68330	H 16*
	68332	H 18*
	68333	H 20*
	68335	H 26*
	68336	H 32
	68406	U 16*
	68407	U 18*
	68408	U 20*
	68409	U 25*
	68306	C 26*
	68410	U 32*
	68301	B 16*
	68302	B 18*
	68303	B 20*
68304	B 26	
68305	B 32	
68300	B 14*	
68301	B 16*	
68302	B 18*	
68303	B 20*	
68304	B 26	
68305	B 32	
68317	F 40	
68318	F 50	
68319	F 63 (S)	
Jäger aquapress H	68329	H 14*
	68330	H 16*
	68331	H 17*
	68332	H 18*
	68333	H 20*
	68335	H 26*
	68336	H 32
	68411	U 40
	68412	U 50
	68413	U 63 (S)
	68363	M 15
	68365	M 18
	68366	M 22
	68367	M 28
68368	M 35	
68312	F 16*	
68314	F 20*	
68315	F 26*	
68316	F 32	
68317	F 40	
68318	F 50	
68319	F 63 (S)	
Jäger Niropress Typ M	68392	TH 14*
	68394	TH 16*
	68396	TH 18*
	68397	TH 20*
	68400	TH 26*
	68401	TH 32
	68402	TH 40
	68403	TH 50 (S)
	68404	TH 63 (S)
	68394	TH 16*
	68396	TH 18*
	68397	TH 20*
	68400	TH 26*
	68401	TH 32
68402	TH 40	
JUPITER Heizsysteme	68406	U 16*
	68408	U 20*
	68409	U 25*
	68410	U 32
	68411	U 40
	68412	U 50
	68413	U 63 (S)

System	COD	Type
KAN KAN-therm	68406	U 16*
	68408	U 20*
	68306	C 26
	68409	U 25*
	68410	U 32
	68411	U 40
	68403	TH 50 (S)
	68404	TH 63 (S)
KAN KAN-therm LBP	68406	U 16*
	68408	U 20*
	68409	U 25*
	68306	C 26*
	68410	U 32
	68411	U 40
	68403	TH 50 (S)
	68404	TH 63 (S)
KAN KAN-therm Steel	68363	M 15
	68365	M 18
	68366	M 22
	68367	M 28
	68368	M 35
	68369	M 42 (4G)
	68370	M 54 (4G)
	68363	M 15
KE KELIT KELIT KELOX	68365	M 18
	68366	M 22
	68367	M 28
	68368	M 35
	68369	M 42 (4G)
	68370	M 54 (4G)
	68406	U 16*
	68407	U 18*
KE KELIT steelFix C-Stahl	68408	U 20*
	68410	U 32
	68411	U 40
	68412	U 50
	68413	U 63 (S)
	68363	M 15
	68365	M 18
	68366	M 22
KE KELIT steelFix Edeldstahl	68367	M 28
	68368	M 35
	68369	M 42 (4G)
	68370	M 54 (4G)
	68363	M 15
	68365	M 18
	68366	M 22
	68367	M 28
KISAN Kisan Development (KD)	68368	M 35
	68357	KI 16*
	68358	KI 20*
	68359	KI 25*
	68394	TH 16*
	68397	TH 20*
	68398	TH 25*
	68357	KI 16*
KISAN Kisan WL	68358	KI 20*
	68359	KI 25*
	68394	TH 16*
	68397	TH 20*
	68398	TH 25*
	68357	KI 16*
	68358	KI 20*
	68359	KI 25*
KISAN Kisan WM	68394	TH 16*
	68397	TH 20*
	68398	TH 25*
	68357	KI 16*
	68358	KI 20*
	68359	KI 25*
	68363	M 15
	68365	M 18
KISAN Kistan C	68366	M 22
	68367	M 28
	68368	M 35
	68363	M 15
	68365	M 18
	68366	M 22
	68367	M 28
	68368	M 35
KISAN Kistan Inox	68363	M 15
	68365	M 18
	68366	M 22
	68367	M 28
	68368	M 35
	68392	TH 14*
	68394	TH 16*
	68397	TH 20*
KME Q -tec	68400	TH 26*
	68394	TH 16*
	68400	TH 26*
	68401	TH 32
	68312	F 16*
	68314	F 20*
	68315	F 26*
	68316	F 32
KLIMAT Effetto Radiante	68317	F 40
	68318	F 50
	68319	F 63 (S)
	68330	H 16*
	68333	H 20*
	68335	H 26*
	68336	H 32
	68406	U 16*
KISAN Kistan WL	68408	U 20*
	68409	U 25*
	68410	U 32
	68301	B 16*
	68303	B 20*
	68304	B 26
	68305	B 32

System	COD	Type
Largo-Presssystem	68391	TH 12"
	68392	TH 14"
	68394	TH 16"
	68396	TH 18"
	68397	TH 20"
	68400	TH 26"
	68401	TH 32
	68402	TH 40
	68403	TH 50 (S)
	68404	TH 63 (S)
LECHAR ALCOBRAPEX	68394	TH 16"
	68397	TH 20"
	68400	TH 26"
	68401	TH 32
LECHAR COBRAPEX	68406	U 16"
	68408	U 20"
	68409	U 25"
	68410	U 32
LEGEND-PRESS press fitting system	68442	VUS 1/2"
	68444	VUS 3/4"
	68441	VUS 1"
	68440	VUS 1. 1/4"
	68439	VUS 1.1/2"
LK Systems >B<Press	68421	V 12
	68423	V 15
	68425	V 18
	68426	V 22
	68427	V 28
	68428	V 35
	68429	V 42
	68430	V 54
	LK Systems Universal	68394
68397		TH 20"
68398		TH 25"
68401		TH 32
68402		TH 40
68403		TH 50 (S)
Mair Heiztechnik Gomafix M	68327	H 11.5"
	68329	H 14"
	68330	H 16"
	68333	H 20"
Mair Heiztechnik Gomafix CU/E	68361	M 12
	68363	M 15
	68365	M 18
	68366	M 22
Mair Heiztechnik M-Press	68327	H 11.5"
	68329	H 14"
	68330	H 16"
	68333	H 20"
	68335	H 26"
	68336	H 32
Mapress	68411	U 40
	68394	TH 16"
	68397	TH 20"
	68400	TH 26"
	68401	TH 32
	68392	TH 14"
	68394	TH 16"
	68396	TH 18"
	68397	TH 20"
	68398	TH 25"
Ma.s.ter System PRESSMASTER	68400	TH 26"
	68402	TH 40
	68403	TH 50 (S)
	68404	TH 63 (S)
	68330	H 16"
	68332	H 18"
	68333	H 20"
	68335	H 26"
	68336	H 32
	68337	H 40 (4G)
	68405	U 14"
	68406	U 16"
	68407	U 18"
	68408	U 20"
	68409	U 25"
	68410	U 32
	MAXITUB MAXIPRESS	68411
68412		U 50
68413		U 63 (S)
68374		RF 12"
68375		RF 16"
68376		RF 20"
68377		RF 25"
68327		H 11.5"
68329		H 14"
MEGARO HAKAPRESS		68330
	68331	H 17"
	68332	H 18"
	68333	H 20"
	68335	H 26"
	68336	H 32
	68337	H 40 (4G)
	68411	U 40
	68318	F 50
	68319	F 63 (S)
MEGARO MEGAPRESS	68301	B 16"
	68303	B 20"
	68304	B 26
	68305	B 32
	68317	F 40
	68318	F 50
	68319	F 63 (S)

System	COD	Type
METALGRUP MultiGrup	68406	U 16"
	68407	U 18"
	68408	U 20"
	68409	U 25"
	68410	U 32
MULTITHERM-PRESSSYSTEM	68394	TH 16"
	68396	TH 18"
	68397	TH 20"
	68400	TH 26"
	68401	TH 32
	68402	TH 40
	68403	TH 50 (S)
	68404	TH 63 (S)
	Multicap Industrial multitubo systems MC	68406
68407		U 18"
68411		U 40
68412		U 50
68413		U 63 (S)
Multicap Industrial multitubo systems MM	68406	U 16"
	68394	TH 16"
	68397	TH 20"
	68398	TH 25"
	68400	TH 26"
	68401	TH 32
	68330	H 16"
	68333	H 20"
	68334	H 25"
	68335	H 26"
NEUTHERM MEKUPRESS-HT	68336	H 32
	68337	H 40 (4G)
	68411	U 40
	68330	H 16"
	68333	H 20"
	68334	H 25"
NIBCO (POL) NEXT-Heat	68335	H 26"
	68336	H 32
	68394	TH 16"
	68397	TH 20"
	68398	TH 25"
	68401	TH 32
	68406	U 16"
	68408	U 20"
	68409	U 25"
	68410	U 32
NIBCO (USA) Press System	68442	VUS 1/2"
	68444	VUS 3/4"
	68441	VUS 1"
	68440	VUS 1. 1/4"
	68439	VUS 1.1/2"
	68443	VUS 2"
Nicoll Fluxo	68392	TH 14"
	68394	TH 16"
	68396	TH 18"
	68397	TH 20"
	68400	TH 26"
	68401	TH 32
	68402	TH 40
	68403	TH 50 (S)
	68404	TH 63 (S)
	68392	TH 14"
	68394	TH 16"
	N.T.M. WINNY-AL	68396
68397		TH 20"
68398		TH 25"
68400		TH 26"
68401		TH 32
68402		TH 40
68403		TH 50 (S)
68404		TH 63 (S)
68329		H 14"
68330		H 16"
68332		H 18"
68333		H 20"
68335		H 26"
68336	H 32	
68337	H 40 (4G)	
68405	U 14"	
68406	U 16"	
68407	U 18"	
68408	U 20"	
68409	U 25"	
68410	U 32	
68411	U 40	
68412	U 50	
68413	U 63 (S)	
NUPIPEGO Multinupi	68405	U 14"
	68406	U 16"
	68407	U 18"
	68408	U 20"
	68306	C 26"
	68410	U 32
	68411	U 40
	68412	U 50
	68413	U 63 (S)
	Nussbaum Cupress	68421
68423		V 15
68425		V 18
68426		V 22
68427		V 28
68428		V 35
68429		V 42
68430		V 54
68435		VP 16"
68436		VP 20"
Nussbaum Optiflex	68437	VP 25"
	68438	VP 32

System	COD	Type	
Nussbaum Optipress	68423	V 15	
	68425	V 18	
	68426	V 22	
	68427	V 28	
	68428	V 35	
	68429	V 42	
	68430	V 54	
	Nussbaum Optipress Gas	68423	V 15
		68425	V 18
		68426	V 22
68427		V 28	
68428		V 35	
68429		V 42	
68430		V 54	
Nussbaum Optipress-Therm		68423	V 15
		68425	V 18
		68426	V 22
	68427	V 28	
	68428	V 35	
	68429	V 42	
	68430	V 54	
	O.M.T. Heizungssystem	68330	H 16"
		68333	H 20"
		68335	H 26"
68336		H 32	
68337		H 40 (4G)	
Oteraccordi Oter Tecno		68361	M 12
	68363	M 15	
	68365	M 18	
	68366	M 22	
	68367	M 28	
	68368	M 35	
	Oteraccordi Oter Tecno carbonio	68361	M 12
		68363	M 15
		68365	M 18
		68366	M 22
68367		M 28	
68368		M 35	
Oteraccordi Oter Tecno Gas		68361	M 12
		68363	M 15
		68365	M 18
		68366	M 22
	68367	M 28	
	68368	M 35	
Oventrop Cofit P	68341	H 16 A"	
	68344	H 20 A"	
	68346	H 26 A"	
	68347	H 32 A"	
	68412	U 50	
PB TUB SERTIPRESS	68413	U 63 (S)	
	68229	RFZ 12"	
	68363	M 15	
	68365	M 18	
	68366	M 22	
	68367	M 28	
	68368	M 35	
	68363	M 15	
	68365	M 18	
	68366	M 22	
Pegler Yorkshire XPress Carbon	68367	M 28	
	68368	M 35	
	68363	M 15	
	68365	M 18	
	68366	M 22	
	68367	M 28	
	68368	M 35	
	Pegler Yorkshire XPress Copper	68363	M 15
		68365	M 18
		68366	M 22
68367		M 28	
68368		M 35	
Pegler Yorkshire XPress Copper Gas		68363	M 15
		68365	M 18
		68366	M 22
		68367	M 28
		68368	M 35
	Pegler Yorkshire Henco Multilayer Solutions	68392	TH 14"
		68394	TH 16"
		68396	TH 18"
		68397	TH 20"
		68398	TH 25"
68400		TH 26"	
68401		TH 32	
68402		TH 40	
68392		TH 14"	
68394		TH 16"	
Pegler Yorkshire XPress Solar	68396	TH 18"	
	68397	TH 20"	
	68398	TH 25"	
	68400	TH 26"	
	68401	TH 32	
	68402	TH 40	
	68392	TH 14"	
	68394	TH 16"	
	68396	TH 18"	
	Pegler Yorkshire Xpress Stainless	68397	TH 20"
68398		TH 25"	
68400		TH 26"	
68363		M 15	
68365		M 18	
68366		M 22	
68367		M 28	
68368		M 35	
PERFILTUBO PERFILALUPEX		68406	U 16"
		68407	U 18"
	68408	U 20"	
	68409	U 25"	
	68410	U 32	
	68411	U 40	
	68412	U 50	
	68413	U 63 (S)	
	PERFILTUBO PERFILPRESS	68363	M 15
		68365	M 18
68366		M 22	
68367		M 28	
68368		M 35	
68369		M 42 (4G)	
68370		M 54 (4G)	
Pietro Ravani S.p.A		68394	TH 16"
		68396	TH 18"
		68397	TH 20"
	68400	TH 26"	
	68330	H 16"	
	68332	H 18"	

System	COD	Type	
PIPELIFE RADOPRESS	68394	TH 16"	
	68396	TH 18"	
	68397	TH 20"	
	68400	TH 26"	
	68401	TH 32	
	68402	TH 40	
	68403	TH 50 (S)	
	68404	TH 63 (S)	
	PLASTICA ALFA Multypex	68330	H 16"
		68333	H 20"
68335		H 26"	
68336		H 32	
68406		U 16"	
68408		U 20"	
68306		C 26"	
68410		U 32	
PLASTICA ALFA Multypex Air		68330	H 16"
		68333	H 20"
	68335	H 26"	
	68336	H 32	
	68406	U 16"	
	68408	U 20"	
	68306	C 26"	
	68410	U 32	
	PLASTIC ALFA Multypex plus	68330	H 16"
		68333	H 20"
68335		H 26"	
68336		H 32	
68406		U 16"	
68408		U 20"	
68306		C 26"	
68410		U 32	
PLASTIC ALFA Multypex Thermo		68330	H 16"
		68333	H 20"
	68335	H 26"	
	68336	H 32	
	68406	U 16"	
	68408	U 20"	
	68306	C 26"	
	68410	U 32	
	PLASTIC ALFA Multypex Thermo Plus	68330	H 16"
		68333	H 20"
68335		H 26"	
68336		H 32	
68406		U 16"	
68408		U 20"	
68306		C 26"	
68410		U 32	
PLOMYPLAS plomyPRESS plomyAIR		68394	TH 16"
		68397	TH 20"
	68398	TH 25"	
	68401	TH 32	
	68406	U 16"	
	68408	U 20"	
	68409	U 25"	
	68410	U 32	
	PLOMYPLAS plomyPRESS plomyGAS	68394	TH 16"
		68397	TH 20"
68398		TH 25"	
68401		TH 32	
68394		TH 16"	
68397		TH 20"	
68398		TH 25"	
68401		TH 32	
PLOMYPLAS plomyPRESS plomyLAYER		68406	U 16"
		68408	U 20"
	68409	U 25"	
	68410	U 32	
	68394	TH 16"	
	68397	TH 20"	
	68398	TH 25"	
	68401	TH 32	
	PLOMYPLAS plomyPRESS plomyLAYER PEX	68406	U 16"
		68408	U 20"
68409		U 25"	
68410		U 32	
68394		TH 16"	
68397		TH 20"	
68398		TH 25"	
68401		TH 32	
PLOMYPLAS plomyPRESS plomyPERT EVAL		68406	U 16"
		68408	U 20"
	68409	U 25"	
	68410	U 32	
	68394	TH 16"	
	68397	TH 20"	
	68398	TH 25"	
	68401	TH 32	
	PLOMYPLAS plomyPRESS plomyPEX	68406	U 16"
		68408	U 20"
68409		U 25"	
68410		U 32	
68394		TH 16"	
68397		TH 20"	
68398		TH 25"	
68401		TH 32	
PLOMYPLAS plomyPRESS plomyPEX EVAL		68406	U 16"
		68408	U 20"
	68409	U 25"	
	68410	U 32	



## MÁQUINAS PARA TUBO / PIPING MACHINES / MACHINES POUR TUBE / ROHRBEARBEITUNGSMASCHINEN / MACCHINE PER TUBI / MÁQUINAS PARA TUBO / МАШИНЫ ДЛЯ ОБРАБОТКИ ТРУБ

System	COD	Type
POLYPIPE POLYPRESS	68312	F 16*
	68314	F 20*
	68315	F 26*
	68316	F 32
	68317	F 40
	68318	F 50
68319	F 63 (S)	
POLYPIPE POLYSURE	68389	TH 10*
	68393	TH 15*
POLYSAN Handelsges m.b.H & Co KG (Krems-Österreich)	68392	TH 14*
	68394	TH 16*
	68395	TH 17*
	68396	TH 18*
	68397	TH 20*
	68400	TH 26*
POLYSAN- Press-System	68401	TH 32
	68402	TH 40
	68403	TH 50 (S)
68404	TH 63 (S)	
POLYSAN Handelsges m.b.H & Co KG (Krems/Österreich)	68363	M 15
	68365	M 18
	68366	M 22
	68367	M 28
	68368	M 35
	68369	M 42 (4G)
68370	M 54 (4G)	
POLYSAN Handelsges m.b.H & Co KG (Krems/Österreich)	68363	M 15
	68365	M 18
	68366	M 22
	68367	M 28
	68368	M 35
	68369	M 42 (4G)
68370	M 54 (4G)	
POLYSAN Handelsges m.b.H & Co KG (Krems/Österreich)	68363	M 15
	68365	M 18
	68366	M 22
	68367	M 28
	68368	M 35
	68369	M 42 (4G)
68370	M 54 (4G)	
POLYSAN Handelsges m.b.H & Co KG (Krems/Österreich)	68406	U 16*
	68407	U 18*
	68408	U 20*
	68409	U 25*
	68410	U 32
	68411	U 40
68412	U 50	
68413	U 63 (S)	
Prandelli Mulyrama Pf	68329	H 14*
	68330	H 16*
	68332	H 18*
	68333	H 20*
	68335	H 26*
	68336	H 32
68411	U 40	
68412	U 50	
Prandelli Mulyrama Pfm	68330	H 16*
	68332	H 18*
	68333	H 20*
	68335	H 26*
	68336	H 32
	68394	TH 16*
68397	TH 20*	
68400	TH 26*	
68401	TH 32	
68406	U 16*	
68407	U 18*	
68408	U 20*	
PRASKI BAVARIA-press	68389	TH 10*
	68394	TH 16*
	68395	TH 17*
	68397	TH 20*
	68400	TH 26*
	68401	TH 32
68402	TH 40	
PURMO HKS Sitec Press	68392	TH 14*
	68394	TH 16*
	68395	TH 17*
	68396	TH 18*
	68397	TH 20*
	68400	TH 26*
68401	TH 32	
68402	TH 40	
Raccorderie Metalliche inoxPRES	68363	M 15
	68365	M 18
	68366	M 22
	68367	M 28
	68368	M 35
	68369	M 42 (4G)
Raccorderie Metalliche steelPRES	68363	M 15
	68365	M 18
	68366	M 22
	68367	M 28
	68368	M 35
	68369	M 42 (4G)
RBM Titafix	68392	TH 14*
	68394	TH 16*
	68396	TH 18*
	68397	TH 20*
	68400	TH 26*
	68401	TH 32
68402	TH 40	
68403	TH 50 (S)	
68404	TH 63 (S)	
Remo	68329	H 14*
	68330	H 16*
	68332	H 18*
	68333	H 20*
	68335	H 26*
	68336	H 32
68337	H 40 (4G)	

System	COD	Type
RIFENG U PRESS FITTING (F5)	68405	U 14*
	68406	U 16*
	68407	U 18*
	68408	U 20*
	68409	U 25*
	68410	U 32
68411	U 40	
68412	U 50	
68413	U 63 (S)	
RIFENG TH PRESS FITTING (F9)	68394	TH 16*
	68397	TH 20*
	68398	TH 25*
	68400	TH 26*
	68401	TH 32
	68402	TH 40
RIQUIER A SERTIR	68229	RFz 12*
Rofix Rhino Pex	68406	U 16*
	68408	U 20*
	68410	U 32
	68397	TH 20*
	68400	TH 26*
	68401	TH 32
Roth	68238	RN 17
	68239	RN 20
	68281	RN 25
	68282	RN 32
	68239	RN 20
	68281	RN 25/26
Roth Nordic Alu- LaserPlus PressCheck (DKN-NOR-SWE-FIN)	68282	RN 32
Rubinetterie Bresciane Bonomi TURBO INOX	68363	M 15
	68365	M 18
	68366	M 22
	68367	M 28
	68368	M 35
	68369	M 42 (4G)
68370	M 54 (4G)	
Rubinetterie Bresciane Bonomi TURBO STEEL	68363	M 15
	68365	M 18
	68366	M 22
	68367	M 28
	68368	M 35
	68369	M 42 (4G)
68370	M 54 (4G)	
Rubinetterie Bresciane Bonomi TURBO PRESS	68392	TH 14*
	68394	TH 16*
	68396	TH 18*
	68397	TH 20*
	68400	TH 26*
	68401	TH 32
68402	TH 40	
68403	TH 50 (S)	
68404	TH 63 (S)	
Rubinetterie Bresciane Bonomi TURBO PRESS GAS	68394	TH 16*
	68397	TH 20*
	68400	TH 26*
	68401	TH 32
	68392	TH 14*
	68394	TH 16*
68396	TH 18*	
68397	TH 20*	
68400	TH 26*	
68401	TH 32	
68402	TH 40	
68403	TH 50 (S)	
68404	TH 63 (S)	
Sa.MI plastic	68392	TH 14*
	68394	TH 16*
	68396	TH 18*
	68397	TH 20*
	68400	TH 26*
	68401	TH 32
68402	TH 40	
68403	TH 50 (S)	
68404	TH 63 (S)	
SANHA 3fit-PRESS Serie 25000	68392	TH 14*
	68394	TH 16*
	68396	TH 18*
	68397	TH 20*
	68400	TH 26*
	68401	TH 32
68402	TH 40	
68403	TH 50 (S)	
68404	TH 63 (S)	
68405	U 14*	
68406	U 16*	
68408	U 20*	
68410	U 32	
68411	U 40	
SANHA-Press Chrom Serie 16000	68379	SA 12
	68381	SA 15
	68383	SA 18
	68384	SA 22
	68385	SA 28
	68361	M 12
68363	M 15	
68365	M 18	
68366	M 22	
68367	M 28	
68421	V 12	
68423	V 15	
68425	V 18	
68426	V 22	
68427	V 28	
68428	V 35	
68429	V 42	
68430	V 54	
SANHA-NiroSan- Presssystem Serie 9000	68381	SA 15
	68383	SA 18
	68384	SA 22
	68385	SA 28
	68363	M 15
	68365	M 18
68366	M 22	
68367	M 28	
68368	M 35	
68423	V 15	
68425	V 18	
68426	V 22	
68427	V 28	
68428	V 35	
68429	V 42	
68430	V 54	

System	COD	Type
SANHA-NiroSan- Presssystem Gas Serie 17000	68381	SA 15
	68383	SA 18
	68384	SA 22
	68385	SA 28
	68386	SA 35
	68363	M 15
	68365	M 18
	68366	M 22
	68367	M 28
	68368	M 35
68423	V 15	
68425	V 18	
68426	V 22	
68427	V 28	
68428	V 35	
68429	V 42	
68430	V 54	
SANHA-NiroSan- Presssystem Serie 19000 (silicone free)	68381	SA 15
	68383	SA 18
	68384	SA 22
	68385	SA 28
	68386	SA 35
	68363	M 15
	68365	M 18
	68366	M 22
	68367	M 28
	68368	M 35
68423	V 15	
68425	V 18	
68426	V 22	
68427	V 28	
68428	V 35	
68429	V 42	
68430	V 54	
SANHA- Pressfittings Serie 6000/ Serie 8000	68379	SA 12
	68380	SA 14
	68381	SA 15
	68382	SA 16
	68383	SA 18
	68384	SA 22
	68385	SA 28
	68386	SA 35
	68361	M 12
	68363	M 15
68365	M 18	
68366	M 22	
68367	M 28	
68368	M 35	
68421	V 12	
68422	V 14	
68423	V 15	
68424	V 16	
68425	VG 14	
68426	VG 16	
68427	V 18	
68428	V 22	
68429	V 28	
68430	V 35	
SANHA- Pressfittings Gas Serie 10000/ Serie 11000	68379	SA 12
	68380	SA 14
	68381	SA 15
	68382	SA 16
	68383	SA 18
	68384	SA 22
	68385	SA 28
	68386	SA 35
	68361	M 12
	68363	M 15
68365	M 18	
68366	M 22	
68367	M 28	
68368	M 35	
68421	V 12	
68422	V 14	
68423	V 15	
68424	V 16	
68425	VG 14	
68426	VG 16	
68427	V 18	
68428	V 22	
68429	V 28	
68430	V 35	
SANHA- Pressfittings Serie 12000/ Serie 13000	68379	SA 12
	68380	SA 14
	68381	SA 15
	68382	SA 16
	68383	SA 18
	68384	SA 22
	68385	SA 28
	68386	SA 35
	68361	M 12
	68363	M 15
68365	M 18	
68366	M 22	
68367	M 28	
68368	M 35	
68421	V 12	
68423	V 15	
68425	V 18	
68426	V 22	
68427	V 28	
68428	V 35	
68429	V 42	
68430	V 54	

System	COD	Type
SANHA- Pressfittings Air Serie 14000/ Serie 15000	68379	SA 12
	68381	SA 15
	68383	SA 18
	68384	SA 22
	68385	SA 28
	68386	SA 35
	68361	M 12
	68363	M 15
	68365	M 18
	68366	M 22
68367	M 28	
68368	M 35	
68421	V 12	
68423	V 15	
68425	V 18	
68426	V 22	
68427	V 28	
68428	V 35	
68429	V 42	
68430	V 54	
SANHA- Pressfittings Industrie Serie 18000	68381	SA 15
	68383	SA 18
	68384	SA 22
	68385	SA 28
	68386	SA 35
	68361	M 12
	68363	M 15
	68365	M 18
	68366	M 22
	68367	M 28
68368	M 35	
68423	V 15	
68425	V 18	
68426	V 22	
68427	V 28	
68428	V 35	
68429	V 42	
68430	V 54	
SANHA PURAPRESS Serie 80000	68381	SA 15
	68383	SA 18
	68384	SA 22
	68385	SA 28
	68386	SA 35
	68361	M 12
	68363	M 15
	68365	M 18
	68366	M 22
	68367	M 28
68368	M 35	
68423	V 15	
68425	V 18	
68426	V 22	
68427	V 28	
68428	V 35	
68429	V 42	
68430	V 54	
SANHA-Therm Serie 24000	68379	SA 12
	68380	SA 14
	68381	SA 15
	68382	SA 16
	68383	SA 18
	68384	SA 22
	68385	SA 28
	68386	SA 35
	68361	M 12
	68363	M 15
68365	M 18	
68366	M 22	
68367	M 28	
68368	M 35	
68421	V 12	
68423	V 15	
68425	V 18	
68426	V 22	
68427	V 28	
68428	V 35	
68429	V 42	
68430	V 54	
Schlösser EUROPRESS- SYSTEM	68394	TH 16*
	68397	TH 20*
	68400	TH 26*
	68401	TH 32
	68392	TH 14*
	68394	TH 16*
SCHÜTZ EHT rOpress	68397	TH 20*
	68400	TH 26*
	68401	TH 32
	68402	TH 40
	68361	M 12
	68363	M 15
Schwer AQUApress	68365	M 18
	68366	M 22
	68367	M 28
	68368	M 35
	68369	M 42 (4G)
	68370	M 54 (4G)
68421	V 12	
68423	V 15	
68425	V 18	
68426	V 22	
68427	V 28	
68428	V 35	
68429	V 42	
68430	V 54	
Seppelfrickle Sudopress Cu Visu-Control	68423	V 15
	68425	V 18
	68426	V 22
	68427	V 28
	68428	V 35
	68429	V 42
68430	V 54	
Seppelfrickle Sudopress Cu Visu-Control Gas	68423	V 15
	68425	V 18
	68426	V 22
	68427	V 28
	68428	V 35
	68429	V 42
68430	V 54	

System	COD	Type
Seppelfrickle	68423	V 15
Sudopress Cu	68425	V 18
Visu-Control Solar	68426	V 22
	68361	M 12
	68363	M 15
Seppelfrickle	68365	M 18
XPress copper	68366	M 22
	68367	M 28
	68368	M 35
	68363	M 15
Seppelfrickle	68365	M 18
XPress copper	68366	M 22
Gas	68367	M 28
	68368	M 35
	68363	M 15
	68365	M 18
Seppelfrickle	68366	M 22
XPress	68367	M 28
stainless	68368	M 35
	68369	M 42 (4G)
	68370	M 54 (4G)
	68361	M 12
	68363	M 15
	68365	M 18
Seppelfrickle	68366	M 22
XPress carbon	68367	M 28
	68368	M 35
	68369	M 42 (4G)
	68370	M 54 (4G)
	68392	TH 14*
	68394	TH 16*
Seppelfrickle	68396	TH 18*
Sudopress SKIN	68397	TH 20*
Visu-control	68402	TH 40
	68403	TH 50 (S)
	68404	TH 63 (S)
Seppelfrickle	68394	TH 16*
HENCO PRESS	68397	TH 20*
	68400	TH 26*
	68330	H 16*
	68333	H 20*
	68392	TH 14*
	68394	TH 16*
	68396	TH 18*
SESTA	68397	TH 20*
Sistema	68400	TH 26*
multistrato	68401	TH 32
	68402	TH 40
	68403	TH 50 (S)
	68404	TH 63 (S)
	68406	U 16*
	68408	U 20*
	68392	TH 14*
	68394	TH 16*
SIKO TYPRO	68396	TH 18*
	68397	TH 20*
	68400	TH 26*
	68392	TH 14*
	68394	TH 16*
SIKO	68396	TH 18*
TYROTHERM	68397	TH 20*
	68400	TH 26*
	68406	U 16*
	68408	U 20*
	68335	H 26*
SLOVARM	68410	U 32
PEX-THERM	68330	H 16*
	68333	H 20*
	68336	H 32
	68392	TH 14*
	68394	TH 16*
	68396	TH 18*
	68397	TH 20*
SOEMS	68400	TH 26*
sistema	68401	TH 32
multistrato	68402	TH 40
	68403	TH 50 (S)
	68404	TH 63 (S)
	68421	V 12
	68423	V 15
	68425	V 18
SOEMS	68426	V 22
sistema rame e	68427	V 28
inox	68428	V 35
	68429	V 42
	68430	V 54
	68406	U 16*
	68407	U 18*
	68408	U 20*
Standars	68409	U 25*
Hidraulica	68410	U 32
MultiStandard	68411	U 40
	68412	U 50
	68413	U 63 (S)
	68392	TH 14*
	68394	TH 16*
	68396	TH 18*
STELBI	68397	TH 20*
POLIKRAFT	68400	TH 26*
	68401	TH 32
	68402	TH 40
	68403	TH 50 (S)
	68404	TH 63 (S)

System	COD	Type
	68340	H 14 A*
	68341	H 16 A*
	68342	H 17 A*
System	68344	H 20 A*
WELCO-Flex	68346	H 26 A*
	68347	H 32 A*
	68348	H 40 A (4G)
	68341	H 16 A*
System	68344	H 20 A*
WELCO-Teck	68346	H 26 A*
	68301	B 16*
	68303	B 20*
	68304	B 26
	68305	B 32
	68330	H 16*
TERMICALINE	68333	H 20*
Termipex	68394	TH 16*
	68397	TH 20*
	68400	TH 26*
	68401	TH 32
	68406	U 16*
	68408	U 20*
	68405	U 14*
	68406	U 16*
	68407	U 18*
	68408	U 20*
	68409	U 25*
	68410	U 32
	68411	U 40
	68412	U 50
	68413	U 63 (S)
	68329	H 14*
	68394	TH 16*
	68397	TH 20*
	68400	TH 26*
	68401	TH 32
	68402	TH 40
	68329	H 14*
	68330	H 16*
	68331	H 17*
	68406	U 16*
	68407	U 18*
	68408	U 20*
	68409	U 25*
	68410	U 32
	68411	U 40
	68406	U 16*
	68408	U 20*
	68409	U 25*
	68410	U 32
	68392	TH 14*
	68394	TH 16*
	68396	TH 18*
	68397	TH 20*
	68400	TH 26*
	68401	TH 32
	68402	TH 40
	68329	H 14*
	68330	H 16*
	68331	H 17*
	68406	U 16*
	68407	U 18*
	68408	U 20*
	68409	U 25*
	68410	U 32
	68411	U 40
	68392	TH 14*
	68394	TH 16*
	68396	TH 18*
	68397	TH 20*
	68400	TH 26*
	68401	TH 32
	68402	TH 40
	68329	H 14*
	68330	H 16*
	68331	H 17*
	68406	U 16*
	68407	U 18*
	68408	U 20*
	68409	U 25*
	68410	U 32
	68411	U 40
	68392	TH 14*
	68394	TH 16*
	68396	TH 18*
	68397	TH 20*
	68400	TH 26*
	68401	TH 32
	68402	TH 40
	68329	H 14*
	68330	H 16*
	68331	H 17*
	68406	U 16*
	68407	U 18*
	68408	U 20*
	68409	U 25*
	68410	U 32
	68411	U 40
	68412	U 50
	68328	H 12*
	68330	H 16*
	68333	H 20*
	68334	H 25*
	68336	H 32
	68229	RFZ 12*
	68392	TH 14*
	68394	TH 16*
	68397	TH 20*
	68329	H 14*
	68330	H 16*
	68331	H 17*
	68332	H 18*
	68333	H 20*
	68335	H 26*
	68336	H 32
	68337	H 40 (4G)
	68406	U 16*
	68408	U 20*
	68335	H 26*
	68410	U 32
	68392	TH 14*
	68394	TH 16*
	68396	TH 18*
	68397	TH 20*
	68400	TH 26*
	68401	TH 32
	68402	TH 40
	68403	TH 50 (S)
	68404	TH 63 (S)
	68329	H 14*
	68330	H 16*
	68332	H 18*
	68333	H 20*
	68335	H 26*
	68336	H 32
	68337	H 40 (4G)
	68406	U 16*
	68408	U 20*
	68335	H 26*
	68410	U 32
	68392	TH 14*
	68394	TH 16*
	68396	TH 18*
	68397	TH 20*
	68400	TH 26*
	68401	TH 32
	68402	TH 40
	68403	TH 50 (S)
	68404	TH 63 (S)
	68329	H 14*
	68330	H 16*
	68332	H 18*
	68333	H 20*

System	COD	Type
	68335	H 26*
	68336	H 32
	68337	H 40 (4G)
	68405	U 14*
	68406	U 16*
UNIDELTA	68407	U 18*
Deltall	68408	U 20*
	68410	U 32
	68411	U 40
	68412	U 50
	68413	U 63 (S)
	68405	U 14*
	68406	U 16*
	68407	U 18*
	68408	U 20*
	68410	U 32
	68411	U 40
	68412	U 50
	68413	U 63 (S)
	68411	U 40
	68412	U 50
	68413	U 63 (S)
	68411	U 40
	68412	U 50
	68413	U 63 (S)
	68329	H 14*
	68330	H 16*
	68333	H 20*
	68329	H 14*
	68330	H 16*
	68333	H 20*
	68335	H 26*
	68394	TH 16*
	68396	TH 18*
	68397	TH 20*
	68400	TH 26*
	68401	TH 32
	68402	TH 40
	68394	TH 16*
	68396	TH 18*
	68397	TH 20*
	68400	TH 26*
	68401	TH 32
	68402	TH 40
	68361	M 12
	68363	M 15
	68365	M 18
	68366	M 22
	68367	M 28
	68368	M 35
	68369	M 42 (4G)
	68370	M 54 (4G)
	68421	V 12
	68423	V 15
	68425	V 18
	68426	V 22
	68427	V 28
	68428	V 35
	68429	V 42
	68430	V 54
	68446	VX 16*
	68447	VX 20*
	68446	VX 16*
	68447	VX 20*
	68445	VX 12*
	68446	VX 16*
	68447	VX 20*
	68421	V 12
	68423	V 15
	68425	V 18
	68426	V 22
	68427	V 28
	68428	V 35
	68429	V 42
	68430	V 54
	68421	V 12
	68423	V 15
	68425	V 18
	68426	V 22
	68427	V 28
	68428	V 35
	68429	V 42
	68430	V 54
	68421	V 12
	68423	V 15
	68425	V 18
	68426	V 22
	68427	V 28
	68428	V 35
	68429	V 42
	68430	V 54
	68421	V 12
	68423	V 15
	68425	V 18
	68426	V 22
	68427	V 28
	68428	V 35
	68429	V 42
	68430	V 54

System	COD	Type
	68421	V 12
	68423	V 15
	68425	V 18
	68426	V 22
	68442	VUS 1/2"
	68444	VUS 3/4"
	68441	VUS 1"
	68440	VUS 1. 1/4"
	68439	VUS 1. 1/2"
	68443	VUS 2"
	68435	VP 16*
	68436	VP 20*
	68437	VP 25*
	68438	VP 32*
	68435	VP 16*
	68436	VP 20*
	68421	V 12
	68423	V 15
	68425	V 18
	68426	V 22
	68427	V 28
	68428	V 35
	68429	V 42
	68430	V 54
	68423	V 15
	68425	V 18
	68426	V 22
	68427	V 28
	68428	V 35
	68429	V 42
	68430	V 54
	68392	TH 14*
	68394	TH 16*
	68397	TH 20*
	68400	TH 26*
	68401	TH 32
	68402	TH 40
	68394	TH 16*
	68396	TH 18*
	68397	TH 20*
	68398	TH 25*
	68401	TH 32
	68361	M 12
	68363	M 15
	68365	M 18
	68366	M 22
	68367	M 28
	68368	M 35
	68369	M 42 (4G)
	68370	M 54 (4G)
	68363	M 15
	68365	M 18
	68366	M 22
	68367	M 28
	68368	M 35
	68369	M 42 (4G)
	68370	M 54 (4G)
	68363	M 15
	68365	M 18
	68366	M 22
	68367	M 28
	68368	M 35
	68369	M 42 (4G)
	68370	M 54 (4G)
	68405	U 14*
	68406	U 16*

## MÁQUINAS PARA TUBO / PIPING MACHINES / MACHINES POUR TUBE / ROHRBEARBEITUNGSMASCHINEN / MACCHINE PER TUBI / MÁQUINAS PARA TUBO / МАШИНЫ ДЛЯ ОБРАБОТКИ ТРУБ

System	COD	Type
VSH Fittings	68363	M 15
	68365	M 18
VSH Press	68366	M 22
Copper Solar	68367	M 28
	68368	M 35
	68363	M 15
	68365	M 18
VSH Fittings	68366	M 22
VSH Press	68367	M 28
Stainless	68368	M 35
	68369	M 42 (4G)
	68370	M 54 (4G)
	68361	M 12
	68363	M 15
VSH Fittings	68365	M 18
Xpress	68366	M 22
Carbon	68367	M 28
	68368	M 35
	68369	M 42 (4G)
	68370	M 54 (4G)
	68363	M 15
VSH Fittings	68365	M 18
Xpress	68366	M 22
Copper	68367	M 28
	68368	M 35
	68363	M 15
VSH Fittings	68365	M 18
Xpress	68366	M 22
Copper Gas	68367	M 28
	68368	M 35
	68363	M 15
VSH Fittings	68365	M 18
Xpress	68366	M 22
Copper Solar	68367	M 28
	68368	M 35
	68363	M 15
VSH Fittings	68365	M 18
Xpress	68366	M 22
Stainless	68367	M 28
	68368	M 35
	68369	M 42 (4G)
	68370	M 54 (4G)
	68406	U 16*
	68407	U 18*
Walter Meier	68408	U 20*
Metalplast	68409	U 25*
	68410	U 32
	68411	U 40
	68412	U 50
	68413	U 63 (S)
Watts MTR	68394	TH 16*
Art Press	68397	TH 20*
	68400	TH 26*
	68401	TH 32
	68418	US 3/8**
WATTS MTR	68416	US 1/2**
RADIANT	68417	US 3/4**
Watts WaterPEX	68415	US 1**
	68420	US 1.1/4**
	68418	US 3/8**
WATTS	68416	US 1/2**
RADIANT	68417	US 3/4**
Watts	68415	US 1**
RadiantPEX	68420	US 1.1/4**
	68406	U 16 (1/2")
WATTS	68408	U 20 (5/8")
RADIANT	68409	U 25 (3/4")
Watts	68410	U 32 (1")
RadiantPEX-AL	68405	U 14*
	68406	U 16*
	68408	U 20*
Wavin	68409	U 25*
Tigris K1	68410	U 32
	68411	U 40
	68412	U 50
	68405	U 14*
	68406	U 16*
Wavin	68408	U 20*
Tigris M1	68409	U 25*
	68410	U 32
	68411	U 40
	68412	U 50
	68406	U 16*
Wavin	68408	U 20*
K-press	68409	U 25*
	68410	U 32
	68411	U 40
	68412	U 50
	68406	U 16*
Wavin	68408	U 20*
TIGRIS ALUPEX	68409	U 25*
	68410	U 32
	68411	U 40
	68412	U 50
	68406	U 16*
Wavin	68408	U 20*
TIGRIS BLUE	68409	U 25*
	68410	U 32
	68411	U 40
	68412	U 50
	68421	V 12
	68423	V 15
WeeConPress	68425	V 18
Cu	68426	V 22
	68427	V 28
	68428	V 35
	68429	V 42
	68430	V 54
	68423	V 15
	68425	V 18
WeeConPress	68426	V 22
Cu Gas	68427	V 28
	68428	V 35
	68429	V 42
	68430	V 54

System	COD	Type
	68361	M 12
	68363	M 15
WeeConPress	68365	M 18
C-Stahl	68366	M 22
	68367	M 28
	68368	M 35
	68369	M 42 (4G)
	68370	M 54 (4G)
	68361	M 12
	68363	M 15
WeeConPress	68365	M 18
Inox	68366	M 22
	68367	M 28
	68368	M 35
	68369	M 42 (4G)
	68370	M 54 (4G)
	68363	M 15
WeeConPress	68365	M 18
Inox Gas	68366	M 22
	68367	M 28
	68368	M 35
	68394	TH 16*
WeeConFlex	68397	TH 20*
MVR	68400	TH 26*
	68401	TH 32
	68402	TH 40
	68403	TH 50 (S)
	68404	TH 63 (S)
WEFA PLASTIC	68330	H 16*
WEFATHERM-	68333	H 20*
PRESS	68335	H 26*
	68336	H 32
WEM	68330	H 16*
	68406	U 16*
WIELAND	68392	TH 14*
cuprotherm	68394	TH 16*
CTX	68396	TH 18*
	68397	TH 20*
	68400	TH 26*
	68392	TH 14*
	68394	TH 16*
	68396	TH 18*
Winkler	68397	TH 20*
	68400	TH 26*
	68401	TH 32
	68402	TH 40
	68403	TH 50 (S)
	68392	TH 14*
	68394	TH 16*
WKS-Press	68395	TH 17*
	68397	TH 20*
	68400	TH 26*
	68401	TH 32
	68402	TH 40
	68312	F 16*
	68314	F 20*
	68315	F 26*
	68316	F 32
	68330	H 16*
	68333	H 20*
	68335	H 26*
XtraConnect	68336	H 32
	68394	TH 16*
	68397	TH 20*
	68400	TH 26*
	68401	TH 32
	68406	U 16*
	68408	U 20*
	68409	(NW 26) U 25*
	68410	U 32
	68392	TH 14*
	68394	TH 16*
Zetaesse	68396	TH 18*
Multistrato	68397	TH 20*
EUROPEX	68400	TH 26*
	68401	TH 32
	68405	U 14*
	68406	U 16*
	68407	U 18*
	68408	U 20*
	68392	TH 14*
	68394	TH 16*
Zetaesse	68396	TH 18*
Multistrato	68397	TH 20*
ISOPEX	68400	TH 26*
	68401	TH 32
	68405	U 14*
	68406	U 16*
	68407	U 18*
	68408	U 20*
	68392	TH 14*
Zetaesse Rame	68394	TH 16*
HydroSAN	68397	TH 20*
	68405	U 14*
	68406	U 16*
	68408	U 20*
	68392	TH 14*
	68394	TH 16*
Zetaesse Rame	68397	TH 20*
ThermoSan	68405	U 14*
	68406	U 16*
	68408	U 20*
	68394	TH 16*
	68395	TH 17*
	68397	TH 20*
ZEWOTHERM	68400	TH 26*
	68401	TH 32
	68402	TH 40
	68403	TH 50 (S)
	68404	TH 63 (S)
	68418	US 3/8**
ZURN	68416	US 1/2**
INDUSTRIES	68417	US 3/4**
ZURN PEX	68415	US 1**
	68420	US 1.1/4**



to the Management Quality



MÁQUINAS ROSCADORAS / PIPE THREADING MACHINES / FILIERES ELECTRIQUES / GEWINDESCHNEIDMASCHINEN / FILETTATRICI ELETTRICA / MÁQUINAS ROSCADORAS / РЕЗЬБОНАРЕЗНЫЕ МАШИНЫ

### ROSCAMATIC - 1.1/2

CAP.	W	V	R.P.M.	Kg.
1/4-1.1/2"	1250	230V (50-60Hz) 110V (50-60Hz)	48	46

Motor Univ. / Moteur Univ. / Motore Univ.

Tubos / Pipes / Tubes: 1/4"-1.1/2"

Varilla / Rod / Boulon: 10mm-36mm



EQUIPO STANDARD / STANDARD EQUIPMENT / EQUIPEMENT STANDARD / STANDARDZUBEHÖR / EQUIPAGGIAMENTO STANDARD / EQUIPAMENTO STANDARD / СТАНДАРТНЫЙ КОМПЛЕКТ

COD	Icon	V	Icon	Icon	Icon	Icon	Icon	Kg.
60140	BSPT	230V (50-60Hz)	81612	1/2-3/4", 1-1.1/2"	•	•	•	46
60141	NPT	(50-60Hz)						
60142	BSPT	110V (50-60Hz)						
60143	NPT	(50-60Hz)						

REPUESTOS / SPARE PARTS / RECHANGES / ERSATZTEILE / ACCESORI / ACESSORIOS / ЗАПАСНЫЕ ЧАСТИ

Icon	Icon	Icon	Icon	Icon	Icon	Icon	Icon	Icon
BSPT-NPT	BSW	METRIC	PG	Icon	Icon	HSS	Icon	5L
81612	81686	81617	81618	81614	81615	64104	64131	64002

BSPT		BSPT (HSS)		NPT		NPT (HSS)	
COD	Icon	COD	Icon	COD	Icon	COD	Icon
64108	1/4-3/8"	64111	1/4-3/8"	64114	1/4-3/8"	64117	1/4-3/8"
64109	1/2-3/4"	64112	1/2-3/4"	64115	1/2-3/4"	64118	1/2-3/4"
64110	1-1.1/2"	64113	1-1.1/2"	64116	1-1.1/2"	64119	1-1.1/2"

METRICO / METRIC (HSS)		BSW (HSS)	
COD	Icon	COD	Icon
64135	10	64120	3/8"
64136	12	64121	1/2"
64137	14-16	64122	5/8"
64138	18-22	64123	3/4"
64139	24-27	64124	7/8"
64141	30-33	64125	1"
64142	36	64126	1.1/8-1.1/4"
		64127	1.1/2"

PG (HSS)	
COD	Icon
64146	PG9-PG16
64147	PG21-PG36



## MÁQUINAS PARA TUBO / PIPING MACHINES / MACHINES POUR TUBE / ROHRBEARBEITUNGSMASCHINEN / MACCHINE PER TUBI / MÁQUINAS PARA TUBO / МАШИНЫ ДЛЯ ОБРАБОТКИ ТРУБ

MÁQUINAS ROSCADORAS / PIPE THREADING MACHINES / FILIERES ELECTRIQUES / GEWINDESCHNEIDMASCHINEN / FILETTATRICE ELETTRICHE / MÁQUINAS ROSCADORAS / РЕЗЬБОНАРЕЗНЫЕ МАШИНЫ

### ROSCAMATIC - 2

CAP.	W	V	R.P.M.	Kg
1/4-2"	750	230V (50-60Hz) 110V (50-60Hz)	22	65

Motor Asíncrono / Condenser Motor / Moteur de Condensateur / Kondensatormotor / Motore Asíncrono / Motor Assíncrono / ИНДУКЦИОННЫЙ МОТОР

Tubos / Pipes / Tubes: 1/4"-2"

Varilla / Rod / Boulon: 10mm-52mm



EQUIPO STANDARD / STANDARD EQUIPMENT / EQUIPEMENT STANDARD / STANDARDZUBEHÖR / EQUIPAGGIAMENTO STANDARD / EQUIPAMENTO STANDARD / СТАНДАРТНЫЙ КОМПЛЕКТ

COD	Icon	V	Icon	Icon	Icon	Icon	Icon	Kg
60150	BSPT	230V	81600	1/2-3/4" 1-2"	●	●	●	65
60151	NPT	(50-60Hz)						
60152	BSPT	110V						
60153	NPT	(50-60Hz)						

REPUESTOS / SPARE PARTS / RECHANGES / ERSATZTEILE / ACCESORI / ACESSORIOS / ЗАПАСНЫЕ ЧАСТИ

Icon	Icon	Icon	Icon	Icon	Icon	Icon	Icon	Icon	Icon	Icon
BSPT-NPT-BSPP	BSW	METRIC	UNC	PG	Icon	Icon	Icon	HSS	Icon	Icon
81600	81619	81620	82918	81621	81601	81602	64104	64131	81603	64002

BSPT		BSPT (HSS)		NPT		NPT (HSS)	
COD	Icon	COD	Icon	COD	Icon	COD	Icon
64148	1/4-3/8"	64151	1/4-3/8"	64154	1/4-3/8"	64157	1/4-3/8"
64149	1/2-3/4"	64152	1/2-3/4"	64155	1/2-3/4"	64158	1/2-3/4"
64150	1-2"	64153	1-2"	64156	1-2"	64159	1-2"

BSPP		BSPP (HSS)		METRICO / METRIC (HSS)	
COD	Icon	COD	Icon	COD	Icon
64495	1/4-3/8"	64498	1/4-3/8"	64180	10
64496	1/2-3/4"	64499	1/2-3/4"	64181	12
64497	1-2"	64500	1-2"	64182	14-16
				64183	18-22
				64184	24-27
				64186	30-33
				64187	36
				64188	42-45
				64189	48-50-52

BSW (HSS)				PG (HSS)		UNC (HSS)			
COD	Icon	COD	Icon	COD	Icon	COD	Icon	COD	Icon
64160	3/8"	64165	1"	64200	PG9-PG16	64770	1/4"	64778	7/8"
64161	1/2"	64166	1.1/8-1.1/4"	64201	PG21-PG36	64771	5/16"	64779	1"
64162	5/8"	64167	1.1/2"	64202	PG42-PG-48	64772	3/8"	64780	1.1/8"
64163	3/4"	64168	1.5/8-1.3/4"			64773	7/16"	64781	1.1/4"
64164	7/8"	64169	1.7/8-2"			64774	1/2"	64782	1.3/8"
						64775	9/16"	64783	1.1/2"
						64776	5/8"	64784	1.3/4"
						64777	3/4"	64785	2"



MÁQUINAS ROSCADORAS / PIPE THREADING MACHINES / FILIERES ELECTRIQUES / GEWINDESCHNEIDMASCHINEN / FILETTATRICE ELETTRICHE / MÁQUINAS ROSCADORAS / РЕЗЬБОНАРЕЗНЫЕ МАШИНЫ

ROSCAMATIC - 3

CAP.	W	V	R.P.M.	Kg.
1/2-3"	750	230V (50-60Hz) 110V (50-60Hz)	(1/2-2") = 25 (2.1/2-3") = 11	125

Motor Asíncrono / Condenser Motor / Moteur de Condensateur / Kondensatormotor / Motore Asíncrono / Motor Assíncrono / ИНДУКЦИОННЫЙ МОТОР

Sistema de copiado de rosca / Notch profiling die head. Copy system / Entaille profilant. Le système principal de copie de matrice / Kerbe, Profiliert Schneidkopf inkl. / Sistema de filettatura a copiare / Sistema de copiador de rosca / УНИВЕРСАЛЬНАЯ РЕЗЬБОНАРЕЗНАЯ ГОЛОВА

Tubos / Pipes / Tubes: 1/2"-3"



EQUIPO STANDARD / STANDARD EQUIPMENT / EQUIPEMENT STANDARD / STANDARDZUBEHÖR / EQUIPAGGIAMENTO STANDARD / EQUIPAMENTO STANDARD / СТАНДАРТНЫЙ КОМПЛЕКТ

COD	Icon	V	2 un	3 un	Icon	Icon	5L	Kg.
60160	BSPT	230V						
60161	NPT	(50-60Hz)	1/2-2"	1/2-3/4" 1-2"	•	•	•	125
60162	BSPT	110V	2.1/2-3"	2.1/2-3"				
60163	NPT	(50-60Hz)						

REPUESTOS / SPARE PARTS / RECHANGES / ERSATZTEILE / ACCESORI / ACESSORIOS / ЗАПАСНЫЕ ЧАСТИ

Icon	Icon	Icon	Icon	Icon	Icon	Icon	Icon
1/2-2	2.1/2-3				HSS		5L
81604	81605	81606	81607	64104	64131	81603	64002

BSPT		BSPT (HSS)		NPT		NPT (HSS)	
COD	Icon	COD	Icon	COD	Icon	COD	Icon
64205	1/2-3/4"	64209	1/2-3/4"	64213	1/2-3/4"	64217	1/2-3/4"
64206	1-2"	64210	1-2"	64214	1-2"	64218	1-2"
64207	2.1/2-3"	64211	2.1/2-3"	64215	2.1/2-3"	64219	2.1/2-3"



## MÁQUINAS PARA TUBO / PIPING MACHINES / MACHINES POUR TUBE / ROHRBEARBEITUNGSMASCHINEN / MACCHINE PER TUBI / MÁQUINAS PARA TUBO / МАШИНЫ ДЛЯ ОБРАБОТКИ ТРУБ

MÁQUINAS ROSCADORAS / PIPE THREADING MACHINES / FILIERES ELECTRIQUES / GEWINDESCHNEIDMASCHINEN / FILETTATRICE ELETTRICHE / MÁQUINAS ROSCADORAS / РЕЗЬБОНАРЕЗНЫЕ МАШИНЫ

### ROSCAMATIC - 3 "COMBI"

CAP.	W	V	R.P.M.	Kg
1/2-3"	750	230V (50-60Hz) 110V (50-60Hz)	(1/2-2") = 25 (2.1/2-3") = 11	100

Motor Asincrono / Condenser Motor / Moteur de Condensateur / Kondensatormotor / Motore Asincrono / Motor Assíncrono / ИНДУКЦИОННЫЙ МОТОР

Sistema de copiado de rosca / Notch profiling die head. Copy system / Entaille profilant. Le système principal de copie de matrice / Kerbe, Profiliert Schneidkopf inkl. / Sistema de filettatura a copiare / Sistema de copiar de rosca / УНИВЕРСАЛЬНАЯ РЕЗЬБОНАРЕЗНАЯ ГОЛОВА

Tubos / Pipes / Tubes: 1/2"-3"



EQUIPO STANDARD / STANDARD EQUIPMENT / EQUIPEMENT STANDARD / STANDARDZUBEHÖR / EQUIPAGGIAMENTO STANDARD / EQUIPAMENTO STANDARD / СТАНДАРТНЫЙ КОМПЛЕКТ

COD	Icon	V	2 un	3 un	Icon	Icon	Kg
60164	BSPT	230V					100
60165	NPT	(50-60Hz)	1/2-2"	1/2-3/4" 1-2"	●	●	
60166	BSPT	110V	2.1/2-3"	2.1/2-3"			
60167	NPT	(50-60Hz)					

REPUESTOS / SPARE PARTS / RECHANGES / ERSATZTEILE / ACCESORI / ACESSORIOS / ЗАПАСНЫЕ ЧАСТИ

Icon	Icon	Icon	Icon	Icon	HSS	Icon	5L
81604	81605	81606	81607	64104	64131	81603	64002

BSPT		BSPT (HSS)		NPT		NPT (HSS)	
COD	Icon	COD	Icon	COD	Icon	COD	Icon
64205	1/2-3/4"	64209	1/2-3/4"	64213	1/2-3/4"	64217	1/2-3/4"
64206	1-2"	64210	1-2"	64214	1-2"	64218	1-2"
64207	2.1/2-3"	64211	2.1/2-3"	64215	2.1/2-3"	64219	2.1/2-3"

RANURADORA HIDRÁULICA / HYDRAULIC ROLL GROOVER / RAINUREUSE HYDRAULIQUE / HYDRAULISCHE ROLLNUTMASCHINE / SCANALATORE IDRAULICO / RANURADORA HIDRAULICA / ГИДРАВЛИЧЕСКИЙ ЖЕЛОБОНАКАТЧИК

COD	CAP	Kg	Icon
60185	1.1/4-12"	23	1

Opcional / optional / optionnel



ACEITERA / OILER / RECIPIENT À HUILE DE COUPE / ÖLKANISTER / OLIATORI / ALMOTOLIA / МАСЛЯНЫЙ НАСОС

COD	CAP	Kg	Icon
64130	5L	3,0	1



\*G12: GARANTIA 12 MESES / 12 MONTHS OF WARRANTY / 12 MOIS DE GARANTIE / 12 MONATEN GARANTIE / 12 MAANDEN GARANTIE / 12 MESI DI GARANZIA / 12 МЕСЯЦЕВ ГАРАНТИЯ

### MÁQUINAS ROSCADORAS / PIPE THREADING MACHINES / FILIERES ELECTRIQUES / GEWINDESCHNEIDMASCHINEN / FILETTATRICE ELETTRICHE / MÁQUINAS ROSCADORAS / РЕЗЬБОНАРЕЗНЫЕ МАШИНЫ

#### ROSCAMATIC - 4

CAP.	W	V	R.P.M.	Kg
1/2-4"	750	230V (50-60Hz)	(1/2-2") = 25	150
		110V (50-60Hz)	(2.1/2-4") = 11	

Motor Asíncrono / Condenser Motor / Moteur de Condensateur / Kondensatormotor / Motore Asincrono / Motor Assincrono / ИНДУКЦИОННЫЙ МОТОР

Sistema de copiado de rosca / Notch profiling die head. Copy system / Entaille profilant. Le système principal de copie de matrice / Kerbe, Profiliert Schneidkopf inkl. / Sistema de filettatura a copiare / Sistema de copiador de rosca / УНИВЕРСАЛЬНАЯ РЕЗЬБОНАРЕЗНАЯ ГОЛОВА

Tubos / Pipes / Tubes: 1/2"-4"

Varilla / Rod / Boulon: 10mm-52mm



#### EQUIPO STANDARD / STANDARD EQUIPMENT / EQUIPEMENT STANDARD / STANDARDZUBEHÖR / EQUIPAGGIAMENTO STANDARD / EQUIPAMENTO STANDARD / СТАНДАРТНЫЙ КОМПЛЕКТ

COD	Icon	V	2 un	3 un	Icon	Icon	5L	Kg
60170	BSPT	230V	1/2-2"	1/2-3/4"	•	•	•	150
60171	NPT	(50-60Hz)						
60172	BSPT	110V	2.1/2-4"	1-2"	•	•		
60173	NPT	(50-60Hz)						

#### REPUESTOS / SPARE PARTS / RECHANGES / ERSATZTEILE / ACCESSORI / ACESSORIOS / ЗАПАСНЫЕ ЧАСТИ

Icon	Icon	Icon	Icon	Icon	Icon	Icon	Icon	Icon	Icon	Icon	Icon	Icon	Icon	Icon
1/2-2	2.1/2-4	BSPP	BSW	METRIC	UNC	PG	Icon	Icon	Icon	Icon	HSS	5L	81608	81609
81608	81609	81687	81721	81616	82919	81795	81610	81611	64104	64131	81603	64002		

BSPT		BSPT (HSS)		NPT		NPT (HSS)	
COD	Icon	COD	Icon	COD	Icon	COD	Icon
64205	1/2-3/4"	64209	1/2-3/4"	64213	1/2-3/4"	64217	1/2-3/4"
64206	1-2"	64210	1-2"	64214	1-2"	64218	1-2"
64208	2.1/2-4"	64212	2.1/2-4"	64216	2.1/2-4"	64220	2.1/2-4"

BSPP		BSPP (HSS)		METRICO / METRIC (HSS)	
COD	Icon	COD	Icon	COD	Icon
64495	1/4-3/8"	64498	1/4-3/8"	64180	10
64496	1/2-3/4"	64499	1/2-3/4"	64181	12
64497	1-2"	64500	1-2"	64182	14-16
				64183	18-22
				64184	24-27
				64186	30-33
				64187	36
				64188	42-45
				64189	48-50-52

BSW (HSS)		PG (HSS)		UNC (HSS)	
COD	Icon	COD	Icon	COD	Icon
64160	3/8"	64165	1"	64770	1/4"
64161	1/2"	64166	1.1/8-1.1/4"	64771	5/16"
64162	5/8"	64167	1.1/2"	64772	3/8"
64163	3/4"	64168	1.5/8-1.3/4"	64773	7/16"
64164	7/8"	64169	1.7/8-2"	64774	1/2"
				64775	9/16"
				64776	5/8"
				64777	3/4"
				64778	7/8"
				64779	1"
				64780	1.1/8"
				64781	1.1/4"
				64782	1.3/8"
				64783	1.1/2"
				64784	1.3/4"
				64785	2"

## MÁQUINAS PARA TUBO / PIPING MACHINES / MACHINES POUR TUBE / ROHRBEARBEITUNGSMASCHINEN / MACCHINE PER TUBI / MÁQUINAS PARA TUBO / МАШИНЫ ДЛЯ ОБРАБОТКИ ТРУБ

MÁQUINAS ROSCADORAS / PIPE THREADING MACHINES / FILIERES ELECTRIQUES / GEWINDESCHNEIDMASCHINEN / FILETTATRICE ELETTRICHE / MÁQUINAS ROSCADORAS / РЕЗЬБОНАРЕЗНЫЕ МАШИНЫ

### ROSCAMATIC - 6

CAP.	W	V	R.P.M.	Kg.
2.1/2-6"	1100	230V (50-60Hz) 110V (50-60Hz)	(2.1/2-4") = 16 (5-6") = 6	210

Motor Asíncrono / Condenser Motor / Moteur de Condensateur / Kondensatormotor / Motore Asincrono / Motor Assincrono / ИНДУКЦИОННЫЙ МОТОР

Sistema de copiado de rosca / Notch profiling die head. Copy system / Entaille profilant. Le système principal de copie de matrice / Kerbe, Profiliert Schneidkopf inkl. / Sistema de filettatura a copiare / Sistema de copiador de rosca / УНИВЕРСАЛЬНАЯ РЕЗЬБОНАРЕЗНАЯ ГОЛОВА

Tubos / Pipes / Tubes: 2.1/2"-6"



EQUIPO STANDARD / STANDARD EQUIPMENT / EQUIPEMENT STANDARD / STANDARDZUBEHÖR / EQUIPAGGIAMENTO STANDARD / EQUIPAMENTO STANDARD / СТАНДАРТНЫЙ КОМПЛЕКТ

COD	Icon	V	Icon	Icon	Icon	Icon	Icon	Kg.
60190	BSPT	230V	2 un	2 un				210
60191	NPT	(50-60Hz)	2.1/2-4"	2.1/2-4"				
60192	BSPT	110V	5-6"	5-6"				
60193	NPT	(50-60Hz)						

REPUESTOS / SPARE PARTS / RECHANGES / ERSATZTEILE / ACCESORI / ACESSORIOS / ЗАПАСНЫЕ ЧАСТИ

Icon	Icon	Icon	Icon	Icon	Icon	Icon	Icon
2.1/2-4	5-6				HSS		5L
81622	81623	81624	81625	64271	64132	81603	64002

BSPT		BSPT (HSS)		NPT		NPT (HSS)	
COD	Icon	COD	Icon	COD	Icon	COD	Icon
64208	2.1/2-4"	64212	2.1/2-4"	64216	2.1/2-4"	64220	2.1/2-4"
64221	5-6"	64223	5-6"	64222	5-6"	64224	5-6"

# EGA Master S.A.

## ART IN INNOVATION

**ACCESORIOS / SPARE PARTS / RECHANGES / ZUBEHÖR / ACCESSORI / ACESSORIOS /  
ЗАПАСНЫЕ ЧАСТИ**
**CARRO HIDRÁULICO / HYDRAULIC TROLLEY / CHARIOT HYDRAULIQUE / HYDRAULISCHER ARBEITSWAGEN /  
CARRELLO IDRAULICO / CARRO HIDRAULICO / ГИДРАВЛИЧЕСКАЯ ТЕЛЕЖКА**

COD	A-B	L min - max	CAP	Kg.	
60184	600-900	295-1020	500kg	125	1

**CARRO MANUAL / HAND TROLLEY / CHARIOT MANUEL / HANDGESTELLTER ARBEITSWAGEN / CARRELLO  
MANUALE / CARRO MANUAL / РУЧНАЯ ТЕЛЕЖКА**

COD		Kg.	
60181	ROSCAMATIC-2	30	1
60180	ROSCAMATIC-3	28	
60182	ROSCAMATIC-4	28	
60183	ROSCAMATIC-6	30	

 No válida para modelos "COMBI" / Not valid for "COMBI" models  
 Non valide pour les modèles "COMBI"

**SOPORTE PARA TUBOS / PIPE BRACKET / SUPPORT PER TUBES / ROHRHALTEWINKEL / SUPPORTO PER TUBI /  
SUPPORTO PARA TUBOS / ПОДСТАВКА ДЛЯ ТРУБ**

COD	L min - max	Kg.	
60179	750-1200	5,0	1

**JUEGO DE NIPLEROS / NIPPLE CHUCK KIT / KIT DE PORTE-NIPPLE / NIPPEL-SPANN-FUTTER-SATZ / MANDRINO  
PER NIPPLI / JOGO DE PORTA-CASQUILHO / ПАТРОН ДЛЯ БОЧАТ**

COD		CAP	ROSCAMATIC	Kg.	
60178	NPT	1/2"-3/4"-1"- 1.1/4"-1.1/2"-2"	2-3-4	5	1

**NEW**
**ACEITERA / OILER / RECIPIENT À HUILE DE COUPE / ÖLKANISTER / OLIATORI / ALMOTOLIA / МАСЛЯНЫЙ  
НАСОС**

COD	CAP	Kg.	
64130	5L	4,0	1

**ACEITE DE CORTE / CUTTING OIL / HUILE DE COUPE / GEWINDESCHNEIDÖL / OLIO DATAGLIO / OLEO DE CORTE /  
РЕЗЬБОНАРЕЗНОЕ МАСЛО**

COD	CAP	Kg.	
64006	2L	2,0	1
64002	5L	4,5	



## MÁQUINAS PARA TUBO / PIPING MACHINES / MACHINES POUR TUBE / ROHRBEARBEITUNGSMASCHINEN / MACCHINE PER TUBI / MÁQUINAS PARA TUBO / МАШИНЫ ДЛЯ ОБРАБОТКИ ТРУБ

MÁQUINAS ROSCADORAS / PIPE THREADING MACHINES / FILIERES ELECTRIQUES / GEWINDESCHNEIDMASCHINEN / FILETTATRICI ELETTRICA / MÁQUINAS ROSCADORAS / РЕЗЬБОНАРЕЗНЫЕ МАШИНЫ

MASTERMATIC - 1

CAP.	W	V	Kg.
1.1/4"	1150	230V (50-60Hz)	6,0
		110V (50-60Hz)	



**CABEZAS DE TERRAJA:** Especialmente diseñadas con una mayor longitud para un asentamiento más preciso de los peines proporcionando una mejor rosca y más suavidad en el trabajo.

**THREADING HEADS:** Specially designed and enlarged heads providing more precise dies setting for smoother and better threading.

**FILIERES:** Les filières sont spécialement conçues pour fixer plus précisément les peignes. Il en résulte une plus grande qualité de filetage.

**SCHNEIDKÖPFE:** Spezial entwickelte Schneidköpfe für eine genauere Einstellung der Schneidbacken sowie ein besseres Gewinde.

**TESTE:** Fatti con una guida allungata per facilitare l'infilamento del tubo e la estrazione dalla testa. Coperchio di precisione meccanizzato per un'ottima guida dei pettini e sopra-dimensionato per un'assorbimento corretto della forza di lavoro.

**CABEÇAS DE TARRACHA:** Especialmente desenhadas com uma maior longitude para um assentamento mais preciso dos caçonetes, proporcionando uma melhor rosca e mais suavidade no trabalho.

**РЕЗЬБОНАРЕЗНЫЕ ГОЛОВКИ:** СПЕЦИАЛЬНО РАЗРАБОТАНЫ ДЛЯ ВЫПОЛНЕНИЯ БОЛЕЕ МЯГКОЙ НАРЕЗКИ



						230V		110V		Kg.
1/4"	3/8"	1/2"	3/4"	1"	1.1/4"	COD BSPT	COD NPT	COD BSPT	COD NPT	
-	-	●	●	●	●	69082	69087	69092	69097	13
-	●	●	●	●	●	69083	69088	69093	69098	14
●	●	●	●	●	●	69084	69089	69094	69099	15



230V

60130

110V

60131



50000



81530



64001

ACEITERA / OILER / RECIPIENT À HUILE DE COUPE / ÖLKANISTER / OLIIATORI / ALMOTOLIA / МАСЛЯНЫЙ НАСОС

COD	CAP	Kg.	
64130	5L	4,0	1



\*G12: GARANTIA 12 MESES / 12 MONTHS OF WARRANTY / 12 MOIS DE GARANTIE / 12 MONATEN GARANTIE / 12 MAANDEN GARANTIE / 12 MESI DI GARANZIA / 12 МЕСЯЦЕВ ГАРАНТИЯ

MÁQUINAS ROSCADORAS / PIPE THREADING MACHINES / FILIERES ELECTRIQUES / GEWINDESCHNEIDMASCHINEN / FILETTATRICI ELETTRICA / MÁQUINAS ROSCADORAS / РЕЗЬБОНАРЕЗНЫЕ МАШИНЫ

### MASTERMATIC - 2

CAP.	W	V	Kg.
2"	1350	230V (50-60Hz)	8,0
		110V (50-60Hz)	

**CABEZAS DE TERRAJA:** Especialmente diseñadas con una mayor longitud para un asentamiento más preciso de los peines proporcionando una mejor rosca y más suavidad en el trabajo.

**THREADING HEADS:** Specialty designed and enlarged heads providing more precise dies setting for smoother and better threading.

**FILIERES:** Les filières sont spécialement conçue pour fixer plus précisément les peignes. Il en résulte une plus grande qualité de filetage.

**SCHNEIDKÖPFE:** Spezial entwickelte Schneidköpfe für eine genauere Einstellung der Schneidbacken sowie ein besseres Gewinde.

**TESTE:** Fatti con una guida allungata per facilitare l'infilamento del tubo e la estrazione dalla testa. Coperchio di precisione meccanizzato per un'ottima guida nei pettini e sopra-dimensionatto per un 'assorbimento corretto della forza di lavoro.

**CABEÇAS DE TARRACHA:** Especialmente desenhadas com uma maior longitude para um assentamento mais preciso dos caçonetes, proporcionando uma melhor rosca e mais suavidade no trabalho.

**РЕЗЬБОНАРЕЗНЫЕ ГОЛОВКИ:** СПЕЦИАЛЬНО РАЗРАБОТАНЫ ДЛЯ ВЫПОЛНЕНИЯ БОЛЕЕ МЯГКОЙ НАРЕЗКИ



								230V		110V		Kg.
1/4"	3/8"	1/2"	3/4"	1"	1.1/4"	1.1/2"	2"	COD BSPT	COD NPT	COD BSPT	COD NPT	
-	-	●	●	●	●	●	●	69114	69121	69174	69181	13
-	●	●	●	●	●	●	●	69115	69122	69175	69182	14
●	●	●	●	●	●	●	●	69116	69123	69176	69183	15

<b>230V</b>	<b>110V</b>					
60148	60149	51050	85930	85931	64001	

ACEITERA / OILER / RECIPIENT À HUILE DE COUPE / ÖLKANISTER / OLIIATORI / ALMOTOLIA / МАСЛЯНЫЙ НАСОС

COD	CAP	Kg.	
64130	5L	4,0	1



## MÁQUINAS PARA TUBO / PIPING MACHINES / MACHINES POUR TUBE / ROHRBEARBEITUNGSMASCHINEN / MACCHINE PER TUBI / MÁQUINAS PARA TUBO / МАШИНЫ ДЛЯ ОБРАБОТКИ ТРУБ

RANURADORA HIDRÁULICA / HYDRAULIC ROLL GROOVER / RAINUREUSE HYDRAULIQUE / HYDRAULISCHE ROLLNUTMASCHINE / SCANALATORE IDRAULICO / RANHURADORA HIDRÁULICA / ГИДРАВЛИЧЕСКИЙ ЖЕЛОБОНАКАТЧИК

### RANUMATIC "COMBI"

CAP.	W	V	R.P.M.	Kg.
1.1/4"-12"	750	230V (50-60Hz) 110V (50-60Hz)	(1.1/4-6") = 25 (8-12") = 11	110

Motor Asíncrono / Condenser Motor / Moteur de Condensateur / Kondensatormotor / Motore Asincrono / Motor Assíncrono / ИНДУКЦИОННЫЙ МОТОР



Tubos / Pipes / Tubes: 1.1/4"-12"

CAPACIDAD DE RANURADO DE TUBOS / PIPE GROOVING CAPACITY / DIAMÉTRE MAXIMUM DE RAINURAGE / KAPAZITÁT DER RÖHRNUTEN / CAPACITA DI SCANALATURA DEL TUBO / CAPACIDADE DE RANHURAGEM DE TUBO / ПАРАМЕТРЫ ЖЕЛОБОНАКАТКИ

	1.1/4"	1.1/2"	2"	2.1/2"	3"	4"	6"	8"	10"	12"
SCHEDULE 10	2,8	2,8	2,8	3,0	3,0	3,4	3,4	3,8	4,2	4,6
SCHEDULE 40	3,6	3,4	3,9	5,2	5,5	6,0	7,1	8,2	-	-
DIN 2440	3,25	3,25	3,65	3,65	4,03	4,5	4,85	-	-	-

INOX - hasta 4,8 mm  
up to 4,8 mm

EQUIPO STANDARD / STANDARD EQUIPMENT / EQUIPEMENT STANDARD / STANDARDZUBEHÖR / EQUIPAGGIAMENTO STANDARD / EQUIPAMENTO STANDARD / СТАНДАРТНЫЙ КОМПЛЕКТ

COD	V				Kg.
60168	230V (50-60Hz)	1.1/4-6"	•	•	110
60169	110V (50-60Hz)	8-12"	•	•	110

REPUESTOS / SPARE PARTS / RECHANGES / ERSATZTEILE / ACCESSORI / ACESSORIOS / ЗАПАСНЫЕ ЧАСТИ

COD			
60174	1.1/4"-6"	8"-12"	81603
60175	60176	81603	60176

CARRO DE ROSCAR 3" / THREADING CARRIAGE / CHARIOT DE FILETAGE 3" / GEWINDESCHNEIDHALTER / BANCO MOTORIZZATI / CARRO DE ROSCAR 3" / РЕЗЬБОНАРЕЗНАЯ КАРЕТКА

COD			2 un		3 un			Kg.
60186	BSPT	1/2-2"	1/2-3/4"	•	•	•	•	23
60189	NPT	2.1/2-3"	1-1/2", 2.1/2-3"	•	•	•	•	23

Opcional / optional / optionnel



CABALLETE / PIPE SUPPORT / SUPPORT DE TUBE / ROHRHALTEWINKEL / CAVALLETTO PER TUBI / CAVALETE PARA TUBO / ПОДСТАВКА ДЛЯ ТРУБ

COD	Kg.
60176	7,5





\*G12: GARANTIA 12 MESES / 12 MONTHS OF WARRANTY / 12 MOIS DE GARANTIE / 12 MONATEN GARANTIE / 12 MAANDEN GARANTIE / 12 MESI DI GARANZIA / 12 МЕСЯЦЕВ ГАРАНТИЯ



SIERRA DE CINTA / ELECTRIC BANDSAW / SCIE À RUBAN / BANDSÄGE / SEGA DI NASTRO / SERRA DE FITA / ЛЕНТОЧНАЯ ПИЛА

MULTIFUNCIÓN / MULTIFUNCTION / MULTI-FONCTIONS / MULTIFUNKTION / MULTIFUNZIONE / MULTIFUNÇÕES / МНОГОФУНКЦИОНАЛЬНАЯ

COD	CAP	CAP	W	V		Kg.
60128	●	■	320	230V (50-60Hz)	1356x13x0,65	21
60129	●	■	320	110V (50-60Hz)	1356x13x0,65	21

COD	
64311	1356x13x0,65 - 14
64312	1356x13x0,65 - 18

CABEZAL PORTÁTIL / PORTABLE HEAD / TÊTE PORTABLE / TRAGBARER KOPF / TESTA PORTATILE / CABEÇA PORTATIL / РУЧНАЯ ЛЕНТОЧНАЯ ПИЛА

COD	CAP	CAP	W	V		Kg.
60220	●	■	320	230V (50-60Hz)	1356x13x0,65	10
60221	●	■	320	110V (50-60Hz)	1356x13x0,65	10

COD	
64311	1356x13x0,65 - 14
64312	1356x13x0,65 - 18

SIERRA ELECTROPORTÁTIL / RECIPROCATING SAW / SCIE SABRE UNIVERSELLE / TRAGBARE ELEKTROSÄGE / SEGHETO ELETRICO / SERRA ELECTRO PORTATIL / САБЕЛЬНАЯ ПИЛА

COD	CAP	W	R.P.M.	V	Kg.
60216	metal / wood	750	2500	230V (50-60Hz)	5,0
60217	metal / wood	750	2500	110V (50-60Hz)	5,0

COD	
64411 (metal)	152x0,9 - 25,5
64412 (wood)	152x1,2 - 10,5



CE\*G12

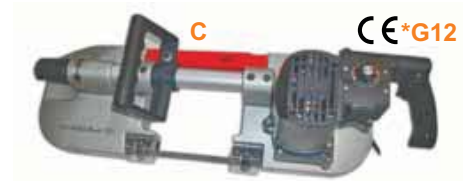

## MÁQUINAS PARA TUBO / PIPING MACHINES / MACHINES POUR TUBE / ROHRBEARBEITUNGSMASCHINEN / MACCHINE PER TUBI / MÁQUINAS PARA TUBO / МАШИНЫ ДЛЯ ОБРАБОТКИ ТРУБ

CORTATUBOS PROPULSADO / POWER PIPE CUTTER / COUPE TUBE ELECTRIQUE / ROHRTRENNGERÄT / TAGLIATUBI ALIMENTATO / CORTA TUBOS ELECTRO-HIDRÁULICO / ТРУБОРЕЗ С ЭЛЕКТРОПРИВОДОМ

### KIT CORTAMATIC - 12

SET CON MASTERMATIC-2 / SET INCLUDING MASTERMATIC-2 / SET COMPLET AVEC MASTERMATIC-2 / SET INCLUSIVE MASTERMATIC-2 / ASSORTIMENTO CON MASTERMATIC 2 / CONJUNTO COM MASTERMATIC 2 / НАБОР С MASTERMATIC-2

COD	V	CAP	Kg.
60000	230V (50-60Hz)	2.1/2-12"	75
60001	110V (50-60Hz)		



### CORTAMATIC - 12

COD	CAP	Kg.
60002	2.1/2-12"	65



### Especificaciones técnicas / Technical specification / Détails techniques

Poderoso cilindro hidráulico de 10 toneladas / Powerful 10-ton hydraulic cylinder / Cylindre hydraulique puissant de 10 tonnes

Cortes perfectos en escuadra, sin chispas ni polvo / Perfect square cuts, without dust or sparks / Coupes parfaites à angles droits, sans étincelles ni poussière

Incluidos 2 soportes para tubo / 2 pipe stands included / 2 supports pour tube inclus



CAPACIDAD DE CORTE DE TUBOS (ESPEJOR MM) / PIPE CUTTING CAPACITY (THICKNESS MM) / CAPACITÉ DE COUPE-TUBE (ÉPAISSEUR EN MM) / SCHNITTKAPAZITÄT FÜR ROHRE (DICHT E IN MM) / CAPACITÀ DI TAGLIO DEL TUBO (SPESSORE MM) / CAPACIDAD DE CORTE DE TUBOS (ESPESSURA EM MM) / РАЗМЕР ТРУБЫ (ТОЛЩИНА В ММ)

	2.1/2"	3"	4"	5"	6"	8"	10"	12"
SCHEDULE 10	3,05	3,05	3	3,4	3,4	4,78	4,19	4,57
SCHEDULE 40	5,16	5,49	6,02	6,55	7,11	8,18	-	-
DIN 2440	3,65	4,05	4,5	4,85	4,85	-	-	-

REPUESTOS / SPARE PARTS / RECHANGES / ERSATZTEILE / ACCESORI / ACESSORIOS / ЗАПАСНЫЕ ЧАСТИ

60003	60017	60018

\*G12: GARANTIA 12 MESES / 12 MONTHS OF WARRANTY / 12 MOIS DE GARANTIE / 12 MONATEN GARANTIE / 12 MAANDEN GARANTIE / 12 MESI DI GARANZIA / 12 МЕСЯЦЕВ ГАРАНТИЯ

CONGELADOR DE TUBO / PIPE FREEZER / CONGÉLATEUR DE TUBE / ROHR-EINFRIERGERÄT / CONGELATUBI / CONGELADOR DA TUBULAÇÃO / ЗАМОРОЗКА  
MASTERFREEZE

Ø	t.	Ø	t.
1/8"	(Fe) 1min	1"	(Fe) 7min
10-12mm	(Cu)	35mm	(Cu) 10min
1/4"	(Fe) 2min	1.1/4"	(Fe) 11min
14-15mm	(Cu)	42mm	(Cu) 14min
3/8"	(Fe) 3min	1.1/2"	(Fe) 16min
16-18mm	(Cu)	54mm	(Cu) 24min
1/2"	(Fe) 5min	2"	(Fe) 29min
22mm	(Cu)		
3/4"	(Fe) 7min		
28mm	(Cu)		



EQUIPO STANDARD / STANDARD EQUIPMENT / EQUIPEMENT STANDARD / STANDARDZUBEHÖR / EQUIPAGGIAMENTO STANDARD / EQUIPAMENTO STANDARD / СТАНДАРТНЫЙ КОМПЛЕКТ

COD	CAP (Cu)	CAP (Fe)	Kg.
60275	EUR. 10-60mm	1/8"-2"	5,0
60276	USA 1/4"-2"		1

REPUESTOS / SPARE PARTS / RECHANGES / ERSATZTEILE / ACCESSORI / ACESSORIOS / ЗАПАСНЫЕ ЧАСТИ

COD EUR.	(Cu)	(Fe)	COD USA	(Cu)	(Fe)
64460	10-12mm	1/8"	64470	1/4"	1/8"
64461	14-15mm	1/4"	64471	3/8"	1/4"
64462	16-18mm	3/8"	64472	1/2"	3/8"
64463	22mm	1/2"	64473	3/4"	1/2"
64464	28mm	3/4"	64474	1"	3/4"
64465	35mm	1"	64475	1.1/4"	1"
64466	42mm	1.1/4"	64476	1.1/2"	1.1/4"
64467	-	1.1/2"	64477	-	1.1/2"
64468	54mm	-	64478	2"	-
64469	60mm	2	64479	-	2



CONEXIÓN ALARGADERA / EXTENSION ADAPTOR / ADAPTATEUR DE PROLONGATEUR / VERLÄNGERUNGSVERBINDUNG / ADATTATORE PER ESTENSIONE / CONEÇÃO PARA EXTENSÃO / УДЛИНЯЮЩАЯ НАСАДКА

COD	gr.	
64480	30	1



ALARGADERA / EXTENSION / RALLONGE / VERLÄNGERUNG / PROLUNGA / EXTENSÃO / УДЛИНИТЕЛЬ

COD	gr.	
64481	30	1



## MÁQUINAS PARA TUBO / PIPING MACHINES / MACHINES POUR TUBE / ROHRBEARBEITUNGSMASCHINEN / MACCHINE PER TUBI / MÁQUINAS PARA TUBO / МАШИНЫ ДЛЯ ОБРАБОТКИ ТРУБ

CONGELADOR ELÉCTRICO PARA TUBO / ELECTRIC PIPE FREEZER / CONGÉLATEUR ELECTRIQUE À TUBES / ROHR-EINFRIERGERÄT, ELEKTREISCH / CONGELATUBI ELETTRICO / CONGELADOR ELÉTRICO DA TUBULAÇÃO / ЭЛЕКТРОЗАМОРОЗКА

FREEZEMATIC

Ø		t.	Ø		t.
1/8"	(Fe)	3min	3/4"	(Fe)	14,5min
10-12mm	(Cu)	3,5min	28mm	(Cu)	17min
1/4"	(Fe)	4min	1"	(Fe)	18min
14-15mm	(Cu)	5,5min		(Cu)	20min
3/8"	(Fe)	6min	1.1/4"	(Fe)	31min
16-18mm	(Cu)	7min		(Cu)	33min
1/2"	(Fe)	9min			
22mm	(Cu)	11min			



CE\*G12

EQUIPO STANDARD / STANDARD EQUIPMENT / EQUIPEMENT STANDARD / STANDARDZUBEHÖR / EQUIPAGGIAMENTO STANDARD / EQUIPAMENTO STANDARD / СТАНДАРТНЫЙ КОМПЛЕКТ

COD	V	CAP (Cu)	CAP (Fe)	Kg.	
60277	230V (50-60Hz)	10-42mm	1/8"-1.1/4"	23	1
60278	110V (50-60Hz)				



\*G12: GARANTIA 12 MESES / 12 MONTHS OF WARRANTY / 12 MOIS DE GARANTIE / 12 MONATEN GARANTIE / 12 MAANDEN GARANTIE / 12 MESI DI GARANZIA / 12 МЕСЯЦЕВ ГАРАНТИЯ



**HERRAMIENTA PARA COBRE / TOOLS FOR COPPER / OUTILLAGE POUR LE CUIVRE /  
WERKZEUGE FÜR KUPFER / UTENSILI PER RAME / FERRAMENTAS PARA COBRE /  
ИНСТРУМЕНТ ДЛЯ МЕДИ**

## CORTATUBOS UNIQUE UNIQUE TUBE CUTTER COUPE-TUBES UNIQUE



**Medalla de Oro**, Salón Internacional de la Invención, París 2004  
**Gold Medal**, International Inventors Competition, Paris 2004  
**Medaille d'Or**, Salon International de L'Invention, Paris 2004

**1.** Acción rápida y suave gracias a su mecanizado de precisión.  
*Precision machining provides the quickest and smoothest action.*  
*Action rapide et douce, grâce à son usinage très précis.*

**2.** Extremadamente robusto, compacto y fácil de usar.  
*Extremely robust, compact and easy to use.*  
*Très robuste, compact et aisé à utiliser.*

**3.** Escala graduada marcada en láser para facilitar el posicionamiento.  
*Laser marked graduated scale to facilitate working action.*  
*Echelle graduée, marquée au laser, pour faciliter le positionnement.*

**4.** Cuchilla de repuesto incluida en el pomo.  
*Extra cutting wheel at the knob.*  
*Molette de rechange, incluse dans le manche.*

**5.** Puede cortar tubos de cobre, acero inoxidable y plástico con las cuchillas correspondientes.  
*Able to cut copper, inox and plastic pipes with the proper cutting wheels.*  
*Il peut couper du cuivre, de l'inox et du plastique avec les molettes correspondantes.*

**6.** Escariador extraíble puede trabajar montado en el cortatubos o de forma independiente.  
*Extractable reamer can work assembled in the tubing cutter or independently.*  
*L'alésoir extractif peut travailler assemblé au coupe-tubes ou de manière indépendante.*

**7.** Patentado  
*Patented*  
*Breveté*



### CORTATUBOS / TUBE CUTTER / COUPE-TUBES / KUPFER ROHRABSCHNEIDER / TAGLIATUBI / CORTA TUBOS / ТРУБОРЕЗ

#### SERIE CU = COBRE - COPPER - CUIVRE

##### MINI

COD	MAT.	O.D.	gr.				
63176	CU	3-16	90	20	1	63088	20
63106		3-22	120			63110	



##### MINI 30

COD	MAT.	O.D.	gr.				
63168	CU	3-30	210	10	1	63086	20



##### CLASSIC 32

COD	MAT.	O.D.	gr.				
63170	CU	3-32	300	1	1	63110	20



##### TELESCOPIC 32

COD	MAT.	O.D.	gr.				
63105	CU	6-32	290	1	1	63110	20



##### UNIQUE

COD	MAT.	O.D.	gr.				
63077	CU	6-35	480	1	1	63111	10
63119		6-42	550	8			
63187		6-45	600	1			



##### AUTOMATIC 50

COD	MAT.	O.D.	gr.				
63363	CU	6-50	450	1	1	63720	10



##### AUTOMATIC 67

COD	MAT.	O.D.	gr.				
63107	CU	6-67	750	1	1	63111	10



##### AUTOMATIC 127

COD	MAT.	O.D.	gr.				
63174	CU	50-127	1950	1	1	64106	10



##### KIT 3

COD	
69465	63106 - 63170 - 63119



### ROLLCUT

COD	MAT.	O.D.	gr.				
63210	CU	12	230	6	1	63243	10
63211		15	220			63244	
63212		18	250			63245	
63213		22	240			63246	



### EXPOSITORES / DISPLAYS / PRESENTOIRS / DISPLAY / ESPOSITORE / DISPLAY STAND / СТЕНДЫ

SERIE CU = COBRE - COPPER - CUIVRE

20 PCS.

COD	UN.	O.D.
55567	4	63170
		63105
		63077
		63119
		63187



### SERIE INOX / STAINLESS STEEL / INOX / EDELSTAHL / ACCIAIO INOX / AÇO INOXIDAVEL / НЕРЖАВЕЮЩАЯ СТАЛЬ

20 PCS.

COD	UN.	O.D.
55568	4	63094
		63118
		63078
		63121
		63188





CORTATUBOS / TUBE CUTTER / COUPE-TUBES / KUPFER ROHRABSCHNEIDER / TAGLIATUBI / CORTA TUBOS / ТРУБОРЕЗ

SERIE INOX / STAINLESS STEEL / INOX / EDELSTAHL / ACCIAIO INOX / AÇO INOXIDAVEL / НЕРЖАВЕЮЩАЯ СТАЛЬ

### MINI

COD	MAT.	O.D.	gr.				
63190	INOX	3-16	90	20	1	63089	20
63096		3-22	120				



### MINI 30

COD	MAT.	O.D.	gr.				
63169	INOX	3-30	210	10	1	63087	20



### CLASSIC 32

COD	MAT.	O.D.	gr.				
63094	INOX	3-32	300	1	1	63113	20



### TELESCOPIC 32

COD	MAT.	O.D.	gr.				
63118	INOX	6-32	290	1	1	63113	20



### UNIQUE

COD	MAT.	O.D.	gr.				
63078	INOX	6-35	480	1	1	63114	10
63121		6-42	550	8			
63188		6-45	600	1			



### AUTOMATIC 50

COD	MAT.	O.D.	gr.				
63364	INOX	6-50	450	1	1	63721	10



### AUTOMATIC 67

COD	MAT.	O.D.	gr.				
63126	INOX	6-67	750	1	1	63114	10







### KIT 3





COD	
69548	63096 - 63094 - 63121







**ESCARIADORES / REAMERS / ALESOIR / ENTGRATER / SBAVATORI / ESCARIADOR /  
 ЗЕНКОВКА**

COD						
63371	Cu / ACERO / PLÁSTICO / INOX Cu / STEEL / PLASTIC / INOX	90	20	1	64008	64447
63375	LATÓN / FUNDICIÓN BRASS / CAST IRON				64446	64448







COD						
63370	Cu / ACERO / PLÁSTICO / INOX Cu / STEEL / PLASTIC / INOX	50	20	1	64008	-
63374	LATÓN / FUNDICIÓN BRASS / CAST IRON				64446	-







COD						
63369	Cu / ACERO / PLÁSTICO / INOX Cu / STEEL / PLASTIC / INOX	25	20	1	64008	-
63373	LATÓN / FUNDICIÓN BRASS / CAST IRON				64446	-



COD						
63368	Cu / ACERO / PLÁSTICO / INOX Cu / STEEL / PLASTIC / INOX	10	20	1	64008	-
63372	LATÓN / FUNDICIÓN BRASS / CAST IRON				64446	-







COD						
63958	Cu / ACERO / PLÁSTICO / INOX / LATÓN / ALUMINIO	8-35mm / 5/16"-1.3/8"	250	1	1	
63959	Cu / STEEL / PLASTIC / INOX / BRASS / ALUMINIUM	10-54mm / 1/2"-2.1/8"	500			







COD						
63085	Cu / LATÓN / ALUMINIO Cu / BRASS / ALUMINIUM	40	235	10	1	

**ESCARIADOR DE CHAFLANES / CHAMFERBIT / EBAVUREUR Á CHANFREINS / ABSCHRÄGER / SBAVATORE PER  
 SMUSSARE / ESCARIADOR DE CHANFROS / ЗЕНКОВКА С РУКОЯТКОЙ**

COD						
63776	Cu / ACERO / PLÁSTICO / INOX Cu / STEEL / PLASTIC / INOX	12,4	3	100	6	
63777		25		120		

Material: HSS (M2)

**FRESA CÓNICA / CONIC MILLING TOOL / FRAISE CONIQUE / SCHAFTFRÄSER KONISCH / FRESA CONICA /  
 FRESA CÓNICA / КОНИЧЕСКАЯ ЗЕНКОВКА С РУКОЯТКОЙ**

COD						
63778	Cu / ACERO / PLÁSTICO / INOX Cu / STEEL / PLASTIC / INOX	10-34	6	150	6	

Material: HSS



ESCARIADOR CÓNICO / TAPER REAMER / EBAYUREUR CONIQUE / HANDREIBAHLEN / SBAVATORE CONICO / ESCARIADOR CÓNICO / ЛЕНТОЧНАЯ ЗЕНКОВКА

COD		Crestas MAX Crests	gr.	Crests	gr.
63779	Cu / ACERO / PLÁSTICO / INOX	3-12	6	100	6
63780	Cu / STEEL / PLASTIC / INOX	10-25	8	120	



Material: HSS

RASQUETA / SCRAPPER / RACLOIR / ENTGRATER / RASCHIETTO / ESPÁTULA / ШАБЕР

COD		gr.	Crests	Building	Scraper
63376	CU / ACERO / PLÁSTICO / INOX CU / STEEL / PLASTIC / INOX	60	20	1	64449



COD		L	Crests
64008	CU / STEEL / PLASTIC / INOX	47	6
64446	BRASS / CAST IRON		
64447	CU / STEEL / PLASTIC / INOX	26	20
64448	BRASS / CAST IRON		
64449	CU / STEEL / PLASTIC / INOX	120	20



CEPILLOS PARA LIMPIEZA DE COBRE / COPPER CLEANING BRUSHES / BROSE DE NETTOYAGE POUR CUIVRE / KUPFER - REINIGUNGSBÜRSTE / SPAZZOLE PER RAME / ESCOVAS PARA LIMPIEZA DE COBRE / ЩЕТКИ ДЛЯ ЗАЧИСТКИ МЕДИ

COD		gr.	Crests	Building
63206	1/2"-3/4" INT. / EXT.	30	6	1



COD		gr.	Crests	Building
63207	1/2" INT. / EXT.	10	6	1



COD		gr.	Crests	Building
63208	1/2" INT.	5	6	1





## HERRAMIENTA PARA COBRE / TOOLS FOR COPPER / OUTILLAGE POUR LE CUIVRE / WERKZEUGE FÜR KUPFER / UTENSILI PER RAME / FERRAMENTAS PARA COBRE / ИНСТРУМЕНТ ДЛЯ МЕДИ

PARA TUBO DE COBRE RECOCIDO Y ALUMINIO / FOR SOFT COPPER & ALUMINIUM TUBING / POUR TUBE EN CUIVRE RECUIT ET ALUMINIUM / FÜR WEICHES KUPFER UND ALUMINIUM / PER TUBIRICOTTI E ALLUMINIO / PARA TUBO DE COBRE RECOZIDO E ALUMINIO / ДЛЯ МЯГКИХ МЕДНЫХ И АЛЮМИНИЕВЫХ ТРУБ

### CURVATUBOS / TUBE BENDERS / CINTREUSE À CUIVRE / BIEGGERÄT / CURVATUBI / DOBRADORES DO TUBO / ТРУБОГИБЫ

CURVATUBOS DE CARRACA / RATCHET TUBE BENDER / CINTREUSE ARBALETE / EINHAND-BIEGGERÄT / CURVATUBI A CRICCO / CURVADORA DE ROQUETE / АРБАЛЕТНЫЙ ТРУБОГИБ

KIT

COD			10	12	14	15	16	18	22	3/8	1/2	5/8	3/4	7/8
68165				●		●		●	●					
68166			●	●	●			●	●					
68167			●	●		●		●	●					
68168			●	●			●	●	●					
68169	●	●		●		●		●	●					
68170	●	●	●	●	●			●	●					
68171	●	●	●	●		●		●	●					
68172	●	●	●	●			●	●	●				●	●
68173	●	●								●	●	●	●	●



COD	
68118	1645





COD	
68128	8mm
68129	10mm
68130	12mm
68131	14mm
68132	15mm
68133	16mm
68134	18mm
68135	22mm

COD	
68136	3/8"
68137	1/2"
68138	5/8"
68139	3/4"
68140	7/8"

O.D.



KIT MULTICAPA / KIT MULTILAYER / KIT MULTICOUCHES / BIEGGERÄT SET / KIT MULTISTRATO / KIT MULTICAPA / НАБОР ДЛЯ МЕТАЛЛОПЛАСТИКА

COD			16	18	20	22
68162			●	●	●	
68161	●		●	●	●	
68228			●	●		●
68227	●	●	●	●		●



COBRE RECOCIDO  
SOFT COPPER  
CUIVRE RECUIT



COBRE RECUBIERTO  
COVERED COPPER  
CUIVRE PLASTIFIE



MULTICAPA  
MULTILAYER  
MULTICOUCHES



MUELLES CURVATUBOS / SPRING TUBE BENDERS / RESSORT À CINTRE / KUPFERROHR-AUSSENBIEGEFEDERN / MOLLE CURVATUBI / MOLAS CURVA TUBOS / ПРЖИННЫЕ ТРУБОГИБЫ

COD	6	1/4	8	3/8	10	7/16	12	1/2	14	15	16	3/4	22	15	1
68041	68048	68042	68049	68043	68050	68044	68051	68045	68046	68047	68054	68056	68055		
	55	75	70	110	100	115	110	155	145	180	195	195	200	230	



PARA TUBO DE COBRE RECOCIDO Y ALUMINIO / FOR SOFT COPPER & ALUMINIUM TUBING / POUR TUBE EN CUIVRE RECUIT ET ALUMINIUM / FÜR WEICHES KUPFER UND ALUMINIUM / PER TUBIRICOTTI E ALLUMINIO / PARA TUBO DE COBRE RECOZIDO E ALUMINIO / ДЛЯ МЯГКИХ МЕДНЫХ И АЛЮМИНИЕВЫХ ТРУБ

TENAZA CURVATUBOS / TUBE BENDER / PINCE À CINTRER / ZWEIHANDBIEGER / PINZA CURVATUBI / CURVADORA PARA TUBOS / ТРУБОГИБ

COD	O.D.	Kg.		
68144	10mm	0,3	1	
68145	12mm	0,6		
68146	14mm	0,9		
68147	15mm	1,4		
68148	16mm	1,7		
68149	18mm	2,1		



ALUMINIO / ALUMINIUM

TENAZA CURVATUBOS DE ACERO / STEEL TUBE BENDER / PINCE À CINTRER / ZWEIHANDBIEGER / PINZA CURVATUBI / CURVADORA PARA TUBOS / ТРУБОГИБ ДЛЯ СТАЛЬНЫХ ТРУБ

COD	O.D.	Kg.		
68210	12mm	1,3	82860	1
68211	15mm	2,7	82861	
68213	22mm	4,0	82863	



COD	O.D.	Kg.		
68215	12mm	1,3	82865	1
68216	15mm	2,7	82866	
68218	22mm	4,0	82868	



TENAZA CURVATUBOS / TUBE BENDER / PINCE À CINTRER / ZWEIHANDBIEGER / PINZA CURVATUBI / CURVADORA PARA TUBOS / ТРУБОГИБ

COD	O.D.	Kg.	
68113	15-22mm	3,4	1
68114	12-15-22mm	3,5	



COD	O.D.
81112	12mm
81113	15mm
81114	22mm
81115	12-15mm
81116	22mm



COD	O.D.	Gr.		
68010	6mm	-	500	1
68011	8mm	5/16"	600	
68012	10mm	-	900	
68013	12mm	-	950	
68014	14mm	-	1600	
68015	15mm	-	1700	
68016	16mm	5/8"	2200	
68005	-	1/4"	500	
68006	-	3/8"	900	
68008	-	1/2"	1600	



COD	O.D.	Gr.		
68110	1/8-3/16-1/4"	0-90°	140	1
68111	(1/4-5/16-3/8") (6-8-10mm)	0-180°	450	



3x1

**AVOCINADORES / FLARING TOOLS / APPAREIL À BATTRE LES COLLETS / BÖRDELGERÄT /  
 FLANGIATUBI / AVOCARDADORES / РАЗВАЛЬЦОВКИ**
**AVOCINADOR CONO EXCÉNTRICO CON CARRACA / ECCENTRIC CONE FLARING TOOL WITH RATCHET /  
 DUDGEONNIERE EXCENTRIQUE À CLIQUET / TAUMEL-BÖRDELGERÄT MIT RATSCHEN / FLANGIATUBI CON  
 CRICCHETTO / AVOCARDADOR CONO EXCÉNTRICO COM ROQUETE / РАЗВАЛЬЦОВКА С ЭКСЦЕНТРИЧЕСКИМ КОНУСОМ С  
 ТРЕЩЕТКОЙ**

COD	O.D.	90°	Kg.	
68096	1/4-5/16-3/8-1/2-5/8-3/4"	●	1,5	1
68095	6-8-10-12-14-15-16mm			
68098	1/4-5/16-3/8-1/2-5/8-3/4" 6-8-10-12-14-15-16mm		2,1	

**AVOCINADOR CONO EXCÉNTRICO / ECCENTRIC CONE FLARING TOOL / DUDGEONNIERE EXCENTRIQUE /  
 TAUMEL / FLANGIATUBI CONO ECCENTRICO / AVOCARDADOR CONO EXCÉNTRICO / РАЗВАЛЬЦОВКА С  
 ЭКСЦЕНТРИЧЕСКИМ КОНУСОМ**

COD	O.D.	90°	Kg.	
68087	1/4-5/16-3/8-1/2-5/8-3/4"	●	1,4	1
68086	6-8-10-12-14-15-16mm			
68091	1/4-5/16-3/8-1/2-5/8-3/4" 6-8-10-12-14-15-16mm		2,0	

**AVOCINADOR AJUSTABLE / ADJUSTABLE FLARING TOOL / DUDGEONNIERE REGLABLE / UNIVERSAL-  
 BÖRDELGERÄT / FLANGIATUBI REGOLABILE / AVOCARDADOR AJUSTAVEL / РЕГУЛИРУЕМАЯ РАЗВАЛЬЦОВКА**

COD	O.D.	90°	gr.	
68090	5mm-16mm 3/16" - 5/8"	●	800	1

**AVOCINADOR DE TORRETA / COMPACT FLARING TOOL / DUDGEONNIERE COMPACTE / КОМПАКТ BÖRDELGERÄT,  
 AUFKLAPPBAR / FLANGIATUBI A TORRETTA / AVOCARDADOR DE TORRETA / КОМПАКТНАЯ РАЗВАЛЬЦОВКА**

COD	O.D.	90°	Kg.	
68017	3/16-1/4-5/16-3/8-1/2-5/8"	●	1	1
68018	6-8-10-12-14-15mm			

**AVOCINADOR / FLARING TOOL / APPAREIL À BATTRE LES COLLETS / BÖRDELGERÄT / FLANGIATUBI /  
 AVOCARDADOR / РАЗВАЛЬЦОВКИ**

COD	O.D.	90°	gr.	
68001	3/16-1/4-5/16-3/8-7/16-1/2-5/8"	●	950	1
68003	4-4,75-6-8-10-12-14mm			



EXPANDIDORES / EXPANDING TOOLS / PINCES À EMBOITURE / EXPANDER / ESPANSORI / EXPANDIDORES / МУФТИРУЮЩИЕ ИНСТРУМЕНТЫ

### EXPANKIT

COD	O.D.			Kg.		
68204	12-15-22-28mm	3-32	Ø40	3,0	1	
68205	12-14-18-22mm					
68206	12-15-18-22mm					
68207	1/2-5/8-3/4-1"			3,1		
68209	3/8-1/2-5/8-3/4-7/8"					
68220	1/2-3/4-1"			3,0		
68221	12-14-16-18-22mm			-		2,9
68223	10-12-14-16-18mm			-		2,8
68224	12-14-16-18mm			-		2,7
68225	12-14-16-18-22mm			-		2,8



COD		Kg.		
68175	1	1,3	1	1



COD	O.D.	COD	O.D.	Dr.		
68177	10mm	68190	3/8"	125	8	1
68178	12mm	68191	1/2"	130		
68179	14mm	68192	5/8"	135		
68180	15mm	68193	3/4"	140		
68181	16mm	68194	7/8"			
68182	18mm	-	-	145		
68184	22mm	-	-	150		
-	-	68195	1"	160		
68186	28mm	68196	1.1/8"	270		
68188	35mm	68198	1.3/8"	400		
68189	42mm	-	-	430		
-	-	68200	1.5/8"	480		



### SWAGING KIT

COD	O.D.			Kg.	
68060	1/8-3/16-1/4-5/16-3/8-7/16-1/2-5/8-3/4"	3/16-1/4-5/16-3/8-1/2-5/8-3/4"	1/8-1.1/4"	2,8	1



KIT FRIGORISTA / KIT REFRIGERATION / KIT FRIGORISTE / KIT KÜHLUNG / KIT FRIGORISTI / KIT FRIGORISTA / НАБОР ДЛЯ ХОЛОДИЛЬЩИКА

COD	O.D.			Kg.	
68052	4-4,75-6-8-10-12-14mm	10-12-14-16mm	3,0-32mm	2,3	1
68053	3/16-1/4-5/16-3/8-1/2-5/8"	5/16-3/8-1/2-5/8"	1/8-1.1/8"		





## HERRAMIENTA PARA COBRE / TOOLS FOR COPPER / OUTILLAGE POUR LE CUIVRE / WERKZEUGE FÜR KUPFER / UTENSILI PER RAME / FERRAMENTAS PARA COBRE / ИНСТРУМЕНТ ДЛЯ МЕДИ

PEINE PARA ALETAS 6 EN 1 / 6 IN 1 FIN COMB / PEIGNES POUR LAMES 6 EN 1 / 6 IN 1 MESSKAM / PETTINI PER ALETTE 6 IN 1 / PENTES DE ALHETAS 6 EM 1 / 6 В 1 ГРЕБЕНЫ ДЛЯ ЛЬНА

COD			
63751	8-9-10-12-14-15	70	1



PEINE PARA ALETAS METÁLICO / STAINLESS STEEL FIN COMB / PEIGNES POUR LAMES MÉTALLIQUES / MESSKAM ROSTFREI / PETTINI PER ALETTE IN METALLO / PENTES DE ALHETAS METALICOS / ГРЕБЕНЫ ДЛЯ ЛЬНА ИЗ НЕРЖАВЕЮЩЕЙ СТАЛИ

COD		
63752	30	6



TENAZA GRIP PINZATUBOS / PINCH OFF GRIP PLIER / PINCE ÉTAU POUR TUBES / SCHNEIDGRIPZANGE / PINZA GRIP PER TUBI / ALICATES DE GRIFE DE SELAR PARA REFRIGERAÇÃO / КЛЕЩИ С ПЛАВНОЙ РЕГУЛИРОВКОЙ

COD					
63753	7"	5/16" - 8,0 mm	0,3	6	1



LLAVE DE CHICHARRA / RATCHET WRENCH / PINCE À CLIQUET / RATSCHENSCHLÜSSEL / CHIAVE A CRICCO / CHAVES DE ROQUETE / ТРЕЩЕТКА

COD					
63754	1/4", 3/8", 3/16", 5/16"	-	95	12	1



COD					
63755	1/4", 3/16"	1/2", 9/16"	160	12	1



ENSANCHADORES DE GOLPE / SWAGING PUNCHES / CHASSES GOUPILLES À EMBOITURE / KLEMM DURCHSCHLAG / CALIBRATORE PER TUBI / PUNÇÕES PARA AVOCARDAR / ПРОБОЙНИКИ

SET

COD			
63756	1/4", 5/16", 3/8", 1/2", 5/8"	550	6





ENSANCHADOR DE GOLPE 3 EN 1 / 3 IN 1 SWAGING PUNCH / CHASSES GOUPILLES À EMBOITURE 3 EN 1 / 3 IN 1 KLEMM DURCHSCHLAG / CALIBRATORI PER TUBI 3 IN 1 / PUNÇÕES PARA ABOCARDAR 3 EM 1 / 3 В 1 ПРОБОЙНИКИ

COD	O.D.	gr.		
63757	1/2", 5/8", 7/8"	550	6	1



ENSANCHADOR DE GOLPE 5 EN 1 / 5 IN 1 SWAGING PUNCH / CHASSES GOUPILLES À EMBOITURE 5 EN 1 / 5 IN 1 KLEMM DURCHSCHLAG / CALIBRATORI PER TUBI 5 IN 1 / PUNÇÕES PARA ABOCARDAR 5 EM 1 / 5 В 1 ПРОБОЙНИКИ

COD	O.D.	gr.		
63758	1/4", 5/16", 3/8", 1/2", 5/8"	280	6	1



PINZA CORTACAPILARES / CAPILLARY TUBE CUTTER / PINCE COUPE CAPILAIRES / MIKROSTRIPPER ZANGE / PINZA TAGLIACAPILLARI / ALICATES CORTA CAPILARES / ТРУБОРЕЗ ДЛЯ КАПИЛЯРНЫХ ТРУБОК

COD	O.D.	gr.		
63759	1-3 mm	85	6	1



PARA LAVABO / BASIN TOOLS / OUTILS LAVABO / WERKZEUG FÜR WASCHEBECKEN / UTENSILI PER LAVABI / FERRAMENTA PARA LAVABO / ИНСТРУМЕНТЫ ДЛЯ РАКОВИН, РАДИАТОРОВ  
LLAVE PARA RADIADORES / RADIATOR SPUD WRENCH / CLÉ DE MONTAGE / SPEZIAL RATSCHKE FÜR HEIZKÖRPER / CHIAVE DI MONTAGGIO / CHAVE DE MONTAGEM / РАДИАТОРНЫЙ КЛЮЧ

KIT

COD	CAP	gr.	
61167	3/8-1/2-3/4-1"	490	1

61168	
61169	



TENAZA DE SIFÓN / SYPHON PLIER / PINCE SANIGRIP / SIPHONZANGE / PINZA PER SIFONI / ALICATE DE SIFAÕ / КЛЕЩИ ДЛЯ СИФОНОВ

COD	O.D.	L	gr.		
62136	62mm-2"	10"	300	6	1

Fundas blandas / Soft sleeves / Mâchoires de protection en plastique molle

COD	O.D.	L	gr.		
62157	62mm-2"	10"	300	6	1

Fundas duras / Hard sleeves / Mâchoires de protection en plastique dur



## HERRAMIENTA PARA COBRE / TOOLS FOR COPPER / OUTILLAGE POUR LE CUIVRE / WERKZEUGE FÜR KUPFER / UTENSILI PER RAME / FERRAMENTAS PARA COBRE / ИНСТРУМЕНТ ДЛЯ МЕДИ

KIT REPARADOR DE GRIFOS / VALVE RESEATER / KIT PLOMBIER / WASSERHAHN-FRÄSGERÄT / KIT APPARECCHI PER RUBINETTI / KIT REPARADOR DE TORNEIRAS / НАБОР ДЛЯ ПРИТИРКИ КРАНОВ

COD		gr.	
68059	10-12-13-14-15-16	380	1

COD		gr.	
68058	10-12-13-14-15-16	400	1



PARA LAVABO / BASIN TOOLS / OUTILS LAVABO / WERKZEUG FÜR WASCHBECKEN / UTENSILI PER LAVABI / FERRAMENTA PARA LAVABO / ИНСТРУМЕНТЫ ДЛЯ РАКОВИН, РАДИАТОРОВ

LLAVES DE LAVABO / BASIN WRENCHES / CLÉS LAVABO / STANDHAHNMUTTERNSCHLÜSSEL / CHIAVI PER LAVABI / CHAVES DE LAVABO / КЛЮЧ ДЛЯ РАКОВИН

### STANDARD

COD		L	gr.		
61008	10+32	288	490	6	1

### TELESCOPIC

COD		L	gr.		
61009	10+32	460	700	6	1

COD		L	gr.		
61000	15+32	240	500	6	1

COD		L	gr.		
61325	1"+1.1/4"	240	300	6	1

NIVEL PARA LAVABOS / PLUMBERS BASIN LEVEL / DIMA REGOLABILE PER LAVABO / NORMABSTAND WASSERWAAGE / NIVEAU LAVABO / NÍVEL DA BACIA DOS CANALIZADOR / УРОВЕНЬ САНТЕХНИЧЕСКИЙ

COD		L mm	mm/m CAP	gr.		
65780	90+220	300	0,5 1/2"	400	1	1

