

※To prevent irregular winding of the wire rope around the drum, keep the fleet angle 2 degrees or less.

Please install the pulley 1800mm or more away from the drum on the center line of the drum.

※The value of specified "Wire Rope Tension" on this drawing is for the standard layer or less.

The value of the "Wire Rope Tension" must be decreased accordance with the ratio of the actual winding layers, if it exceeded.

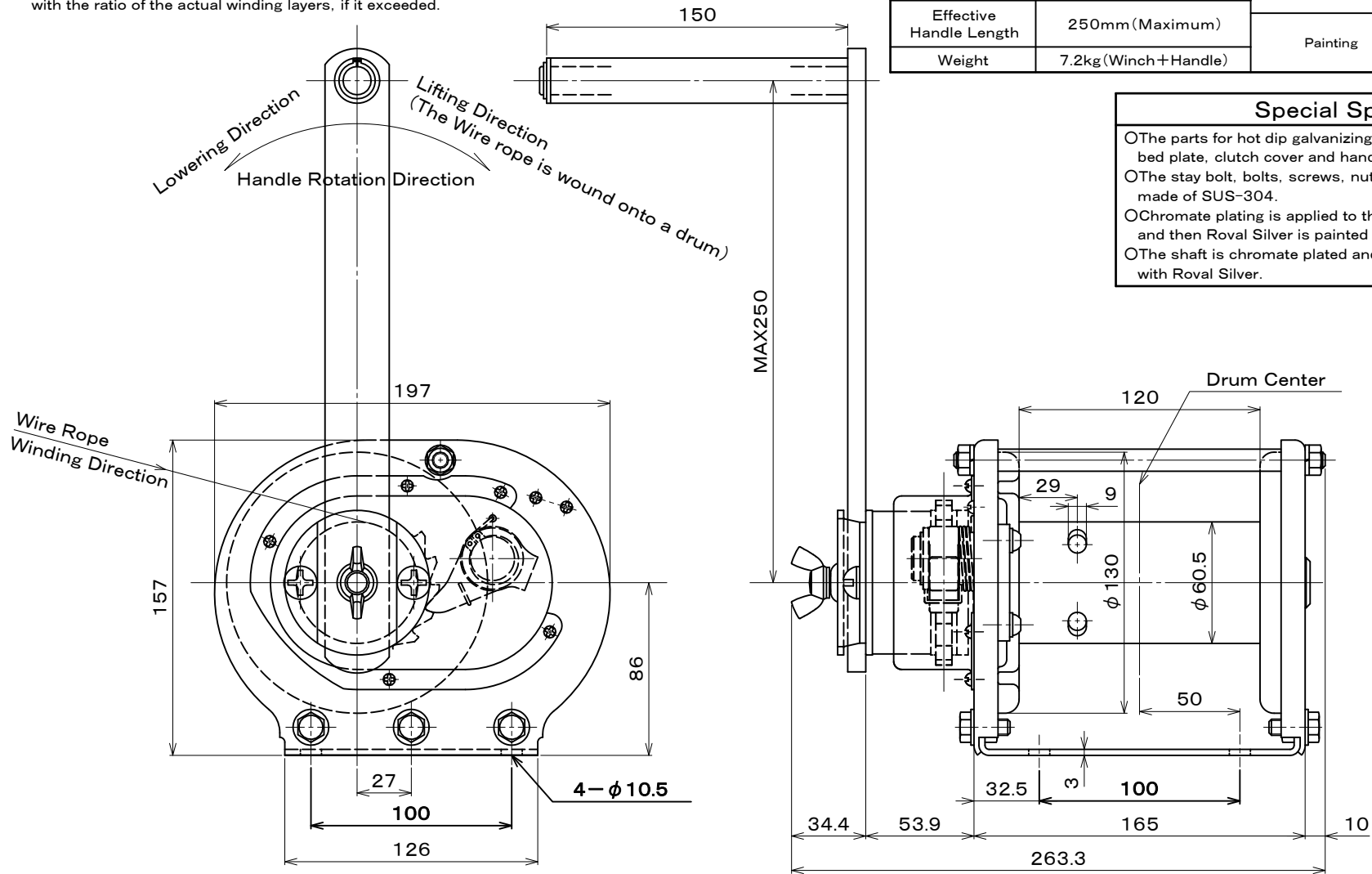

### Specifications

(The wire rope composition is a manufacturer recommendation.)

Load Rating	980N (= 100kgf)	Handle Force	Handle Length	Number of Wire Rope Winding Layer
Wire Rope Tension	4th Layer (Standard Layer)		250mm	
Drum Capacity	Wire Rope 6-Layer Windings φ 5mm (6 × 19) × 35m	Standard Accessories	Wire Rope Tension	3rd Layer 187N (= 19.0kgf)
Gear Ratio	1/1		980N	4th Layer 208N (= 21.2kgf)
Effective Handle Length	250mm (Maximum)	Painting	One Handle	
Weight	7.2kg (Winch + Handle)		One Hex Wrench for Anchoring the Wire Rope	

### Special Specifications

- The parts for hot dip galvanizing are : side frame A, side frame B, bed plate, clutch cover and handle arm.
- The stay bolt, bolts, screws, nuts, retaining ring and spring are made of SUS-304.
- Chromate plating is applied to the stopper, clutch and handle holder and then Roval Silver is painted over it.
- The shaft is chromate plated and only the tip of the shaft is painted with Roval Silver.

△ x	..	図面番号 / DRAWING No.	GM1GSSI-160729-01E	改訂番号 / REVISION No.	00	お客様 / CUSTOMER	符号 / MARK	項目 / PARTICULARS	材料 / MATERIAL	数量 / QTY	単体 / 合計 / PER ONE / TOTAL	備考 / REMARKS
△ x	..	承認 / APPROVED	検図 / CHECKED	作成 / DRAWN	図面名 / TITLE	MAXPULL WINCH CORROSION RESISTANT AND SALT RESISTANT (HOT DIP GALVANIZING) STOPPER ARMLESS ROTATING MODEL GM-1-GS-SI	投影法 / PROJECTION METHOD	第三角法 / THIRD ANGLE PROJECTION	尺度 / SCALE	台数 / QTY		
△ x	..	設計部	設計部	設計部								
△ x	..	'16.08.01	'16.08.01	'16.07.29								
改訂 / REVISION	..	米澤	松嶺	武松								

