

IOT BASED CAR PARKING SYSTEM

Aishwaryaa P¹, Ananya H S², Keerthana S³, Nirranjan M G⁴

Mrs M S Sunitha Patel Assistant Professor

ATME College of Engineering, Mysuru¹²³⁴

(Email: aishwaryaaprasadjain@gmail.com, ananyas1997@gmail.com, keerthana0307@gmail.com, mgniranjan4897@gmail.com, mssunithapatel@gmail.com)

Abstract— In this modern world, the number of vehicles is rapidly growing once every day, but there is a crisis for space to park these vehicles. To create a optimize solution for this crisis “An IOT Based Car Parking System” prototype helps the user to locate a parking space for his/her vehicle through a mobile application. The user can enquiry on availability of parking space nearest to his/her location without struggle to find a halting extent and without thinking about where there is an empty parking space with the help of mobile application that shows the number of vacant slots in any parking area and navigate the driver to that location. Also this prototype is being implemented using sensor circuit, IR sensors is used to find the presence of vehicle in respective parking area and all details are accessed remotely by using IOT. This system uses less human interaction which increases flexibility and security.

Keywords—*Internet of Things, car parking, smart city.*

INTRODUCTION

The Internet of things (*IoT*) is the network of physical devices, vehicles, home appliances, and other items embedded with electronics, and connectivity which enables these things to connect, collect and exchange data or the Internet of things (*IoT*) refers to the concept of extending Internet connectivity beyond conventional computing platforms such as personal computers and mobile devices. Kevin Ashton is known as “the father of IOT” for coining and having the vision of internet connected things back in 1999. Kevin Ashton who was working in supply chain optimization, wanted to attract senior management’s attention to a new exciting technology called RFID (Radio Frequency Identification). Because the internet was the new trend in 1999 and because it somehow made sense, he called his presentation “Internet of Things”. Cisco Systems estimated that IOT was “born” in 2008.

Defining the Internet of things as “simply the point in time when more ‘things or objects’ were connected to the Internet than people”. Internet of Things plays a vital role in the creation of Smart Cities. The most important factors for the emergence of smart cities are cozy parking facilities and efficient transportation and management. The idea of creating a Smart City is now becoming possible with the emergence of the Internet of Things. One of the important considerations of being a smart city is the Smart Parking facility. Finding a parking space to park their vehicle has ended up being a disappointing issue to the drivers all the time. This leads to

many problems such as, traffic congestion, limited car parking facilities, road safety and excess consumption of fuel and so on. In order to overcome with this crisis, many technologies evolved but it didn’t benefit all varying with expense, efficiency, power, accuracy and other factors. Besides, number of vehicles rapidly grows once every day. It has been seen that the drivers struggle to find a halting extent without thinking about where parking space is free. Thus it is highly required to develop an automated smart parking management system that would help the driver to find out some suitable parking space. Problems pertaining to parking and traffic congestion can be solved if the drivers can be informed in advance about the availability of parking spaces at and around their intended destination. An “IOT Based Smart Parking System” helps a driver to locate a suitable parking space for his/her vehicle with respect to their location.

LITERATURE SURVEY

Internet of Things plays a vital role in the creation of Smart Cities. The most important factors for the emergence of smart cities are comfortable parking facilities and efficient transportation and management. Due to the advancements in the sensor technology and the low-cost features of the Embedded Systems, there are many innovative parking ideas that have been developed.

Significant number of smart parking systems based on various technologies like Radio Frequency Identification (*RFID*), wireless sensor network (*WSN*), Bluetooth, Wi-Fi, ZigBee etc. as well as agent based technologies and image processing techniques have been proposed in the literature over the past few years.

Among these, in [1] a prototype based on Raspberry pi and pi camera is presented, where the pi-camera is used to detect the empty parking spaces and sends the data to the server, the stored data is accessed by users. The [2] presents the idea of reserving the parking lot through the mobile application as per their vehicle’s width via Wi-Fi or Internet. Once the car approaches the parking area the vehicle number is verified through pi camera if it is same as the number entered through the application, that vehicle is allowed inside.

The [8] presents the implementation of smart parking model in has been implemented using Infrared sensors that send the status of the parking slot to the microcontroller, the microcontroller processes the data and the user can get the information about the status of the slots from the website.

The parking system [28] uses WIFI network, infrared devices, and parking belts to detect miss parked cars. The mobile

application is used to reserve a parking lot and the entrance booth will validate the reservation. If the parking spot is validated, a direction-related guidance will be uploaded to the car for finding the reserved spot. The infrared device, lights, and parking belt will work together to detect and prevent miss parking. The Bluetooth communication will be activated when the front wheel presses the belt. The tamper-resistant device (TRD) and belt validate reservation confirmation as necessary. The infrared device is used to validate whether the car is parked instead of using the slot for a temporary purpose.

The ultrasonic sensor nodes are used in [9] for detecting presence of vehicle within the parking lot, a Light Emitting Diode (LED) for indicating the status of parking lot (reserved or not reserved), microcontroller Arduino MEGA 2560, an alarm IC module to create warning sound in case of improper parking, a camera module for taking snapshot of the vehicle's license plate and IEEE 802.11 b/g/n compatible wireless module for communicating with the local parking management server. A GSM module is attached with the local parking management server via some serial port for sending SMSs to the site officer as well as the vehicle's driver.

The Passive Infrared (PIR) and Ultrasonic Sensors are used [27] to sense the parking area and determine whether a parking lot is vacant or not. The ultrasonic sensors are used to detect the presence of a car. The ultrasonic sensors are wirelessly connected to raspberry pi using the ESP8266 chip. The user through the mobile application will reserve the parking lot, pay according to the time which he/she wishes to park and once the vehicle parks the user has to confirm it's parking in the mobile application. If the driver overshoots the parking time a notification is sent where the driver can extend the parking time and pay for it.

ARCHITECTURE

The main blocks of the IoT based car parking system are:

- Arduino microcontroller
- Wi-Fi modem(ESP8266)
- IR sensors
- DC motor
- Cloud storage
- H bridge(L298)

A. Arduino microcontroller

Arduino is an open-source electronics platform based on easy-to-use hardware and software. Arduino boards are able to read inputs - light on a sensor, a finger on a button, or a Twitter message - and turn it into an output - activating a motor, turning on an LED, publishing something online.

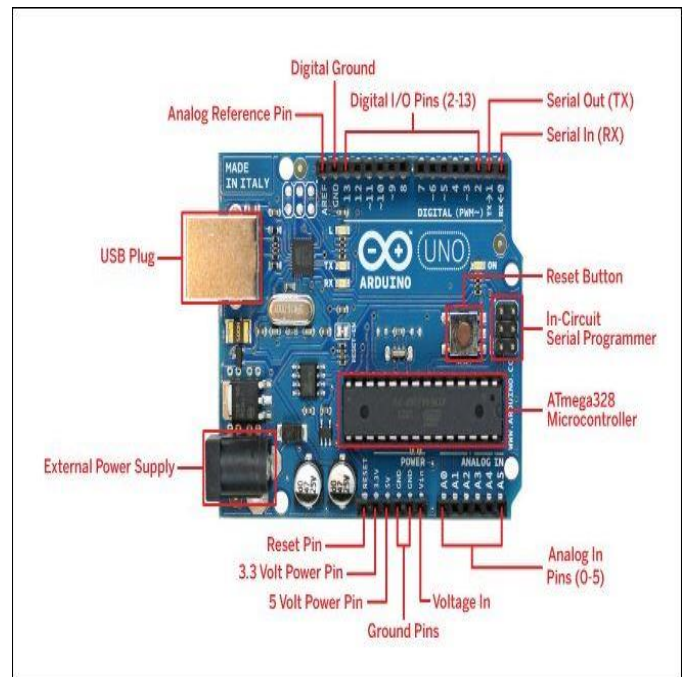

Fig 3.1 Pin diagram of arduino uno microcontroller

The microcontroller board is based on the ATmega328P. It has fourteen digital input/output pins (of which six can be used as PWM outputs), six analog inputs, a 16 MHz quartz crystal, a USB connection, a power jack, an ICSP header and a reset button. It contains everything needed to support the microcontroller; simply connect it to a computer with a USB cable or power it with an AC-to-DC adapter or battery to get started. This prototype is implemented using infrared sensor which is connected to the digital pins of the microcontroller are used. The data from the sensors are collected and processed in the Arduino IDE. This data is nothing but the number of car that have been entered the parking area and the remaining parking lots that can be occupied by other drivers. The processed data is made available to the user through the mobile application which fetches this data from the cloud storage confirm that you have the correct template for your paper size. This template has been tailored for output on the A4 paper size. If you are using US letter-sized paper, please close this file and download the file "MSW_USltr_format".

B. Cloud storage

Cloud storage is a platform that is designed to store and process data. The platform is built to take in the massive volumes of data generated by devices, sensors, websites, applications, customers and partners and initiate actions for real-time responses. IoT Cloud can provide business users with much a much more comprehensive and integrated perspective on customers, without requiring technical expertise or the services of a data analyst. The platform can take in billions of events a day and users can build rules that specify events to act on and what actions to take. Cloud computing has entered the mainstream of information technology, providing scalability in delivery of enterprise applications and Software as a Service (SaaS). Companies are now transferring their information operations

to the cloud. Many cloud providers, allow the users data to either transferred via your traditional internet connection or via a dedicated direct link. The benefit of a direct link into the cloud will ensure that your data is uncontended and that the traffic is not crossing the internet and the Quality of Service can be controlled. The cloud storage in the project is used to store the number of vacant parking lots available in the parking area. This data is continuously updated to the cloud from which the mobile application fetches the number of vacant parking lots that will be displayed in the application. This will help the driver to decide which parking area he can choose to park his vehicle.

C. Wi-Fi Module ESP8266

ESP8266 module is low cost standalone wireless transceiver that can be used for end-point IOT developments. ESP8266 is Wi-Fi enabled system on chip (SoC) module. It is mostly used for development of IOT (*Internet of Things*) embedded applications. It employs a 32-bit RISC CPU based on the Tensilica Xtensa L106 running at 80 MHz (or overclocked to 160 MHz). It has a 64 KB boot ROM, 64 KB instruction RAM and 96 KB data RAM. External flash memory can be accessed through SPI. To communicate with the ESP8266 module, microcontroller needs to use set of AT commands. Microcontroller communicates with ESP8266-01 module using UART having specified Baud rate.

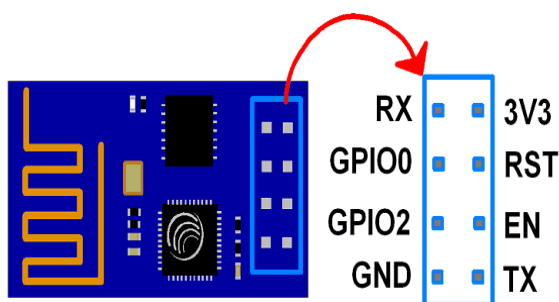

Fig 3.2 The pin diagram of ESP8266 Wi-Fi module

The Wi-Fi module has the following pins:

- 1) 3V3: 3.3 V Power Pin.
- 2) GND: Ground Pin.
- 3) RST: Active Low Reset Pin.
- 4) EN: Active High Enable Pin.
- 5) TX: Serial Transmit Pin of UART.
- 6) RX: Serial Receive Pin of UART.
- 7) GPIO0 & GPIO2: - General Purpose I/O Pins. These pins decide what mode (*boot or normal*) the module starts up in. It also decides whether the TX/RX pins are used for Programming the module or for serial I/O purpose. The data collected from the sensors are

processed in the microcontroller and it should be uploaded to the cloud and to communicate from microcontroller to cloud this Wi-Fi module is used.

II. IMPLEMENTATION

An IoT system consists of sensors, actuators, microcontroller and modem. Two or more such systems can be connected to each other or to cloud storage or to processing units. The data collected from these systems are stored, processed and result will be provided to users.

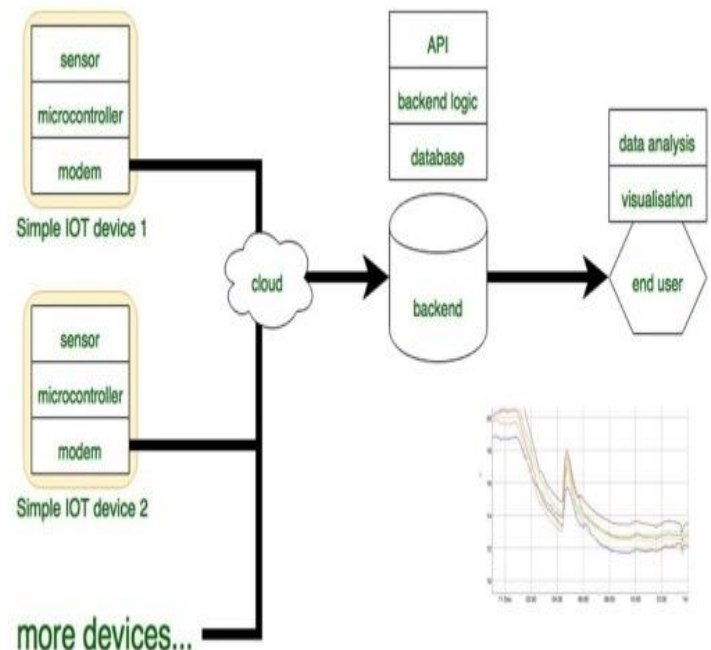

Fig 4.1 Architecture of IoT

Smart city is one of the important applications of Internet of Things. The idel of creating a Smart City is now becoming possible with the emergence of the Internet of Things. Smart parking system is an important facility of a smart city. Finding a parking lot to park their vehicle has always been a disappointing issue to the drivers. This leads to many problems such as traffic congestion, road safety and excess consumption of fuel and so on. In order to overcome these problems, many technologies evolved but it didn't benefit all varying with expense, efficiency, power, accuracy and other factors. Problems pertaining to parking and traffic congestion can be solved if the drivers can be informed in advance about the availability of parking spaces near their location. This system helps a driver to locate a suitable parking space for his/her vehicle with respect to their location.

The prototype mainly consists of the following components

- 1) Android Mobile Application
- 2) Slot and Vehicle detection using Infrared sensors(IR Sensor).
- 3) Payment through QR code scanning
- 4) Database (Cloud)
- 5) Arduino microcontroller and IDE
- 6) Navigation to parking area

The system helps user to check for the empty slot availability in the parking area through an application and to navigate to the location. IR sensors will check the availability of each slot and update the total number of empty slot details to cloud. Once a vehicle reaches the entrance of the parking area, IR sensors will check whether the vehicle is a car or not. If the vehicle is not a car, entrance gate will not be opened and car will not allow entering the parking area. If the vehicle is a car then slots will be checked for availability, and if empty slot is available the gate will be opened and car will be allowed to park, if empty slot is not available car will not be allowed. Details of availability of empty slot will be continuously updated to cloud so that application can display correct information to users.

placement of sensors at different distance will help to verify whether the vehicle near the entrance is car or not. If it is a car, the availability of the vacant slots is checked, if there is a vacant slot, then the gate will be opened allowing the vehicle inside to park.

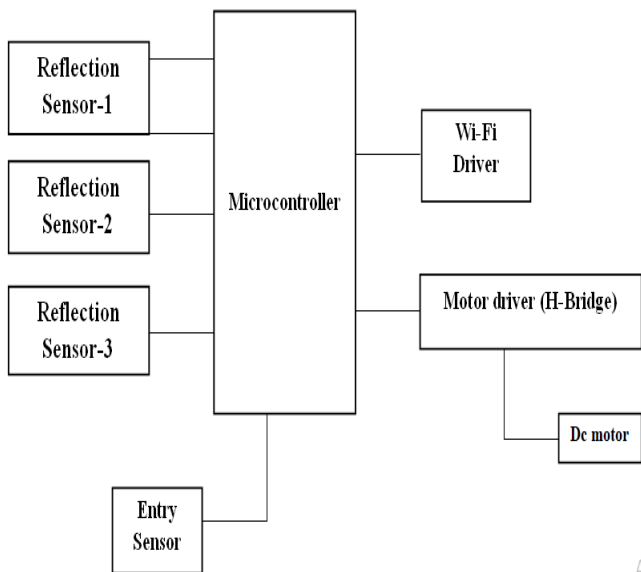

Fig 4.2 Conceptual System Design

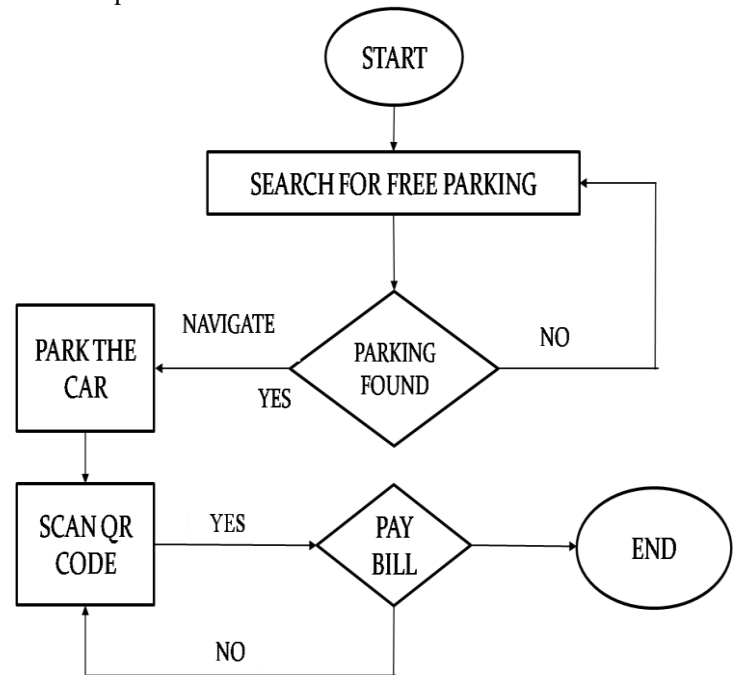

Fig 4.3 Flow chart diagram

The above mentioned procedure for booking a slot and parking a car in that very slot is explained with the help of the flowchart:

When the driver wants to exit the parking area, he has to drive near the exit, where there is a QR code near the gate which the driver has to scan using the mobile application. If it is properly scanned, it will display the amount that has to be paid for parking the car. Once the payment is successful, the exit gate will be automatically opened allowing the driver to exit from the parking area.

Following are the steps that a driver needs to follow in order to park their car using this parking system.

- Step 1: Install the smart parking application on the mobile device.
- Step 2: Search for a parking area on and around their destination.
- Step 3: Select a particular parking area.
- Step 4: Check for the number of vacant parking lots in that particular parking area.
- Step 5: If there is a vacant parking lot, the driver can navigate to that parking area.

When the driver reaches the parking area, there are three infrared sensors placed near the entrance, in which, one infrared sensor is placed near the gate and the second infrared sensor is placed at the minimum distance of the car and the third infrared sensor is placed at a quite far distance. This

RESULT AND CONCLUSION



Fig 5.1 The home screen of the android application



Fig 5.2 Options given to the user

The application is used for following:

- A. To search for empty car parking slot nearest to his/her location.
- B. Checks for number of empty parking slot.
- C. Navigate to the car parking area.
- D. Payment can be done through scanning QR code while leaving parking slot.

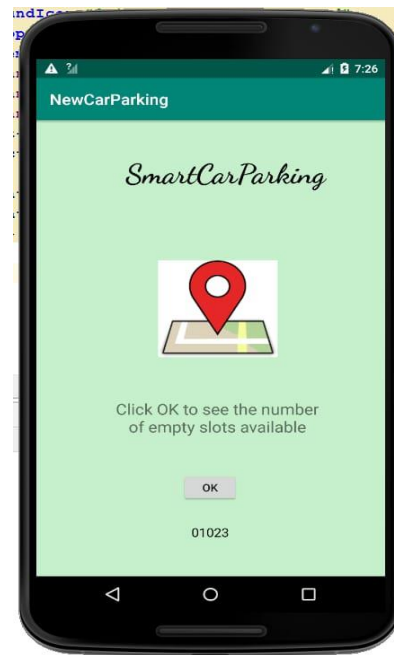

Fig 5.3 Application shows the number of parking space available.

This application helps user to know where the empty parking area is available nearest to his or her location and also shows the number of parking space count.

The main benefit of the system is time saving and It can also provide sustainable parking management in an eco-friendly manner. There is less maintenance cost for this system so it helps the property developer in cost saving and also It provides security to the parking ground, reduces the hassle in parking grounds and traffic jam. It will also encourage Automation Engineering in our country which will make advancement in increasing usage of technology. And developing the car parking solutions within a city solves the vandalism problem and this system benefits by avoiding the wastage of time. Therefore we should implement this project and help to develop our city.

REFERENCES

- [1] Mr. Basavaraju S R.” Automatic Smart Parking System using Internet of Things (IOT)” International Journal of Scientific and Research Publications
- [2] E. Cassin Thangam², M. Mohan¹, J. Ganesh³, C.V. Suresh⁴ “Internet of Things (IoT) based Smart Parking Reservation System using Raspberry-pi” International Journal of Applied Engineering Research ISSN 0973-4562 Volume 13, Number 8 (2018) pp. 5759-5765
- [3] Prof.S.S.Thorat, Ashwini M, Akanksha Kelshikar, Sneha Londhe, Mamta Choudhary “ IoT Based Smart Parking System Using RFID” International Journal of Computer Engineering In Research Trends Volume 4, Issue 1, January -2017, pp. 9-12 ISSN (O): 2349-7084

- [4] Abhirup Khanna, Rishi Anand "IoT based Smart Parking System" 2016 International Conference on Internet of Things and Applications (IOTA) Maharashtra Institute of Technology, Pune, India 22 Jan - 24 Jan, 2016 (Conference Paper)
- [5] W. WANG, Y. SONG*, J. ZHANG and H. DENG "AUTOMATIC PARKING OF VEHICLES: A REVIEW OF LITERATURES" International Journal of Automotive Technology, Vol. 15, No. 6, pp. 967-978 (2014) DOI 10.1007/s12239-014-0102-y
- [6] Mahendra B M, Dr Savita Sonoli and Nagaraj bhat "IoT Based Sensor Enabled Smart Car Parking for Advanced Driver Assistance System" 2017 2nd IEEE International Conference On Recent Trends in Electronics Information & Communication Technology (RTEICT), May 19-20, 2017, India.
- [7] Ling Hu and Qiang Ni, *Senior Member, IEEE* "IoT-Driven Automated Object Detection Algorithm for Urban Surveillance Systems in Smart Cities" IEEE INTERNET OF THINGS JOURNAL, VOL. 5, NO. 2, APRIL 2018.
- [8] Y Raghavender Rao. Automatic Smart Parking System using Internet of Things (IOT)
- [9] Pampa Sadhukhan. An IoT-based E-Parking System for Smart Cities
- [10] Etqad Khan, Dipesh Garg, Rajeev Tiwari and Shuchi Upadhyay "Automated Toll Tax Collection System using Cloud Database"
- [11] C. W. Hsu, M. H. Shih, H. Y. Huang, Y. C. Shiue, S. C. Huang, "Verification of smart guiding system to search for parking space via DSRC communication", Proc. 12th Int. Conf. ITS Telecommun. (ITST), pp. 79-80, 2012.
- [12] Zhao, X., Zhao, K., & Hai, F. (2014). An algorithm of parking planning for smart parking system. Proceeding of the 11th World Congress on Intelligent Control and Automation. doi:10.1109/wcica.2014.7053556
- [13] S Mendiratta, D Dey and D Rani Sona, "Automatic car parking system with visual indicator along with IoT," 2017 International conference on Microelectronic Devices, Circuits and Systems (ICMDCS).
- [14] T. N. Pham, M. F. Tsai, D. B. Nguyen, C. R. Dow and D. J. Deng, "A Cloud-Based Smart-Parking System Based on Internet-of-Things Technologies," in IEEE Access, vol. 3, no. , pp. 1581-1591, 2015.
- [15] A. I. Niculescu, B. Wadhwa and E. Quek, "Technologies for the future: Evaluating a voice enabled smart city parking application," 2016 4th International Conference on User Science and Engineering (i-USEr), Melaka, 2016, pp. 46-50.
- [16] A. Roy, J. Siddiquee, A. Datta, P. Poddar, G. Ganguly and A. Bhattacharjee, "Smart traffic and parking management using IoT," 2016 IEEE 7th Annual Information Technology, Electronics and Mobile Communication Conference (IEMCON), Vancouver, BC, 2016, pp. 1-3.
- [17] K.Hassoune, W. Dachry, F. Moutaouakkil and H. Medromi, "Smart parking systems: A survey," 2016 11th International Conference on Intelligent Systems: Theories and Applications (SITA), Mohammedia 2016, pp. 1-6.
- [18] B M Mahendra, Savita Sonoli, Nagaraj Bhat, Raju, T. Raghu "IoT based sensor enabled smart car parking for advanced driver assistance system" 2017 2nd IEEE International Conference on Recent Trends in Electronics, Information & Communication Technology (RTEICT).
- [19] S Adarsh and S Mohamed Kaleemuddin and Dinesh Bose and K I Ramachandran "Performance comparison of Infrared and Ultrasonic sensors for obstacles of different materials in vehicle/robot navigation applications" IOP Conference Series: Materials Science and Engineering,149 (2016) 012141 doi:10.1088/1757-899X/149/1/012141
- [20] Sarthak Mendiratta, Debopam Dey, Deepika Rani Sona, "Automatic car parking system with visual indicator along with IoT" 2017 International conference on Microelectronic Devices, Circuits and Systems (ICMDCS).
- [21] Shyam Ravishankar, Nrithya Theetharappan, "Cloud connected smart car park" 2017 International Conference on I-SMAC (IoT in Social, Mobile, Analytics and Cloud) (I-SMAC).
- [22] Zhongsheng Wang, Zhichao Lian, Kang Han, "Designing of Intelligent Parking Lot Based on MQTT" 2017 International Conference on Computer Network, Electronic and Automation (ICCNEA)
- [23] M. Idris, Y. Leng, E. Tamil, N. Noor, and Z. Razak, "Car park system: A review of smart parking system and its technology," Information Technology Journal, vol. 8, no.2, pp. 101-113, 2009.
- [24] G.R. Marsden, (2006) The evidence base for parking policies - a review. Transport Policy, 13(6), pp.447-457
- [25] L. Mainetti, L. Palano, L. Patrono, M. L. Stefanizzi, R. Vergallo, "Integration of RFID and WSN technologies in a smart parking system", Proc. 22nd Int. Conf. Softw. Telecommun. Comput. Netw. (SoftCOM), 2014.
- [26] Grodi, R. Rawat, D. B. & Rios-Gutierrez, F (2016) "Smart parking: Parking occupancy monitoring and visualization system

