

General Installation Considerations:

There are a number of important factors to consider when evaluating the EcoSieve.

- Power Requirements
- Maintenance
- Operations

These factors can positively impact the economic and operational decision making processes.

Power Requirements

Ideally gravity flow into an EcoSieve will yield the lowest energy cost, however, the EcoSieve has a fixed head loss that may be higher than existing equipment.

Table 1 – Fixed Head Loss of Gravity Flow EcoSieve

EcoSieve Model	Inlet size	Outlet size	Overflow size	Inlet Elev. (C.L.) ¹	Outlet Elev. (C.L.) ¹	Overflow Elev. (C.L.) ¹	Elevation difference In/Out
ES-270	6"	6"	6"	32.00"	14.58"	31.24"	17.42"
ES-940	8"	8"	8"	37.50"	16.03"	37.00"	21.47"
ES-1800	12"	12"	12"	41.50"	19.68"	41.00"	21.82"
ES-3400	16"	16"	16"	49.00"	19.50"	49.00"	29.50"
ES-3600	2x12"	20"	20"	45.13"	20.16"	16.98"	24.97"

If gravity flow is not possible, the EcoSieve can be configured with a smaller inlet nozzle. Pumping power is omitted in these instances because pumping conditions will vary for each application.

The EcoSieve power requirements for each machine are listed in Table 2. Important to note is that power requirements are relatively lower compared to other technologies. This makes EcoSieve an economical choice.

Table 2- Power Requirements

EcoSieve Model	kWh	HP	Estimated Power Usage ²
ES-270	2.09 kWh	2.80 HP	35 kWh/day
ES-940	2.15 kWh	2.88 HP	36 kWh/day
ES-1800	3.58 kWh	4.80 HP	60 kWh/day
ES-3400	4.33 kWh	5.80 HP	72 kWh/day
ES-3600	5.63 kWh	7.55 HP	94 kWh/day

¹ Elevations are from centerlines of pipe to top of base support elevations

² Estimated power consumption based on 24-hr continuous operation and 70% duty cycle (average)



In addition to low energy cost, annual maintenance cost should also be relatively low. Due to EcoSieve's smaller size in relation to other types of equipment, the complete disassembly and reassembly of all components can be completed within a few hours.

Maintenance

The sieve belts will require routine maintenance. The sieve belts wear down after constant movement and therefore will require replacement every 1-3 years. Bearings on the belt conveyor and auger screw will also require inspection and routine replacement every 1-3 years. The dewatering screw press uses nylon brushes that will require routine inspection and replacement.

When the sieve belt is replaced, it is also recommended that all the rubber seals around the conveyor be replaced at the same time. The belt drive and auger drive will require annual inspection. Replacement intervals will vary for different applications, but usually these are expected to last a minimum of 5 years.

Additionally, other systems in the external plumbing will require routine inspection and maintenance, such as the wash pump, wash pump strainer, solenoid valves and hose connections. If all the normal wear parts needed to be replaced during a complete maintenance overhaul, the cost for the parts would typically be less than \$4k and a complete overhaul could easily be performed in less than one day of downtime.

Operations

With regard to the environment in which EcoSieve is being placed, there are elements related to operating the equipment that need to be considered. The following are some important elements.

Overflow Piping Configuration

Another important consideration will be the overflow piping configuration. In the event that the EcoSieve cannot clear the belt fast enough to keep up with the flow, the level in the tank (above the belt) will rise to the point that the influent will overflow in a channel in the housing and out of the housing through the overflow piping. In the ideal arrangement the overflow would be gravity drained back to where it was pumped from and there would be some capacity to handle some overflow in front of the EcoSieve. This arrangement would prevent any by-pass of the filter. In the event that the EcoSieve is fed by gravity, in order to avoid by-pass, there would need to be somewhere for the overflow to go and still be pumped back upstream of the EcoSieve. If this is not feasible, the overflow piping would need to be drained to the effluent piping and every time the filter reached maximum capacity. This would result in a by-pass of the filter.



Wash Water

An important utility consideration besides power will be a source of particle free water to be used as wash water. Table 2 shows the recommended wash water requirements for each model. Although the effluent from the EcoSieve will meet the minimum requirements, it is recommended to use the cleanest wash water available to avoid frequent pump strainer cleanings. Recommended minimum wash water pressures are specified to meet high cleaning pressure recommendations. If, effluents from the EcoSieve are drained directly to the booster pump (for example where an external water source is not available), boosted water pressure for cleaning will be lower because of the low pressure on the booster pump inlet. In light duty services, lower cleaning pressure maybe suitable, but in applications with high solid loadings, lower cleaning pressures may not be suitable. In these circumstances, an additional booster system may be necessary.

When considering the wash system supply water, it is necessary to also consider a hot water system for cleaning Fats, Oils and Greases (FOG) from the belt. In applications where FOG are present, build-up will occur over time which reduces mesh performance. By washing the belt with hot water at approx. 170-180F, FOG will be cleared from the belt. Mitcherson can offer a hot water system or this can be supplied by the customer. Normally, a hot water system is only required on timed intervals determined as necessary for the application and is not constant use.

Table 3 – Wash Water Requirements

EcoSieve Model	Inlet size	Minimum Available Flow Required	Minimum Pressure Required	No. of Belt Wash nozzles	No. of Cage Wash nozzles	Belt Wash @ 100 psi	Cage Wash @ 100 psi
ES-270	3/4"	5 GPM	25 psi	3	4	1.89 GPM	2.52 GPM
ES-940	3/4"	7 GPM	25 psi	6	4	3.78 GPM	2.52 GPM
ES-1800	1"	11 GPM	35 psi	12	4	7.56 GPM	2.52 GPM
ES-3400	1"	13 GPM	40 psi	15	4	9.45 GPM	2.52 GPM
ES-3600	1"	20 GPM	40 psi	24	4	15.12 GPM	2.52 GPM



Closed Compartment Design

Another big advantage the EcoSieve has over conventional technology is the benefit of not having a large exposed body of water. Odors from the EcoSieve are significantly less than open clarifiers or lagoons. Since the EcoSieve housing is a closed compartment, it is only necessary to pull a slight vacuum on the housing to prevent any nuisance odors from escaping. All EcoSieve's come standard with a 3" vent connection on the lid of the housing. This vent can either be capped or a vent line designed to flow 150 SCFM can be attached which either sends vent gases to an odor control system or vents outdoors when the EcoSieve is installed inside closed buildings.

Figure 3 shows a typical basic EcoSieve installation. Basic installation includes piping, foundation, electrical, and washes water. In a basic set-up the solids will be collected either in a container, dumpster or manual bagging system.

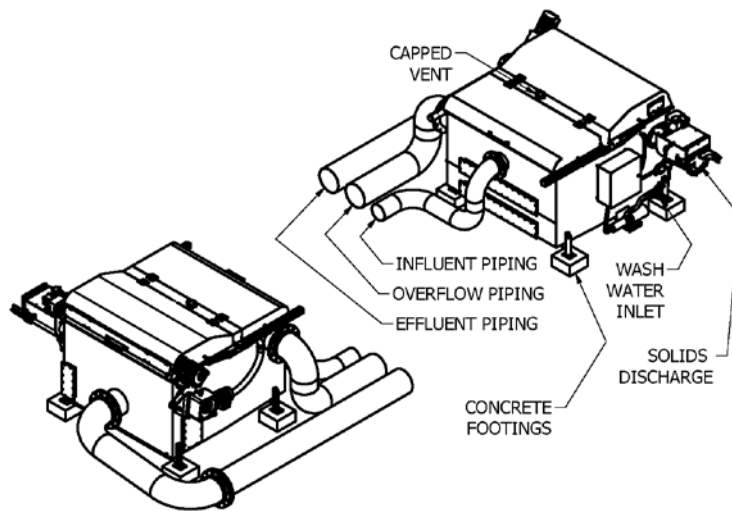

FIGURE 3 - BASIC INSTALLATION

Additional options may be desired by the customer to reduce labor involved in operation and maintenance. Figure 3A shows a suggested arrangement for a dedicated overhead hoist for removing the belt assembly for annual maintenance. This figure also shows a vent duct, which would be a recommended feature if the EcoSieve is located indoors.

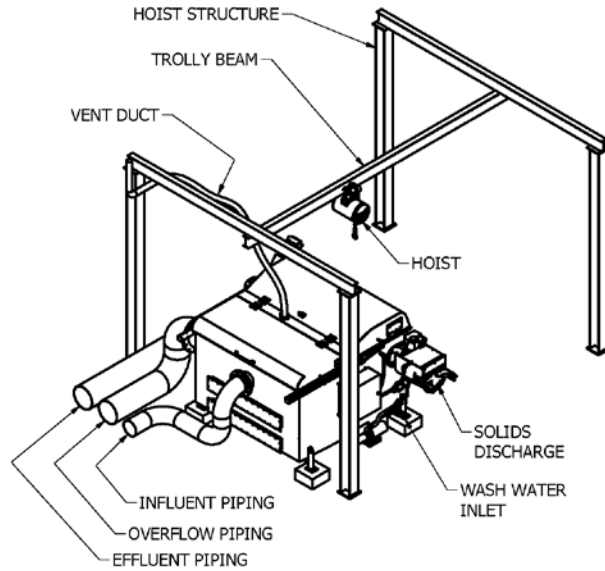

FIGURE 3A - INSTALLATION WITH DEDICATED OVERHEAD HOIST AND VENT DUCT

Figure 3B shows a typical installation with an automated drag chain conveyor that automatically conveys solids to a dumpster that could be located away from the screening installation.

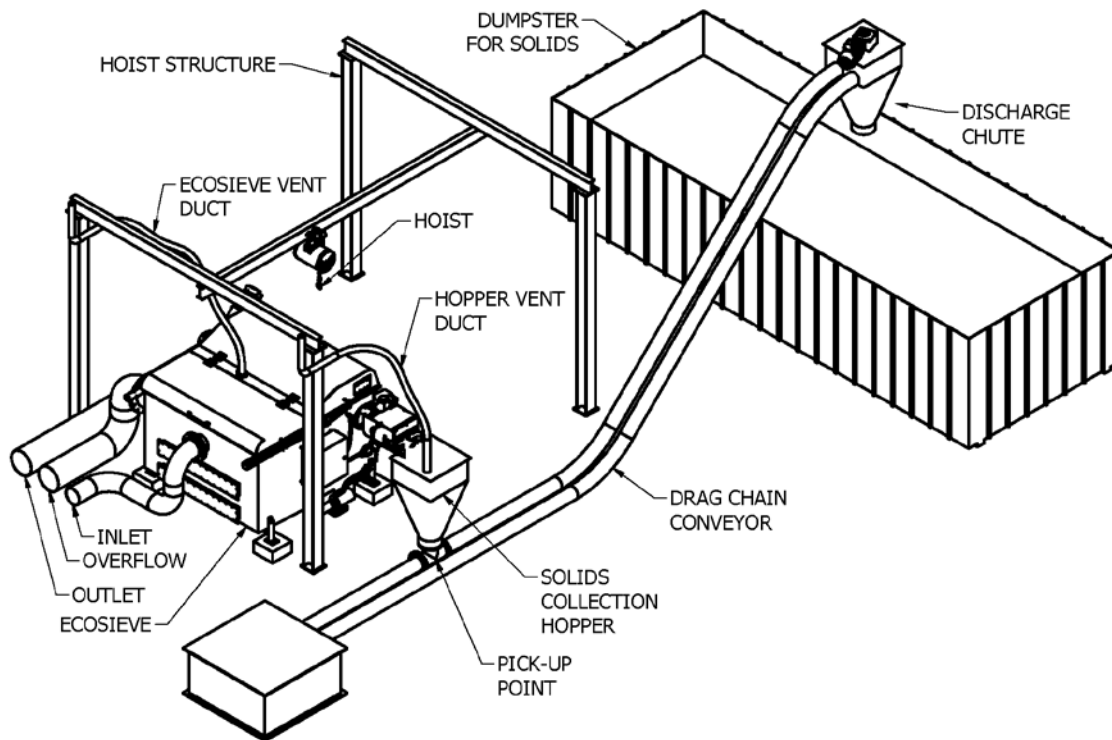

FIGURE 3B - INSTALLATION WITH AUTOMATED SOLIDS COLLECTION

These illustrations are only intended to be examples of how a customer might want to set up a plant. There are countless other ways to achieve an outstanding installation that meets and exceeds the customer's needs.

Feel free to contact our engineering department at (877) 937-0330 ext. 102 for any additional questions you might have.

