

Model **LC-HAI-C**

Filter hood

A

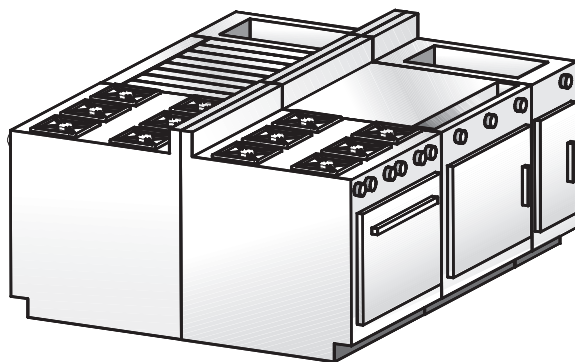
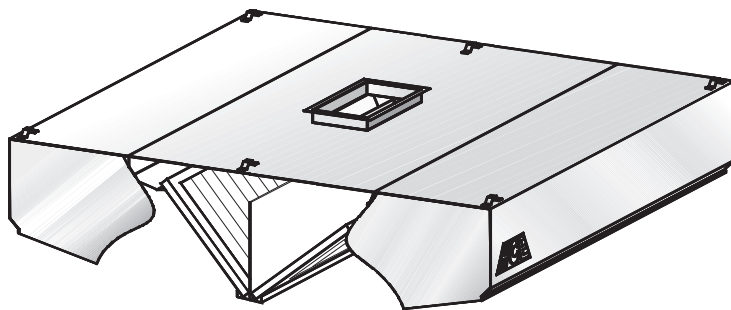

Suggested model

- Restaurant chains
- Island hood
- Low-ceiling kitchens

Description :

HCE central island exhaust hood model LC-HAI-C complete with baffle filters.

Specifications:

- Specially designed for low-ceiling kitchens
- Constructed of sturdy 18-gauge (1.2 mm) stainless steel
- Available in lengths of 3' 0" to 16' 0" (914 mm to 4,877 mm)
- Washable baffle filters
- Easy installation
- Listed 
- Many options available (see reverse)
- Quick delivery

Construction :

Exposed hood surface: type 430 stainless steel (304 optional) with #4 finish (brushed). Non-exposed hood surface: stainless steel with #2B finish. Minimum 18-gauge (1.2 mm) thickness. All visible welded joints are polished to match original finish. To meet NFPA- 96 requirements.

Installation :

Suspension (recommended height)

The hood should be installed 6' 6" (1,981 mm) from the floor.

Semi-combustible materials

A clearance of 3" (76 mm) is required when the hood is in contact with semi-combustible materials. As per NFPA-96 standards, a stainless steel spacer will be required.

Enclosure panels (optional):

The space between the top of the hood and the ceiling may be closed with stainless steel panels in the same finish as the hood.

Electrical:

Junction box and pre-wiring for lighting system may be factory installed if required.



Model **LC-HAI-C**

Length		Exhaust		Collar/opening 14" (355 mm) x _____	
Feet	mm	CFM	L/S	Inches	mm
3'-6"	1068	1820	860	14	356
4'-0"	1220	2080	982	14	356
4'-6"	1372	2340	1105	16	406
5'-0"	1524	2600	1227	18	457
5'-6"	1676	2860	1350	20	508
6'-0"	1828	3120	1473	22	559
6'-6"	1981	3380	1595	24	610
7'-0"	2134	3640	1718	26	660
7'-6"	2286	3900	1840	28	711
8'-0"	2438	4160	1964	30	762
8'-6"	2590	4420	2086	32	812
9'-0"	2743	4680	2208	34	864
9'-6"	2895	4940	2332	(2) 18	(2) 457
10'-0"	3048	5200	2455	(2) 18	(2) 457
10'-6"	3200	5460	2577	(2) 20	(2) 508
11'-0"	3352	5720	2700	(2) 20	(2) 508
11'-6"	3505	5980	2823	(2) 22	(2) 559
12'-0"	3657	6240	2945	(2) 22	(2) 559
12'-6"	3810	6500	3068	(2) 24	(2) 610
13'-0"	3962	6760	3190	(2) 24	(2) 610
13'-6"	4115	7020	3314	(2) 26	(2) 660
14'-0"	4267	7280	3435	(2) 26	(2) 660
14'-6"	4420	7540	3560	(2) 28	(2) 711
15'-0"	4572	7800	3680	(2) 28	(2) 711
15'-6"	4724	8060	3804	(2) 30	(2) 762
16'-0"	4877	8320	3926	(2) 30	(2) 762

* Exhaust for 84" (2,130 mm) V-bank filter central island hood.
Contact us for assistance to determine the appropriate air volume.

Accessories included:

- 1 Exhaust collar (3" high)
- 2 Used grease receptacle
- 3 cULus-listed galvanized steel baffle filters

Optional accessories: (see section "K" for details)

- | | |
|----------|--|
| A | cULus-listed exhaust collar with fire damper |
| B | cULus-listed exhaust collar with balancing damper |
| C | Incandescent lights (Quantity recommended: (1) light per 5 linear feet of hood) |
| D | Wire guard for incandescent lights |
| E | 36" or 48" fluorescent lights
(Quantity recommended: (1) light per 8 linear feet of hood) |
| F | Junction box and pre-wiring for lighting |
| H | Enclosure panels, stainless steel with #4 finish, between hood and ceiling |
| I | PAC-02 programmable control panel |
| J | End skirts should be used to maximize hood performance |
| K | Hanging brackets |
| L | cULus-listed stainless steel baffle filters |

A

Filter hood

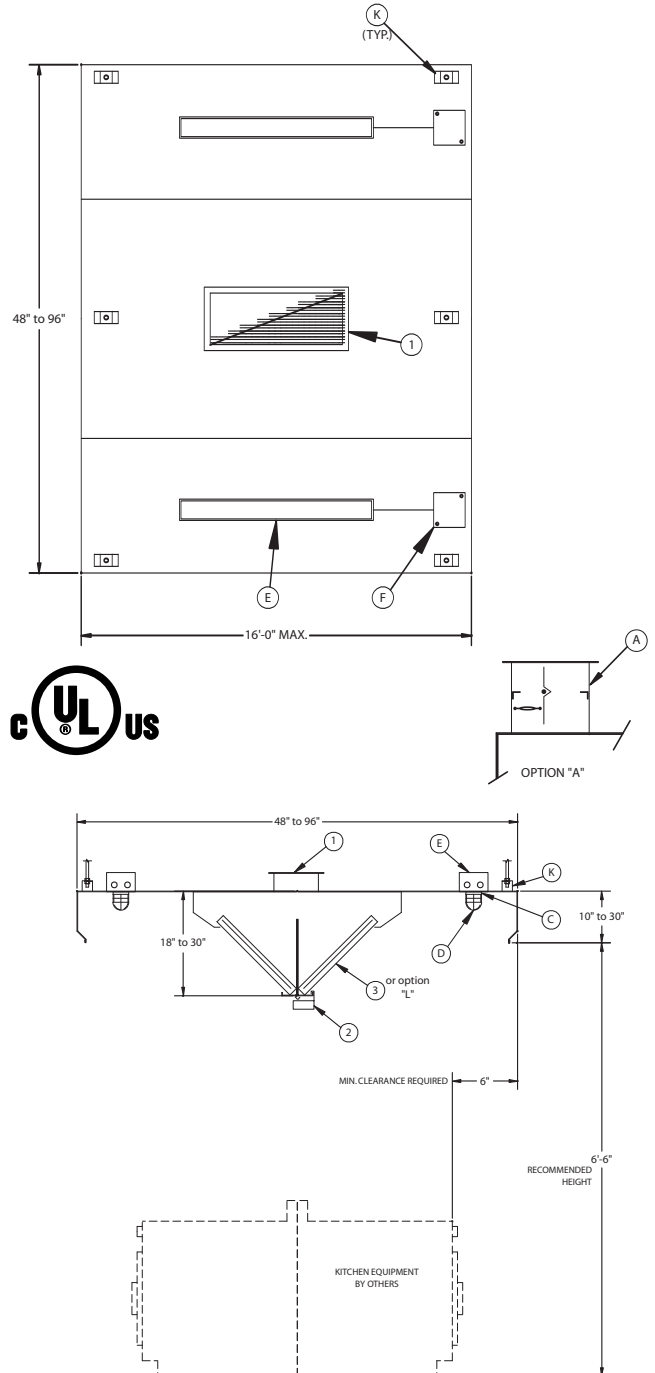

	Exhaust VOLUME (CFM / Lin. Ft.)	Internal pressure loss (IN / H ₂ O)	Exhaust VOLUME (L/S per linear metre)	Internal pressure loss (Pa)
Light cooking	450	0,40	696	100
Medium cooking	520	0,40	800	100
Heavy cooking	700	0,60	1080	150