

# EDGE7

---

Integrated Edge Protection System

## Installation and Inspection Manual



SECTION ONE: INSTALLATION	4	system components
	6	attachment methods overview
	8	important information
	10	<i>attachment method 1</i> - concrete screw ANCHORS
	13	<i>attachment method 2</i> - SINGLE coil insert
	14	<i>attachment method 3</i> - EMBED steel deck attachment
	17	<i>attachment method 4</i> - slab CLAMP (not yet released)
	18	<i>attachment method 5</i> - PARAPET insert
	20	<i>attachment method 6</i> - WALL bracket
	21	tie-off cover plate
	22	component specifications
SECTION TWO: INSPECTION	30	general inspection information
	31	<i>EDGE7 panels</i> inspection form
	33	<i>EDGE7 post</i> inspection form
	34	<i>EDGE7 tie-off anchor point</i> inspection form
	35	<i>EMBED plate</i> inspection form
	36	<i>SINGLE coil insert</i> inspection form
	37	<i>PARAPET insert</i> inspection form
	38	<i>slab CLAMP</i> inspection form (not yet released)
	39	<i>WALL bracket</i> inspection form
	40	<i>REPAIR/DISPOSE</i> form

system components

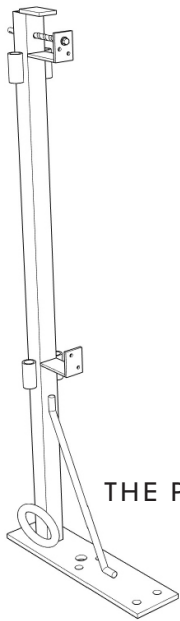

THE POST

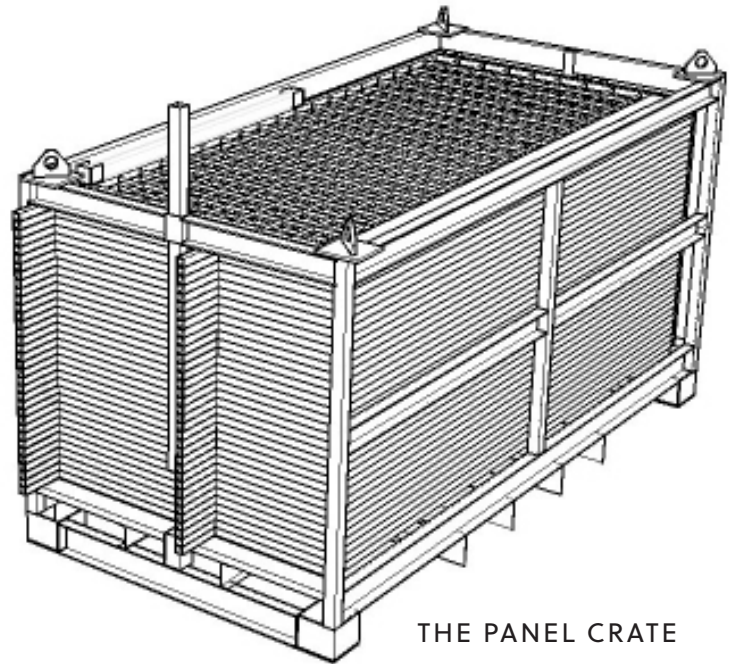

THE PANEL CRATE

THE FIXED PANEL

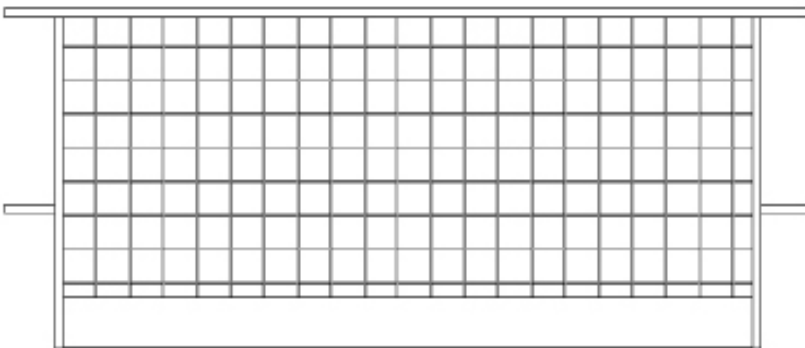

THE ADJUSTABLE PANEL

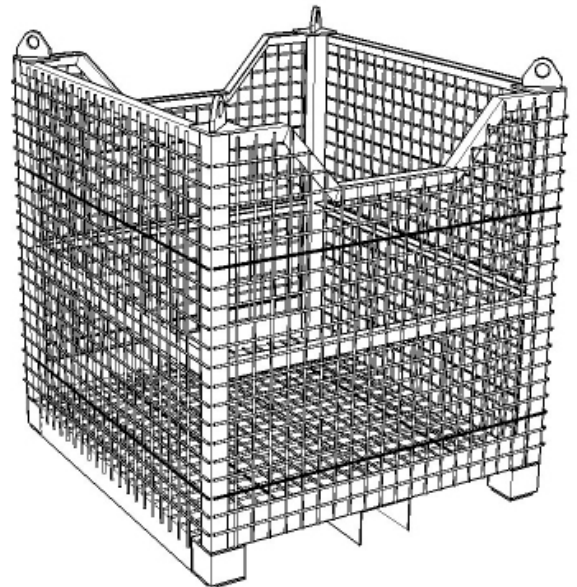
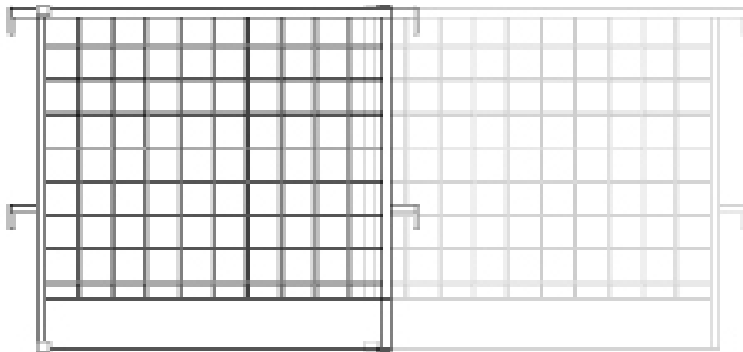

THE POST CRATE

PLEASE SEE PAGES 23-31 FOR DIMENSIONAL DETAILS ON ALL OF THESE COMPONENTS

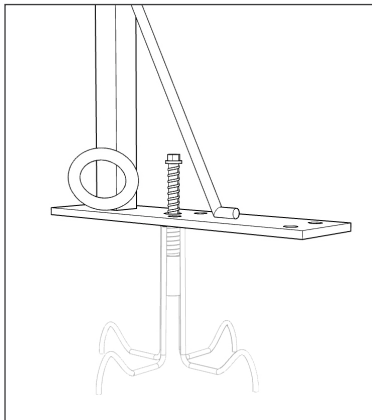

THE SINGLE COIL INSERT

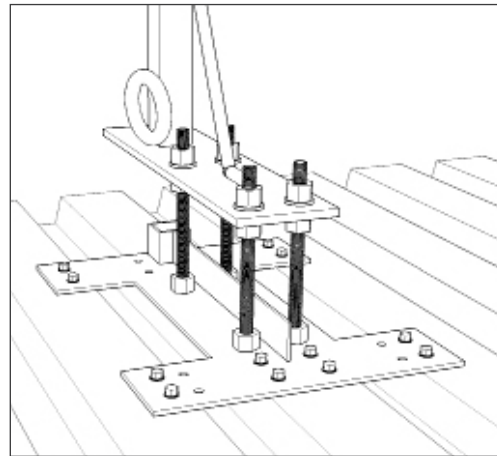

THE EMBED CONNECTOR

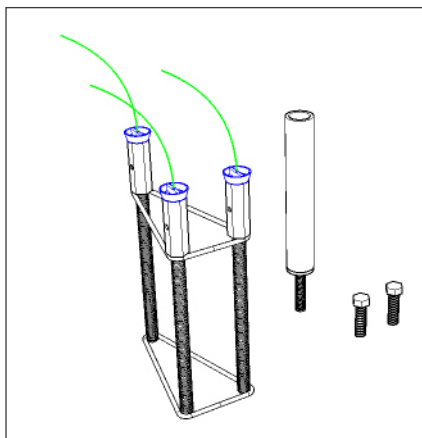

THE PARAPET INSERT

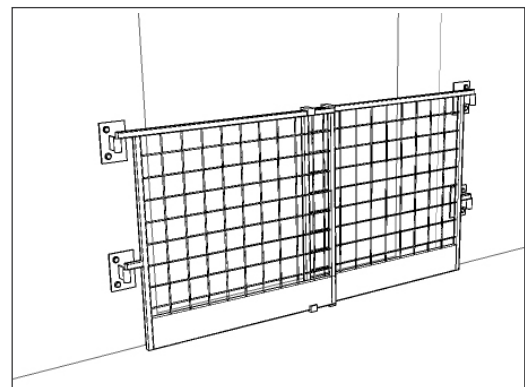

THE WALL BRACKET

## attachment methods

### overview

Various methods of attaching the EDGE7 system to the building structure are available. These methods are outlined here. The choice of method is based primarily on the type of construction. Instructions specific to each method are outlined subsequently. Please contact Highland Safety Systems if you are unsure about which method is best for your specific situation.



Look for this symbol throughout the manual - it indicates instances when the fall arrest anchor **SHALL NOT** be used.

### method 1 concrete screw ANCHORS

This is an excellent and robust method of attaching to poured concrete slabs. It is simple and quick, and the fall arrest tie off anchor can be used as soon as concrete has cured to 20 MPa and the posts are correctly anchored in place. Our new universal POST can be attached using concrete screws in exactly the same way as our first generation post.

This method requires drilling into concrete. Where drilling is not a suitable option, our other attachment methods will serve your needs.

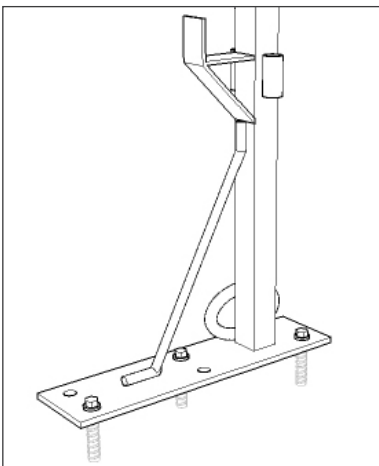

Depending on various factors outlined in the Concrete Anchorage section, 2 or 3 anchor bolts which are 3" - 4" in length are used to secure each post to the concrete.

### method 2 the SINGLE COIL INSERT

The Single Coil Insert is an ideal solution for PT cable. It is cast into the concrete. Once the concrete is cured the plug is pulled out and the post attached with a coil anchor.

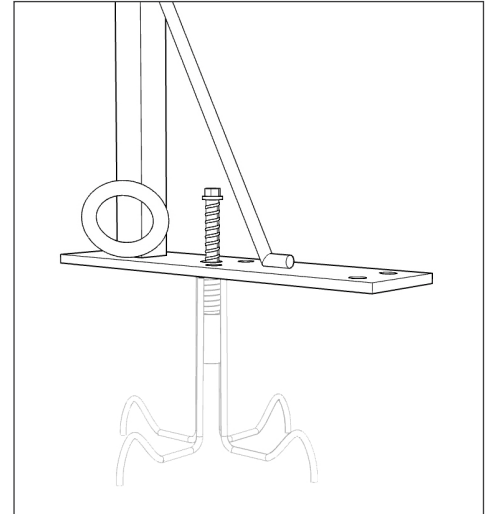

### method 3 the EMBED

The EMBED steel deck attachment plate is designed specifically for composite slab construction. It is suitable for steel deck 22 GA or thicker, and for the various common deck profiles, including 1½", 2" and 3" composite deck.

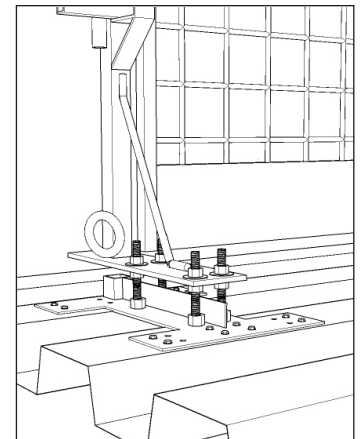

The EMBED plate is attached to the deck with self-drilling screws. The EDGE7 posts are then secured to the plate. The EDGE7 system is in place to protect from this point on. After the concrete is poured and cured to 20 MPa, the tie-off ring is available for use according to the tie-off ring usage instructions. Please see page 13.

### method 4 slab CLAMP

The EDGE7 slab CLAMP is a convenient way to attach to a poured slab without the need for anchors and drilling. The clamp is installed with a torque wrench. Rubber pads are available to prevent the clamp teeth from marking the concrete.

The slab CLAMP has a dedicated post that simply slides into the clamp sleeve. Please see page 18.

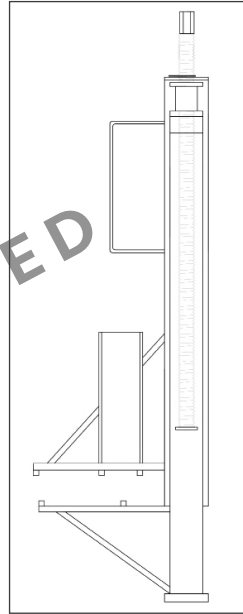

Please note that the slab CLAMP does not come equipped with a tie-off ring. The clamp shall not be used as a tie-off anchor point.

### method 5 parapet INSERT

The parapet INSERT is cast into the concrete parapet as an attachment method for the standard EDGE7 post. The parapet INSERT has threaded plastic plugs that protect the coupling from the concrete while it is being poured. Once the concrete is cured, the post is attached to the parapet with 2 bolts and a threaded pipe stub. Please see page 19.

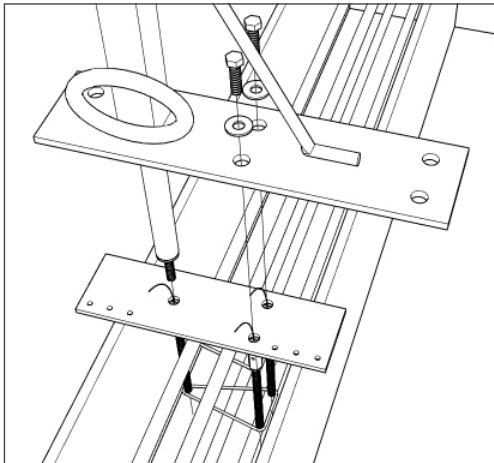

The parapet insert shall not be used as an anchor point. After the post has been attached to the parapet insert, the tie-off ring shall not be used.

### method 6 WALL bracket

The WALL bracket is a great way to provide edge protection at window openings and other open areas. The brackets are bolted to the wall and the EDGE7 panel simply slides into place. Please see page 21.

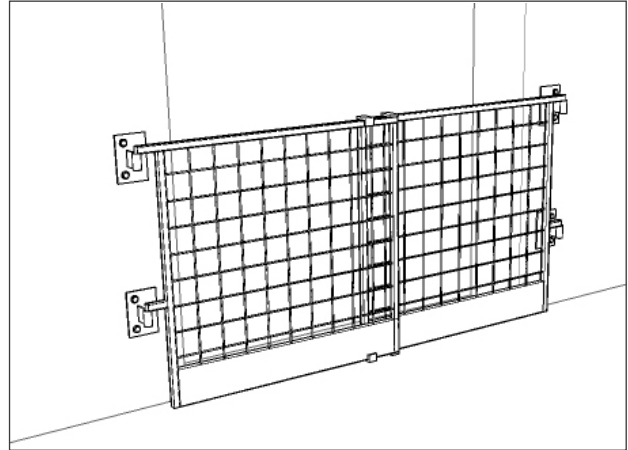

### method 7 WOOD railings

Newer versions of the EDGE7 post include screw/nail holes in the panel support brackets. In the absence of availability of EDGE7 panels, these can be used to affix wood to the posts.

## important information - all attachment methods

### notes

For any questions or clarification regarding this or any other Highland Safety Systems engineered product, please don't hesitate to contact us at [info@highlandssystems.com](mailto:info@highlandssystems.com) or 1.855.591.7272.

The various attachment methods and accessories described in this manual were designed exclusively for attaching the EDGE7 post. No other products or systems shall be used.

The Highland EDGE7 System and all of its components must be installed according to these instructions.

The connection systems have been designed exclusively for use with the EDGE7 system. Not other systems shall be used with them.

The EDGE7 system provides protection in terms of both fall restraint and fall arrest:

#### Fall Restraint

All of the attachment options outlined in this document, when correctly implemented with the EDGE7 system, ensure that load requirements for temporary guardrails are met for all regions in North America.

#### Fall Arrest

Fall arrest anchor load requirements vary widely from region to region. The instructions specific to the regulations in the region in which the EDGE7 system is being installed must be followed. Careful attention must be paid to instances identified in this manual where the fall arrest anchor may not be used.

### the fall arrest anchor

The integrated fall arrest anchor on the EDGE7 post shall only be used after the concrete has properly cured TO 20 MPA (as applicable) and the EDGE7 posts properly installed.

No swing stages, travel restraint or other means of fall arrest/restraint must be attached to the tie-off anchor.

The fall arrest anchor has been engineered for the attachment of a single harness or safety belt. Only one worker may use it at a time.

The fall arrest anchor shall be used exclusively for its design purpose - as a fall arrest anchor point.

The EDGE7 post can be used as a stand-alone fall arrest anchor point, provided that it has been installed according to the directions laid out in this manual.

Users of the EDGE7 system shall be familiar with and follow all specifications and regulations regarding tie-off usage that apply in the location of installation.

In all cases where the fall arrest anchor cannot not be used the tie-off cover plate shall be installed. See page 22.

### warranty

The EDGE7 system and its components are warranted to be free of defaults in material and workmanship for a period of 1 year from the date of shipment. In the event of product damage a comparable replacement will be provided.

### inspection and repair

Forms regarding the inspection and repair of the EDGE7 system and all of its attachment components are available in the Inspection section of this manual.

Components must be inspected prior to installation. A complete inspection must be conducted on at least once per year.

Damaged items must be removed from service and assessed for usability. Repair/remove criteria are outline for each component.

### the job site

All deviations from prescribed arrangements of the EDGE7 system and its components must be designed and reviewed by an individual qualified to practice in the location of installation.

Workers shall be familiar with all applicable site restrictions.

Workers should be familiar with and follow all labour and safety regulations that apply in the location of installation.

Any unsafe or hazardous conditions at the site of the installation should be identified and reported immediately.

### the worker

The EDGE7 system and all its attachment accessories must be installed by a properly trained installer.

Workers installing and/or using the EDGE7 system must first read this manual in its entirety.

Workers must be tied off to a compliant fall arrest anchor or to an existing travel restraint system at all times when installing the EDGE7 system and all of its component, as applicable per health and safety regulations.

The engineered tie-off ring on the properly installed EDGE7 post is the only location on the EDGE7 system that may be used as a tie-off point.

Only one person may be tied off to an EDGE7 tie-off ring at any given time.

Workers shall not lean against the EDGE7 system.

Construction material or other object shall not be leaned or placed on the EDGE7 system.



### the EDGE7 system

All of the EDGE7 system components must be inspected prior to each installation. Those which are damaged or defective must be removed from service. Consult the Inspection section of this manual on page 32 for reference.

Damaged or defective EDGE7 components should only be returned to service once a qualified engineer has inspected them and certified that their capacity to perform to their documented standards has not been compromised in any way.

Handling and installation of the EDGE7 system components requires the use of power tools and lift equipment. The instructions and safety guidelines set out by the manufacturers of the tools and equipment should be followed.

The EDGE7 panels weigh approximately 21 kg/45 lbs (fixed panel) and 27 kg/60 lbs (adjustable panel). Proper lifting techniques should be used, and workers should never lift more than they can safely handle.

Lifting, movement and placement of the EDGE7 system components must be done in a way that does not create a falling object hazard.

The EDGE7 system components must not be modified in any manner.

Objects or items should not be painted, welded or otherwise attached to any component of the EDGE7 system in a way that compromises the integrity of the steel or the strength of its attachment to the structure.

### access to the slab edge

EDGE7 panels can be easily removed for access to the slab edge - no messy ties or wires to deal with.

Workers must be tied off before removing an EDGE7 system panel. Workers must remain tied off until the panel has been replaced.

An area with a removed EDGE7 panel must not be left unattended.

The EDGE7 panel must be properly reinstalled as immediately as possible after removal.

Refer to the regulations specific to the region of installation for complete requirements.

### system positioning

Standards regarding the positioning of the guardrail relative to the slab edge vary from region to region. These standards may include maximum and minimum edge distances. Local regulations must be followed.

Posts must be positioned with the base plate perpendicular to the building edge, with panel brackets and the strength brace facing inwards.

For layout purposes:

- posts supporting EDGE7 fixed panels should be spaced at 7'6" on center
- posts supporting EDGE7 adjustable panels can be spaced 4' to 7' apart
- EDGE7 adjustable panels can pivot to create infinite angles

An edge protection plan should be made. Space is provided in the inspection section of this manual to create a sketch of the plan.

Installed EDGE7 panels must not rest on the post base plate. Doing so will create a gap under the toe board.

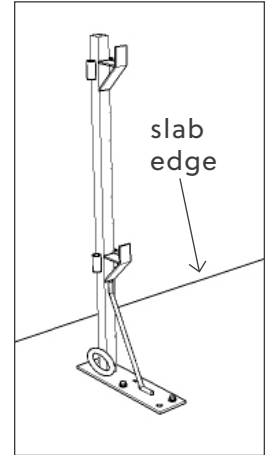

### moving the crates

EDGE7 panels and post have custom crates to allow for easy storage and transport of the EDGE7 system.

Crates can be moved using either a fork lift/pallet jack or the lifting lugs.

When using the lifting lugs, all four lugs must be used.

When using the lifting lugs, local specifications and regulations must be followed.

### using the lifting lugs

Lifting lugs shall be inspected by a qualified P.Eng

Actual inspection requirements such as NDT (Non-Destructive Testing: magnetic particle and liquid penetrant) are up to P.Eng discretion.

Altered or repaired lugs shall be inspected by a qualified P.Eng.

Repairs need to follow established standards.

Visual examination: Inspect lugs prior every lifting. Lugs shall not be used if evidence of: cracks, distortion, bends, fissures, deformations, excessive wear, etc.

When using the lifting lugs, all four lugs must be used.

Make sure slings are properly installed so the angle of action does not exceed 45 degrees against the vertical.

Inspection intervals depends on usage and storage location of units. Conduct inspections minimum twice a year. Log all inspections and keep records of examinations, repairs and inspections.

## attachment method 1: concrete screw ANCHORS

### anchorage details

Post-installed concrete screw anchors must be snug against the post base plate surface but not over-tightened.

System must be anchored to uncracked concrete that has been cured to a strength of at least 20 MPa (3000 psi).

System capacity has been engineered for the use of the following anchors:

- Hilti KWIK HUS concrete anchor
- Powers Wedge-bolt+ anchor
- UCAN Torpedo Bolt

The capacities of the concrete anchors have been engineered in accordance with the requirements of ACI 318-11 and CSA A23.3.

Installation guidelines provided by the manufacturers of these anchors must be followed, including specifications regarding drill bit requirements, embedment depths and wrench torque settings. These specifications are available from the manufacturers' respective websites or from Highland Safety Systems upon request. Use of alternative anchors must be approved by Highland Safety Systems.

The Hilti KWIK HUS anchor is now reusable with the EDGE7 system. Please refer to the guidance provided by Hilti before reusing these anchors.

The anchorage specifications outlined in this section require the posts to be positioned with the outer extremity of the base plate at a minimum of 9" from the edge of the concrete slab. Some local regulations allow the posts to be positioned at other distances from the edge. Please refer to your local regulations for more details.

Anchors longer than those specified must be authorized for use in the slab thickness in question as outlined by the anchor manufacturer.

Anchors provide documented strength for single-use only, unless otherwise specified. Anchors must not be reused unless explicitly permitted by the manufacturer.

The strength of the EDGE7 post anchorage is determined by the thickness of the concrete slab, the distance from the slab edge, and the arrangement and size of anchors used. Anchorage options are provided for all existing North American load requirements based on these factors. Please read the options carefully to determine which anchorage option(s) applies to your particular situation.

### anchorage layout options

The EDGE7 post plate has 5 holes to accommodate concrete anchors. Not all of the holes need to be used. Page 11 contains a diagram showing various combinations of anchor layouts. Charts are provided that indicate the brand, size and layout of anchors suitable for 2 different fall arrest tie off load capacity regulations - 8 kN and 22 kN

**!** Fall arrest load requirements vary from region to region. Anchor layout instructions corresponding to the load requirements in the location of the installation must be properly identified and followed. Please contact Highland Safety Systems if assistance is required.

### approved anchors

ANCHOR NAME	SIZE	PART NUMBER
Hilti KWIK HUS Carbon Steel Screw Anchor	½" x 3"	3469904
Hilti KWIK HUS Carbon Steel Screw Anchor	½" x 3½"	3469905
Powers Wedge-Bolt+ Screw Anchor	½" x 3"	7244SD
Powers Wedge-Bolt+ Screw Anchor	½" x 4"	7246SD
UCAN Torpedo Bolt	½" x 4"	UTB124

### anchor layout options

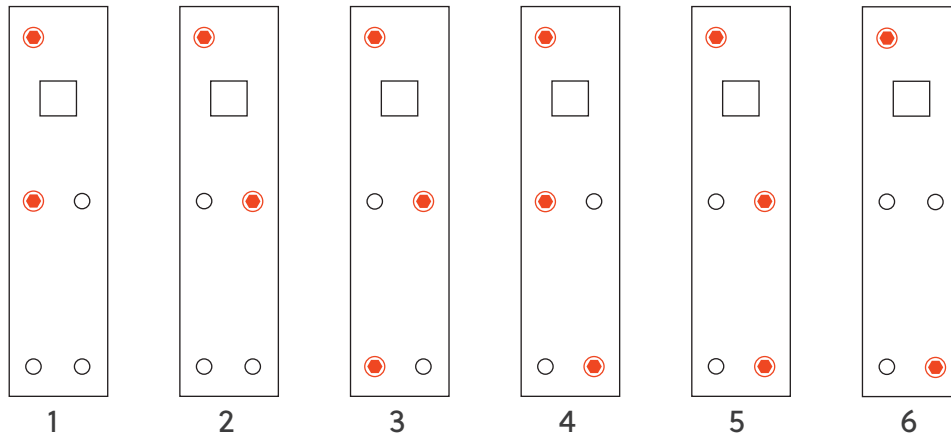

In the subsequent charts specific anchors are identified by the letters 'A' and 'B' and are outlined below. Please refer to page 7 for specific part numbers.

**A** - Hilti KWIK HUS ½" x 3"  
Powers Wedge-Bolt+ ½" x 3"

**B** - Hilti KWIK HUS ½" x 3½"  
Powers Wedge-Bolt+ ½" x 4"  
UCAN Torpedo Bolt ½" x 4"

### fall arrest load requirements up to 8 kN

For regulations requiring fall arrest anchor load capacities to be at least 8 kN (1800 lbf.), the following chart outlines the allowable anchorage layouts and anchor brands/sizes. These options are valid for any slabs 4" or thicker.

	LAYOUT 1	LAYOUT 2	LAYOUT 3	LAYOUT 4	LAYOUT 5	LAYOUT 6
minimum slab thickness	4" SLAB	A	A	A	A	A

### fall arrest load requirements up to 22 kN

For regulations requiring fall arrest anchor load capacities to be at least 22 kN (5000 lbf.), the following chart outlines the allowable anchorage layouts and anchor brands/sizes based on slab thickness.

	LAYOUT 1	LAYOUT 2	LAYOUT 3	LAYOUT 4	LAYOUT 5	LAYOUT 6
minimum slab thickness	4" SLAB	<del>X</del>	<del>X</del>	A	A	A
	6" SLAB	B	B	A	A	A
	10" SLAB	B	B	A	A	A

## attachment method 1: concrete screw ANCHORS

### step by step



**DO NOT USE THE TIE-OFF ANCHOR POINT UNTIL THE CONCRETE HAS PROPERLY CURED (AS APPLICABLE) AND THE POST HAS BEEN FULLY ANCHORED TO THE CONCRETE.**

1. Determine the fall arrest load requirement for the region in which the EDGE7 system is going to be installed.
2. Choose the layout and anchor brand/size based on the tables on page 11.
3. Plan layout of guardrail posts. For ease of installation, snap a chalk line across the back of the first installed post parallel to the slab edge, and install the subsequent posts square to this line.
4. Scan the slab surface to avoid steel reinforcement. Following manufacturer's directions, drill required holes in the concrete. Remove dust and debris from drilled holes using hand pump, compressed air or vacuum.
5. Anchor post using the anchor length and layout options outlined on page 8. Anchors must be installed with a powered impact wrench or torque wrench.



**THE FALL ARREST RING ON THIS POST CAN NOW BE USED AS A FULLY COMPLIANT TIE-OFF ANCHOR POINT.**

6. Repeat steps 1-6 with next post, spaced at a maximum of 7'6".
7. Hang the EDGE7 panels.

**HANGING THE FIXED:**  
simply hang them on the support brackets (figure 1)

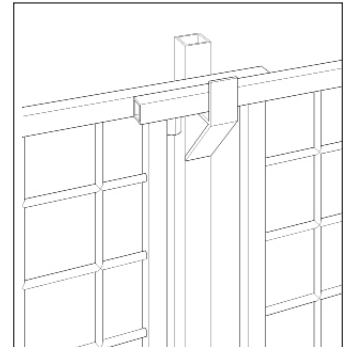

figure 1

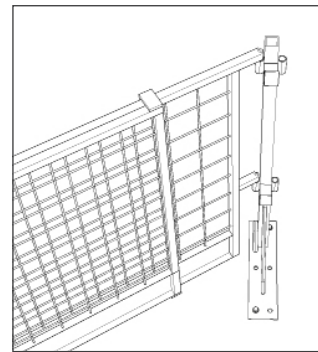

figure 2

**HANGING THE ADJUSTABLE:**  
if the adjustable is being used to angle the guardrail, they are dropped into the round sleeves (figure 2). Otherwise they hang on the post support brackets (figure 3).

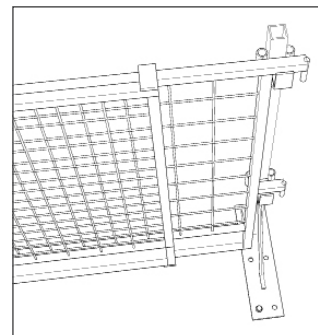
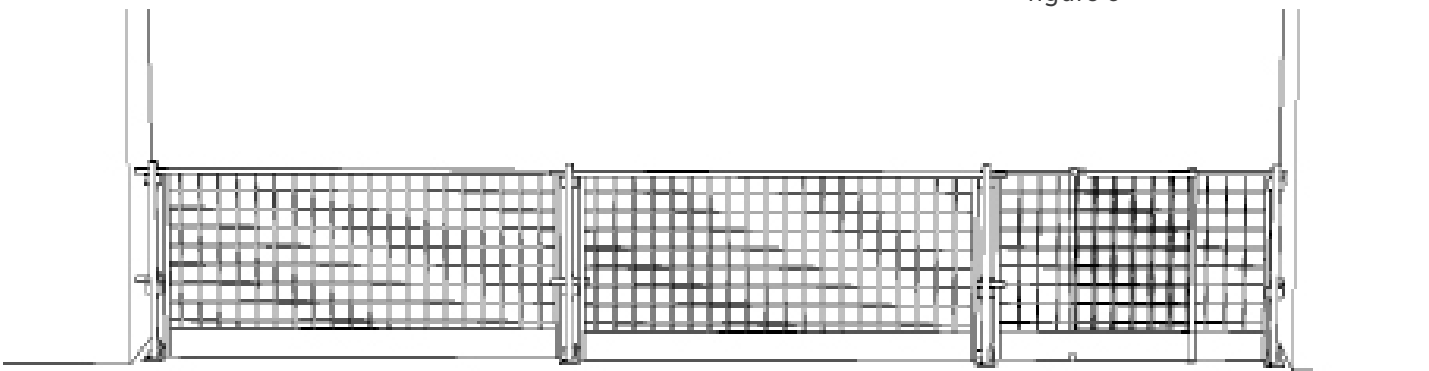
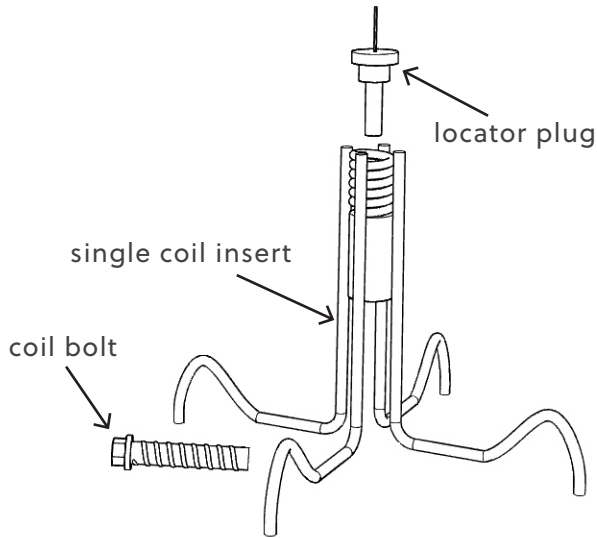

figure 3



### SINGLE coil insert components



### anchorage details

Approved single coil inserts include:  
- Dayton Superior T6A Brace Anchor

The use of other coil inserts must be approved by Highland Safety Systems.

Slab depths compatible with the single embedded coil insert are: 7", 8 and 10".

The minimum edge distance is 15" with a 3/8" setback. The coil bolt has a minimum embedment of 3".

The capacity of the single coil insert has been engineered in accordance with the requirements of ACI 318. Installation guidelines provided by the manufacturers of these cast-in inserts must be followed. These specifications are available from the manufacturers' respective websites or from Highland Safety Systems upon request.

The specifications outlined in this section require the posts to be positioned with the outer extremity of the base plate at a minimum of 15" from the edge of the concrete slab. Some local regulations allow the posts to be positioned at other distances from the edge. Please refer to your local regulations for more details.

Coil bolts provide documented strength for single-use only, unless otherwise specified. Coil bolts must not be reused unless explicitly permitted by the manufacturer and bolts condition has been properly evaluated.

### step by step



**DO NOT USE THE TIE-OFF ANCHOR POINT UNTIL THE CONCRETE HAS PROPERLY CURED (AS APPLICABLE) AND THE POST HAS BEEN FULLY ANCHORED TO THE CONCRETE.**

1. Plan layout of guardrail posts. For ease of installation, snap a chalk line across the back of the first installed post parallel to the slab edge, and install the subsequent posts square to this line.
2. Choose the size of your cast in anchor(coil insert) based on your slab depth – once installed, the top of the plug should be level with the eventual surface of the concrete
3. Properly secure the cast-in coil insert legs to the formwork, ensuring that they remain upright and vertical. Make sure the locator plug is installed.
4. Pour the concrete, ensuring that the cast-in coil inserts remain vertical and upright.
5. Once the concrete has cured, locate the cast-in anchors using the protruding plastic stub on the plastic plugs. Remove the plugs.
6. Secure the Universal Post to the concrete by inserting a coil bolt through the large hole in the post base plate and threading it securely into the embedded anchor.



**THE FALL ARREST RING ON THIS POST CAN NOW BE USED AS A FULLY COMPLIANT TIE-OFF ANCHOR POINT.**

7. Repeat steps 5 and 6 with subsequent posts, spacing them at a maximum of 7'6" OC.
8. Hang the Edge7 panels

## attachment method 3: EMBED steel deck attachment

### EMBED components

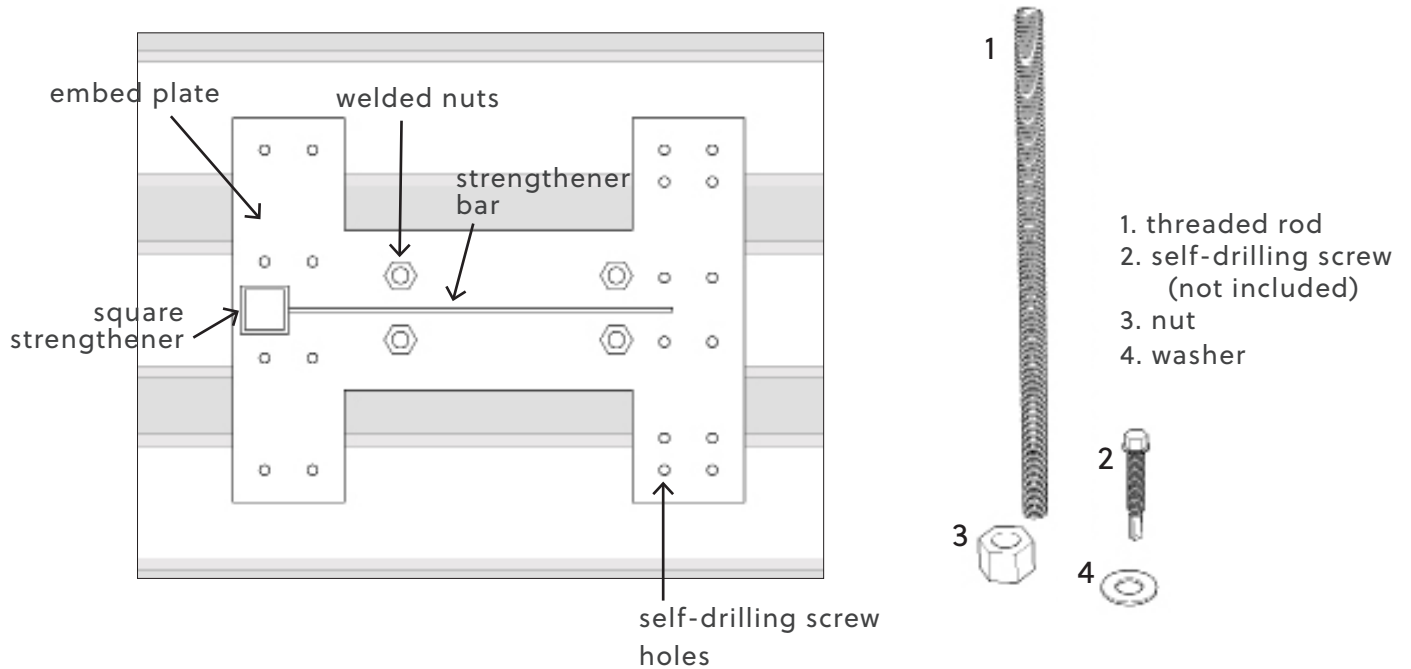

### EMBED positioning

The EMBED plate must be positioned so that the EDGE7 post will be perpendicular to the building edge, with panel brackets facing inwards. The back (the short side with the square strengthener) of the EMBED plate will be parallel and closest to the edge.

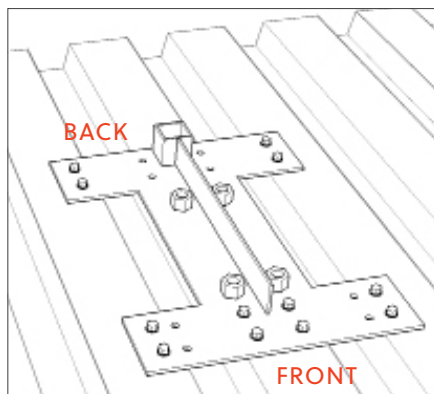

guardrail perpendicular to flutes

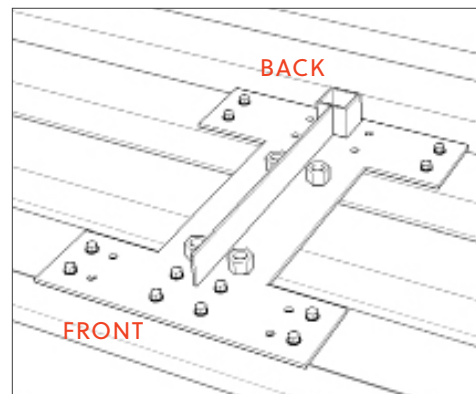

guardrail parallel to flutes

The EMBED plate must be positioned so that at least 4 of the back and 8 of the front screw holes are in contact with the top of a deck flute. Depending on the deck profile, this may require the plates to be centered on the flute tops or troughs.

### anchorage

The EMBED attachment system has been engineered for use with specific self-drilling screws. These screws are not provided and must be ordered from the respective suppliers. Engineering approval is in place for the following self-drilling screws:

Hilti S-MD ¼ -14x1 HWH3 -  
part number 2099049

Installation guidance provided by the manufacturers of these screws must be followed. Substitute screws must be ¼" ⌀ self-drilling screws with a minimum  $F_u = 45\text{KSI}$  (210 Mpa) and a minimum pullout capacity of 0.635 kN (143 LBS) in 22 GA galvanized steel deck and must be approved by Highland Safety Systems.

To prevent stripping of the steel deck, screws must not be overtightened.

### step by step



**DO NOT USE THE TIE-OFF ANCHOR POINT UNTIL THE CONCRETE HAS CURED TO A MINIMUM OF 20 MPa (3000 psi)**

\* Don't forget to order a sufficient quantity of self-drilling screws!

1. Determine the layout of the EMBED plates according to the information provided in 'system positioning' on page 9.
2. Attach the embed plate to the steel deck using a minimum of 12 self-drilling screws. At least 4 screws must be used on the back and at least 8 screws must be used on the front. Screws must be used in holes that are directly in contact with the steel deck.

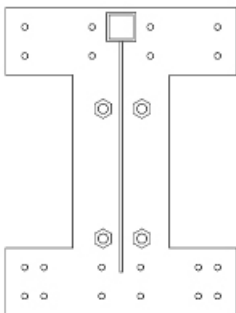

Use at least 4 of the 8 back holes - minimum 2 on each side of the square strengthener

Use at least 8 of the 12 front holes - minimum 4 on each side of the strengthener bar

### 3. ADD RODS, NUTS AND WASHERS

Thread the 4 threaded rods into the nuts that are welded onto the plate and tighten well. Thread 4 of the loose nuts onto the 4 threaded rods. The top of the nuts must create a level surface for the post plate to rest upon. Add 4 of the washers on top of the threaded nuts. The threaded rod must extend at least 1 ½" above the washer.

The top of the washers is the height at which the bottom of the post plate will rest.

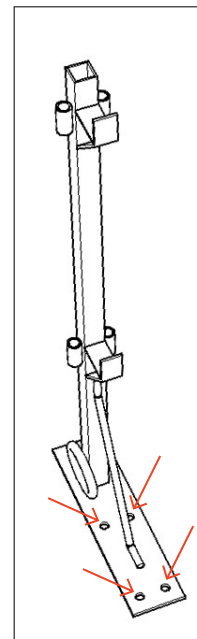
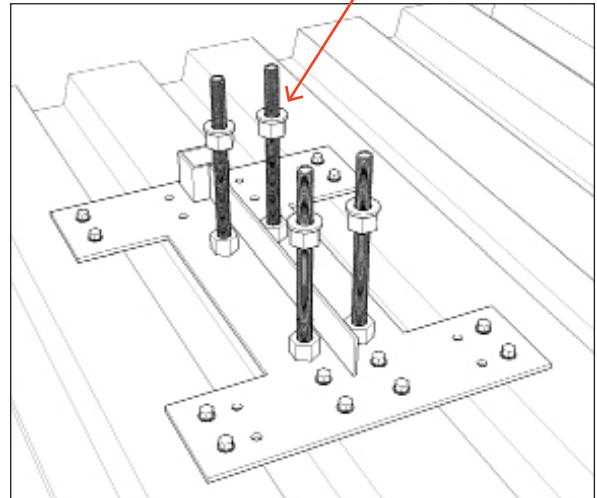

The 4 holes at the front of the EDGE7 post plate will fit over the 4 threaded rods.

## attachment method 3: EMBED steel deck attachment

### step by step continued

#### 4. PLACE THE POST

Lower the EDGE7 post until it comes to rest on the 4 washers. Secure with the remaining nuts and washers. Tighten well.

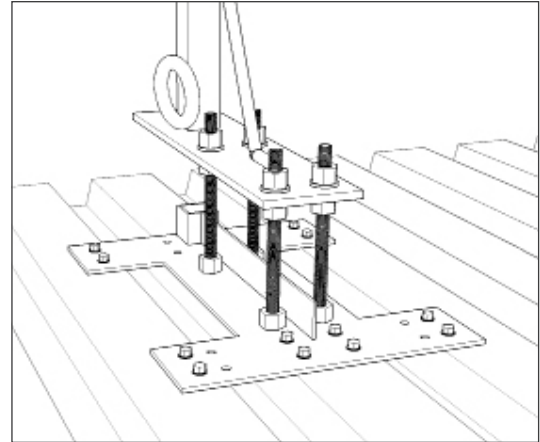

#### 5. HANG THE PANELS

Once all the necessary EMBED plates and EDGE7 posts are properly installed, simply hang the EDGE7 panels on the posts. Please refer to page 9 for tips on hanging the panels.



**REMEMBER: THE TIE OFF RING MUST NOT BE USED AT THIS POINT. IT MUST ONLY BE USED ONCE THE CONCRETE HAS CURED TO A MINIMUM OF 20 MPa (3000 psi)**

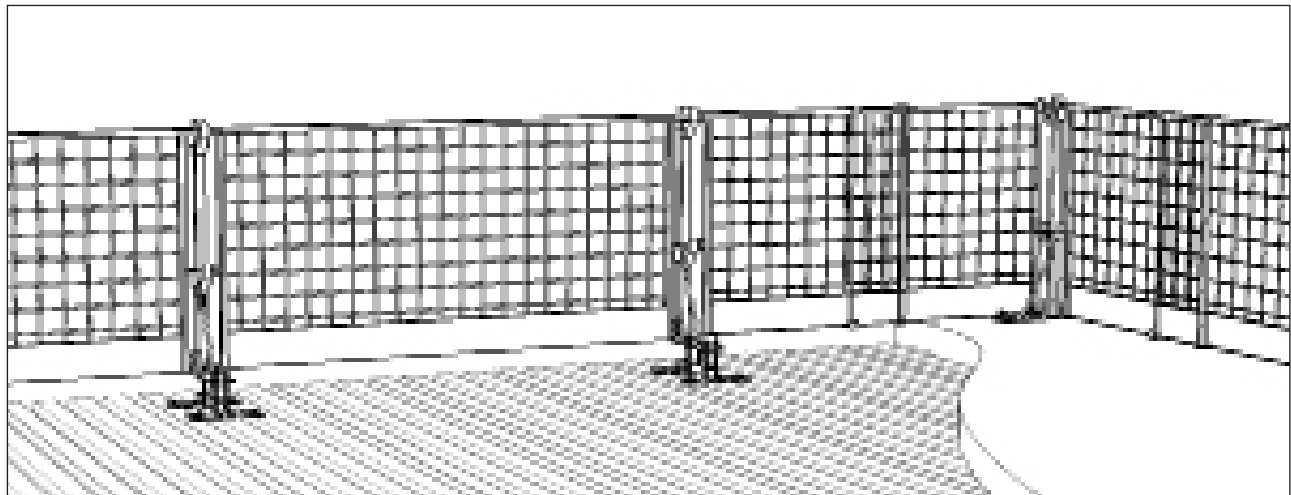

**ONCE THE CONCRETE HAS CURED TO A MINIMUM OF 20 MPa (3000 psi) THE FALL ARREST RING ON THIS POST CAN BE USED AS A FULLY COMPLIANT TIE-OFF ANCHOR POINT.**



### slab CLAMP components

### attachment to slab

The slab CLAMP must be firmly attached to the slab, and must be installed at a 90° angle to the slab.

Use a minimum 250 lb torque wrench to tighten the nut at the top of the CLAMP.

The slab the CLAMP is being attached to shall have been cured for at least 7 days or to 20 MPa.

The CLAMP must be installed on a clean, flush surface.

The CLAMP can be used on slabs from 4 - 10" thickness.

### step by step

**⊗!** DO NOT USE THE SLAB CLAMP OR CLAMP POST AS A TIE OFF POINT.

1. Tie the clamp off to an approved fall arrest anchor point.
2. Open the clamp a few inches wider than the depth of the slab it will be attached to.
3. Position the clamp on the slab edge.
4. Tighten the nut at the top of the clamp with a minimum 250 lb torque wrench.
5. The CLAMP can now have its tie-off removed.
6. Slide the clamp post into the clamp post sleeve.
7. Hang the EDGE 7 panels.

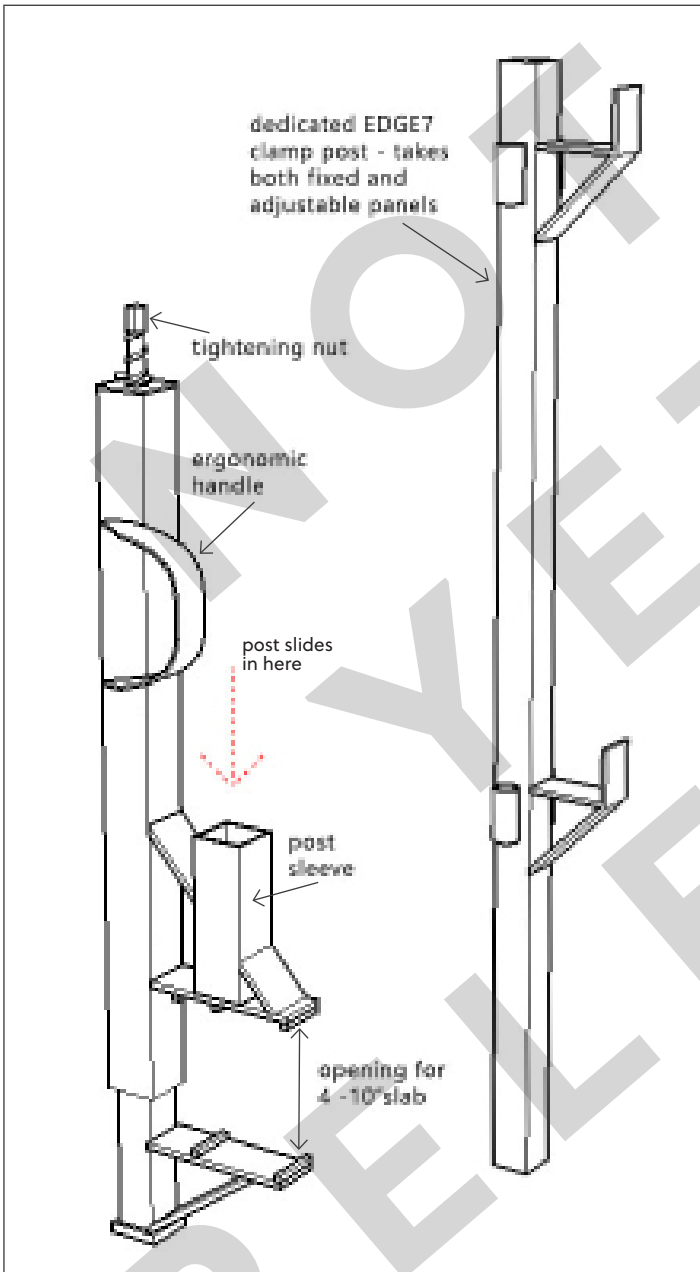

## attachment method 5: PARAPET insert

### PARAPET insert components

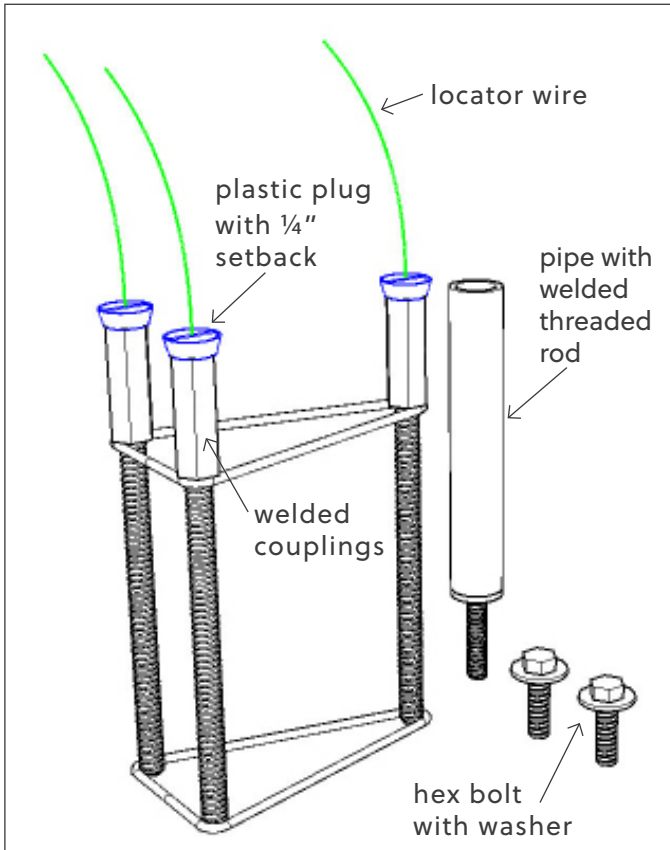

### PARAPET insert positioning

The PARAPET insert attachment accessory must be positioned so that the EDGE7 post will be perpendicular to the building edge, with panel brackets facing inwards.

The short side of the PARAPET insert with the 2 threaded rods will be on the interior side of the parapet.

### attachment to formwork

Use the template shown on page 30 to ensure that the PARAPET insert is level.

The PARAPET insert must be firmly attached to the rebar with tie wire.

Immediately before the pour, each PARAPET insert should be checked to ensure that it is secure.

### attaching the post

Both middle holes must be used to attach the EDGE7 post to the PARAPET insert.

Bolts must be thoroughly tightened.

Bolts shall be 3/8" diameter x 1 1/4" A307

Washers shall be 7/16" ID and 1" OD ASTM F844

### using the tie-off

The tie-off on the EDGE7 post shall not be used except where the parapet is greater than 8" wide and the cast-in INSERT has been used, and the concrete has cured to minimum of 20 MPa (3000 psi)



**DO NOT USE THE PARAPET INSERT AS A TIE-OFF POINT**

### step by step



THE TIE OFF ANCHOR POINT ON THE EDGE7 POST MAY NOT BE USED WITH THE PARAPET INSERT. THE TIE-OFF RING SHALL BE COVERED WITH THE TIE-OFF COVER PLATE TO PREVENT USE. SEE PAGE 21

1. Set the top of the PARAPET insert couplings 1/4" below concrete surface. The plastic plugs should be level with the top of the concrete.
2. Immediately prior to pouring the concrete, inspect each unit to ensure it is still securely fastened and plumb.
3. After the pour, locate the plugs using the locator wires and remove them.
4. Fully thread the hollow pipe into the outside coupling. Tighten.
5. Place the EDGE7 post so that the hollow pipe fits into the main vertical member of the post.
6. Finish fastening the EDGE7 post to the structure with the hex bolts and washers.
7. Hang the EDGE7 panels.

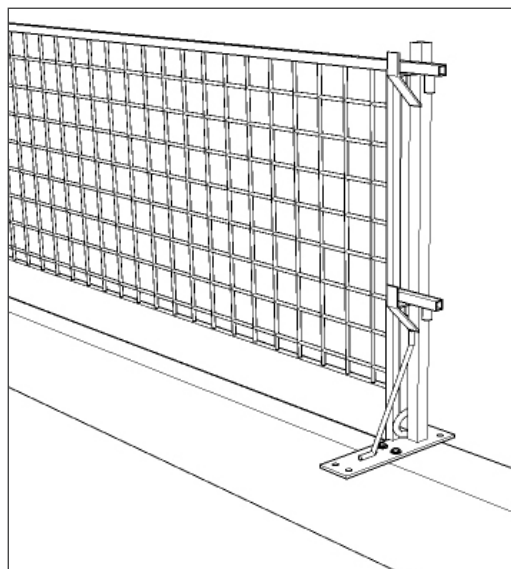
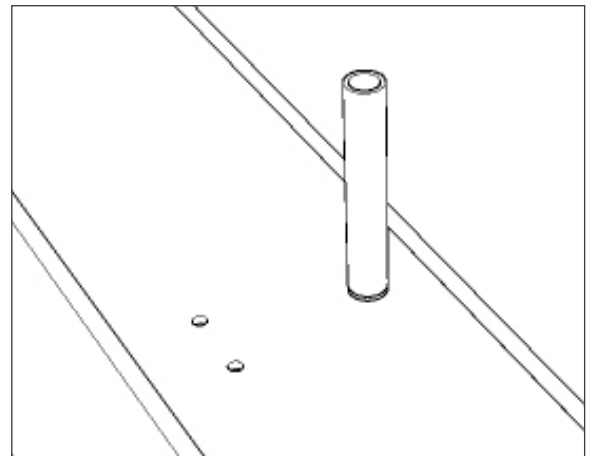
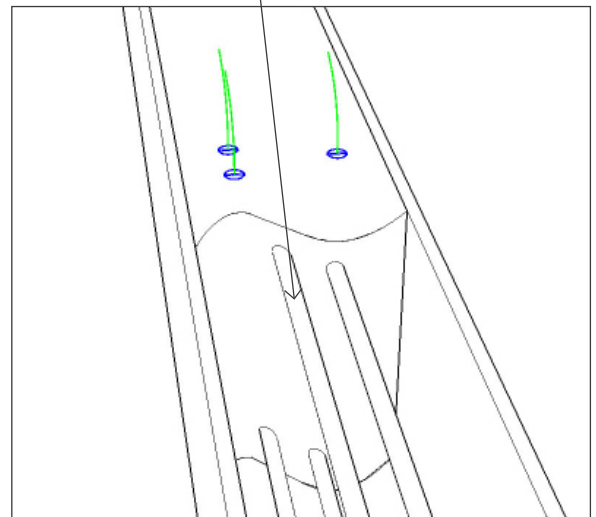
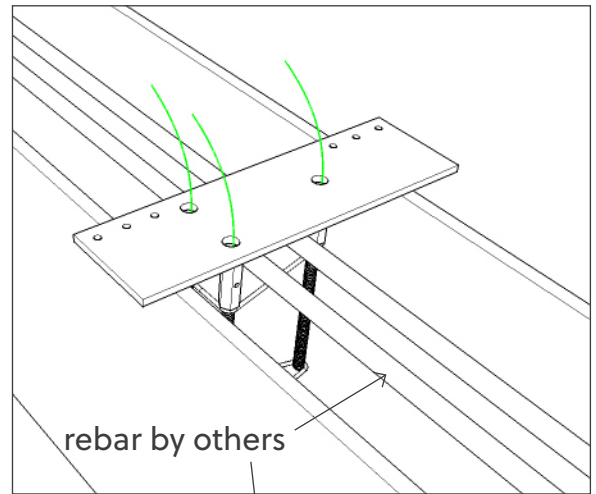

## attachment method 6: WALL bracket

### WALL bracket components

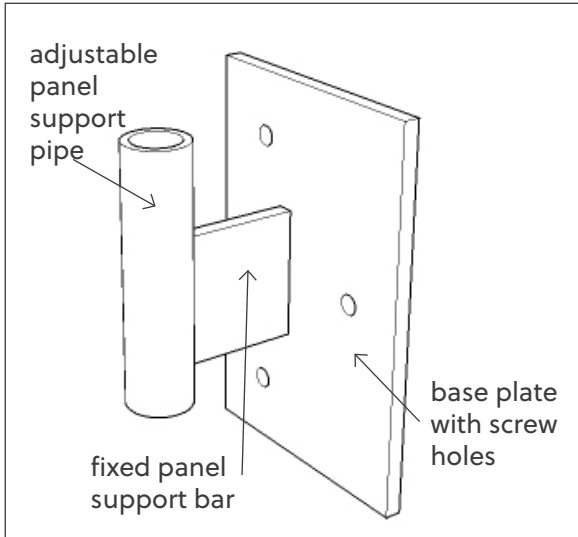

FIGURE 1

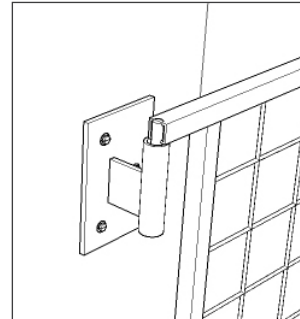
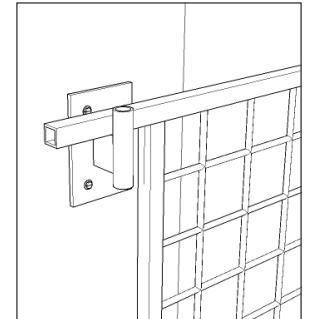

FIGURE 2



### step by step

1. Determine the required placement of the 4 wall bracket for each panel. Use the panel dimensions on page 23 and the WALL bracket dimensions on page 31.
2. Attach the 4 WALL bracket in their place using all 3 anchor holes.
3. Hang the panels.

### WALL bracket notes

Adjustable panels are attached to the WALL bracket by sliding the pin into the panel support pipe (Figure 1).

Fixed panels are hung on the support bar (Figure 2).

The WALL bracket must be attached to the wall with 1/4" diameter Blue Climaseal Tapcon anchors or approved equivalent. All 3 holes must be used.

The WALL bracket may be attached to the inside of the wall (Figure 3, 4) or the inside of the opening (Figure 5).

The WALL bracket may be placed at floor height, in which case there should be a maximum of 1/4" gap below the toe board, or at an elevated height, in which case the bottom of the opening should be complete covered by the panel.

Scan the wall for conduit/reinforcement before installation.

WALL bracket to be installed on concrete surface only.

WALL bracket to be installed on an even surface.

The bracket must be placed a minimum of 1/4" away from any openings or corners.



**DO NOT USE THE WALL BRACKET AS A TIE OFF POINT.**

FIGURE 3

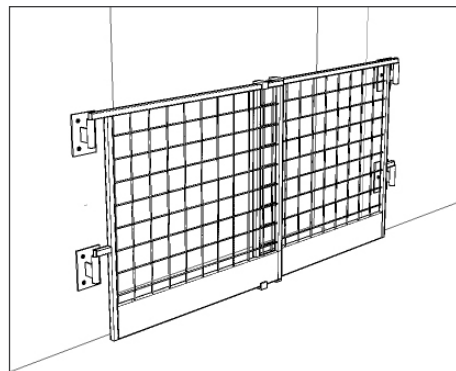

FIGURE 4

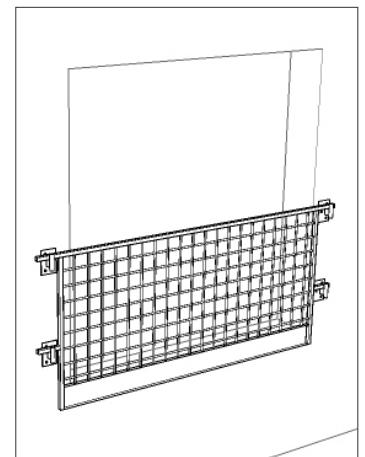
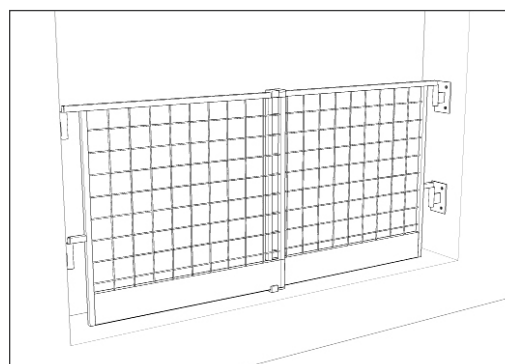
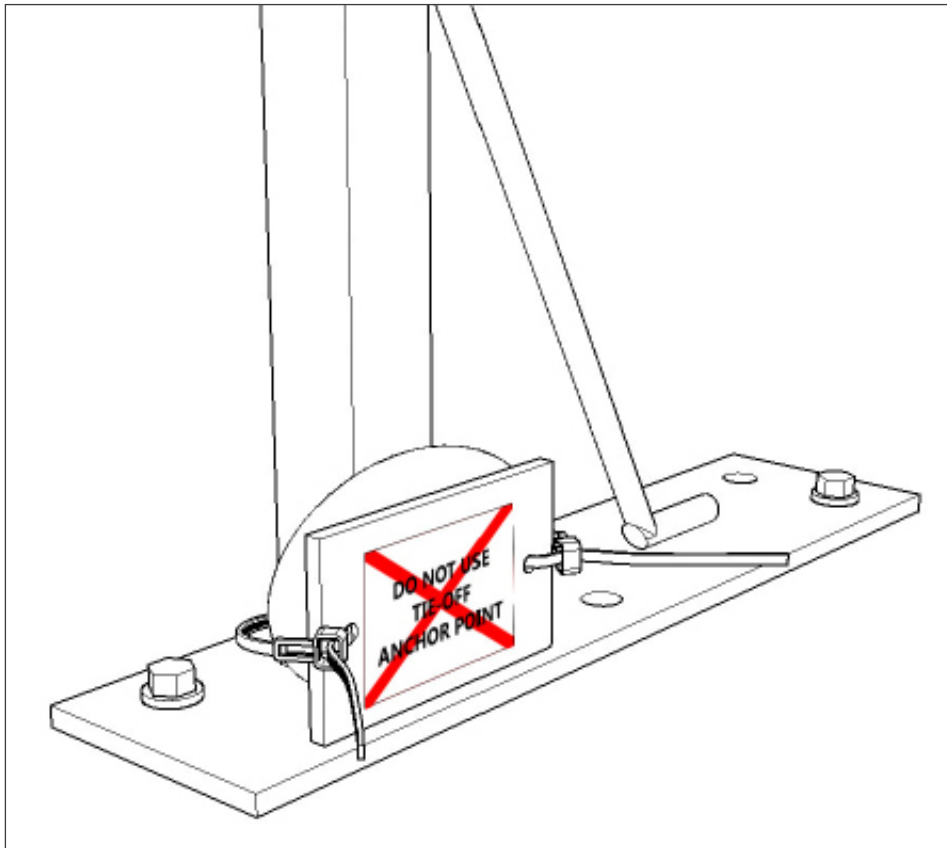
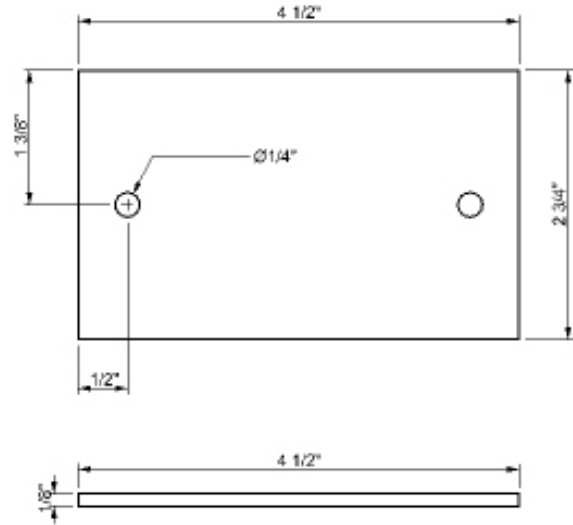

FIGURE 5



The tie-off COVER plate shall be used in all circumstances outlined in this manual when the tie-off anchor point may not be used. Attach the plate to the anchor point with the text facing outwards as shown. Use zip ties or tie wire to fasten.



adjustable panel details

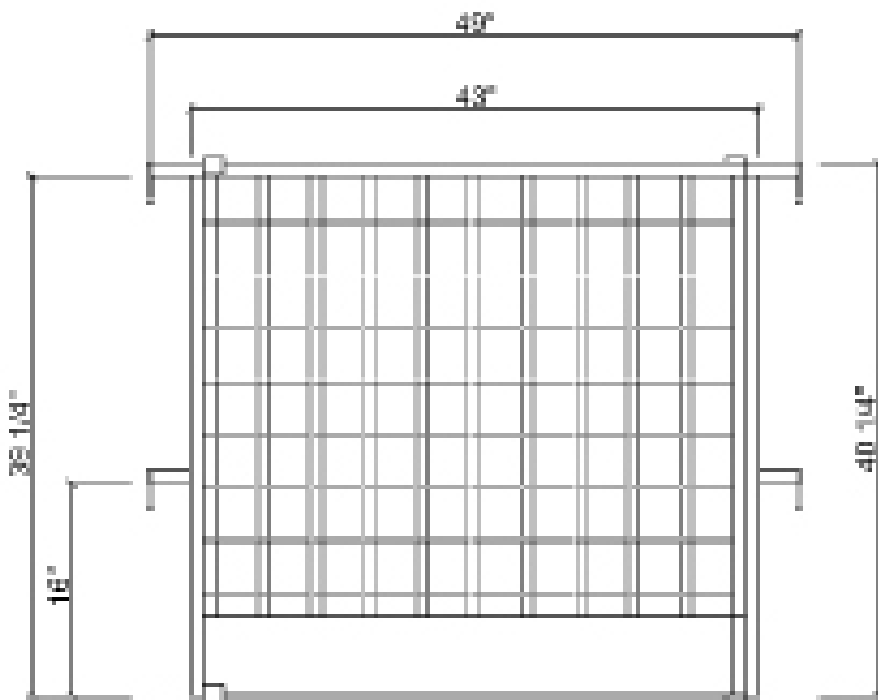
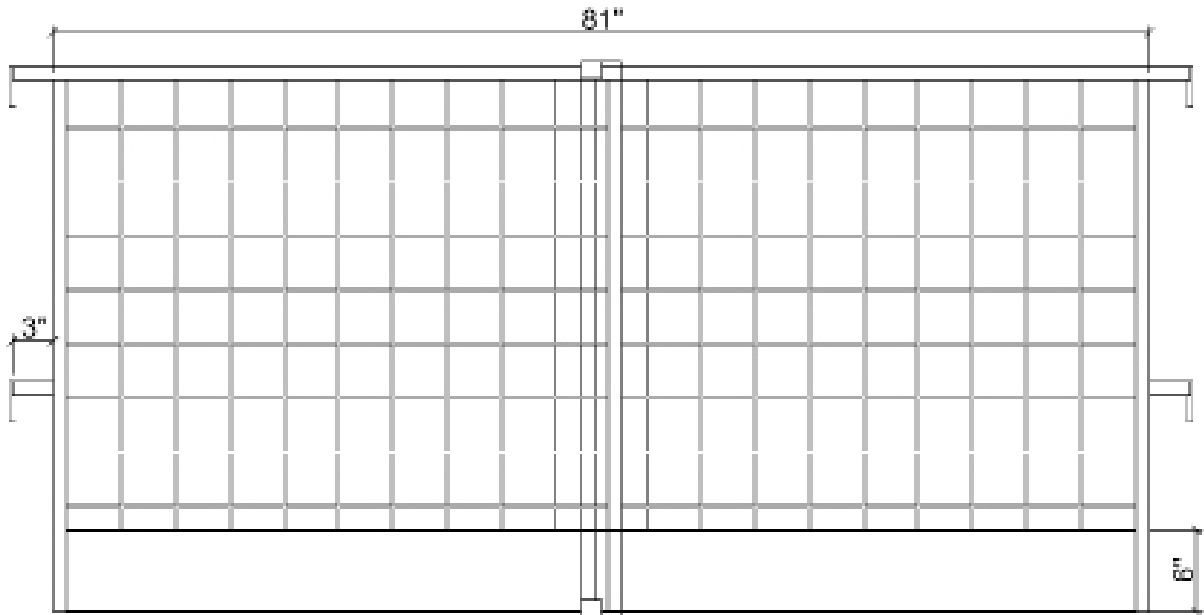

approximate  
adjustable panel  
weight: 60 lbs

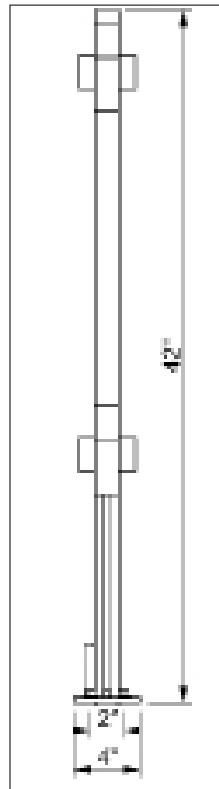
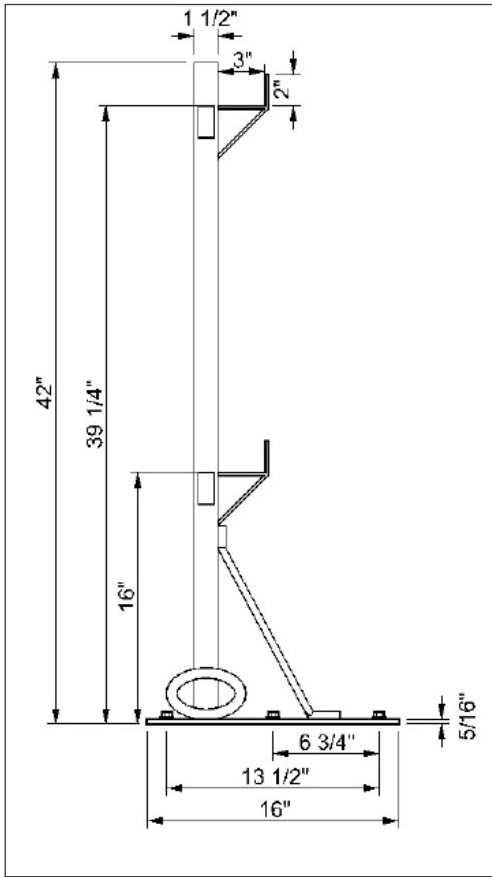

approximate post weight:  
18 lbs

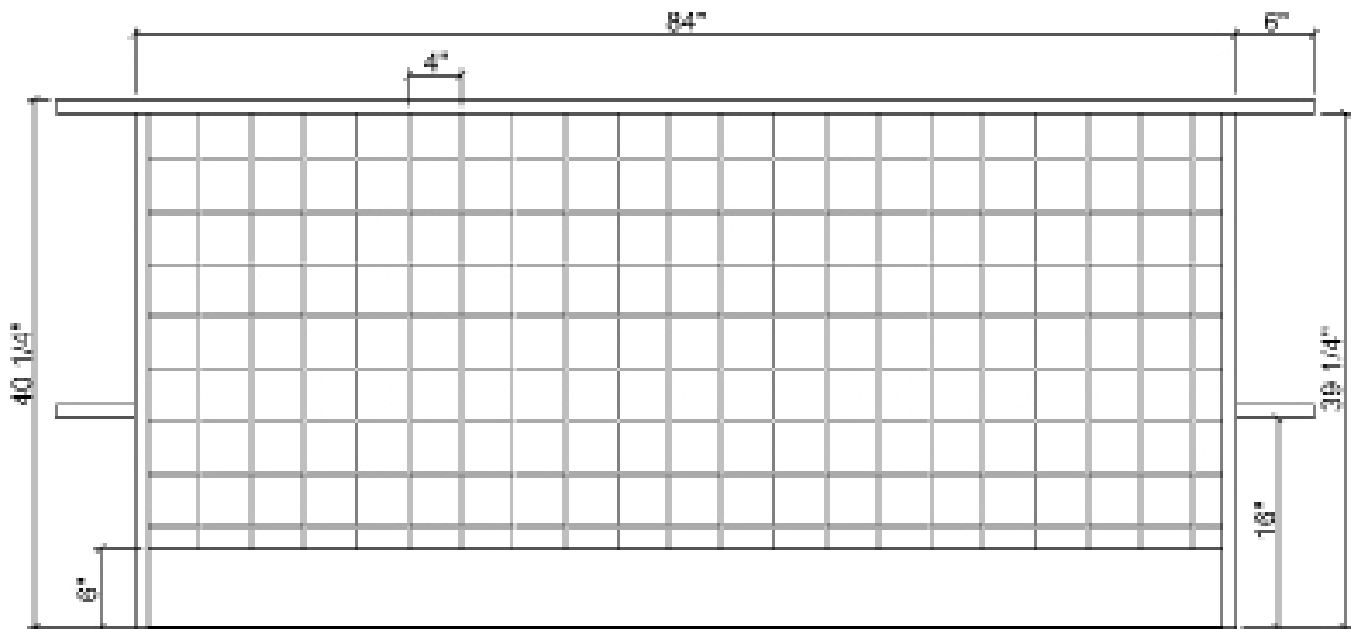

approximate fixed panel weight: 45 lbs

post crate details

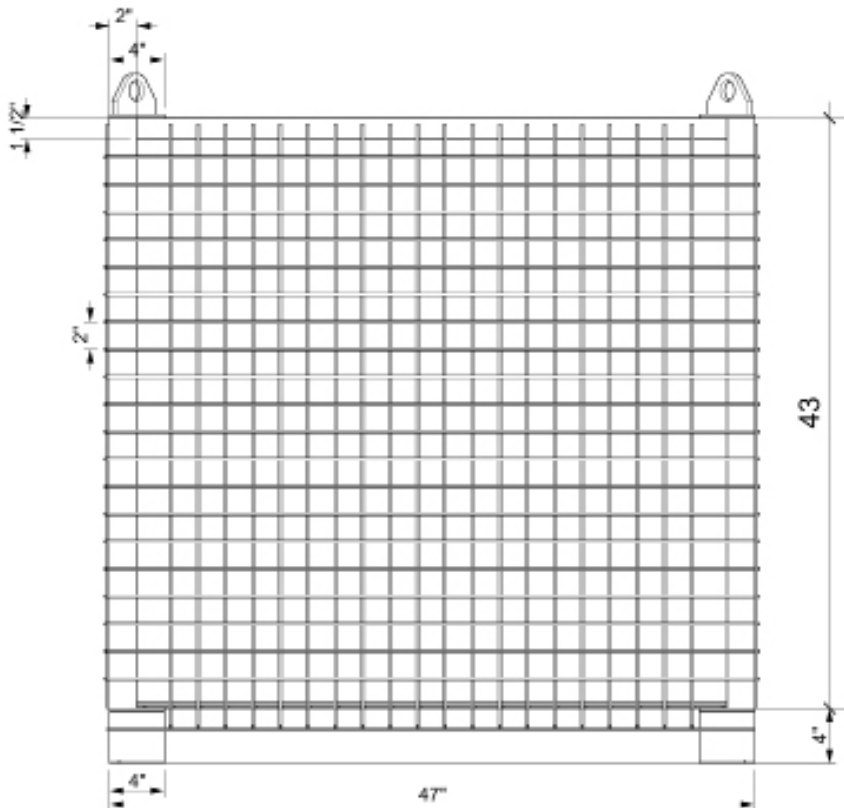
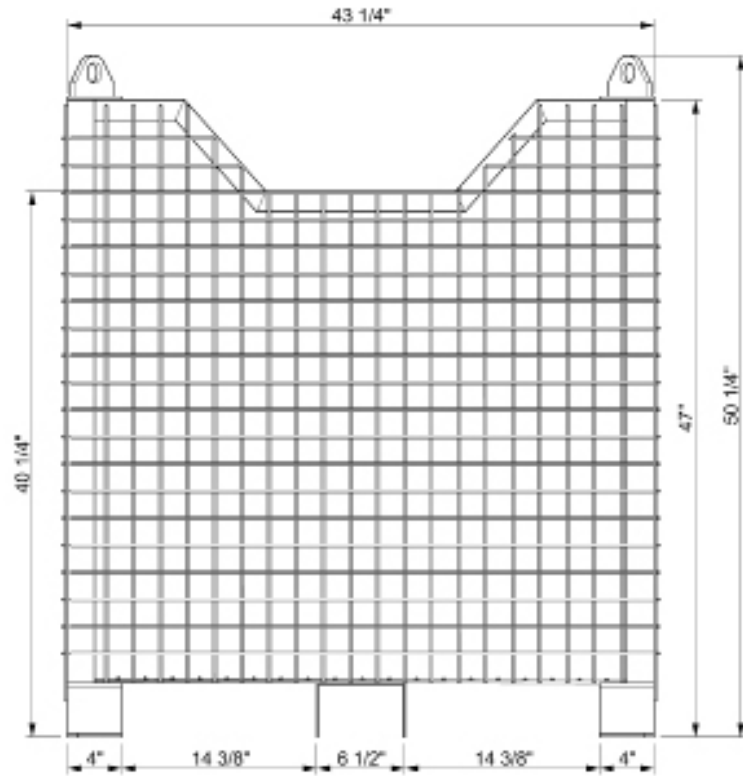

approximate post crate weight:  
250 lbs



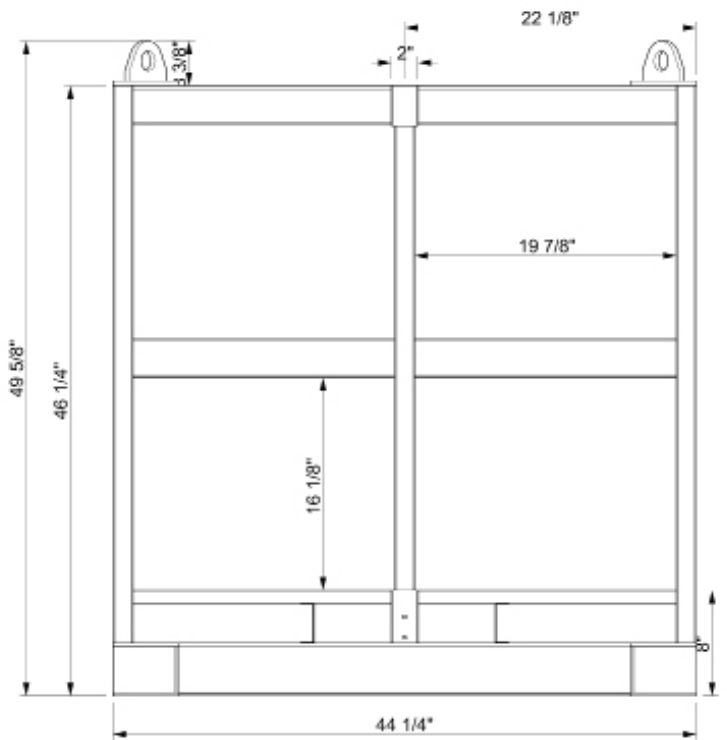
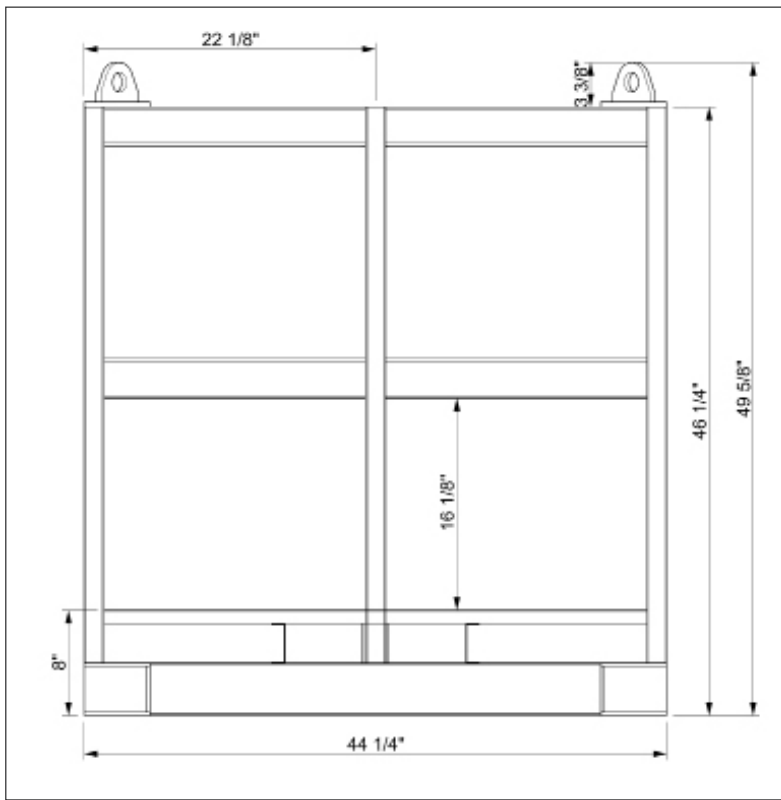
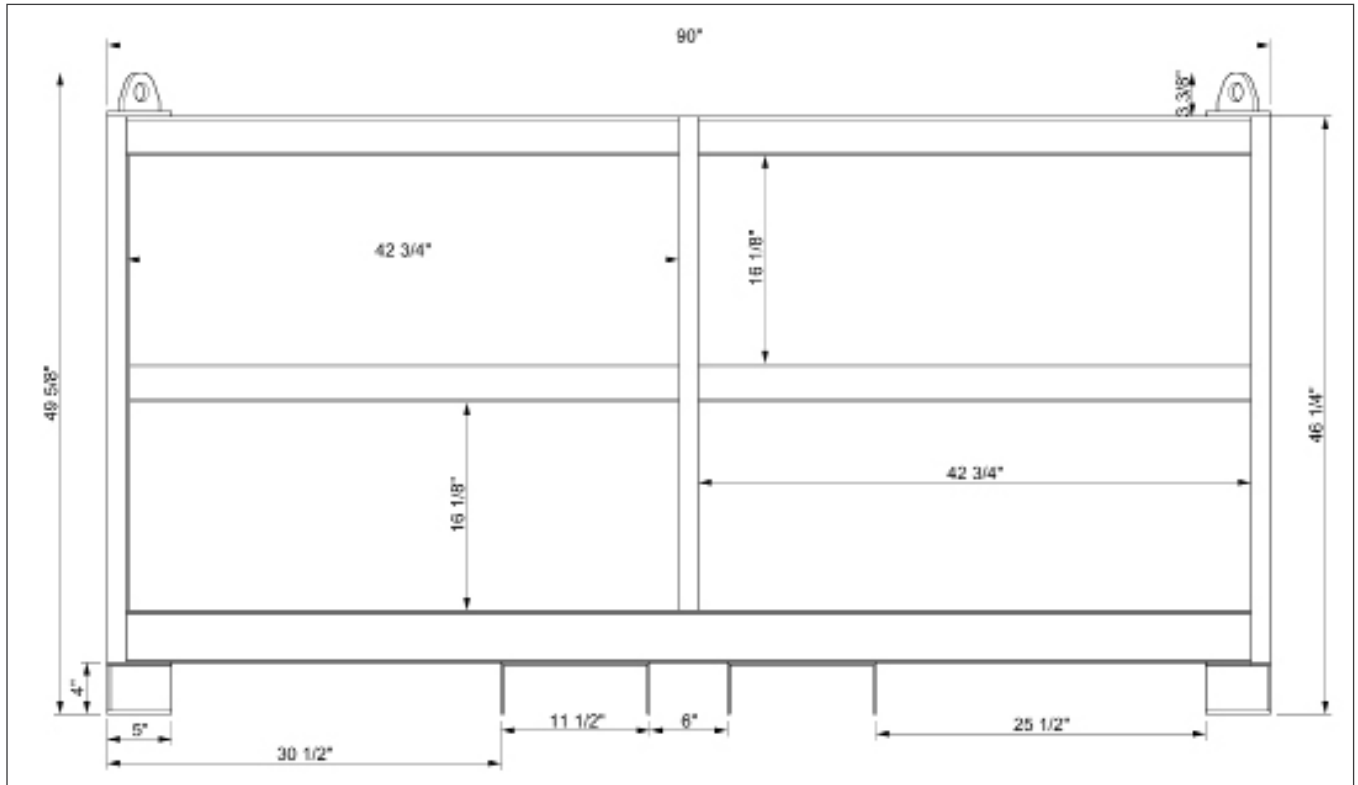

approximate panel crate weight: 270 lbs

EMBED plate details

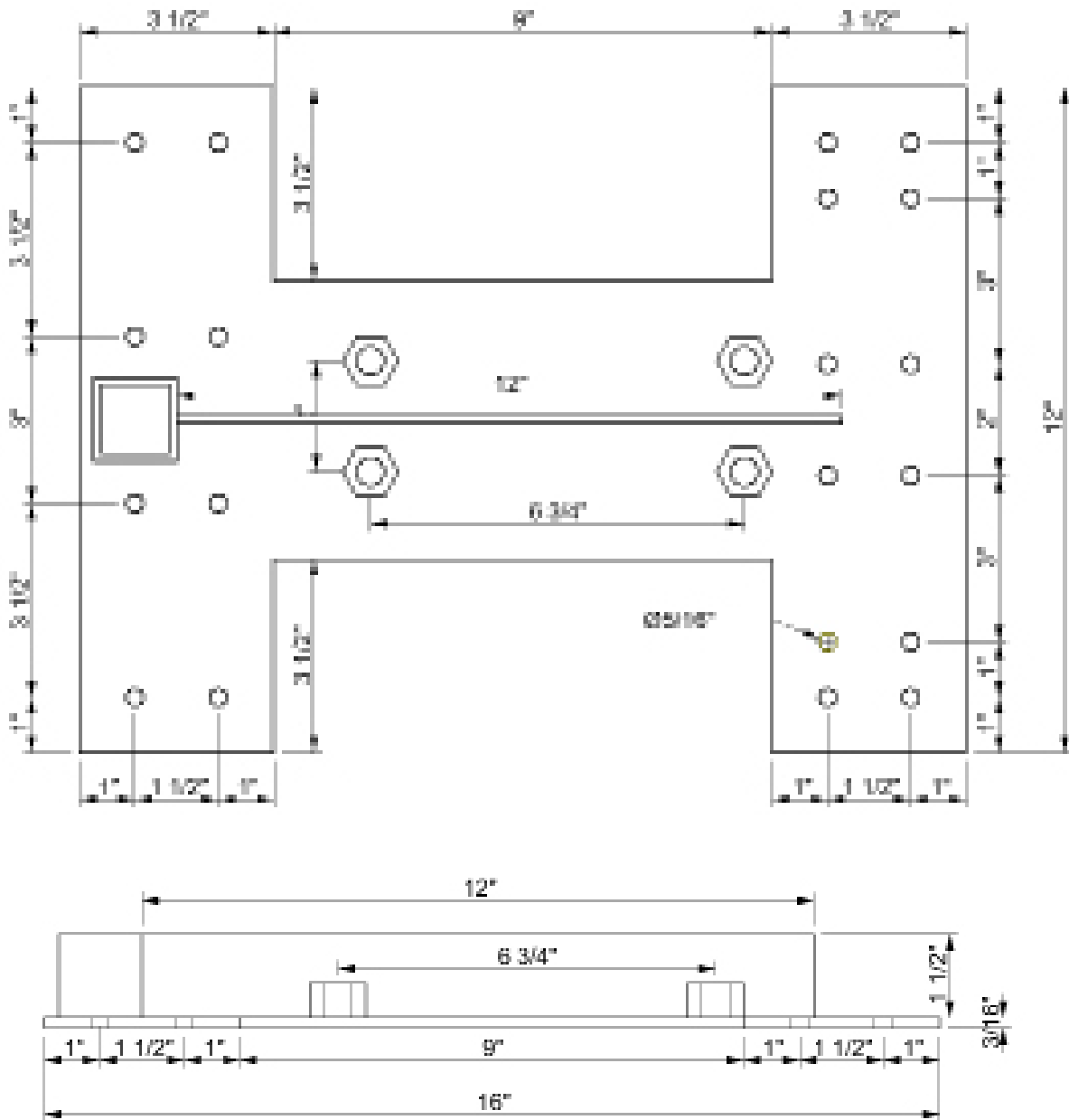

approximate embed plate weight: 8 lbs

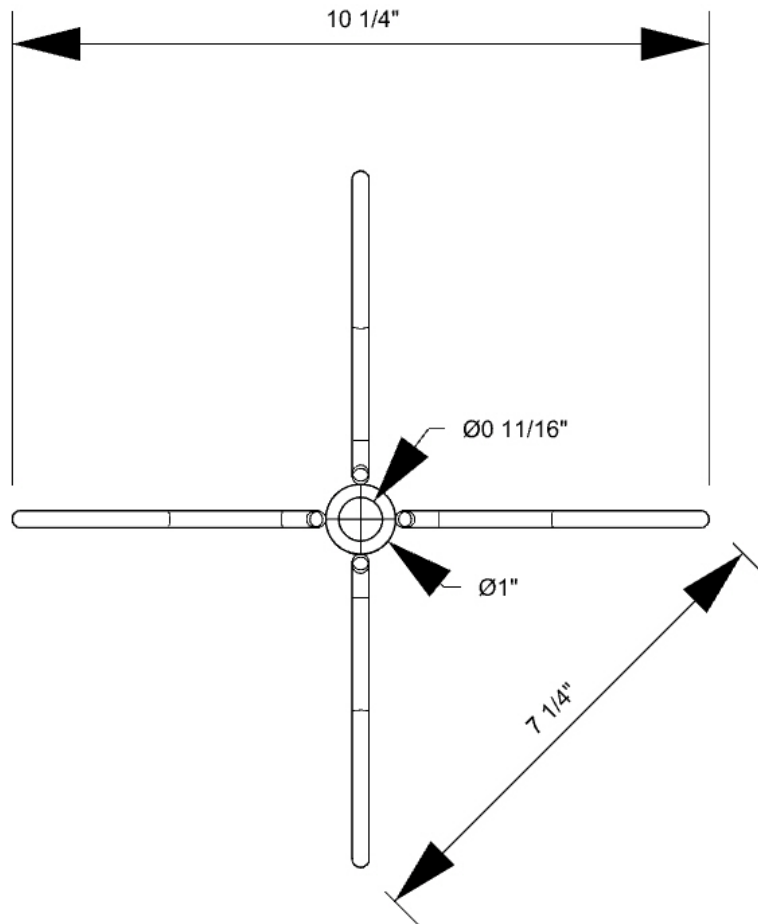

approximate insert weight: 1 lbs

slab CLAMP details

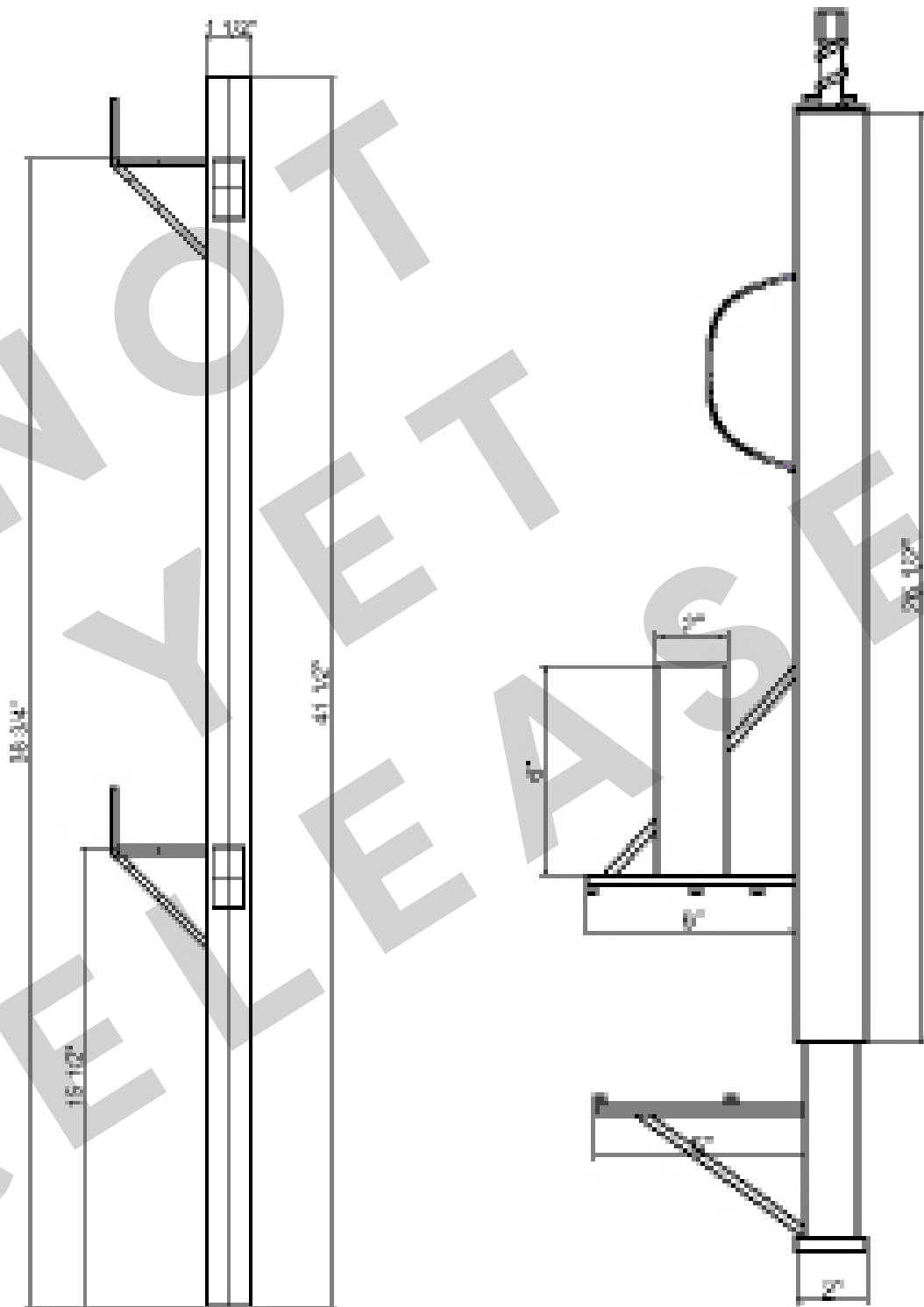

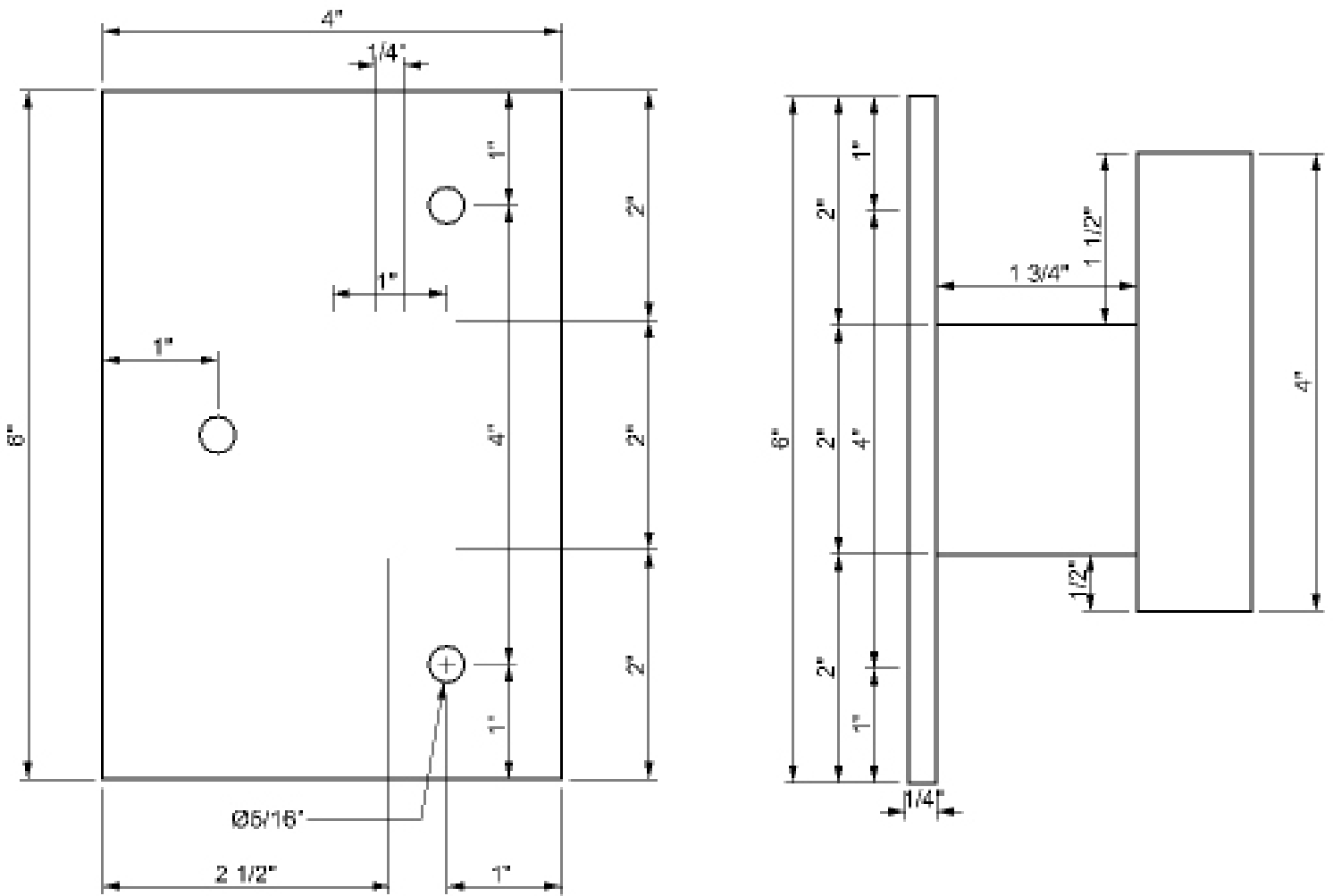

approximate wall bracket weight: 2 lbs

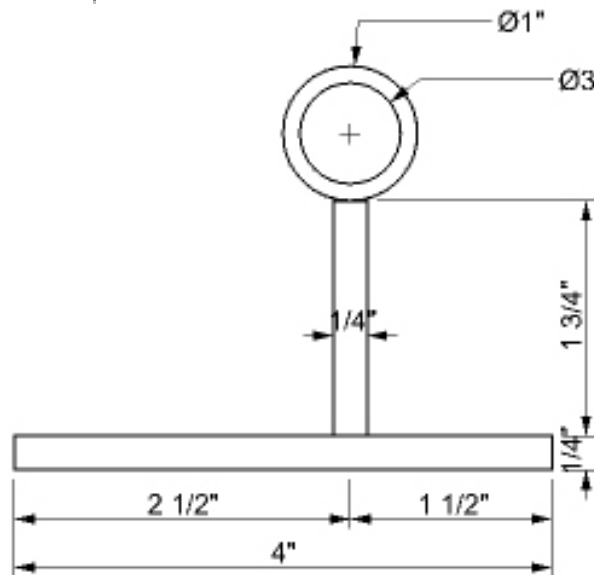

## general inspection information

- a separate inspection form must be filled out for each continuous run of fencing
- use the grid at the bottom of the inspection page to sketch location of run
- each run of fencing requires an inspection form for the posts and panels, the tie-off ring and any attachment accessory being used
- inspections must be carried out immediately prior to installation as well as a minimum of once per year while in use
- for attachment accessories that are installed pre-pour, inspection must be carried out before and after the pour
- each item must meet all of the inspection points in order to pass inspection
- for the tie-off ring, failure on any point requires disposal of post - the tie-off ring shall not be repaired
- for all other items
  - damage to structural members will result in inspection failure and item must be disposed
  - damage to fence panel mesh must be analyzed on a case by case basis to determine reparability
- items that fail inspection must have a repair/dispose form filled out
- use the inspection diagrams on pages 33-40 to indicate location of failure

### inspection examples:



Maximum smooth deflection: ½"  
horizontal - panel acceptable



Maximum number of continuously broken mesh: 2

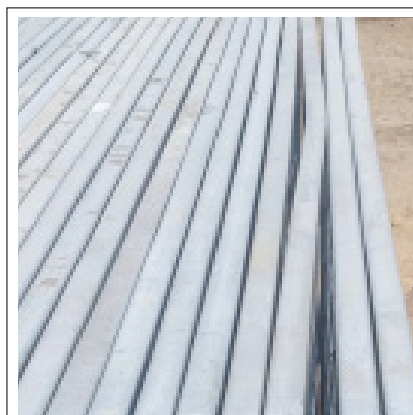

Not adequate - dispose of panel

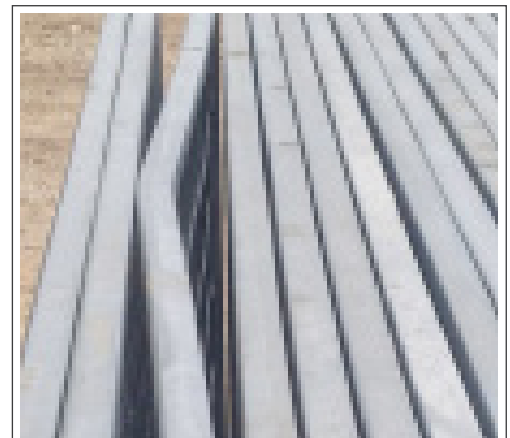

Not adequate - dispose of panel





















**REPAIR/DISPOSE form**

**A SEPARATE REPAIR/DISCARD FORM MUST BE FILLED OUT FOR EACH ITEM THAT DOES NOT PASS INSPECTION**

**USE THE DIAGRAMS ON PAGES 13-16 TO INDICATE LOCATION OF DAMAGE**

DATE \_\_\_\_\_

ITEM DESCRIPTION \_\_\_\_\_

\_\_\_\_\_

REASON FOR INSPECTION FAILURE - LIST ALL REASONS

\_\_\_\_\_  
\_\_\_\_\_  
\_\_\_\_\_  
\_\_\_\_\_

ITEM TO BE:     REPAIRED  
                   REMOVED AND DISPOSED

DESCRIPTION OF REPAIR WORK

\_\_\_\_\_  
\_\_\_\_\_  
\_\_\_\_\_  
\_\_\_\_\_

APPROVED FOR REUSE BY \_\_\_\_\_



A large grid of graph paper for taking notes, consisting of 30 columns and 30 rows of small squares.

---

## safe productivity at the leading edge

Copyright reserved. This document is the exclusive property of Highland Safety Systems. This document may not be copied or otherwise reproduced without the permission of Highland Safety Systems. Highland Safety Systems owns all patents, as applicable. This manual has been reviewed by a licensed engineer. All of the components presented in this manual were designed in collaboration with a licensed engineer.



- a. 200 Terence Matthews Cres.  
Ottawa, ON, Canada  
K2M 2C6
- t. 855.591.7272
- e. [info@highlandsystems.com](mailto:info@highlandsystems.com)
- w. [highlandsystems.com](http://highlandsystems.com)

p010v1.6  
January 2018