

Implementation of Perturb & Observe Algorithm for Constant Power Generation in Grid connected PV system

¹Rahul Dalvi, ²Prof. Pawan C.Tapre

¹PG Student, Dept. of Electrical Engineering, SNDCOE&RC, Yeola, Nashik, Maharashtra

²Dept. of Electrical Engineering, SNDCOE&RC, Yeola, Nashik, Maharashtra

Abstract—With Increase in demand of clean electricity generation in many countries, the increasing techniques of new photovoltaic (PV) systems force the Distribution System for transmission and distribution of electricity. However, the capital cost of PV system and its routine maintenance becomes the major reason to adopt the system widely. By considering this aspect, the distributors of electricity are Focused to ensure fast and smooth transformation between maximum power point tracking and constant power generation so the maximum feeding power of PV systems must be limited. Optimum performance and stable operations are achieved in spite of solar irradiance levels by the new control technique which is proposed. In this strategy, PV output power can be regulated as per desired set point and force to operate the PV system at left side of maximum power point without any stability issues. Constant power generation (CPG) control is much effective strategy in terms of stable transitions, high accuracy and fast dynamics which have been verified.

This system consists of 66 V solar PV panel, boost converter, MPPT controller, inverter, LCL filter and Load. Here, PV system as energy source. The power generated from solar photovoltaic system is controlled by DC-DC boost converter. A modelling of this system is developed in MATLAB/Simulink. The inverter input is 560 V_{DC} and its output is 230 V_{AC} at output where load is connected. The complete design is modelled and verified.

Keywords-Active power control; constant power contro; maximum power point tracking;PV systems; power converters.

I. INTRODUCTION

Due to the mounting demand of electricity, inadequate reserve of fossil fuel and rising prices of conventional sources, photovoltaic (PV) energy becomes a promising substitute. It is a prevalent means of producing clean and renewable power. Due to this reason, the demand of PV generation systems increases and there is a need to extract maximum power from them. So there is need of maximum power point tracking (MPPT) in a PV system. It is a technique

that can operate solar PV systems in such a way that they produce maximum power that can be generated. MPPT tracking system works based on a tracking algorithm which is provided through a control system. Perturb and observe MPPT method is used to make clear understanding for tracking maximum power point (MPP) of PV module under constant and variable irradiation. For this purpose, a two-stage single phase grid-connected PV system model is proposed and simulated. The output of the photovoltaic module is connected with boost converter whose switching is controlled by P & O MPPT techniques to ensure the satisfactory operation of PV module at MPP [1].

II. COMMONLY USED MPPT TECHNIQUES

- A. Constant Voltage Method
- B. Short Circuit Current Method
- C. Incremental conductance method
- D. Perturb and observe Method

This is simplest method of MPPT. In this method we use voltage sensor to sense the PV voltage. So its implementation cost is low. The algorithm of this method is very simple but it reaches very close to the MPP. But not at MPP and keeps disturbing on both the direction. This algorithm has reached very close to the M_{pp} and we can set an appropriate error limit. This is called as P&O method. It is mostly used due to its reliability.

Advantages:

- 1) Its algorithm is simple.
- 2) Easy to implementation.
- 3) It has better accuracy than others methods.

Drawbacks:

This algorithm cannot determine the actual MPP. The output power always oscillates around the MPP but cannot reach at Mpp. This oscillation problem can be decreased by using various minimization techniques.

configuration, where the PV output voltage v_{pv} is directly fed to the PV inverter and has to be higher than the grid voltage level (e.g., 325 V) to ensure the power delivery.

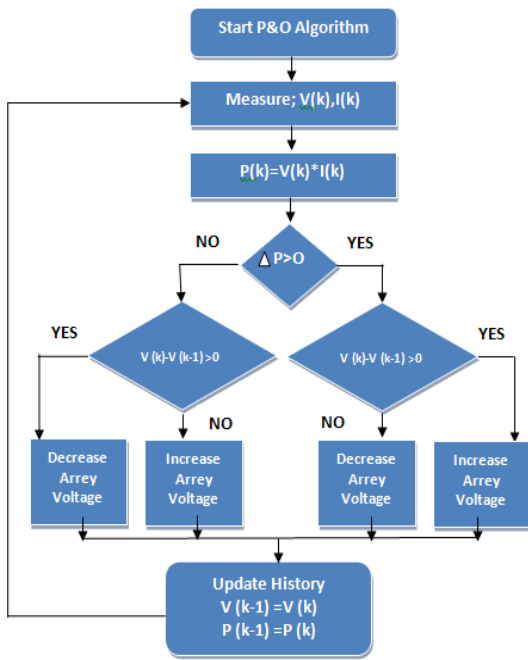

Fig. 1 :Algorithm of P & O Method

III. BLOCK DIAGRAM OF PROPOSED SYSTEM

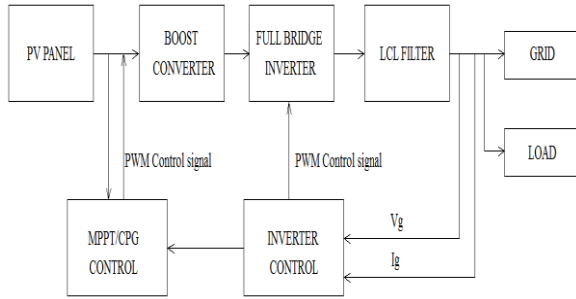

Fig.2: Block diagram of of a two-stage single phase grid-connected PV system.

Fig. 2 shows the basic Block diagram of a two-stage single-phase grid-connected PV system. The CPG control is implemented in the boost converter. The control of the full bridge inverter is realized by using a cascaded control where the dc-link voltage is kept constant through the control of the ac grid current, which is an inner loop. LCL filter is used to filter the output from the inverter. Notably, only an active power is injected to the grid, meaning that the PV system operates at a unity power factor. the two-stage configuration can extend the operating range of both the MPPT and CPG algorithms. In the two-stage case, the PV output voltage v_{pv} can be lower (e.g., at the left side of the MPP), and then, it can be stepped up by the boost converter to match the required dc-link voltage (450 V). This is not the case for the single-stage

IV. DESIGN AND DEVELOPMENT OF TWO-STAGE SINGLE PHASE GRID-CONNECTED PV SYSTEM

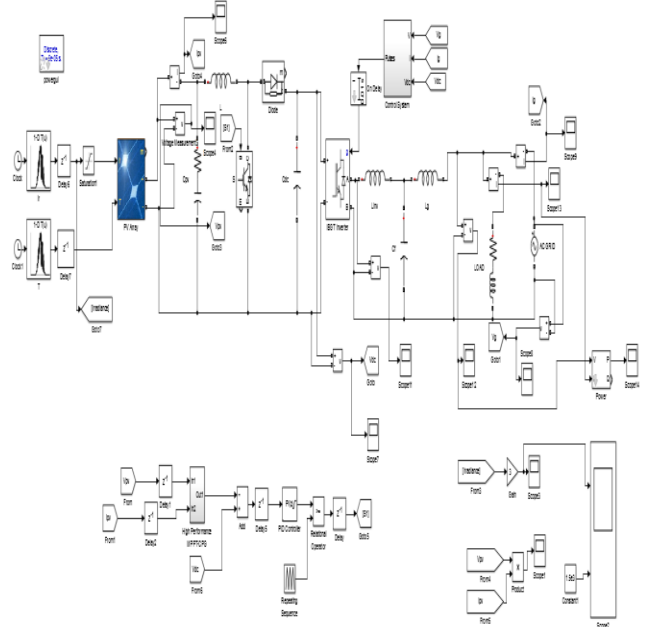

Fig. 3 :Simulation model of two-stage single phase grid-connected PV system

The PV Array block implements an array of photovoltaic (PV) modules. The array is built of strings of modules connected in parallel, each string consisting of modules connected in series. The PV Array block has two inputs that allow you to supply varying sun irradiance (input I_r in W/m^2) and temperature (input T in deg. C) data. The PV Array consists of eight string and each string contains six BP SOLAR BP365TS modules connected in series. At 25 deg. C and with a solar irradiance of $1000 W/m^2$, the string can produce 3000 W. PV array output Voltage is 66 V. The output of the solar panel is a DC voltage of very low magnitude. Hence a boost converter is required for boosting the voltage to higher level without use of the transformer. The primary parts of a support converter are an inductor, a diode and a high recurrence switch. PV panel is connected to boost converter. The P & O Algorithm CPG control is implemented in the boost converter. Then DC voltage is applied to the full bridge inverter where DC supply is converted into AC. Output of a Inverter is controlled through PWM control system. Then output of inverter is fed to LCL filter where output signals are filtered and then fed to the grid. Single phase load is connected at the load end.

The output of the solar panel is a DC voltage of very low magnitude. Hence a boost converter is required for boosting the voltage to higher level without use of the transformer. The primary parts of a support converter are an inductor, a diode and a high recurrence switch Pv panel is connected to boost converter. The P & O Algorithm CPG control is implemented in the boost converter. Then DC voltage is applied to the full bridge inverter where DC supply is converted into AC. Output of a Inverter is controlled through PWM control system. Then output of inverter is fed to LCL filter where output signals are filtered and then fed to the grid. Single phase load is connected at the load end.

V. SIMULATION RESULTS & DISCUSSION

A. Voltage and Current Profile Improvement due to Proposed P & O Algorithm implementation

DC side, PV Array voltage, PV Array Current and MPPT Output voltage results are obtained as shown in Fig.4a, 4b and 4c.

B. Parameters of the PV module BP solar BP365TS at STC

The results are taken by two different arrangements. First result when only solar panel is connected in the circuit without MPPT/CPG algorithm, and second when only MPPT is connected to solar PV panel.

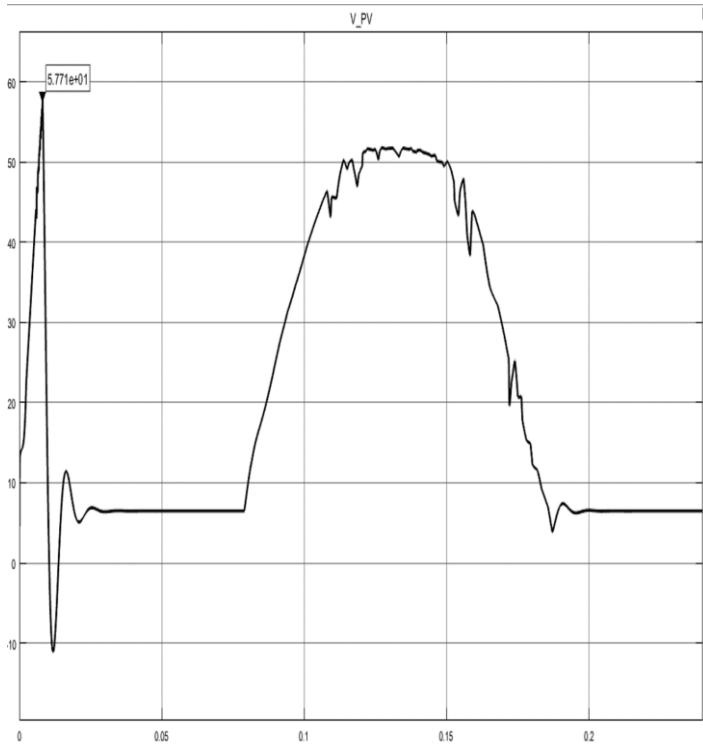

Fig. 4:(a) PV voltage V_{PV}

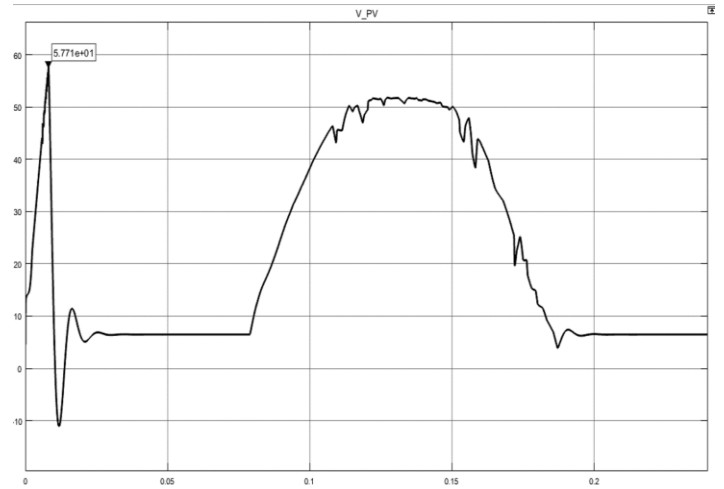

Fig. 4:(b) PV current I_{PV}

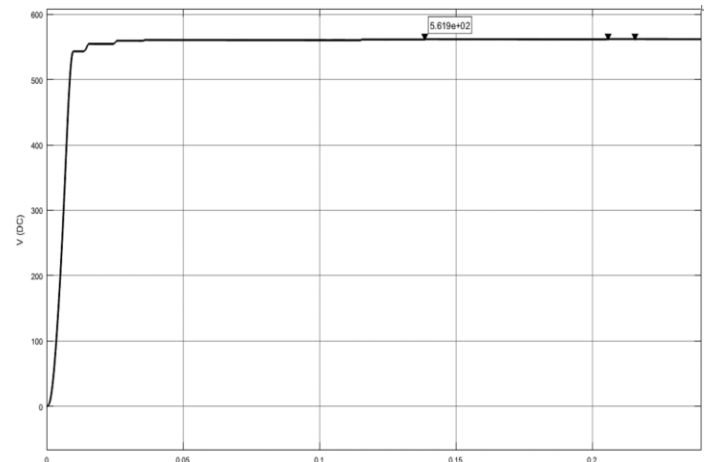

Fig. 4:(c) DC Link Voltage/ MPPT Output Voltage

S. No.	Parameters	PV A	PV B
1	Maximum Power (W)	65.25	65.25
2	Cells per module (Ncell)	18	18
3	Short-circuit current I_{sc} (A)	8.1 A	8.1 A
4	Open circuit voltage $V_o(V)$	11 V	11 V
5	Voltage at MPP V_{mp} (V)	8.7 V	8.7 V
6	Current at MPP I_{mp} (A)	7.5 A	7.5 A
7	Shunt resistance R_{sh}	49.9925	49.9925
8	Series resistance R_s	0.13134	0.13134
9	No. of Parallel strings	40	8
10	Series-connected modules per string	10	6
11	Solar Panel Output Voltage	110	66
12	MPPT Output Voltage	535	560

13	Solar Panel Output Current	100	53.17
14	Solar Panel Output Power (KW)	10	3

1) Solar panel A

Sr. No.	Time (Min)	Solar Voltage (V)	MPPT Voltage (V)
1	10:00	99.19	535.1
2	10:30	100.3	535.2
3	11:00	99.64	535.2
4	11:30	101.0	535.3
5	12:00	101.1	535.3
6	12:30	100.8	535.3
7	1:00	97.63	535.4
8	1:30	69.90	535.4
9	2:00	101.1	535.6
10	2:30	100.8	535.6
11	3:00	30.55	535.6
12	3:30	94.25	535.6
13	4:00	24.59	535.6
14	4:30	2.19	535.7
15	5:00	28.90	535.7
16	5:30	34.4	535.8
17	6:00	36.19	535.8

6	12:30	51.54	560
7	1:00	51.70	560
8	1:30	51.76	560
9	2:00	51.45	560
10	2:30	50.74	560
11	3:00	49.80	560
12	3:30	47.13	560
13	4:00	43.17	560
14	4:30	34.92	560
15	5:00	28.90	560
16	5:30	21.88	560
17	6:00	13.40	560

C. Graphical Results

The following graph shows the V-T characteristics of photovoltaic panel without using MPPT and V-T characteristics of photovoltaic panel with using MPPT.

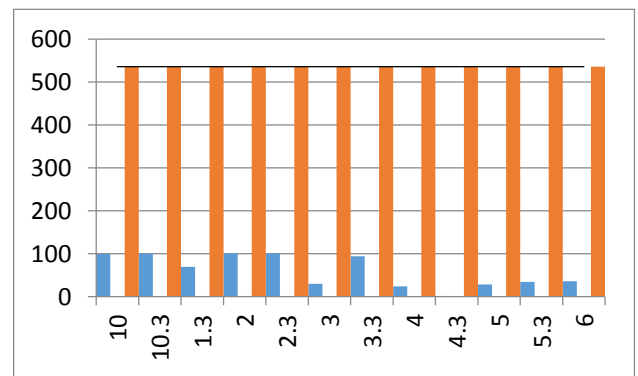

Fi

g.5 (a) V-T characteristics of PV Panel without MPPT

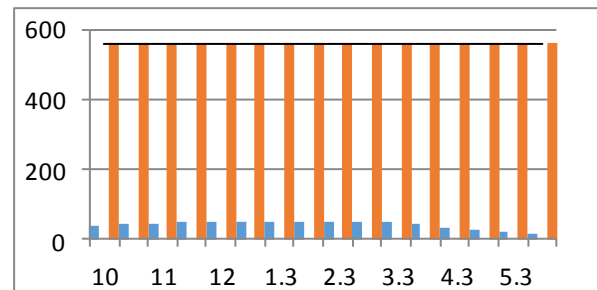

Fig.5:(b) V-T characteristics of PV Panel with MPPT

Parameters	Specification
PV Panel	3 KW, 60 V, 53.17 A
Boost converter	L = 1.8 mH
PV-side capacitor	C _{pV} = 1000 μF
DC-link capacitor	C _{dc} = 1100 μF
LCL-filter	L _{inv} =4.8mH, L _g =4 mH, C _f =330μF
Switching frequency	Boost converter f _b = 16 kHz Full-Bridge inverter f _{inv} =8 kHz
DC-link voltage	V _{dc} = 450 V
Grid nominal voltage	V _g = 230 V
Grid nominal frequency	ω ₀ = 2 π×50 rad/s

2) Solar panel A

Sr. No.	Time (Min)	Solar Voltage (V)	MPPT Voltage (V)
1	10:00	38.27	560
2	10:30	43.75	560
3	11:00	45.61	560
4	11:30	49.45	560
5	12:00	49.04	560

Table I. Simulation Parameters

VI. CONCLUSION

In a single phase two stage grid connected PV System MPPT and CPG controller is implemented. P&O algorithm of MPPT controls the output of PV Panel at constant magnitude irrespective of sun irradiance. This P &O algorithm is provided at the boost converter. He MPPT technique must be

implemented with every PV system. As MPPT technique enhances the overall Performance of PV system. Model of classical MPPT technique is established using single diode model of PV cell. Two PV panels are taken with 110 V and 66 V voltage rating. Though the size and ratings of two panels are different, both the PV panels are produced nearly same DC voltage with higher magnitude after boost converter because of P&O algorithm of MPPT. Hence high voltage amplification is mandatory for grid synchronization and to achieve low total harmonic distortion (THD).

From the simulation result, effectiveness of the proposed control solution in terms of reduced over-shoots, minimized power losses, and fast dynamics have been verified. Proposed system can ensure a stable constant power generation operation.

REFERENCES

- [1]. Y. Yang, H. Wang, F. Blaabjerg, and T. Kerekes, "A hybrid power control concept for PV inverters with reduced thermal loading," *IEEE Trans. Power Electron.*, vol. 29, no. 12, pp. 6271–6275, Dec. 2014.
- [2]. A. Ahmed, L. Ran, S. Moon, and J.-H. Park, "A fast PV power tracking control algorithm with reduced power mode," *IEEE Trans. Energy Conversion*, vol. 28, no. 3, pp. 565–575, Sept. 2013.
- [3]. Y. Yang, F. Blaabjerg, and H. Wang, "Constant power generation of photovoltaic systems considering the distributed grid capacity," in *Proc. of APEC*, pp. 379–385, Mar. 2014.
- [4]. R. G. Wandhare and V. Agarwal, "Precise active and reactive power control of the PV-DGS integrated with weak grid to increase PV penetration," in *Proc. of PVSC*, pp. 3150–3155, Jun. 2014.
- [5]. W. Cao, Y. Ma, J. Wang, L. Yang, J. Wang, F. Wang, and L. M. Tolbert, "Two-stage PV inverter system emulator in converter based power grid emulation system," in *Proc. of ECCE*, pp. 4518–4525, Sept. 2013.
- [6]. A. Urtasun, P. Sanchis, and L. Marroyo, "Limiting the power generated by a photovoltaic system," in *Proc. of SSD*, pp. 1–6, Mar. 2013.
- [7]. S. B. Kjaer, J. K. Pedersen, and F. Blaabjerg, "A review of single-phase grid-connected inverters for photovoltaic modules," *IEEE Trans. Ind. Appl.*, vol. 41, no. 5, pp. 1292–1306, Sept. 2005.
- [8]. F. Blaabjerg, R. Teodorescu, M. Liserre, and A. V. Timbus, "Overview of control and grid synchronization for distributed power generation systems," *IEEE Trans. Ind. Electron.*, vol. 53, no. 5, pp. 1398–1409, Oct. 2006.
- [9]. A. Thenkani, ' Dr.N.Senthil Kumar,"Design of Optimum Maximum Power Point Tracking Algorithm For Solar Panel" *International Conference on Computer, Communication and Electrical Technology – ICC CET 2011*, 18th & 19th March, 2011
- [10]. Reza Reisi, Ali, Mohammad Hassan Moradi, and Shahriar Jamasb. "Classification and comparison of maximum power point tracking techniques for photovoltaic system: A review", *Renewable and Sustainable Energy Reviews*, 2013.
- [11]. Ei Shwe Zin Phyoo, Kyaw Soe Lwin, Hla Myo Tun "Microcontroller Based Solar Smart Charge Controller using MPPT" *ISSN 2319-8885 Vol.03,Issue.06, May-2014, Pages:0997-1000*
- [12]. Adel A. Elbaset, Ahmed Emad-Eldin Hussein, Ayman Brisha, Ramadan Mahmoud Mostafa2 "Implementation of a PIC-based, Photovoltaic Maximum Power Point Tracking Control System" *International Journal of Emerging Technology and Advanced Engineering Website: www.ijetae.com (ISSN 2250-2459, ISO 9001:2008 Certified Journal, Volume 4, Issue 5, May 2014)*
- [13]. A. Mamun, M. F. Elahi, M. Quamruzzaman, M. U. Tomal4 Design and Implementation of Single Phase Inverter *International Journal of Emerging Technology and Advanced Engineering Website: www.ijetae.com (ISSN 2250-2459, Volume 2, Issue 1, February 2012)*
- [14]. Bijoyprakash Majhi "Analysis of Single-Phase SPWM Inverter" A Thesis Submitted In Partial Fulfillment Of The Requirements Forthe Degree Of Bachelor Of Technology In Electrical Engineering National Institute of Technology, Rourkela May 2012
- [15]. Nishit Kapadia, Amit Patel, Dinesh Kapadia "Simulation and design of low cost single phase solar inverter"
- [16]. Gaurav Arora, Neha Aggarwal, Debojyoti Sen, Prajwal Singh "Design Of Solar Power Inverter" *National conference on Renewable Energy and Environment (NCREE-2015) IMS Engineering College, Ghaziabad Vol. 2, Special Issue 1, May 2015*
- [17]. Kumar Siddhant "implementation of fractional open circuit voltage mppt algorithm in a low cost microcontroller" *national institute of technology, rourkela may 2014 a thesis submitted in partial fulfillment of the requirements for the degree of bachelor of technology in electrical engineering.*