

# INSTALLATION and OPERATION MANUAL

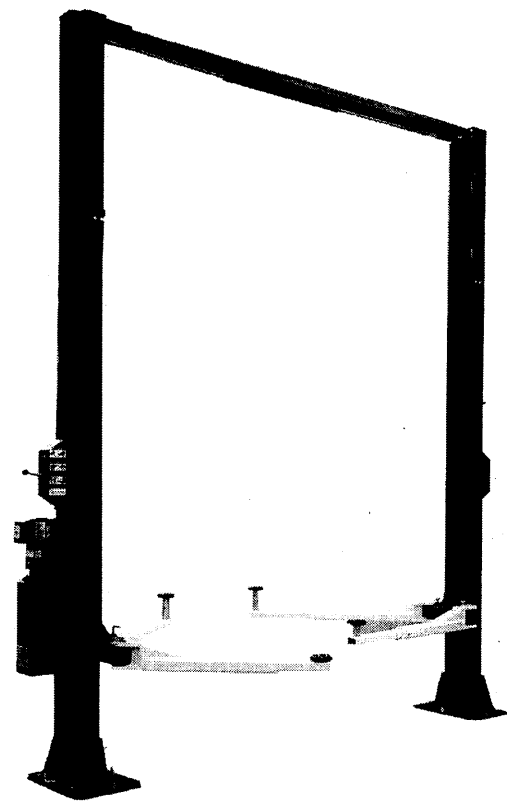

**9K 2N1 2 POST**  
**S290S   - R/B/M,1/3**

**READ and SAVE THIS  
INSTRUCTION MANUAL**

# TABLE OF CONTENTS

	PAGE
<b>1 SAFETY AND OPERATING INSTRUCTIONS .....</b>	<b>1</b>
<b>2 SPECIFICATIONS.....</b>	<b>2</b>
<b>3 CONTENTS.....</b>	<b>3</b>
<b>4 INSTALLATION REQUIREMENTS AND TOOLS .....</b>	<b>3</b>
<b>5 INSTALLATION INSTRUCTIONS .....</b>	<b>4</b>
5.1 UNPACKING PROCEDURE .....	4
5.2 BAY LAYOUT.....	5
5.3 SAFETY SHUT-OFF BAR INSTALLATION .....	5
5.4 SAFETY SHUT-OFF BAR ADJUSTMENT .....	6
5.5 TOWER POSITIONING AND SETUP .....	7
5.6 ROUTING OF EQUALIZATION CABLE.....	8
5.7 ARM INSTALLATION .....	9
5.8 ARM LOCKS INSTALLATION .....	10
5.9 SAFETY RELEASE CABLE ROUTING AND ADJUSTMENT .....	11
5.10 POWER PACK INSTALLATION.....	12
5.11 HYDRAULIC SYSTEM INSTALLATION .....	13
5.12 HYDRAULIC SYSTEM BLEEDING .....	14
5.13 TOWER POSITIONING AND ANCHORING .....	15
5.14 SHIMMING OF THE REMAINING TOWER.....	16
<b>6 LIFT MAINTENANCE GUIDLINES.....</b>	<b>17</b>
6.1 SAFETY INSTRUCTIONS.....	17
6.2 PERIODIC MAINTENANCE.....	17
<b>7 SAFETY AWARENESS .....</b>	<b>18</b>
<b>8 PARTS MANUAL .....</b>	<b>19</b>
8.1 LIFT ASSEMBLY.....	19
8.2 LIFT ASSEMBLY PARTS LIST.....	20
8.3 HYDRAULIC SYSTEM .....	22
8.4 HYDRAULIC SYSTEM PARTS LIST .....	23
8.5 POWER PACK:.....	24
8.6 POWER PACK PARTS LIST:.....	25

## 1 SAFETY AND OPERATING INSTRUCTIONS

1. Read all instructions.
2. Inspect lift daily. Do not operate if it malfunctions or problems have been encountered.
3. Never attempt to overload the lift. The manufacturer's rated capacity is shown on the identification label on the power side column. Do not override the operating controls or the warranty will be void.
4. Only trained and authorized personnel should operate the lift. Do not allow customers or bystanders to operate the lift or be in the lift area.
5. Position the lift support pads to contact the vehicle manufacturer's recommended lifting points. Raise the lift until the pads contact the vehicle. Check pads for secure contact with the vehicle, then raise the lift to the desired working height.
6. Some pickup trucks may require an optional truck adapter to clear running boards or other accessories. **NOTE:** Always use all 4 arms to raise and support vehicle.
7. **Caution! Never work under the lift unless the mechanical safety locks are engaged.**
8. Note that the removal or installation of some vehicle parts may cause a critical load shift in the center of gravity and may cause the vehicle to become unstable. Refer to the vehicle manufacturer's service manual for recommended procedures.
9. Always keep the lift area free of obstruction and debris. Grease and oil spills should always be cleaned up immediately.
10. Never raise vehicle with passengers inside.
11. Before lowering check area for any obstructions.
12. Before driving vehicle between the towers, position the arms to the drive-through position to ensure unobstructed clearance. Do not hit or run over arms as this could damage the lift and/or vehicle.
13. Before removing the vehicle from the lift area, position the arms to the drive-through position to prevent damage to the lift and /or vehicle.
14. Care must be taken as burns can occur from touching hot parts.
15. Do not operate equipment with a damaged cord or if the equipment has been dropped or damaged – until a qualified serviceman has examined it.
16. Do not let cord hang over table, bench or counter or come in contact with hot manifolds or moving fan blades.
17. If an extension cord is necessary, a cord with a current rating of two or more than that of the equipment should be used. Cords rated for less current than the equipment may overheat. Care should be taken to arrange the cord so that it will not be tripped over or pulled.
18. Always unplug the equipment from electrical outlet when not in use. Never use the cord to pull the plug from the outlet. Grasp plug and pull to disconnect.

## 2 SPECIFICATIONS

Capacity:  
 Overall Width:  
 Width Between Columns:  
 Drive-Thru Width:  
 Overall Height:  
 Under Bar Clearance:  
 Height to Lowered Lift Pads:  
 Height to Lift Pad (3" Adapter):  
 Height to Lift Pad (6" Adapter):  
 Front Arm Retracted Length:  
 Front Arm Extended Length:  
 Rear Arm Retracted Length:  
 Rear Arm Extended Length:  
 Maximum Lifting Height (6" Adapter):  
 Lift Time:  
 Power Requirements (Standard):

9000 lbs.	4082 kg
135 7/8"	3451 mm
110"	2794 mm
90 1/2"	2299 mm
144"	3658 mm
140"	3556 mm
4 1/2"	114 mm
7 1/2"	191 mm
10 1/2"	267 mm
33"	838 mm
51"	1295 mm
37 1/2"	953 mm
59 1/2"	1511 mm
79 1/4"	2013 mm
45 seconds	
230 Volts AC, 1 Ph., 60Hz.	

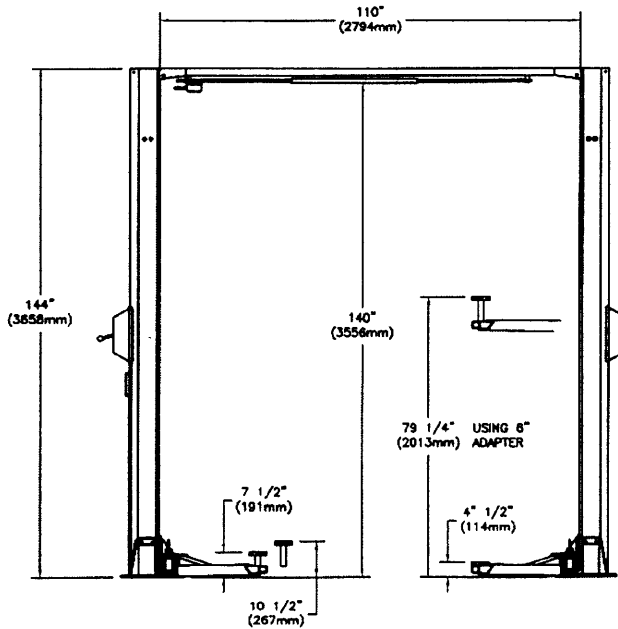

Figure 1 – Front View

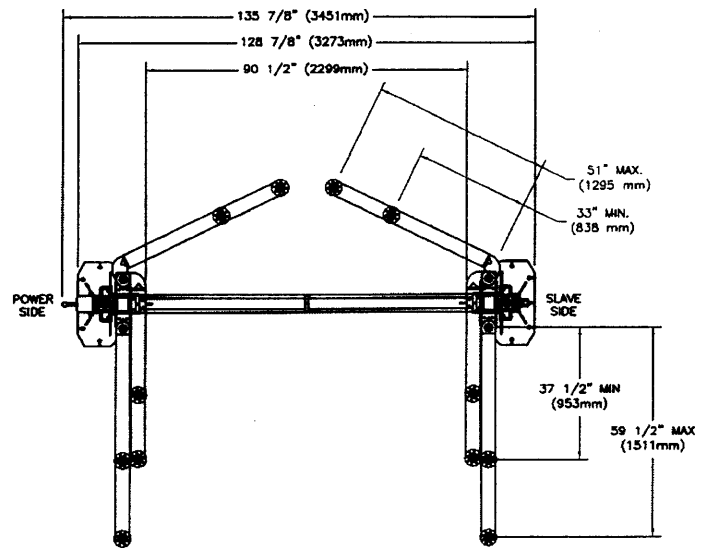

Figure 2 – Top View

### 3 CONTENTS

The complete lift is contained in two (2) packages:

1. The **main structural components** are packed in a steel frame.
2. The remaining parts are packed in an **accessory box**.

#### **Main Structural Components includes:**

- 1pc. - Power side tower and carriage assembly
- 1pc. - Slave side tower and carriage assembly
- 1pc. - Crossmember
- 1pc. - Actuator Bar w/ foam

#### **Accessory box contents:**

- 4pcs. - Locking Arm Assembly w/arm pins
- 2pcs. - Safety Covers w/Decals
- 1pc. - Hardware Package w/Packing List
- 1pc. - Actuator Extension
- 1pc. - Actuator Mounting Bracket
- 1pc. - Power Pack
- 4pc. - Arm Locks
- 1pc. - Safety Release Cable
- 1pc. - Hydraulic Hose (Long)
- 1pc. - Hydraulic Hose (Short)
- 2pcs. - Equalizing Cable w/Hex Nuts
- 1pc. - ALI manual "Lifting It Right"
- 1pc. - Automotive Lift Safety Tips
- 1pc. - Automotive Lift, Operation, Inspection and Maintenance manual
- 1pc. - "ALI" Quick Reference Guide
- 1pc. - Owner's manual
- 1pc. - Safety Shut-off Microswitch Assembly (Components)

### 4 INSTALLATION REQUIREMENTS AND TOOLS

**IMPORTANT: It is the user's responsibility to provide a satisfactory installation area for the lift. Lifts should only be installed on level concrete floors with a minimum thickness of five (5) inches or 130 mm. Concrete must have a minimum strength of 4000 psi or 30 MPa and should be aged thirty (30) days prior to installation. Please consult the architect, contractor or engineer if doubt exists as to the strength and feasibility of the floor to enable proper lift installation and operation.**

**It is the user's responsibility to provide all wiring for electrical hook-up prior to installation and to insure that the electrical installation conforms to local building codes. Where required, it is the user's responsibility to provide an electrical isolation switch located in close proximity to the lift that will enable emergency stop capability and isolate electrical power from the lift for any servicing requirements.**

## Tools Required:

- a. 16ft. Measuring Tape
- b. Chalk Line
- c. Rotary Hammer Drill
- d. 3/4" diameter Masonry Drill Bit
- e. Hammer
- f. SAE Wrenches and Ratchet Set
- g. 2ft. Level
- h. 4ft. Level
- i. Crow Bar
- j. 12ft. Step Ladder
- k. Side Cutters
- l. Screwdrivers
- m. 4" x 4" Wooden Blocks (for unpacking)

## 5 INSTALLATION INSTRUCTIONS

When the lift arrives on site:

- Read the owner's manual and make sure the installation instructions are fully understood.
- Check for any freight damages.
- Check the contents of the accessory and hardware boxes to make sure no parts are missing.
- Gather all the tools listed above.

### 5.1 UNPACKING PROCEDURE

1. **Important!** Place the main structural components on wooden blocks so that the steel shipping frames can be removed.
2. Remove the plastic wrapping.
3. Remove the crossmember, and the actuator bar.
4. Unbolt the steel shipping frames.
5. Lay each tower on the floor with the carriage side up.
6. Check the installation area for obstructions. (Lights, Heating Ducts, Ceiling, Floor Drains, etc.)
7. Prepare the bay by selecting the location of the lift relative to the walls. Clear the installation area of all packaging materials to avoid trip hazards. Draw a chalk line on the floor to represent the centerline of the bay then draw a second chalk line at 90° for locating the lift towers. Refer to **Figure 3**.

## 5.2 BAY LAYOUT

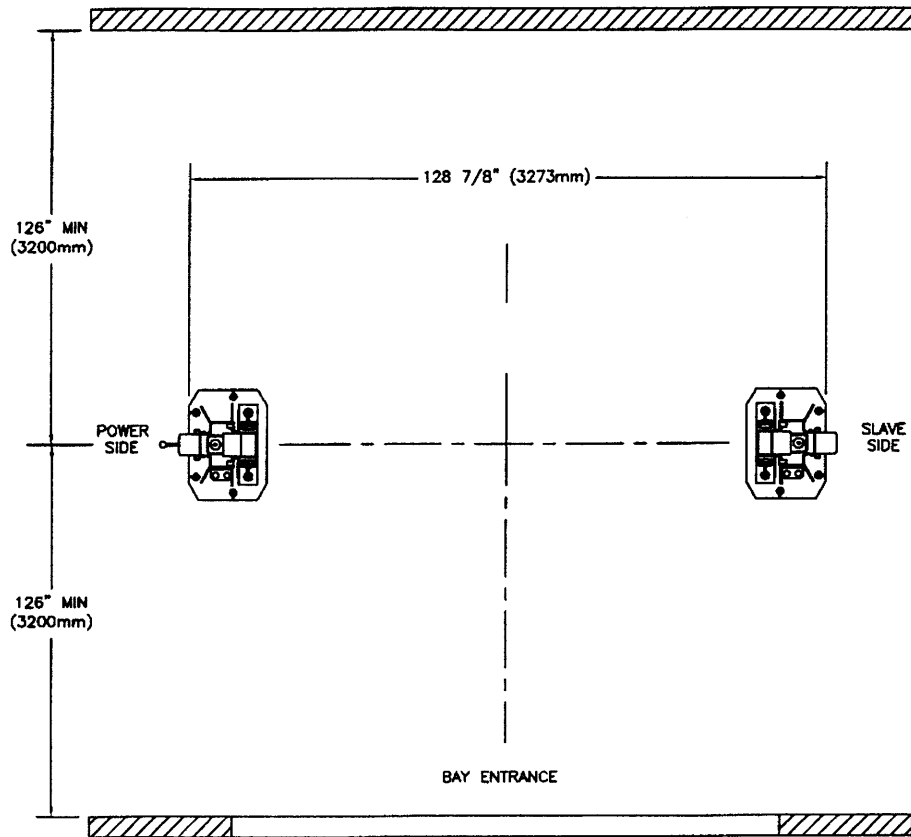

Figure 3 – Bay Layout

## 5.3 SAFETY SHUT-OFF BAR INSTALLATION

**Note:** The safety shut off will disconnect the power to the power pack when an obstruction touches the padded bar or the carriages reach their maximum height. The safety shut off switch is factory pre-wired. Refer to Figure 4.

Note: This procedure can be done on the floor.

1. Attach the Actuator Mounting Bracket (1-1378) to the crossmember using one 1/4" NC x 3/4" lg. hex head bolt (6-0178), one 1/4" ID lockwasher (6-0056), and one 1/4" NC hex nut (6-0032).
2. Attach the Actuator Bar to the Actuator Mounting Bracket using one 1/4" NC x 1 1/2" lg. hex head bolt (6-0205), one 1/4" ID lockwasher (6-0056), and one 1/4" NC hex nut (6-0032).
3. Slide Safety Shut-Off Microswitch Assembly over the open end of actuator bar and bolt the assembly to the crossmember using two (2) 1/4" NC x 3/4" lg. hex head bolts (6-0178), two (2) 1/4" ID lockwashers (6-0056), and two (2) 1/4" NC hex nut (6-0032).

4. Install the  $\frac{1}{4}$ " NC x 2" lg. hex bolt (6-0741) into the actuator extension (1-1379) then attach the  $\frac{1}{4}$ " NC hex nut (6-0032) from the other side to hold the bolt in place.

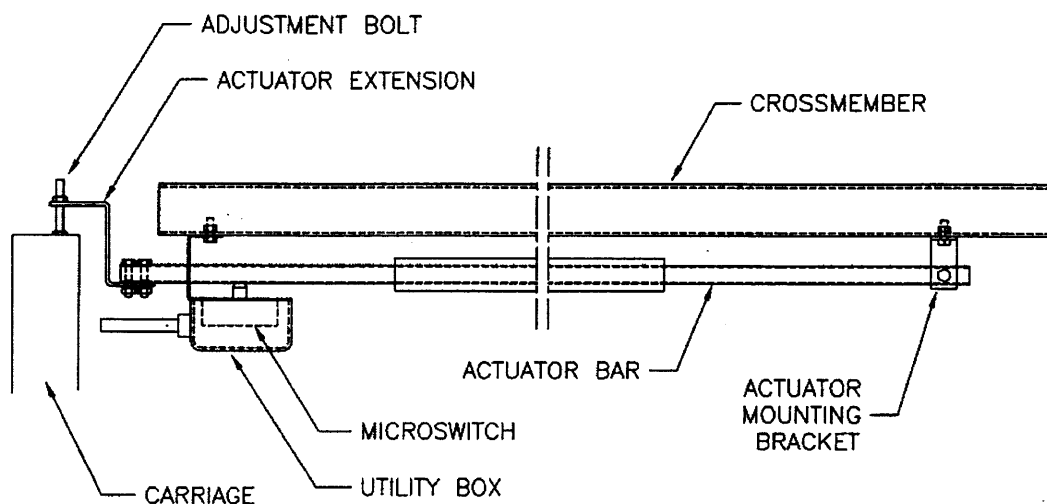

**Figure 4 – Safety Shut-Off Bar Installation**

#### **5.4 SAFETY SHUT-OFF BAR ADJUSTMENT**

**Note: This procedure must be done last. Refer to Figure 4.**

1. When the lift is fully installed, leveled and operational, extend the carriages to their full upper limit.
2. Lower the carriages about  $\frac{1}{4}$ " to  $\frac{1}{2}$ ".
3. Bolt the Actuator Extension onto the open end of actuator bar using two (2)  $\frac{1}{4}$ " NC x  $1\frac{1}{4}$ " lg. hex head bolts (6-0027), two (2)  $\frac{1}{4}$ " ID lockwashers (6-0056), and two (2)  $\frac{1}{4}$ " NC hex nuts (6-0032).
4. Adjust the  $\frac{1}{4}$ " NC x 2" lg. hex bolt so that the end of the bolt is in contact with the carriage. Tighten the  $\frac{1}{4}$ " NC hex nut on the bolt.



## 5.5 TOWER POSITIONING AND SETUP

1. Locate the power side and slave side towers and position them as shown in **Figure 3**. Double check all the dimensions in the layout.
2. Using a stepladder, install the crossmember using eight (8) ½"-16UNC x 1 ¼" lg. hex head bolts, eight (8) ½" ID lock washers, eight (8) ½" hex nuts and eight (8) ½" flat washers. See **Figure 5**
3. Check the towers to make sure they are located, and positioned in the correct location. Refer to **Figure 3**.

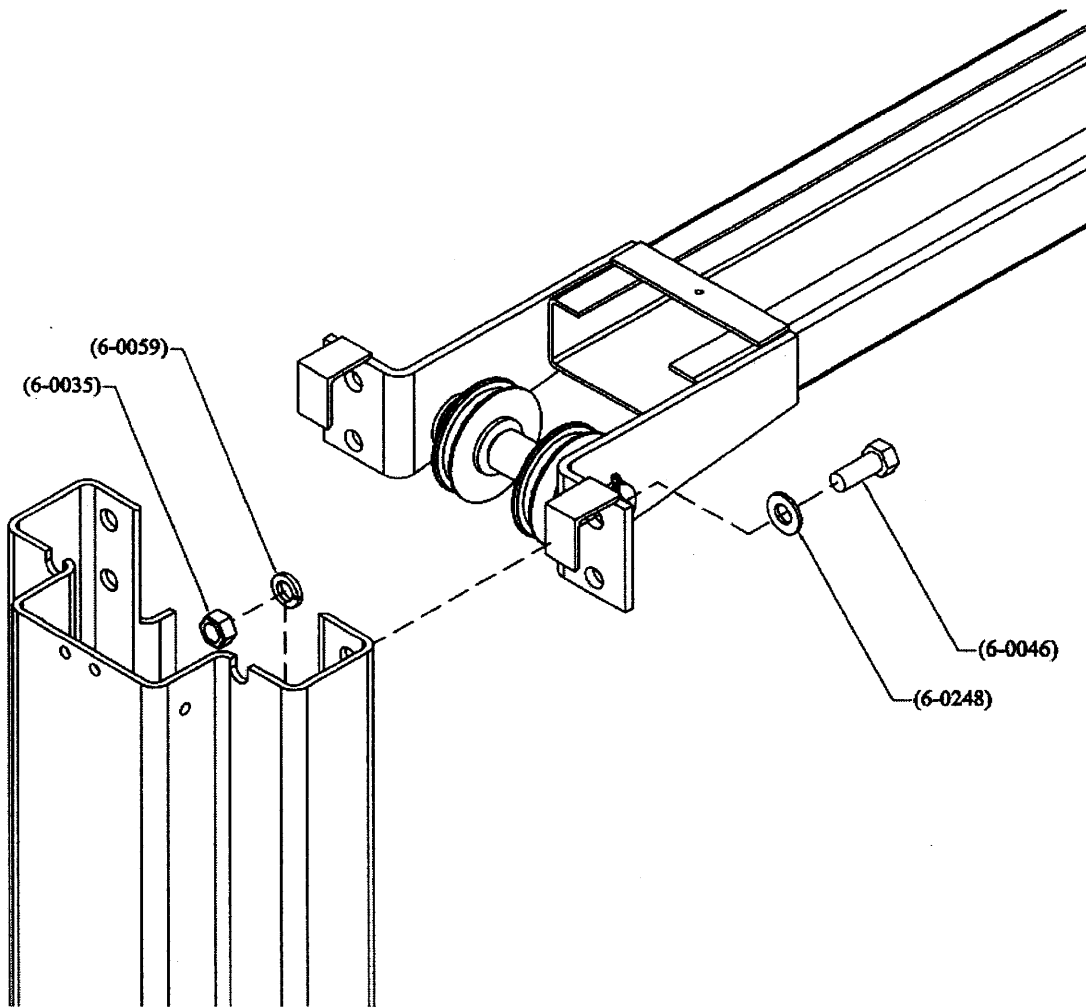
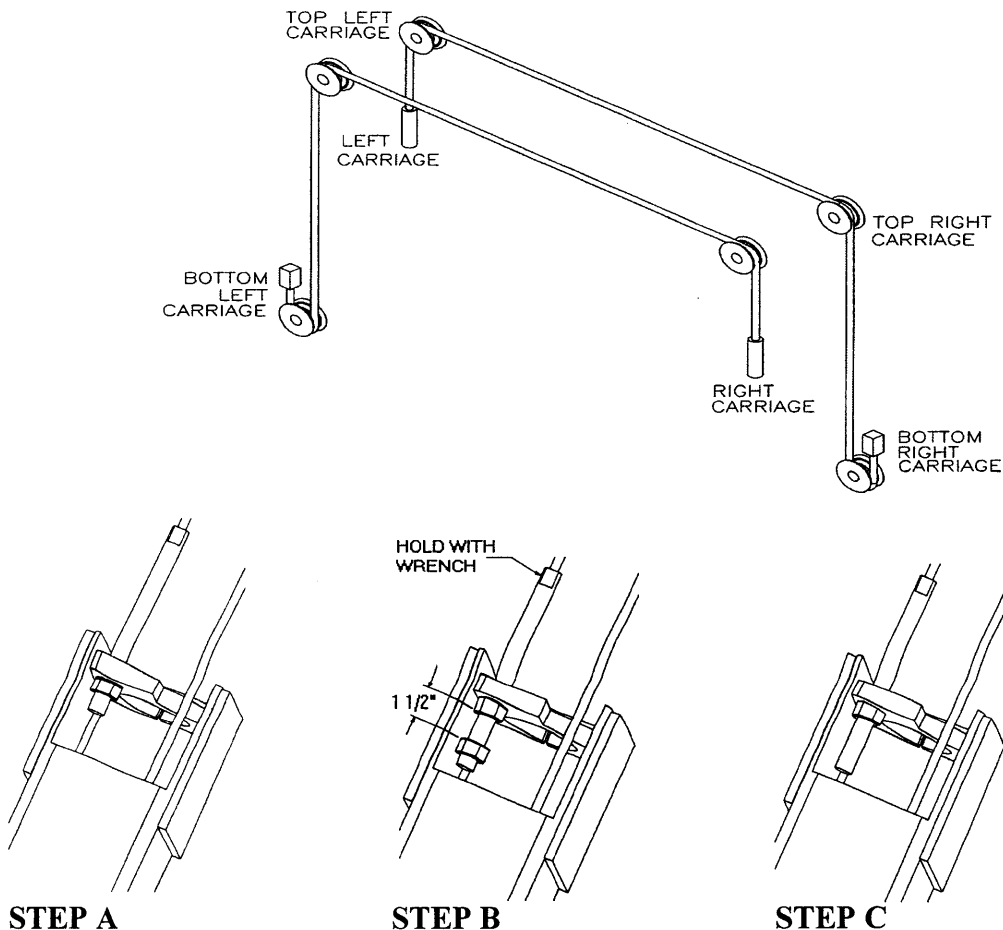

**Figure 5 – Crossmember Assembly**

## 5.6 ROUTING OF EQUALIZATION CABLE

Use **Figure 6** to route the equalization cables.

1. Remove the carriage covers and manually lift the carriages to the first safety latch.
2. Remove the  $\frac{1}{2}$ "-13 UNC nylon locknuts off the equalization cables and retain for use later.
3. Route the equalization cables as shown in Figure 6. Using the first cable, insert the shorter threaded stud up through the  $\frac{9}{16}$ " diameter hole in the bottom of the carriage and feed it up through the opening in the top of the carriage. Run the nylon locknut onto the shorter stud so that  $\frac{1}{2}$ " of threads extend past the top of the locknut and pull the cable back into the carriage. Route the opposite end of the cable around the sheave at the base of the column and up around the sheave at the top of the column. Run the cable across the crossmember and around the sheave at the top of the other column. Insert the longer threaded stud into the  $\frac{9}{16}$ " diameter hole in the top of the carriage.
4. Use a wrench to hold the top of the threaded stud to prevent it from rotating. Tighten the locknut onto the longer threaded stud enough to remove all visible cable slack. Repeat steps 2 to 4 for the other equalizing cable (**Step A**).
5. Using two wrenches, tighten the locknut at the top of the carriage approximately  $1\frac{1}{2}$ " (**Step B**) past the point where visible cable slack has been removed. Repeat for the other cable.

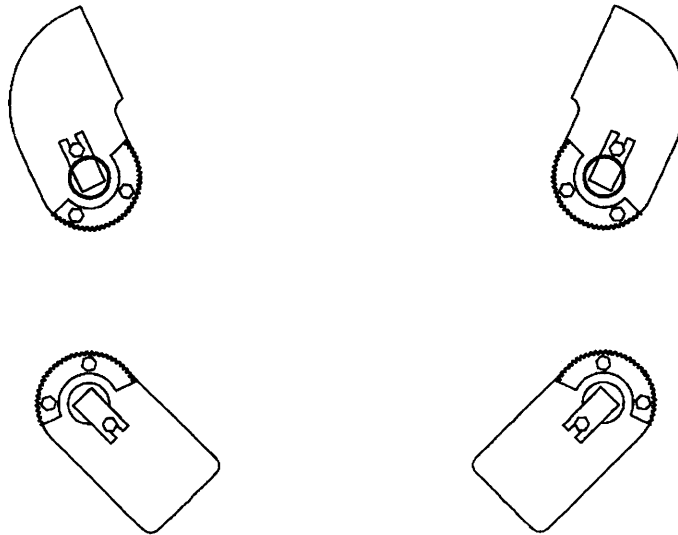

**Figure 6 – Equalization Cables**

## 5.7 ARM INSTALLATION

1. Remove the four (4) 5/16"-18UNC x 3/4"LG. hex head bolts that are holding the arm pins to the arm. Install the arms on the carriages.
2. Grease and insert arm pins. Align the notch on each arm pin with the tapped hole on the arm, and using the 5/16"-18UNC x 3/4"LG. hex head bolt removed in previous step, reinstall and tighten securely.
3. Using two (2) 5/16"-18UNC x 1 1/4" LG. hex head bolts and two (2) 5/16" flatwashers, attach each arm lock gear as shown in **Figure 7**.

FRONT



REAR

**Figure 7 – Arm Installation**

## 5.8 ARM LOCKS INSTALLATION

Using two (2) 3/8"-16UNC x 1" LG. socket head cap screws, and two (2) 3/8" ID lockwashers, install the arm lock assemblies as shown in **Figure 8**. Before tightening completely, make sure that the arm lock has full contact with the arm lock gear by pushing it firmly against the arm.

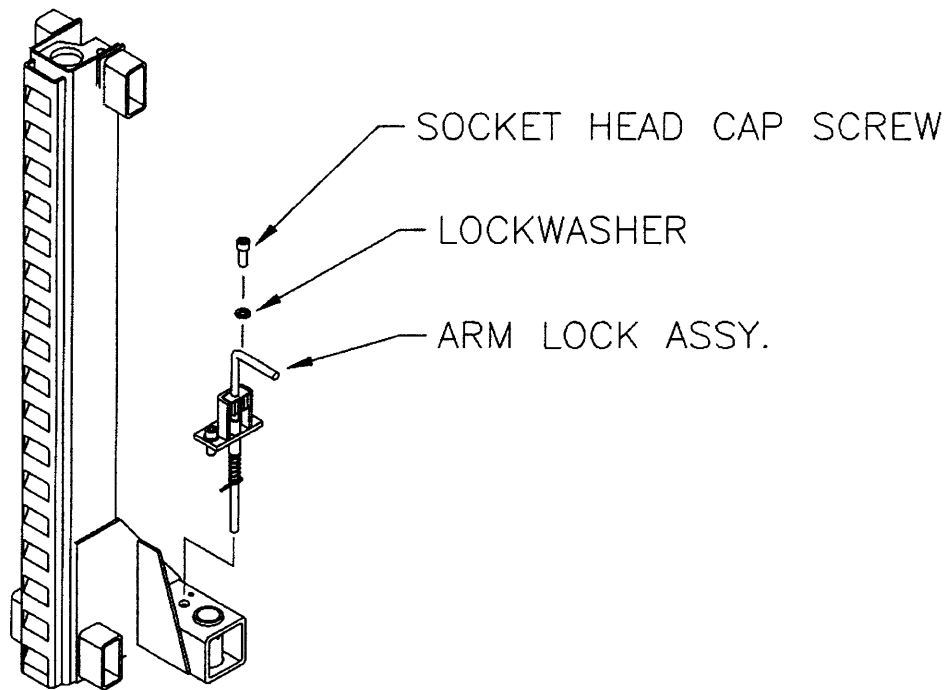
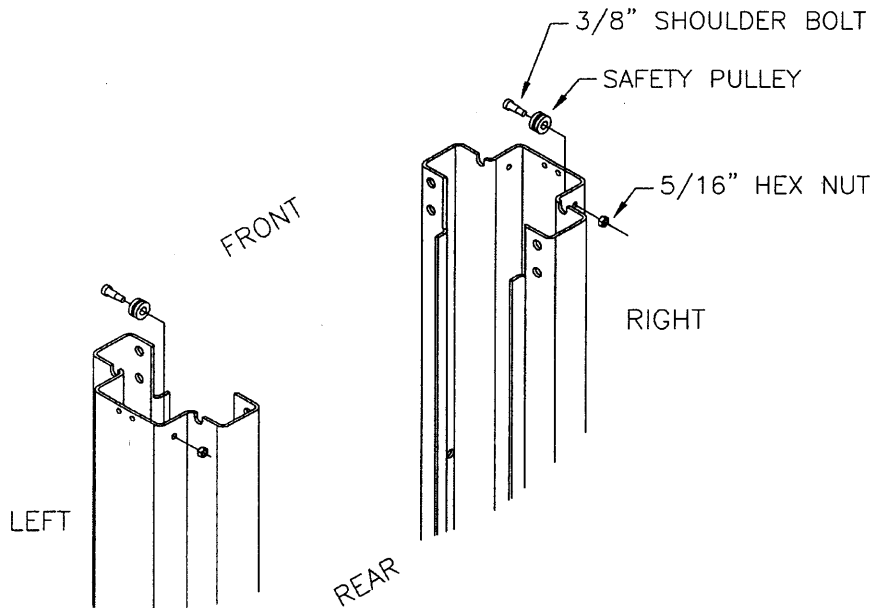

**Figure 8 – Arm Lock Installation**

## 5.9 SAFETY RELEASE CABLE ROUTING AND ADJUSTMENT

**The mechanical safety automatically engages. To release the mechanical safety, you must first raise the lift approximately 2", then pull the safety release lever down. This disengages the power side safety dog and activates the safety cable to release the slave side safety dog.**

1. Install the safety pulley on each tower as shown in **Figure 9**. Attach the safety pulley to the tower using the 3/8" x 5/8" LG. shoulder bolt, 5/16" lockwasher and 5/16" hex nut.



**Figure 9 - Safety Release Pulley Installation**

2. Refer to **Figure 10** for safety release cable routing. The end of the cable that has a collar attaches to the slave side tower. The free end is fixed to the power side tower using two (2) wire rope clips.
3. Install the safety release handle onto the power side safety dog
4. Start routing the safety release cable from the slave side of crossmember. Feed the cable over the small pulley, then guide the cable down along the inside of the slave side tower. Pull the cable out through the opening in the back of the tower near the safety dog.
5. Guide the cable up under the large pulley towards the end of the safety dog. Remove the 3/8" x 1 1/2" shoulder bolt from the safety dog. Feed the shoulder bolt through the collar of the safety release cable and then replace the shoulder bolt securely to the safety dog.
6. Repeat step 2 for the power side tower.

7. Guide the cable up under the large pulley and then over the small pulley towards the safety dog as shown in Figure 10. Wrap the cable around the thimble (attached to the safety dog with a 3/8" x 1 1/2" lg. shoulder bolt) and then clamp it using two (2) wire rope clips. Do not tighten fully at this stage.
8. Adjust the cable length so that both safety dogs travel from full engagement position to full release position when the safety release handle is pulled. **Tighten both wire rope clips firmly when adjustment is completed.**

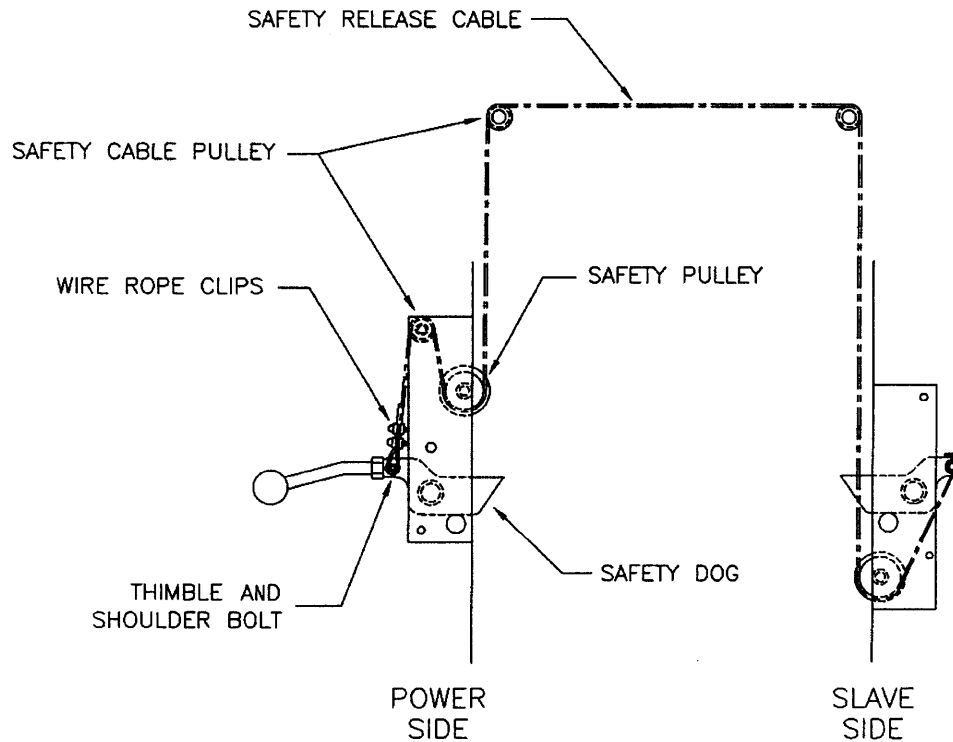

**Figure 10 – Safety Cable Release Routing and Adjustment**

### 5.10 POWER PACK INSTALLATION

1. Remove the **red** plastic cap located at the rear of the power pack, and install the "T" fitting located in the hardware kit.
2. Bolt power pack to the mounting bracket on the power side tower using four (4) 5/16"-18UNC x 1"LG. hex head bolts, four (4) 5/16" ID lock washers, four (4) 5/16" ID flat washers and four (4) 5/16"-18UNC hex nuts. Do not tighten.
3. Remove the filler cap from the powerpack and fill the reservoir with approximately 4.5 Gal. (18L) of ISO32 hydraulic oil (10 wt. hydraulic oil). Remove breather screw when filling and replace when full.
4. A **certified electrician** must connect the 230Volt/1Ph power to the motor. The electrical diagram is provided, refer to **Figure 12**.

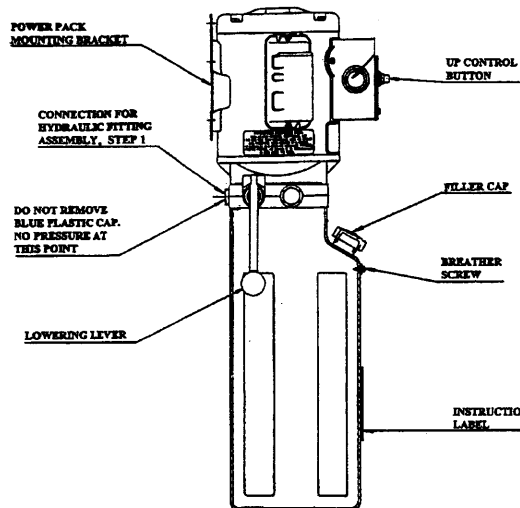

**Figure 11 – Powerpack Details**

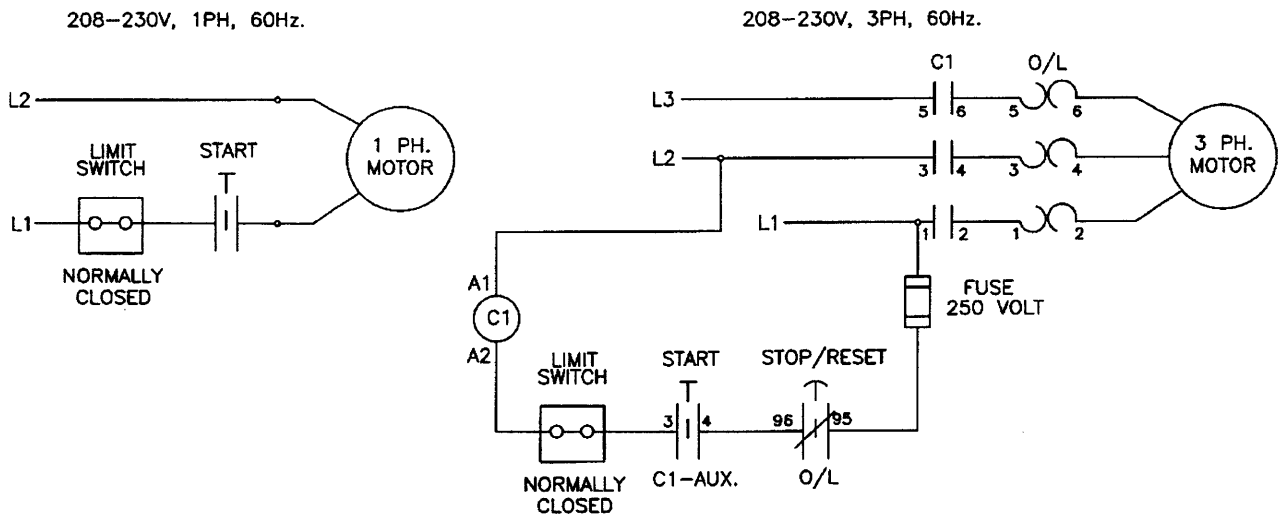

**Figure 12 – Electrical Diagram**

## 5.11 HYDRAULIC SYSTEM INSTALLATION

### REFER TO HYDRAULIC PARTS LIST

1. Connect the 45° end of the long hose to the “T” fitting on the powerpack.
2. Connect the 45° end of the short hose to the other end of the “T” fitting.
3. Remove the plastic cap from the bottom of the power side cylinder and connect the 90° end of the short hose to the cylinder.
4. Loop the hydraulic hose up the power side tower, across the overhead and down the slave side tower. Place rubber grommets (item 68 in the lift assembly) between the tower and the hose at the top of each tower.

5. Remove the plastic cap from the bottom of the slave side cylinder and connect the 90° end of the long hose to the cylinder.
6. The long hydraulic hose must be fixed to the towers using six (6) hose clamps. Screw the hose clamps into the weld nuts on the towers using 1/4"-20UNC x 3/8"lg. round head screws.
7. The long hydraulic hose must be fixed to the crossmember using two (2) hose clamps. Screw the hose clamps into the crossmember using #10 x 3/8" lg. self threading screws.

### 5.12 HYDRAULIC SYSTEM BLEEDING

1. Crack the caps located at the top of both cylinders.
2. Power up 2"-3". You should hear air escaping around the caps. Repeat 3 - 4 times or until only oil is coming out of the caps.
3. Tighten the caps and lower the lift.

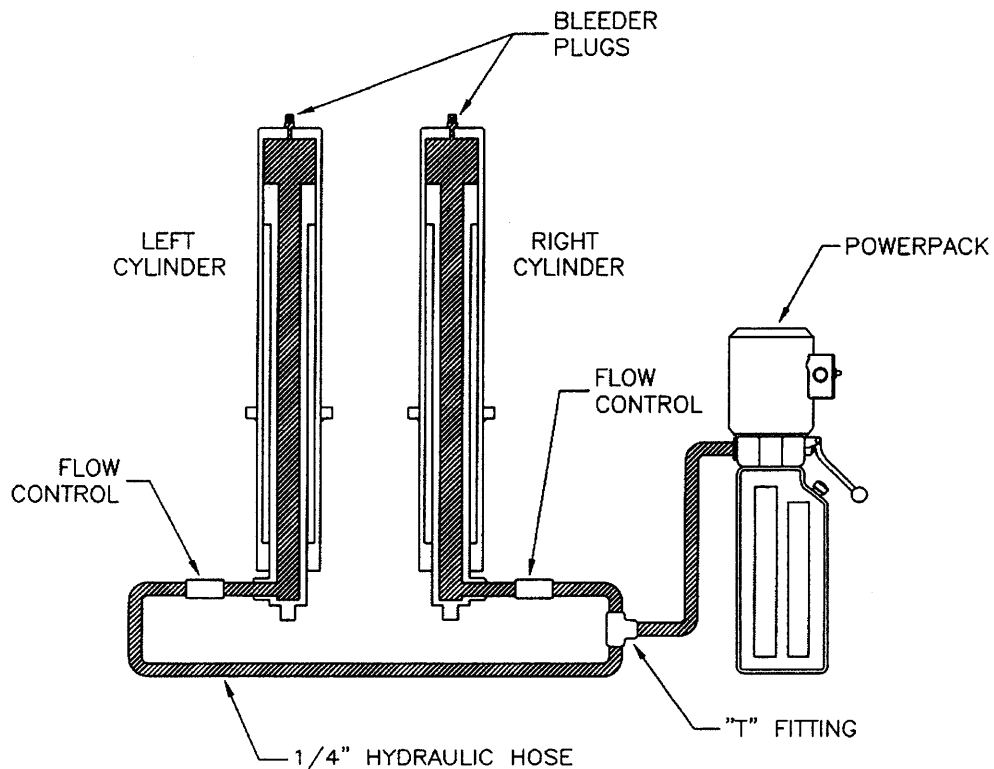

**Figure 13 – Hydraulic Schematic**



## 5.13 TOWER POSITIONING AND ANCHORING

**WARNING!** Failure to follow these instructions may cause an unsafe operating condition.

**WARNING!** Before proceeding with installation, review Section 4: Installation & Tools.

1. Using a 4ft. level on top of the crossmember, determine which column is higher. Refer to **Figure 14**.
2. Using a 2ft. level on the sides of the high column, ensure that the column is level in the vertical position (**Figure 15**). Use shims under the column baseplate to hold the column level. Ensure that the base plate is completely supported by shims where it does not contact the floor (**Figure 16**).

**WARNING!** Do not use more than  $\frac{1}{2}$ " (13mm) of shims. Anchor bolts supplied allow for a maximum of  $\frac{1}{2}$ " (13mm) of shim. If more than  $\frac{1}{2}$ " (13mm) of shims are required, **DO NOT** proceed with installation and contact Product Manufacturer / Supplier for further details.

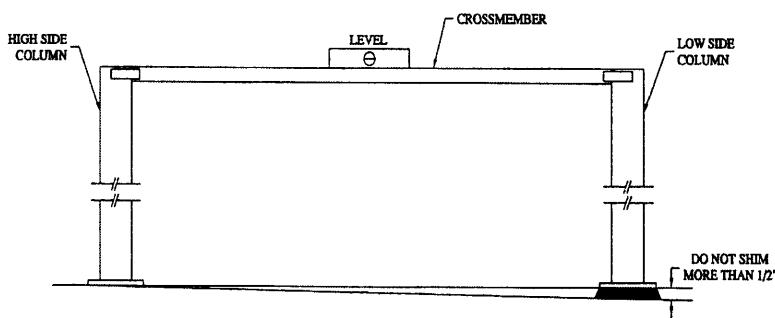

**Figure 14**

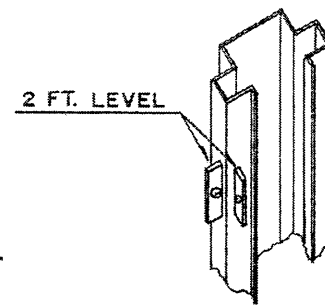

**Figure 15**

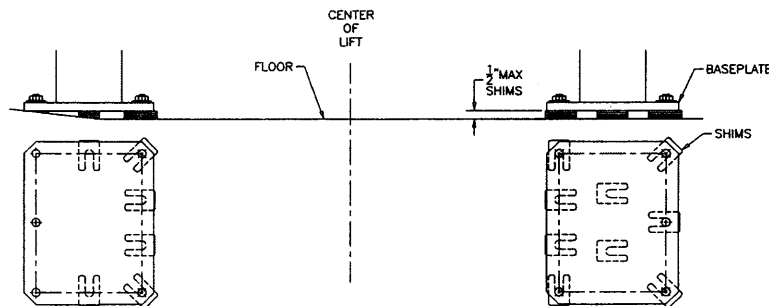

**Figure 16 - Shims**

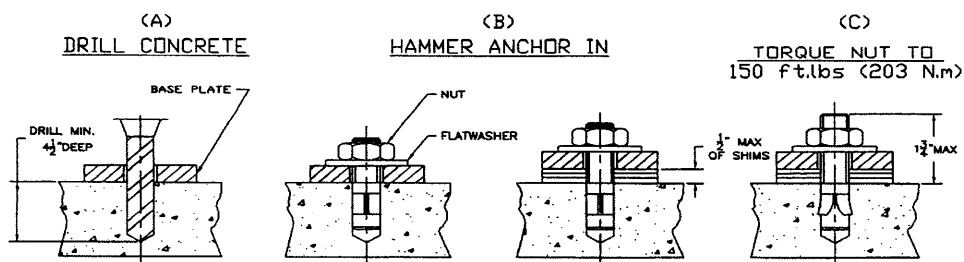

**Figure 17 - Anchor Bolts**

3. Refer to Bay Layout (**Figure 3**) to ensure that the column is still in the proper position. Using a rotary hammer drill with a 3/4" masonry drill bit, drill holes in the floor on the high side column using the tower baseplate as a template. Make sure that the 3/4" masonry drill is in good condition ( ).
4. Carefully clean out drilling dust from the anchor holes. Hammer in the anchor bolts (**Figure 17**). Hand tighten all anchor bolts.
5. Reconfirm that the column is level front to rear and side to side (**Figure 15**). Add or remove shims as required.
6. Torque all anchor bolts to 150 ft-lbs. (203 Nm), continually checking that the column is level as you proceed. If anchor bolts do not tighten to 150 ft-lbs. OR project more than 1 3/4" above the concrete surface (**figure 17**), the concrete MUST be replaced by an appropriate concrete pad. (*Consult Product Manufacturer / Supplier for further details*).

#### **5.14 SHIMMING OF THE REMAINING TOWER**

1. Using a 4ft. level on top of the crossmember (**Figure 14**) and a 2ft. level on the low side column (**Figure 15**), shim underneath the baseplate until the crossmember and column are level. Ensure that the baseplate is completely supported by shims where it does not contact the floor (**Figure 16**).

**WARNING!** *Do not use more than 1/2" (13mm) of shims. Anchor bolts supplied allow for a maximum of 1/2" (13mm) of shim. If more than 1/2" (13mm) of shims are required, DO NOT proceed with installation and contact Product Manufacturer / Supplier for further details.*

2. Refer to Bay Layout (**Figure 3**) to ensure that the column is still in the proper position. Using a rotary hammer drill with a 3/4" masonry drill bit, drill holes in the floor on the low side column using the tower baseplate as a template. Make sure that the 3/4" masonry drill is in good condition (**Figure 17**).
3. Carefully clean out drilling dust from the anchor holes. Hammer in the anchor bolts (**Figure 17**). Hand tighten all anchor bolts.
4. Reconfirm that the column is level front to rear and side to side (**Figure 15**). Add or remove shims as required.
5. Torque all anchor bolts to 150 ft-lbs. (203 Nm), continually checking that the crossmember and column are level as you proceed. If anchor bolts do not tighten to 150 ft-lbs. OR project more than 1 3/4" above the concrete surface (**Figure 17**), the concrete MUST be replaced by an appropriate concrete pad. (*Consult Product Manufacturer / Supplier for further details*).
6. Verify that the entire lift is level both horizontally and vertically to ensure optimum lifting performance. **NOTE: Perform a monthly inspection and torque all anchor bolts to 150 ft-lbs. (203 Nm).**

## **6 LIFT MAINTENANCE GUIDLINES**

### **6.1 SAFETY INSTRUCTIONS**

Read operating and safety manuals before using any lift  
Do not operate a lift that has been damaged or is in disrepair  
Proper inspection and maintenance is necessary for safe operation

### **6.2 PERIODIC MAINTENANCE**

#### **DAILY:**

1. Check all hydraulic lines and fittings for pinch points , damage , cracks or leaks
2. Check all electrical wiring for pinch points , cracks or damage
3. Check all moving parts for uneven or excessive wear
4. Repair or replace all damaged , defective , worn or broken components immediately
5. Check the telescopic arms for movement. Clean any grease or oil from the lifting adapters
6. Raise and lower the lift at the beginning of each shift, without a vehicle on, to verify the lift is leveled and operating properly.

#### **WEEKLY:**

1. Check and adjust hydraulic level

#### **EVERY TWO MONTHS:**

1. Clean and re-grease slide block channels inside of both columns
2. Grease arm pins
3. Lubricate safety dogs and check safety release cable adjustment
4. Check arm restraints and lubricate
5. Check anchor bolts and re-torque if required

#### **EVERY FOUR MONTHS:**

1. Dismantle and clean inner arms
2. Lubricate cable pulleys
3. Check equalizing cable adjustment

#### **EVERY YEAR:**

1. Inspect lift as per Automotive Lift Operation, Inspection and Maintenance (ALOIM)

#### **EVERY TWO YEARS:**

1. Change hydraulic fluid

**LUBRICATION:**

- Where grease is required > multi-purpose lithium grease
- Where lubricating oil is required > multi-purpose SAE 30 lubricating oil
- Where hydraulic oil is required > ISO 32 10W - non detergent hydraulic oil

**NOTE: If lift locks while in the fully raised position this will indicate that the hydraulic system has not been inspected or maintained as recommended. This is a safety back-up system. If you are unclear call your local representative immediately.**

**7 SAFETY AWARENESS  
- AUTOMOTIVE LIFT INSTITUTE (ALI)**

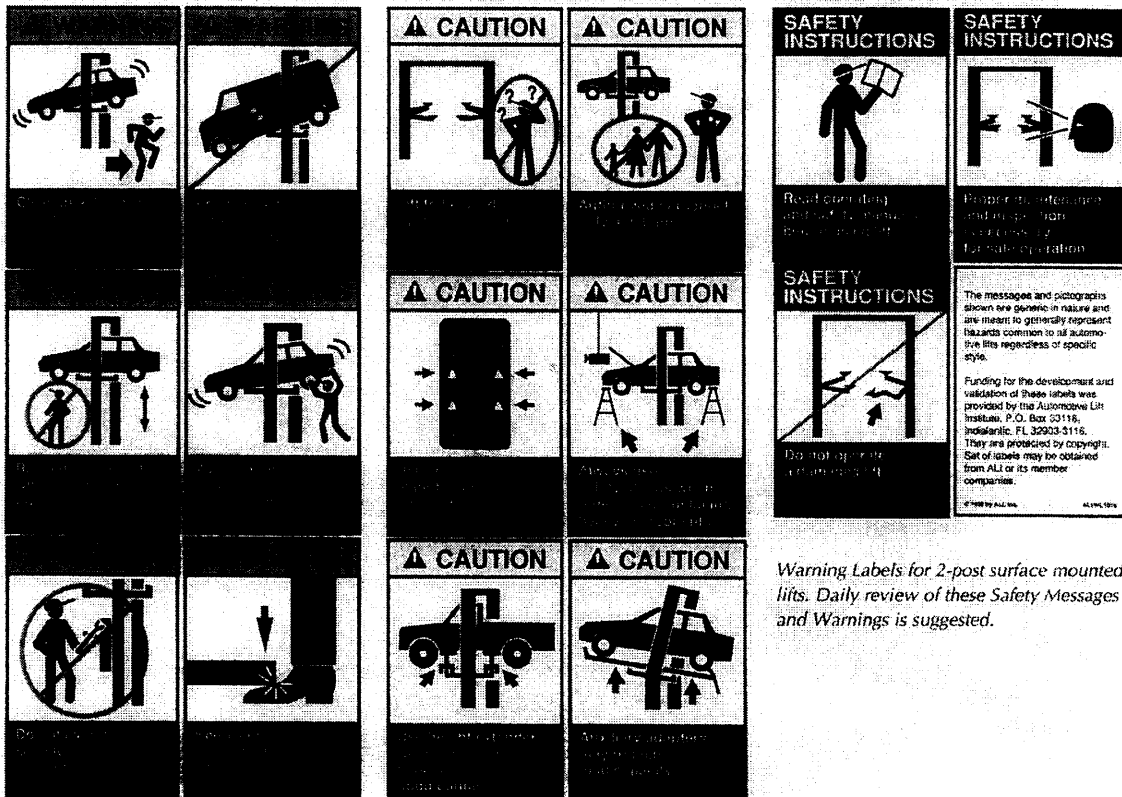

*Warning Labels for 2-post surface mounted lifts. Daily review of these Safety Messages and Warnings is suggested.*

# 8 PARTS MANUAL

## 8.1 LIFT ASSEMBLY

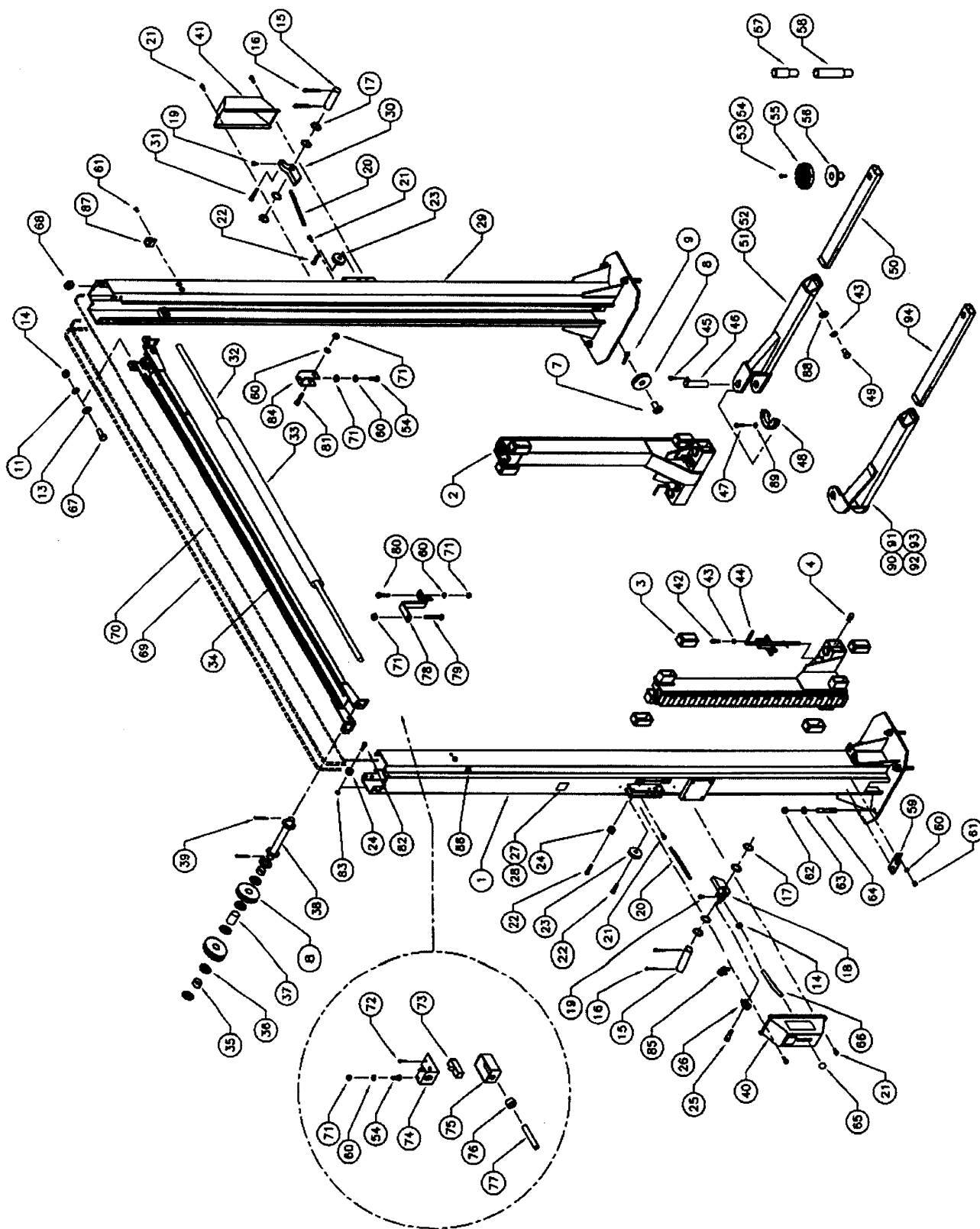

## 8.2 LIFT ASSEMBLY PARTS LIST

ITEM	QTY	DESCRIPTION	PART #
1	1	TOWER WELDMENT, POWER SIDE	4-1010
2	2	CARRIAGE WELDMENT	4-0766
3	8	GLIDE BEARING	2-0772
4	4	GREASE NIPPLE	6-0000
7	2	PIN, CABLE EQUALIZATION	1-1887
8	6	2-POST PULLEY	1-1898
9	2	HITCH PIN, 1/8" DIA	6-1841
11	8	LOCKWASHER, 1/2"ID	6-0059
13	8	FLAT WASHER, 1/2"ID SAE	6-0248
14	13	HEX NUT, 1/2"-13UNC	6-0035
15	2	SAFETY PIN	1-0938
16	4	COTTER PIN, 1/8"DIA. x 1"LG.	6-0267
17	8	FLAT WASHER, 5/164"ID x 1"OD x 1/16"THK.	6-0808
18	1	SAFETY DOG WELDMENT, POWER SIDE	2-1901
19	4	SELF TAPPING SCREW, #10 X 3/8" LG.	6-0169
20	2	SAFETY SPRING	1-1115
21	6	SELF TAPPING SCREW, #12 x 1/2"LG.	6-1134
22	3	SHOULDER BOLT, 3/8"DIA. x 1"LG.	6-0206
23	2	SAFETY PULLEY	1-0415
24	3	SAFETY CABLE PULLEY	1-1116
25	1	SHOULDER BOLT, 3/8" x 1 1/2" LG.	6-0801
26	1	THIMBLE, 5/32"	6-2074
27	1	CAPACITY DECAL	6-1767
28	1	SERIAL PLATE	6-1111
29	1	TOWER WELDMENT, SLAVE SIDE	4-1011
30	1	SAFETY DOG, SLAVE SIDE	2-0872
31	1	SHOULDER BOLT, 3/8"DIA. x 1 1/2"LG.	6-0801
32	1	ACTUATOR BAR	1-1380
33	1	FOAM GUARD	6-1404
34	1	CROSSMEMBER WELDMENT	2-1952
35	4	CROSSMEMBER PULLEY PIPE, 1/2"LG.	1-1623
36	16	FLAT WASHER, 3/4"ID	6-0738
37	2	CROSSMEMBER PULLEY PIPE, 1 3/4"LG.	1-1626
38	2	CROSSMEMBER PULLEY SHAFT	2-1251
39	4	COTTER PIN, 1/8"DIA. x 1 1/2"LG.	6-0978
40	1	SAFETY COVER cw/DECALS, POWER SIDE	0-0204
41	1	SAFETY COVER cw/DECALS, SLAVE SIDE	0-0203
42	8	SOCKET HEAD CAP SCREW, 3/8" X 1" LG.	6-2048
43	12	LOCKWASHER, 3/8" ID	6-0058
44	4	ARM LOCK ASSEMBLY	1-2038
45	4	HEX BOLT, 5/16"-18UNC x 3/4" LG.	6-0423
46	4	ARM PIN	2-1594
47	4	HEX BOLT, 5/16"-18UNC x 1 1/4" LG.	6-2059
48	4	ARM LOCK GEAR	1-2044
49	4	HEX BOLT, 3/8UNCx3/4"LG.	6-0030
50	4	INNER ARM WELDMENT	3-0748

ITEM	QTY	DESCRIPTION	PART #
51	4	OUTER ARM WELDMENT	3-0835
52	4	LOCKING ARM ASSEMBLY cw/ARM LOCK PIN	4-0984-6
53	4	STACK PAD ASSEMBLY	1-2045
54	4	HEX BOLT, 1/4" x 3/4" LG	6-0178
55	4	RUBER PAD	6-2050
56	4	STACK PAD WELDMENT	1-2030
57	4	STACK PAD ADAPTER 3"	1-1993
58	4	STACK PAD ADAPTER 6"	2-1580
59	2	STACK PAD ADAPTER HOLDER	1-2012
60	10	LOCKWASHER, 1/4" ID	6-0056
61	10	ROUND HEAD SCREW, 1/4"-20UNC x 3/8" LG.	6-1353
62	10	HEX NUT, 3/4"-10UNC	6-0737
63	10	FLAT WASHER, 3/4"ID	6-0738
64	10	WEDGE ANCHOR, 3/4"-10UNC x 5 1/2"LG.	6-1379
65	1	PLASTIC KNOB	6-1135
66	1	SAFETY RELEASE HANDLE	1-1113
67	8	HEX BOLT, 1/2"-13UNC x 1 1/4" LG.	6-0046
68	3	RUBBER GROMMET	6-1507
69	2	EQUALIZING CABLE	1-1786
70	1	SAFETY RELEASE CABLE	1-2058
71	7	HEX HD. NUT 1/4"NC	6-0032
72	2	6/32 SCREW (ELECTRICAL BOX)	6-1466
73	1	MICROSWITCH	6-0916
74	1	LIMIT SWITCH MTG. BRACKET	2-1143
75	1	ELECTRICAL UTILITY BOX	6-1403
76	1	CABLE CONNECTOR	6-1133
77	1	ELEC. CABLE 12/3 x 117"LG.	6-1173
78	1	ACTUATOR EXTENSION	1-1379
79	1	HEX HD. BOLT 1/4"NC x 2"LG.	6-0741
80	2	HEX HD. BOLT 1/4"NC x 1 1/4"LG.	6-0027
81	1	HEX HD. BOLT 1/4"NC x 1 1/2"LG.	6-0205
82	2	SHOULDER BOLT, 3/8"DIA. x 5/8"LG.	6-0069
83	2	HEX NUT, 5/16"-18UNC	6-0294
84	1	ACTUATOR MTG. BRACKET	1-1378
85	2	WIRE ROPE CLIP, 1/16"	6-2060
86	3	ELECTRICAL CABLE CLIP, 5/8" ID	6-1759
87	6	TUBE CLAMP, 1/2"	6-0536
88	4	FLATWASHER, 3/8"ID SAE	6-0062
89	8	FLATWASHER, 5/16"ID	6-0295
90	1	OUTER ARM WELDMENT F.R.	3-0863
91	1	OUTER ARM WELDMENT F.L.	3-0862
92	1	LOCKING ARM ASSEMBLY C/W ARM LOCK PIN F.R.	4-1023-6
93	1	LOCKING ARM ASSEMBLY C/W ARM LOCK PIN F.L.	4-1022-6
94	2	INNER ARM WELDMENT	3-0742

### 8.3 HYDRAULIC SYSTEM

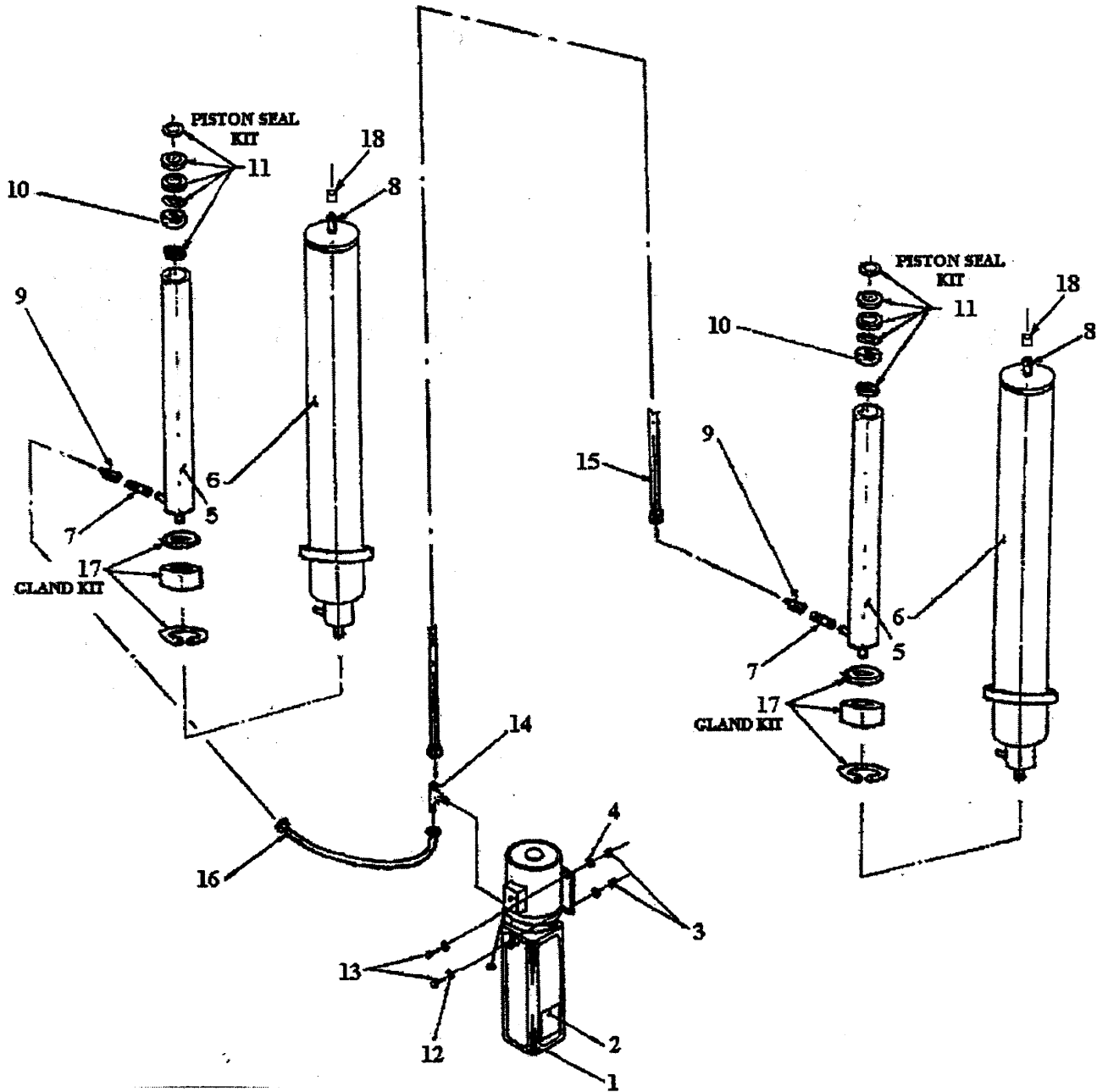



## 8.4 HYDRAULIC SYSTEM PARTS LIST

ITEM	QTY	DESCRIPTION	PART #
1	1	POWER PACK, 208-230V, 1PH	6-2055
		POWER PACK, 208-230V, 3PH	6-2665
2	1	"LIFT OPERATION" DECAL	6-1639
3	4	HEX NUT, 5/16"-18UNC	6-0294
4	4	LOCK WASHER, 5/16" I.D.	6-0674
5	2	PISTON ROD 1 1/4" O.D. x 1/4" W x 72 11/16 LG.	1-1469
6	2	CYLINDER TUBE MACHINED	1-1465
7	2	MALE NIPPLE, 1/4" NPT	6-2059
8	2	1/8" NPT TO 1/4" JIC	6-0280
9	2	FLOW CONTROL	6-1510
10	2	PISTON	1-1467
11	2	PISTON SEAL KIT	0-0337
12	4	FLAT WASHER, 5/16" I.D.	6-0295
13	4	HEX BOLT, 5/16"-18UNC x 1" LG.	6-0293
14	1	BRANCH TEE	6-1506
15	1	HYDRAULIC HOSE (LONG)	1-2040
16	1	HYDRAULIC HOSE (SHORT)	2-1230
17	2	GLAND KIT	0-0338
18	2	1/4" JIC CAP	6-1884
	*	CYLINDER ASSEMBLY (INCL. FLOW CONTROL)	3-0621
		<i>3 PH POWERPACK INCLUDES THE FOLLOWING (NOT SHOWN)</i>	
*	1	CONTACTOR BOX (REMOVE JUMPER & WIRE FOR 3PH)	6-1575
*	1	CONTACTOR BRACKET	2-1130
*	1	COVER PLATE	1-1369
*	2	HEX BOLT, 1/4"-NC x 1" LG	6-0008
*	4	LOCKWASHER, 1/4"	6-0056
*	2	HEX NUT, 1/4"-NC	6-0032
*	2	STRAIN RELIEF	6-0094
*	2FT	CABLE, 14/4	8-0287

### 8.5 POWER PACK:

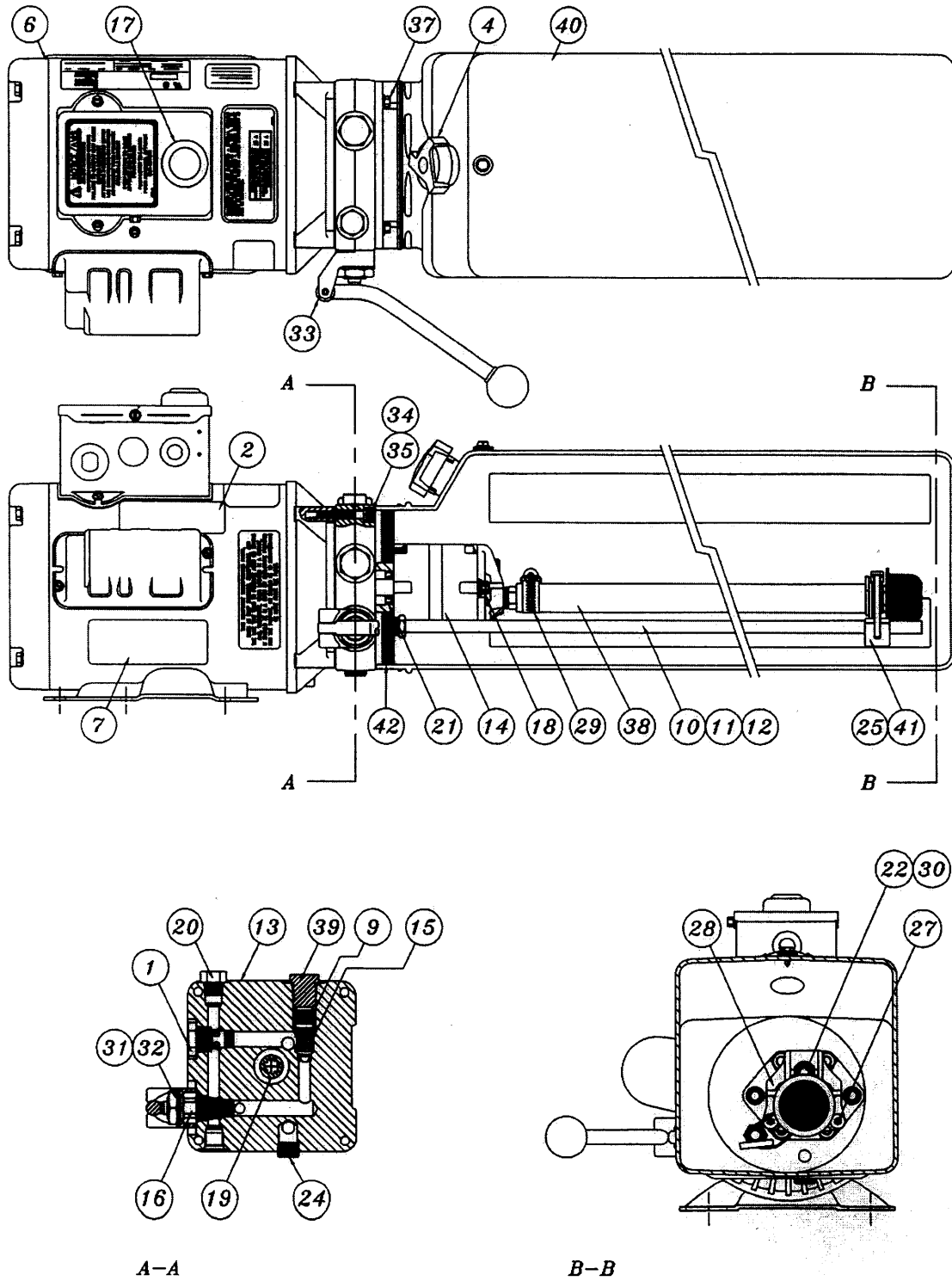

## 8.6 POWER PACK PARTS LIST:

#6-2055 (AB-1381) 208-230V/1PH/60Hz

#6-2665 (AD-1044) 208-230V/3PH/60Hz

ITEM	QTY.	DESCRIPTION	PART #
1	1	VALVE CARTRIDGE CHECK	6-1087
2	1	LABEL INSTALLATION AUTOHOIST	6-2136
4	1	BREATHER CAP & BLADDER	6-1376
6	1	MOTOR AC 208-230V. 2HP/1PH/60Hz, BLK	6-2139
	1	MOTOR AC 208-230V. 2HP/3PH/60Hz, BLK	6-1079
7	1	LABEL WARNING AUTOHOIST	6-2149
9	1	SPRING 0.480" x 0.063" x 0.42" COMP	6-2151
10	1	RETURN HOSE 3/8" OD x 21.5"	6-2152
11	1	COMPRESSION TUBE NUT	6-2153
12	1	COMPRESSION TUBE SLEEVE	6-2154
13	1	ENDHEAD UNIVERSAL AUTOHOIST	6-2155
14	1	PUMPASSY 2.5 CC/REV. SHORT SPLINE	6-1958
15	1	RELIEF ASSEMBLY FIXED 190 BAR	6-1319
16	1	VALVE CARTRIDGE RELEASE MANUAL	6-0880
17	1	WIRING ASSEMBLY AC 1PH FENNER	6-2156
18	2	BOLT 5/16"-24 x 3.00" TORX G8	6-1090
19	1	COUPLING SAE 9T-20/40 1.260"	6-0774
20	1	PLUMBING PLUG 9/16" SAE	6-2157
21	1	SEAL SHAFT 0.500" x 1.00" x 0.25"	6-2158
22	1	WASHER 0.338" x 0.625" x 0.060" STEEL	6-2159
24	1	PLUMBING PLUG 3/8" NPT	6-2161
25	1	PLUMBING MAGNET	6-2162
27	2	SCREW TAPTITE M6 x 1.0 12MM TORX	6-2164
28	1	COVER ASSY SUCTION	6-2165
29	1	PLUMBING CLAMP HOSE ADJ. INLET	6-2166
30	1	BOLT 5/16"-18 x 1.00" SHCS	6-1392
31	1	NUT 3/4"-16 x 1" HEX x 0.250" STEEL	6-2167
32	1	WASHER 3/4" INT. TOOTH LOCK	6-2168
33	1	BRACKET - HANDLE ASSY REL BLACK	6-0776
34	4	BOLT M6 x 1.0 35MM SOC HD	6-2169
35	4	WASHER 1/4" LOCK HI-COLLAR	6-2170
37	4	BOLT #12-24 x 0.50" HEX WSHRHD	6-1091
38	1	PLUMBING ASSY INLET 17.24 (3)	6-0786
39	1	RELIEF VALVE CAP ASSEMBLY	6-1089
40	1	TANK PLASTIC 6.7 OS 22.50" BLK	6-1399
41	1	CABLE TIE 8" LONG WHITE	6-1846
42	1	O-RING 2-348 BUNA	6-0875



# INSTALLATION and OPERATION MANUAL

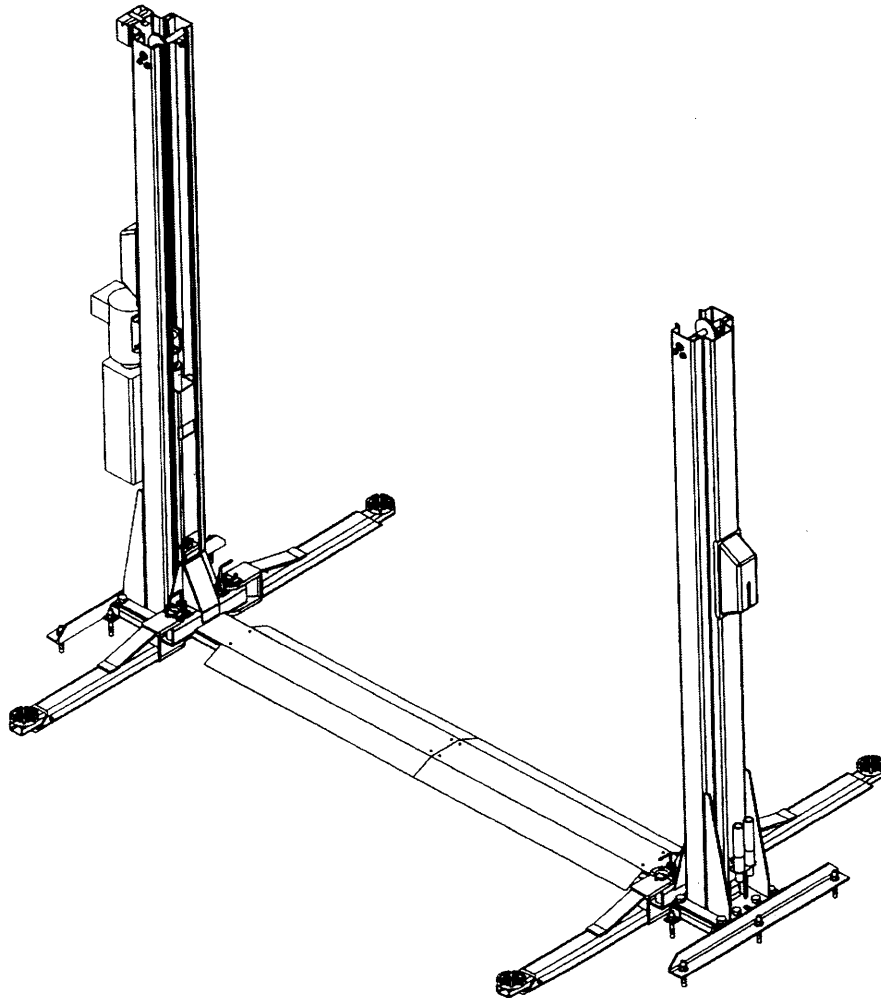

**9,000 LB. BASEPLATE 2 POST**  
**S290L □ □ - R/B/M, 1/3**

**READ and SAVE THIS INSTRUCTION MANUAL**

<b>TABLE OF CONTENTS</b>	<b>PAGE</b>
<b>1 SAFETY AND OPERATING INSTRUCTIONS .....</b>	<b>1</b>
<b>2 SPECIFICATIONS.....</b>	<b>2</b>
<b>3 CONTENTS.....</b>	<b>3</b>
<b>4 INSTALLATION REQUIREMENTS AND TOOLS .....</b>	<b>3</b>
<b>5 INSTALLATION INSTRUCTIONS .....</b>	<b>4</b>
5.1 UNPACKING PROCEDURE .....	4
5.2 BAY LAYOUT.....	5
5.3 TOWER POSITIONING AND SETUP .....	6
5.4 HYDRAULIC CONNECTIONS.....	7
5.5 LIMIT SWITCH INSTALLATION .....	7
5.6 POWERPACK INSTALLATION.....	8
5.7 AIR SAFETY INSTALLATION .....	9
5.8 ROUTING OF EQUALIZATION CABLES .....	9
5.9 ARM INSTALLATION .....	10
5.10 HYDRAULIC SYSTEM BLEEDING .....	11
5.11 TOWER POSITIONING AND ANCHORING .....	12
<b>6 PERIODIC MAINTENANCE.....</b>	<b>13</b>
<b>7 SAFETY AWARENESS - AUTOMOTIVE LIFT INSTITUTE (ALI).....</b>	<b>13</b>
<b>8 PARTS MANUAL .....</b>	<b>14</b>
8.1 LIFT ASSEMBLY.....	14
8.2 LIFT ASSEMBLY PARTS LIST .....	16
8.3 HYDRAULIC SYSTEM .....	18
8.4 HYDRAULIC SYSTEM PARTS LIST .....	19
8.5 AIR SYSTEM.....	20
8.6 AIR SYSTEM PARTS LIST .....	21
8.7 POWER PACK:.....	22
8.8 POWER PACK PARTS LIST:.....	23
8.9 LIFT MAINTENANCE GUIDELINES – CABLE EQUALIZATION .....	24

## 1 SAFETY AND OPERATING INSTRUCTIONS

1. Read all instructions.
2. Inspect lift daily. Do not operate if it malfunctions or problems have been encountered.
3. Never attempt to overload the lift. The manufacturer's rated capacity is shown on the identification label on the power side column. Do not override the operating controls or the warranty will be void.
4. Only trained and authorized personnel should operate the lift. Do not allow customers or bystanders to operate the lift or be in the lift area.
5. Position the lift support pads to contact the vehicle manufacturer's recommended lifting points. Raise the lift until the pads contact the vehicle. Check pads for secure contact with the vehicle, then raise the lift to the desired working height.
6. Some pickup trucks may require an optional truck adapter to clear running boards or other accessories. **NOTE:** Always use all 4 arms to raise and support vehicle.
7. **Caution! Never work under the lift unless the mechanical safety locks are engaged.**
8. Note that the removal or installation of some vehicle parts may cause a critical load shift in the center of gravity and may cause the vehicle to become unstable. Refer to the vehicle manufacturer's service manual for recommended procedures.
9. Always keep the lift area free of obstruction and debris. Grease and oil spills should always be cleaned up immediately.
10. Never raise vehicle with passengers inside.
11. Before lowering check area for any obstructions.
12. Before driving vehicle between the towers, position the arms to the drive-through position to ensure unobstructed clearance. Do not hit or run over arms as this could damage the lift and/or vehicle.
13. Before removing the vehicle from the lift area, position the arms to the drive-through position to prevent damage to the lift and /or vehicle.
14. Care must be taken as burns can occur from touching hot parts.
15. Do not operate equipment with a damaged cord or if the equipment has been dropped or damaged – until a qualified serviceman has examined it.
16. Do not let cord hang over table, bench or counter or come in contact with hot manifolds or moving fan blades.
17. If an extension cord is necessary, a cord with a current rating of two or more than that of the equipment should be used. Cords rated for less current than the equipment may overheat. Care should be taken to arrange the cord so that it will not be tripped over or pulled.
18. Always unplug the equipment from electrical outlet when not in use. Never use the cord to pull the plug from the outlet. Grasp plug and pull to disconnect.

## 2 SPECIFICATIONS

Capacity:  
 Overall Width (incl. powerpack):  
 Width Between Columns:  
 Drive-Thru Width:  
 Overall Height:  
 Baseplate Height:  
 Height to Lowered Lift Pads:  
 Height to Lift Pad (3" Adapter):  
 Height to Lift Pad (6" Adapter):  
 Retracted Arm Length:  
 Extended Arm Length:  
 Maximum Lifting Height (6" Adapter):  
 Lift Time:  
 Power Requirements (Standard):

9000 lbs.	4080 kg
151 3/4"	3855 mm
118 1/2"	3010 mm
109"	2769 mm
120"	3048 mm
2"	51 mm
4"	102 mm
7"	178 mm
10"	254 mm
35 1/4"	895 mm
53 1/2"	1359 mm
78'	1981 mm
45 seconds	
230 Volts AC, 1 Ph., 60Hz.	

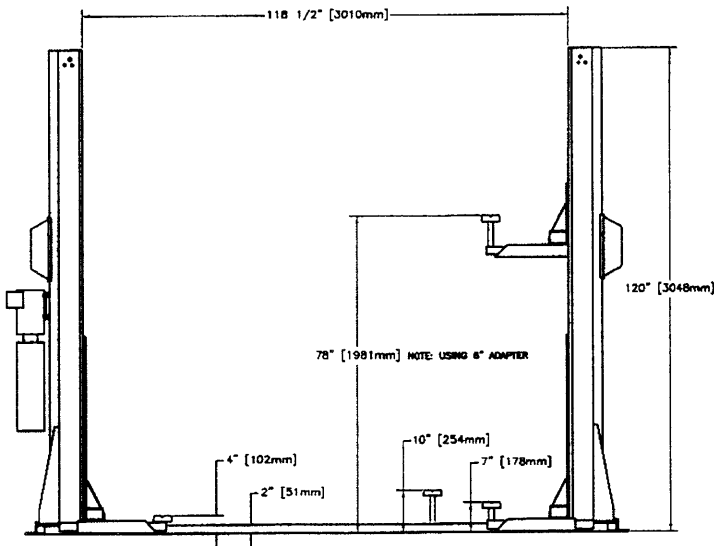

**Figure 1 – Front View**

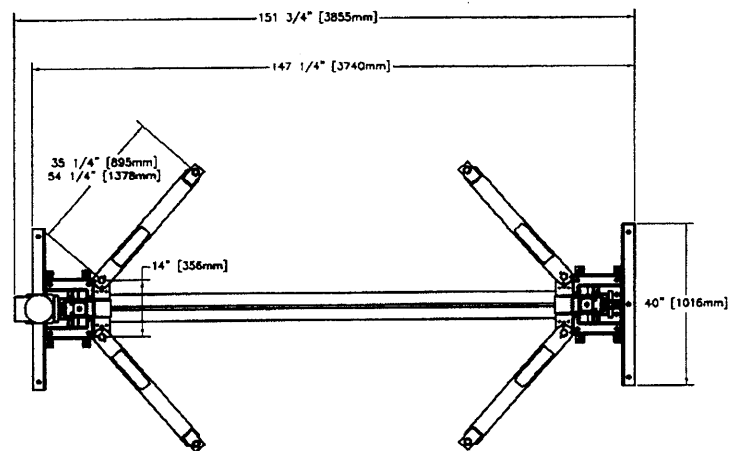

**Figure 2 – Top View**

### 3 CONTENTS

The complete lift is contained in three (3) packages:

1. The towers are packed in a steel frame
2. The baseframe and line covers are packed on a skid
3. The remaining parts are packed in an **accessory box**.

**Tower Components include:**

- 1pc. - Power side tower and carriage assembly
- 1pc. - Slave side tower and carriage assembly

**Baseframe Components include:**

- 1pc. - Baseframe weldment
- 2pc. - Linecover

The accessory box has its own packing slip listing contents.

### 4 INSTALLATION REQUIREMENTS AND TOOLS

**IMPORTANT: It is the user's responsibility to provide a satisfactory installation area for the lift. Lifts should only be installed on level concrete floors with a minimum thickness of five (5) inches or 130 mm. Concrete must have a minimum strength of 4000 psi or 30 MPa and should be aged thirty (30) days prior to installation. Please consult the architect, contractor or engineer if doubt exists as to the strength and feasibility of the floor to enable proper lift installation and operation.**

**It is the user's responsibility to provide all wiring for electrical hook-up prior to installation and to insure that the electrical installation conforms to local building codes. Where required, it is the user's responsibility to provide an electrical isolation switch located in close proximity to the lift that will enable emergency stop capability and isolate electrical power from the lift for any servicing requirements.**

**Tools Required:**

- a. 16ft. Measuring Tape
- b. Chalk Line
- c. Rotary Hammer Drill
- d. 3/4" diameter Masonry Drill Bit
- e. Hammer
- f. SAE Wrenches and Ratchet Set
- g. 2ft. Level
- h. 4ft. Level
- i. Crow Bar
- j. 12ft. Step Ladder
- k. Side Cutters
- l. Screwdrivers
- m. 4" x 4" Wooden Blocks (for unpacking)



## 5 INSTALLATION INSTRUCTIONS

When the lift arrives on site:

- Read the owner's manual and make sure the installation instructions are fully understood.
- Check for any freight damages.
- Check the contents of the accessory and hardware boxes to make sure no parts are missing.
- Gather all the tools listed above.

### 5.1 UNPACKING PROCEDURE

1. **Important!** Place the main structural components on wooden blocks so that the steel shipping frames can be removed.
2. Remove the plastic wrapping.
3. Unbolt the steel shipping frames.
4. Lay each tower on the floor with the carriage side up.
5. Unpack the crossmember and line covers
6. Check the installation area for obstructions. (Lights, Heating Ducts, Ceiling, Floor Drains, etc.)
7. Prepare the bay by selecting the location of the lift relative to the walls. Clear the installation area of all packaging materials to avoid trip hazards. Draw a chalk line on the floor to represent the centerline of the bay then draw a second chalk line at 90° for locating the lift towers. Refer to **Figure 3**.

## 5.2 BAY LAYOUT

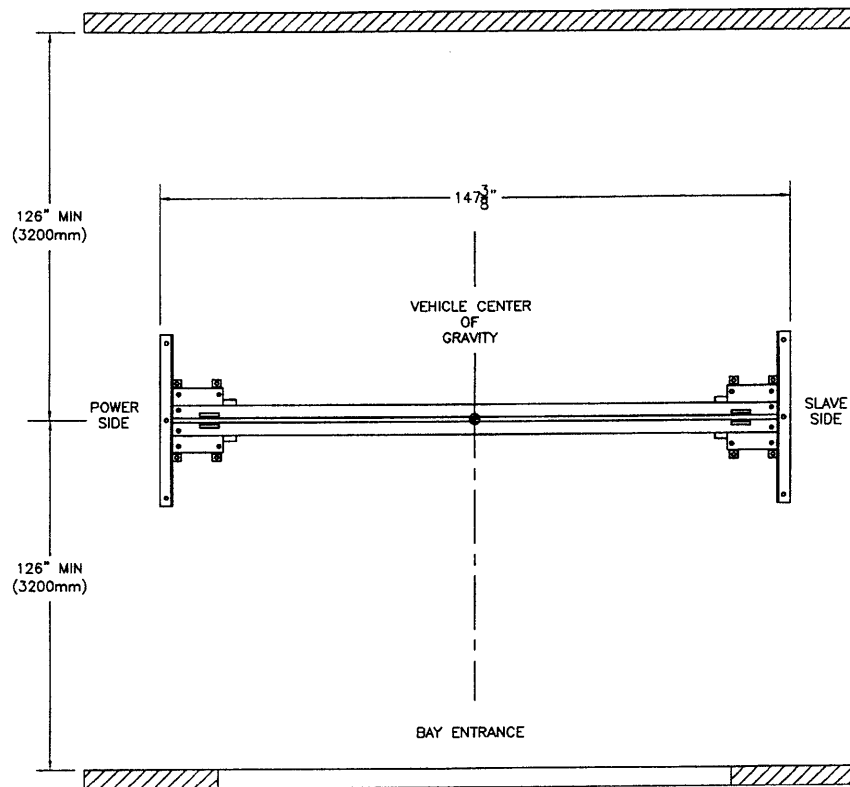
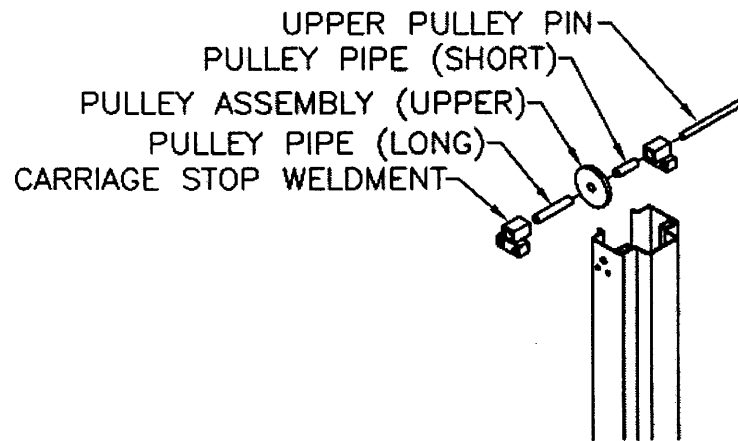

Figure 3 – Bay Layout

### 5.3 TOWER POSITIONING AND SETUP

1. Locate the baseframe weldment as shown in **Figure 3**. Use the shims in the hardware kit to ensure that the base is level in all directions.
2. Locate the power side and slave side towers and position them on the baseframe as shown in **Figure 3**. Note: the power side has a mounting bracket for the powerpack welded to the back of the crossmember.
3. Anchor the towers to the baseplate using the  $\frac{3}{4}$ "-NC hex bolts and  $\frac{3}{4}$ " lockwashers found in the hardware kit. At this point, only screw the bolts in as far as the first few threads. This is important, as some adjustment of the towers may be necessary when making the hydraulic connections.
4. Lift the carriages up and rest them on the first safety.
5. Assemble the upper pulley assemblies using the upper pulley pin, pulley pipe (long – approx 3  $\frac{1}{2}$ " ), pulley pipe (short – approx 1" ), and carriage stop weldments (all items found in the accessory box). When looking at the open front of the tower, the short spacer should always be on the left of the pulley, and the long spacer should be on the right of the pulley. The flatwashers should go on the outside of the tower.



6. Slide the pulley assemblies into the top of the tower and install the carriage stop weldments using the  $\frac{1}{2}$ "-NC x 2  $\frac{1}{4}$ " hex bolts,  $\frac{1}{2}$ " flatwashers,  $\frac{1}{2}$ " lockwashers, and  $\frac{1}{2}$ "-NC hex nuts located in the hardware kit (see figure below)

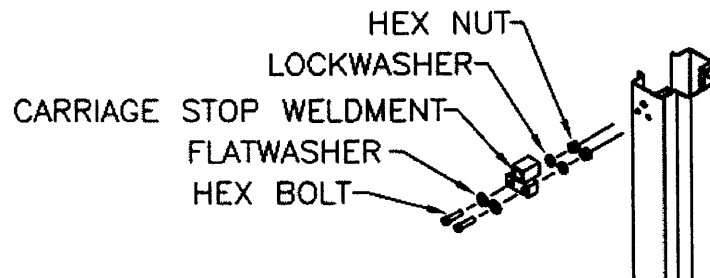

## 5.4 HYDRAULIC CONNECTIONS

NOTE: REFER TO THE HYDRAULICS SYSTEM SHOWN IN THE PARTS LIST.

1. Connect the long leg of the 9 ½” steel hydraulic tube (with the 90 degree bend) in-line to the 3/8” JIC union T. Both items are found in the accessory box.
2. Feed the tube and union T under the driver side tower, in between the crossmember tubes of the baseframe. The short leg at 90 degrees should come out of the opening at the back of the tower. If necessary use electrical tape to keep the cap at the end of the short leg of the tube while feeding the assembly under the tower.
3. Connect the 3/8” JIC union adapter (found in the accessory box) to the short leg of the 9 ½” hydraulic tube. Connect the straight end of the short flex hose (found in the accessory box) to the other end of the 3/8” JIC union adapter.
4. Remove and discard the caps from the flow control at the base of each cylinder.
5. Connect one end of the long flex hose (found in the accessory box) in-line to the 3/8” JIC union T.
6. Use one of the 2 5/8” steel hydraulic tubes to connect the driver side cylinder to the final port on the 3/8” JIC union T.
7. Run the long flex hose to the opposite tower in between the baseframe crossmembers.
8. Connect the 3/8” JIC elbow to the second 2 5/8” hydraulic tube (both items found in the accessory box). Connect the opposite end of the elbow to the free end of the long flex hose. Connect the remaining end of the 2 5/8” steel hydraulic line to the flow control on the passenger side cylinder.

## 5.5 LIMIT SWITCH INSTALLATION

1. Screw the microswitch assembly (located in the accessory box) to the inside of the protective guard on the top of the driver side tower.
2. Install the rocker arm (located in the hardware kit) on the driver side tower using the limit switch pin and two snap rings (located in the hardware kit). Refer to Figure 4
3. Place the electrical cable clips (located in the hardware kit) on the tower to run the electrical line from the microswitch to the powerpack.

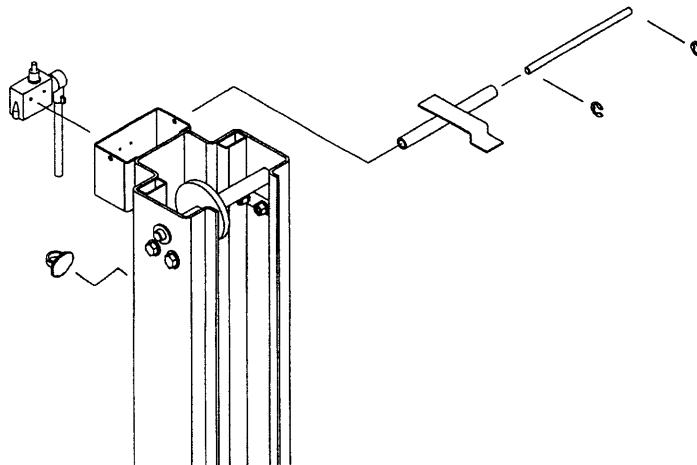
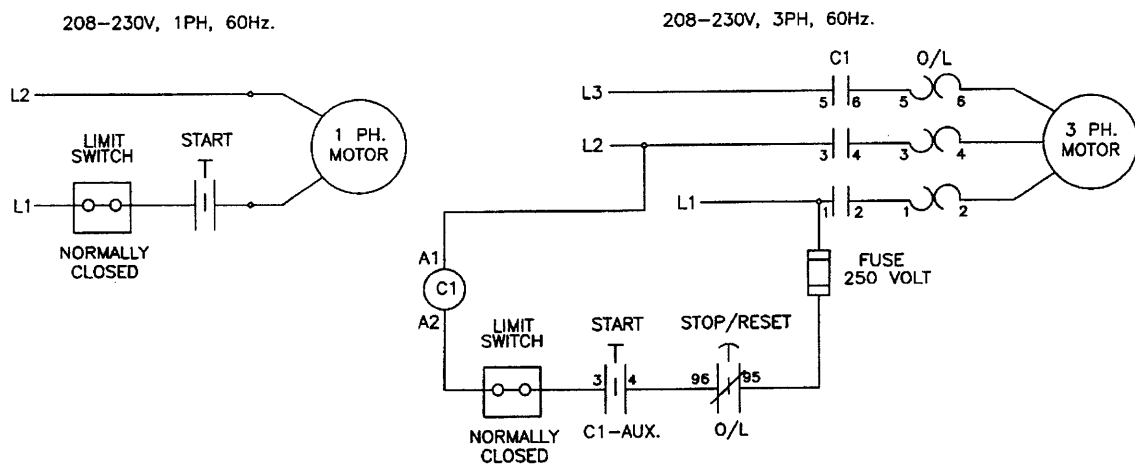

Figure 4 – Limit Switch Installation

## 5.6 POWERPACK INSTALLATION

1. Remove and discard the red plastic cap located at the rear of the power pack, and install the 90 degree elbow (JIC to SAE) located in the hardware kit.
2. Bolt power pack to the mounting bracket on the power side tower using four (4) 5/16"-18UNC x 1"LG. hex head bolts, four (4) 5/16" ID lock washers, four (4) 5/16" ID flat washers and four (4) 5/16"-18UNC hex nuts (found in the hardware kit).
3. Connect the short flex hose to the 90 degree elbow.
4. Fasten the short flex hose to the tower using the hose clamp, 1/4" lockwasher, an 1/4"-NC x 3/8" round head screw (located in the hardware kit).
5. Remove the filler cap from the powerpack and fill the reservoir with approximately 4.5 Gal. (18L) of ISO32 hydraulic oil (10 wt. hydraulic oil). Remove breather screw when filling and replace when full.
6. A **certified electrician** must connect the 230Volt/1Ph power to the motor. The electrical diagram is provided, refer to



7. **Figure 6.**

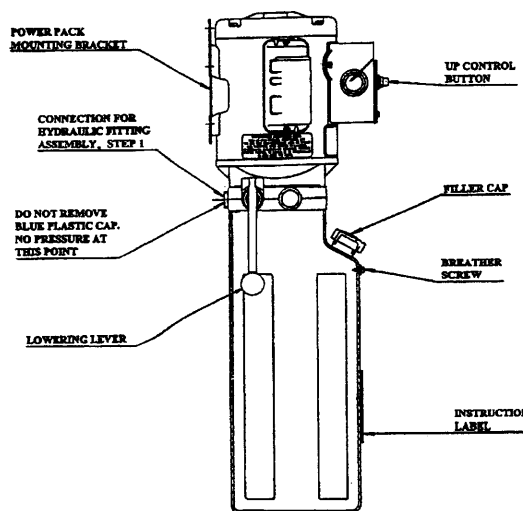

**Figure 5 – Powerpack Details**

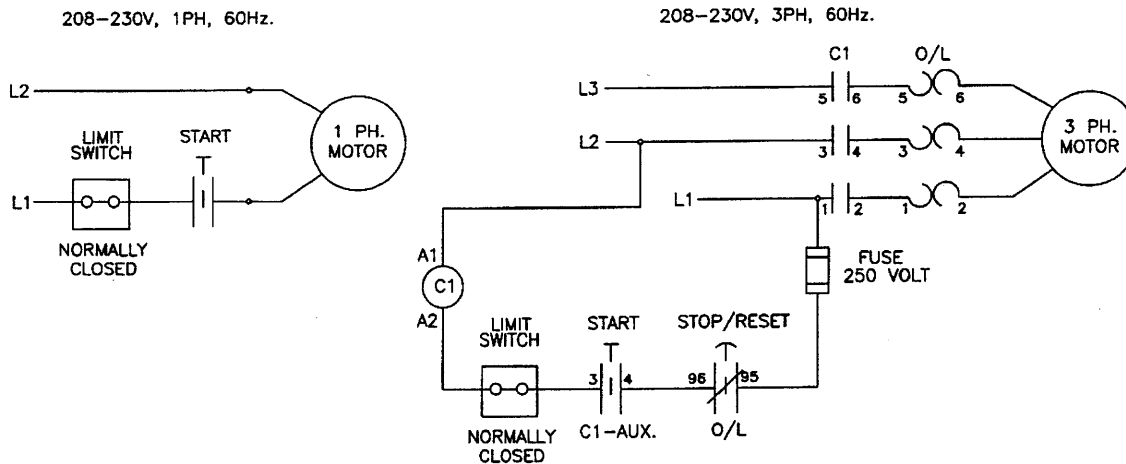

**Figure 6 – Electrical Diagram**

## 5.7 AIR SAFETY INSTALLATION

NOTE: WHEN CUTTING POLYTUBE BE SURE TO CUT THE LINE AT NINETY DEGREES. FAILURE TO DO SO MAY RESULT IN LEAKS IN THE AIR CONNECTIONS.

1. Pull the red pushbutton off the air valve and filter assembly (found in the accessory box) and unscrew the plastic jam nut. Place the assembly on the motor mount bracket and fasten it using the plastic jam nut. Replace the red pushbutton.
2. Cut a short (2" LG) piece of 4mm polytube and connect it to the air valve. Attach the 4mm union T (located in the hardware kit) to the end of the polytube.
3. Attach the rod clevises to the air cylinders (found in the hardware kit).
4. Attach the 90 degree push lock elbows to the air cylinders.
5. Attach the air cylinders to the safety bracket weldments using the 5/16"-NC X 3/4" shoulder bolts found in the hardware kit. These should go through the base of the cylinder.
6. Connect the opposite end of the air cylinders (rod clevises) to the safety dogs using the 5/16"-NC x 1 1/4" shoulder bolts.
7. Run the 4mm polytube through the hole in the R.S. safety cover and connect it to the air cylinder on the passenger side. Attach the R.S. safety cover to the tower.
8. Run the 4mm polytube down the tower and through the cutout in the back of the tower baseplate. Run the polytube between the crossmember tubes to the driver side tower. Feed the polytube under the driver side tower and up through the cutout in the back of the tower. Run the polytube up to the union T at the air valve, cut the air line at this point and connect it to the union T.
9. Run another piece of 4mm polytube through the hole in the L.S. safety cover and connect it to the air cylinder on the driver side tower. Attach the L.S. safety cover to the driver side tower. Run the polytube down to the union T and connect it to the remaining port (Trim excess polytube as required).
10. Connect the shop air supply to the air valve and filter assembly.

## 5.8 ROUTING OF EQUALIZATION CABLES

1. Run the lift up to full stroke and lower the carriages onto the top safety. Note: the carriages may not go up together at this point, but continue to power up until both carriages have reached the top.
2. Run the threaded end of the first equalization cable down the back right side of the driver side carriage and feed it through the cable boss at the bottom of the carriage. Pull the rest of the cable through the carriage so that the button at the end of the cable butts up against the cable boss. Feed the cable through the cutout in the tower baseplate and run it through the hollow structural tube to the opposite side. Fish the threaded end of the cable out of the opening in the opposite tower baseplate. Feed the cable up through the back left hand side of the carriage and let it hang freely over the top of the carriage. Repeat this procedure with the second cable starting at the passenger side tower.
3. Use the  $\frac{3}{4}$ " diameter pins and snap rings located in the hardware kit to attach 2 pulleys to each tower weldment (on the post below the cylinder). Make sure that the cables run freely under the pulleys and that a thrust washer is placed between each pulley and the cylinder post.
4. Take the threaded end of each cable and run it up the tower, over the pulley at the top of the tower, and back down to the carriage. The threaded end should be fed through the cable boss on the top left side of the carriage and the  $\frac{1}{2}$ " locknut should be tightened until all slack has been removed (use vise grips to hold the square portion of the threaded stud).
5. Using the #12 self threading screws (found in the hardware kit), fasten the line covers to the baseplate.

## 5.9 ARM INSTALLATION

1. Raise the lift, press the air safety release and lower the lift to the ground.
2. Remove the arm assemblies from the accessory box and place one arm at each corner of the carriages.
3. Remove the four (4)  $\frac{5}{16}$ "-18UNC x  $\frac{3}{4}$ " LG. hex head bolts that are holding the arm pins to the arm. Install the arms on the carriages.
4. Grease and insert arm pins. Align the notch on each arm pin with the tapped hole on the arm, and using the  $\frac{5}{16}$ "-18UNC x  $\frac{3}{4}$ " LG. hex head bolt removed in previous step, reinstall and tighten securely.
5. Using two (2)  $\frac{5}{16}$ "-18UNC x  $1\frac{1}{4}$ " LG. hex head bolts and two (2)  $\frac{5}{16}$ " flatwashers, attach each arm lock gear as shown in **Figure 7**.

FRONT

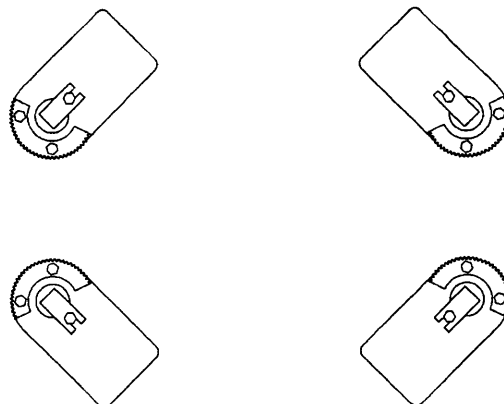

## REAR

### Figure 7 – Arm Installation

6. Using two (2) 3/8"-16UNC x 1" LG. socket head cap screws, and two (2) 3/8" ID lockwashers, install the arm lock assemblies as shown in **Figure 8**. Before tightening completely, make sure that the arm lock has full contact with the arm lock gear by pushing it firmly against the arm.

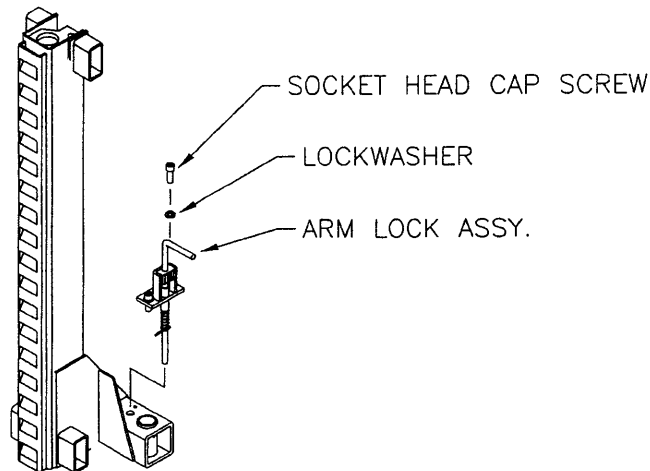

### Figure 8 – Arm Lock Installation

7. Attach the lift pad adapter holders (found in the hardware kit) to the base of each tower (on the back side) using the 1/4" lockwashers, and 1/4"-NC x 3/8" round head screws located in the hardware kit.

## 5.10 HYDRAULIC SYSTEM BLEEDING

1. Run the lift up and down several times to bleed the system.
2. On startup, spray a small amount of lubricating oil into the breather hole at the top of the cylinder. This will help reduce initial friction in the system in case the seals have dried during transport.



## 5.11 TOWER POSITIONING AND ANCHORING

**WARNING!** Failure to follow these instructions may cause an unsafe operating condition.

**WARNING!** Before proceeding with installation, review Section 4: Installation & Tools.

1. Using a 4ft. level on top of the baseplate, shim the base until it is completely level. Ensure that the base plate is completely supported by shims where it does not contact the floor
2. Place 1/16" shims under the bolts at the front of each tower (i.e. to angle the towers outwards). Tighten the 3/4"-NC hex bolts that hold the towers to the baseplate. Using a 4ft. level on the sides of the column, ensure that each column is level front to back. When leveling side to side, the bubble should be at the back of the level because of the shim used to kick the towers outwards.

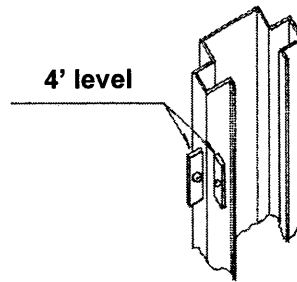

3. Using a rotary hammer drill with a 3/4" masonry drill bit, drill holes in the floor on the high side column using the tower baseplate as a template. Make sure that the 3/4" masonry drill is in good condition (**Figure 9**).
4. Carefully clean out drilling dust from the anchor holes. Hammer in the anchor bolts (**Figure 9**). Hand tighten all anchor bolts.
5. Reconfirm that the column is level front to rear and that it is angled slightly outward side to side. Add or remove shims as required.
6. Torque all anchor bolts to 150 ft-lbs. (203 Nm), continually checking that the column is level as you proceed. If anchor bolts do not tighten to 150 ft-lbs. OR project more than 1 3/4" above the concrete surface (**Figure 9**), the concrete MUST be replaced by an appropriate concrete pad. (*Consult Product Manufacturer / Supplier for further details*).

**WARNING!** Do not use more than 1/2" (13mm) of shims. Anchor bolts supplied allow for a maximum of 1/2" (13mm) of shim. If more than 1/2" (13mm) of shims are required, DO NOT proceed with installation and contact Product Manufacturer / Supplier for further details.

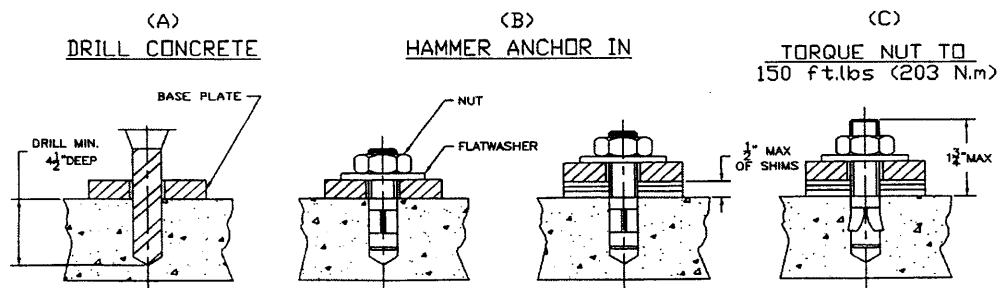



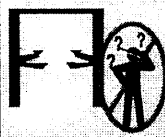

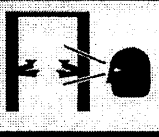

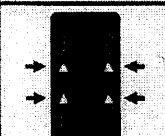
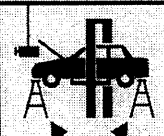
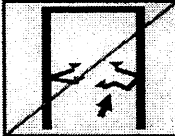



**Figure 9 – Anchor Bolts**

## 6 PERIODIC MAINTENANCE

1. Inspect lift daily, to assure the mechanical safety is operating properly.
2. Check the telescopic arms for movement. Clean any grease or oil from the lifting adapters.
3. Raise and lower the lift at the beginning of each shift, without a vehicle on, to verify the lift is leveled and operating properly. Perform hydraulic leveling procedure when the lift is out of level.
4. Lubricate safety dog mechanisms with penetrating oil monthly.
5. Grease arm pins supports monthly.
6. Check hydraulic fittings for tightness.
7. Annual lift inspection as per Automotive Lift Operation, Inspection and Maintenance (ALOIM).
8. Apply a small amount of grease to glide bearing tracks periodically.
9. Check lift for synchronization periodically.
10. Check bolts on carriage stops for tightness
11. Change hydraulic oil every two years.

**NOTE:** If you are unclear call your local representative immediately.

## 7 SAFETY AWARENESS - AUTOMOTIVE LIFT INSTITUTE (ALI)

		<b>CAUTION</b> 	<b>CAUTION</b> 	<b>SAFETY INSTRUCTIONS</b> 	<b>SAFETY INSTRUCTIONS</b> 
		<b>CAUTION</b> 	<b>CAUTION</b> 	<b>SAFETY INSTRUCTIONS</b> 	<p>The messages and pictographs shown are generic in nature and are meant to generally represent hazards common to all automotive lifts regardless of specific type.</p> <p>Funding for the development and validation of these labels was provided by the Automotive Lift Institute, P. O. Box 33116, Jacksonville, FL 32203-3116. They are protected by copyright. Sets of labels may be obtained from ALI or its member companies.</p> <p>© 2000 by ALI, Inc. ALI/ALI/00/01</p>
		<b>CAUTION</b> 	<b>CAUTION</b> 		

*Warning Labels for 2-post surface mounted lifts. Daily review of these Safety Messages and Warnings is suggested.*

# 8 PARTS MANUAL

## 8.1 LIFT ASSEMBLY

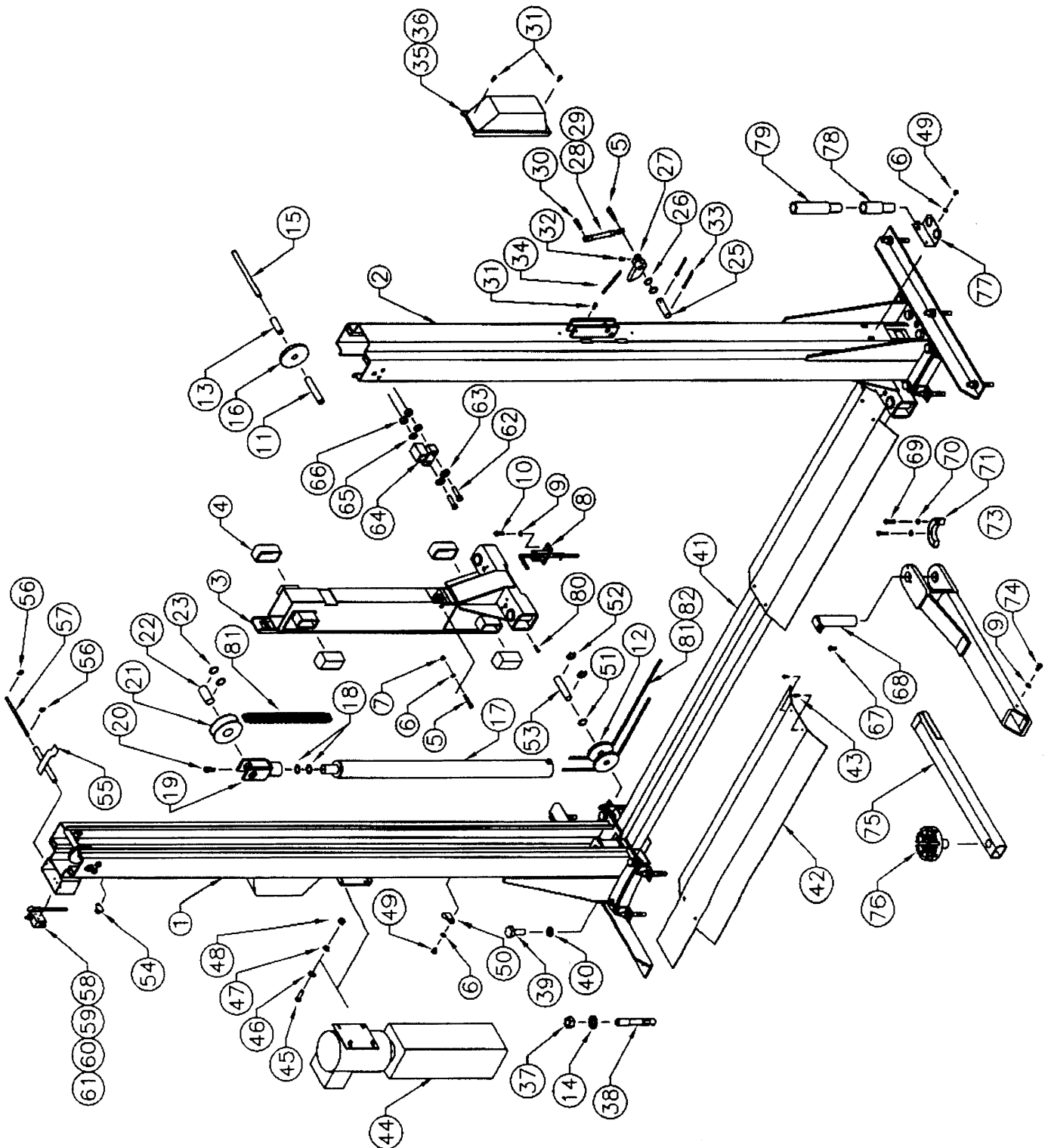

## 8.2 LIFT ASSEMBLY PARTS LIST

ITEM	QTY	DESCRIPTION	PART #
1	1	TOWER WELDMENT, L.S.	4-0925
2	1	TOWER WELDMENT, R.S.	4-0956
3	2	CARRIAGE WELDMENT	4-0765
4	8	GLIDE BEARINGS	2-0772
5	6	SHOULDER BOLT, 5/16"-NC x 1 1/4"	6-2491
6	7	LOCKWASHER, 1/4" ID	6-0056
7	4	HEX NUT, 1/4"-NC	6-0032
8	4	ARM LOCK ASSEMBLY	1-2038
9	4	LOCKWASHER, 3/8" ID	6-0058
10	8	SOC. HD CAP SCREW, 3/8"-NC x 1 1/4"	6-2048
11	2	PULLEY PIPE, LONG	1-2129
12	4	PULLEY ASSEMBLY	1-2141
13	2	PULLEY PIPE, SHORT	1-2128
14	14	FLATWASHER, 3/4" ID	6-0738
15	2	UPPER PULLEY PIN	1-2126
16	2	PULLEY ASSEMBLY - UPPER	1-2502
17	2	CYLINDER ASSEMBLY	3-0737
18	4	THRUST WASHER	6-0328
19	2	FORK WELDMENT	2-1637
20	2	SHOULDER BOLT, 1/2"-NC x 5/8"	6-0425
21	2	WHEEL CHAIN	2-1854
22	2	FORK PIN	1-2132
23	4	CIRCLIP, 1 1/4"	6-0340
24	2	LEAF CHAIN	1-2424
25	2	SAFETY PIN	1-0938
26	8	FLAT WASHER 51/64" ID x 1" OD	6-0808
27	2	SAFETY DOG	2-1793
28	2	ROD CLEVIS	1-2426
29	2	AIR CYLINDER	1-2425
30	2	SHOULDER BOLT, 5/16"-NC x 3/4"	6-0591
31	6	SELF TAPPING SCREW, #12 x 3/8"	6-2516
32	2	SELF TAPPING SCREW, #10 x 3/8"	6-0169
33	4	COTTER PIN, 1/8" x 1"	6-0267
34	2	SAFETY SPRING	1-1115
35	1	SAFETY COVER C/W DECALS L.S.	0-0865
36	1	SAFETY COVER C/W DECALS R.S.	0-0864
37	14	HEX NUT, 3/4"-NC	6-0737
38	14	WEDGE ANCHOR, 3/4"-NC x 5 1/2"	6-1379
39	12	HEX HD BOLT, 3/4"-NC x 2"	6-2426
40	12	LOCKWASHER, 3/4" ID	6-0259
41	1	BASEFRAME WELDMENT	4-0764
42	2	LINE COVER	2-1847
43	8	SELF TAPPING SCREW, #12 x 1/2"	6-1134
44	1	POWERPACK, 230V / 1PH / 60HZ	6-2055
45	4	HEX HD BOLT, 5/16"-NC x 1"	6-0293
46	4	FLATWASHER, 5/16" ID	6-0295
47	4	LOCKWASHER, 5/16" ID	6-0674
48	4	HEX NUT, 5/16"-NC	6-0294
49	3	ROUND HD SCREW, 1/4"-NC x 3/8"	6-1353
50	1	TUBE CLAMP	6-0536

ITEM	QTY	DESCRIPTION	PART #
51	2	LOWER PULLEY PIN	1-2130
52	4	CIRCLIP, 3/4"	6-2422
53	4	THRUST WASHER, TRA-1220	6-0502
54	4	ELECTRICAL CABLE CLIP	6-1759
55	1	ROCKER ARM	1-2308
56	1	LIMIT SWITCH PIN	1-2427
57	2	CIRCLIP, 5/16"	6-2500
58	1	MICROSWITCH BOX	6-0914
59	1	ELBOW, 90 DEG CONNECTOR	6-0947
60	1	MICROSWITCH	6-0916
61	80"	ELECTRICAL CABLE	8-0030
62	8	HEX HD BOLT, 1/2"-NC x 2 1/4"	6-0315
63	8	FLATWASHER, 1/2" ID	6-0248
64	4	CARRIAGE STOPS	1-2500
65	8	LOCKWASHER, 1/2" ID	6-0059
66	8	HEX NUT, 1/2"-NC	6-0035
67	4	HEX HD BOLT, 5/16"-NC x 3/4"	6-0423
68	4	ARM PIN	2-1594
69	8	HEX HD BOLT, 5/16"-NC x 1 1/4"	6-2059
70	8	FLATWASHER, 5/16" ID	6-0295
71	4	ARM LOCK GEAR	1-2044
72	4	OUTER ARM WELDMENT	3-0850
73	4	ARM ASSEMBLY C/W PIN	4-0949-6
74	4	HEX HD BOLT, 3/8"-NC x 3/4"	6-0030
75	4	INNER ARM WELDMENT	3-0742
76	4	ADAPTER PAD ASSEMBLY	1-2045
77	2	ADAPTER HOLDER	1-2012
78	4	3" PAD ADAPTER	1-1993
79	4	6" PAD ADAPTER	2-1580
80	4	GREASE NIPPLE	6-0000
81	2	LEAF CHAIN (CUT TO SIZE)	1-2424

### 8.3 HYDRAULIC SYSTEM

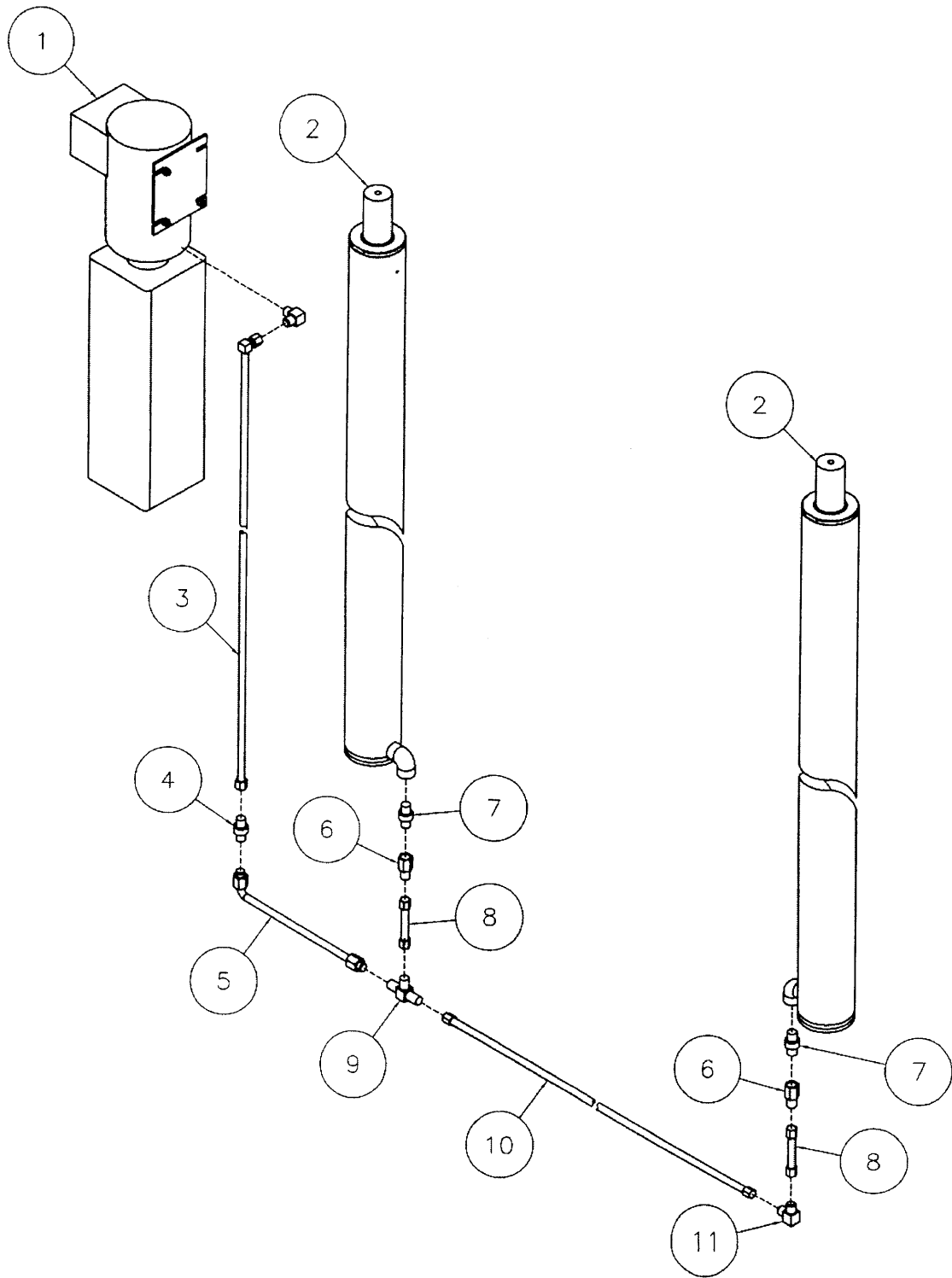

#### 8.4 HYDRAULIC SYSTEM PARTS LIST

ITEM	QTY	DESCRIPTION	PART #
1	1	POWER PACK, 208-230V/1PH	6-2055
	1	POWER PACK, 208-230V/3PH	6-2665
2	2	CYLINDER ASS'Y	3-0737
3	1	HYDRAULIC HOSE ASS'Y	2-1230
4	1	ADAPTER, 3/8" JIC M – 3/8" JIC M	6-0286
5	1	HYDRAULIC TUBE ASS'Y	1-2435
6	2	FLOW CONTROL	6-1520
7	2	ADAPTER, 1/4" NPT M – 3/8" NPT M	6-0270
8	2	HYDRAULIC TUBE, 3/8" OD x 2 5/8" LG	1-0281
9	1	"T" FITTING	6-1372
10	1	HYDRAULIC HOSE ASS'Y	2-1849
11	1	ELBOW, 90° 3/8" JIC M - 3/8" JIC M	6-0922
		<i>3 PH POWERPACK INCLUDES THE FOLLOWING (NOT SHOWN)</i>	
*	1	CONTACTOR BOX (WIRE FOR 3PH)	6-1575
*	1	CONTACTOR BRACKET	2-1130
*	1	COVER PLATE	1-1369
*	2	HEX BOLT, 1/4"-NC x 1" LG	6-0008
*	4	LOCKWASHER, 1/4"	6-0056
*	2	HEX NUT, 1/4"-NC	6-0032
*	2	STRAIN RELIEF	6-0094
*	2FT	CABLE, 14/4	8-0287





## 8.6 AIR SYSTEM PARTS LIST

ITEM	QTY	DESCRIPTION	PART #
1	1	AIR VALVE & FILTER ASSY	2-1820
2	1	UNION "T"	6-2433
3	2	90 DEG ELBOW, 4mm POLYTUBE TO M5	6-1504
4	2	SAFETY DOG MACHINED	2-1793
5	2	ROD CLEVIS	1-2426
6	2	AIR CYLINDER	1-2425
7	2	SHOULDER BOLT, 5/16" x 3/4"	6-0591
8	2	SHOULDER BOLT, 5/16" x 1 1/4"	6-2491

## 8.7 POWER PACK:

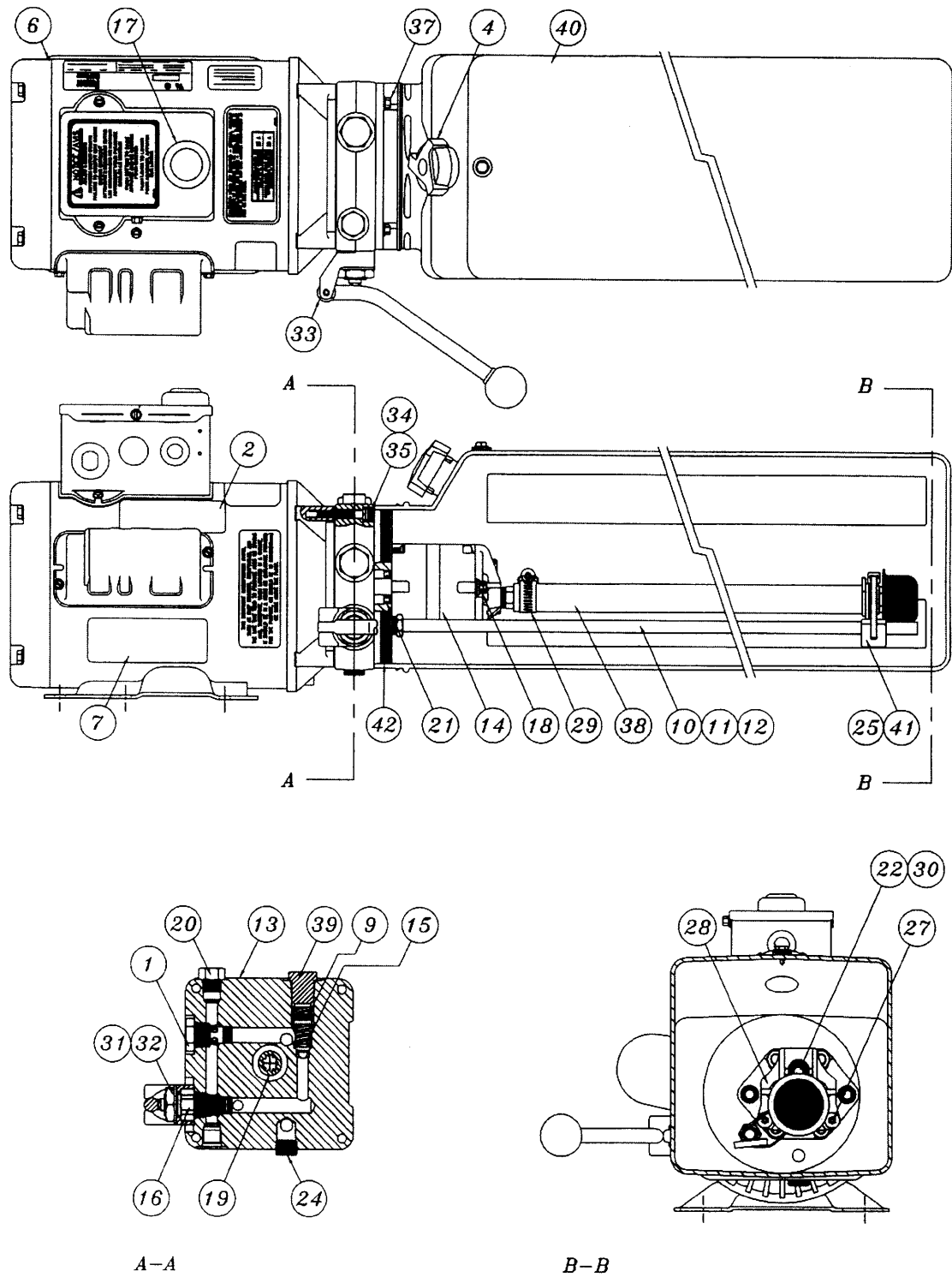

## 8.8 POWER PACK PARTS LIST:

#6-2055 (AB-1381) 208-230V/1PH/60Hz

#6-2665 (AD-1044) 208-230V/1PH/60Hz

ITEM	QTY.	DESCRIPTION	PART #
1	1	VALVE CARTRIDGE CHECK	6-1087
2	1	LABEL INSTALLATION AUTOHOIST	6-2136
4	1	BREATHER CAP & BLADDER	6-1376
6	1	MOTOR AC 208-230V. 2HP/1PH/60Hz, BLK	6-2139
	1	MOTOR AC 208-230V. 2HP/3PH/60Hz, BLK	6-1079
7	1	LABEL WARNING AUTOHOIST	6-2149
9	1	SPRING 0.480" x 0.063" x 0.42" COMP	6-2151
10	1	RETURN HOSE 3/8" OD x 21.5"	6-2152
11	1	COMPRESSION TUBE NUT	6-2153
12	1	COMPRESSION TUBE SLEEVE	6-2154
13	1	ENDHEAD UNIVERSAL AUTOHOIST	6-2155
14	1	PUMPASSY 2.5 CC/REV. SHORT SPLINE	6-1958
15	1	RELIEF ASSEMBLY FIXED 190 BAR	6-1319
16	1	VALVE CARTRIDGE RELEASE MANUAL	6-0880
17	1	WIRING ASSEMBLY AC 1PH FENNER	6-2156
18	2	BOLT 5/16"-24 x 3.00" TORX G8	6-1090
19	1	COUPLING SAE 9T-20/40 1.260"	6-0774
20	1	PLUMBING PLUG 9/16" SAE	6-2157
21	1	SEAL SHAFT 0.500" x 1.00" x 0.25"	6-2158
22	1	WASHER 0.338" x 0.625" x 0.060" STEEL	6-2159
24	1	PLUMBING PLUG 3/8" NPT	6-2161
25	1	PLUMBING MAGNET	6-2162
27	2	SCREW TAPTITE M6 x 1.0 12MM TORX	6-2164
28	1	COVER ASSY SUCTION	6-2165
29	1	PLUMBING CLAMP HOSE ADJ. INLET	6-2166
30	1	BOLT 5/16"-18 x 1.00" SHCS	6-1392
31	1	NUT 3/4"-16 x 1" HEX x 0.250" STEEL	6-2167
32	1	WASHER 3/4" INT. TOOTH LOCK	6-2168
33	1	BRACKET - HANDLE ASSY REL BLACK	6-0776
34	4	BOLT M6 x 1.0 35MM SOC HD	6-2169
35	4	WASHER 1/4" LOCK HI-COLLAR	6-2170
37	4	BOLT #12-24 x 0.50" HEX WSHRHD	6-1091
38	1	PLUMBING ASSY INLET 17.24 (3)	6-0786
39	1	RELIEF VALVE CAP ASSEMBLY	6-1089
40	1	TANK PLASTIC 6.7 OS 22.50" BLK	6-1399
41	1	CABLE TIE 8" LONG WHITE	6-1846
42	1	O-RING 2-348 BUNA	6-0875

## 8.9 LIFT MAINTENANCE GUIDELINES – CABLE EQUALIZATION

### Two Post Lifts

#### Safety Instructions

Read operating and safety manuals before using any lift  
Do not operate a lift that has been damaged or is in disrepair  
Proper inspection and maintenance is necessary for safe operation

#### *General*

Check all hydraulic lines and fittings for pinch points , damage , cracks or leaks  
Check all electrical wiring for pinch points , cracks or damage  
Check all moving parts for uneven or excessive wear  
Repair or replace all damaged , defective , worn or broken components immediately

#### Cable Equalized Two Post Lift

- clean and re-grease slide block channels inside of both columns every two months
- grease arm pins every two months
- check and lubricate safety dogs and safety cable adjustment every two months
- dismantle , clean and lubricate arm restraints every two months
- dismantle and clean inner arms every four months
- lubricate cable pulleys every four months
- check equalizing cables and adjust every four months or as required
- change hydraulic oil every two years
- periodically check anchor bolts and re-torque if required

#### Hydraulically Equalized Two Post Lift

- check and adjust hydraulic level weekly or as required
- clean and re-grease slide block channels inside of both columns every two months
- grease arm pins every two months
- check and lubricate safety dogs and safety cable adjustment every two months
- dismantle , clean and lubricate arm restraints every two months
- dismantle and clean inner arms every four months
- change hydraulic fluid every two years
- periodically check anchor bolts and re-torque if required

Lubrication : Where grease is required > multi-purpose lithium grease  
Where lubricating oil is required > multi-purpose SAE 30 lubricating oil  
Where hydraulic oil is required > ISO 32 10W - non detergent hydraulic oil

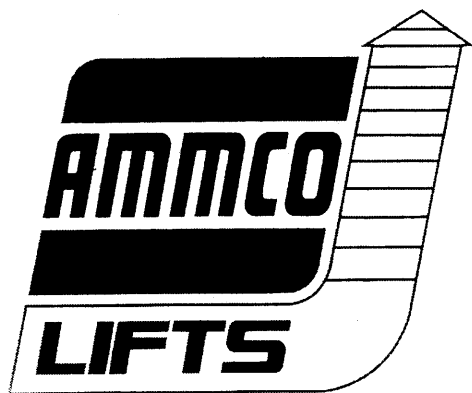

# INSTALLATION and OPERATION MANUAL

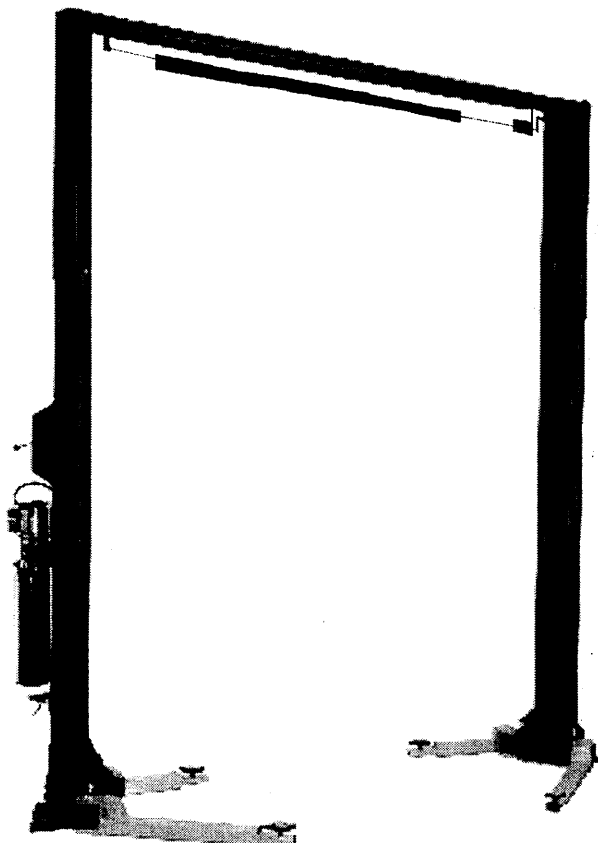

**9,000 LB. SYMMETRIC 2 POST  
S29TS □ □ - R/B/M, 1/3**

**READ and SAVE THIS  
INSTRUCTION MANUAL**

# TABLE OF CONTENTS

	PAGE
<b>1 SAFETY AND OPERATING INSTRUCTIONS .....</b>	<b>1</b>
<b>2 SPECIFICATIONS.....</b>	<b>2</b>
<b>3 CONTENTS.....</b>	<b>3</b>
<b>4 INSTALLATION REQUIREMENTS AND TOOLS .....</b>	<b>3</b>
<b>5 INSTALLATION INSTRUCTIONS .....</b>	<b>4</b>
5.1 UNPACKING PROCEDURE .....	4
5.2 BAY LAYOUT.....	5
5.3 SAFETY SHUT-OFF BAR INSTALLATION .....	5
5.4 SAFETY SHUT-OFF BAR ADJUSTMENT .....	6
5.5 TOWER POSITIONING AND SETUP .....	7
5.6 ROUTING OF EQUALIZATION CABLE.....	8
5.7 ARM INSTALLATION .....	9
5.8 ARM LOCKS INSTALLATION .....	10
5.9 SAFETY RELEASE CABLE ROUTING AND ADJUSTMENT .....	11
5.10 POWER PACK INSTALLATION.....	12
5.11 HYDRAULIC SYSTEM INSTALLATION .....	13
5.12 HYDRAULIC SYSTEM BLEEDING .....	14
5.13 TOWER POSITIONING AND ANCHORING .....	15
5.14 SHIMMING OF THE REMAINING TOWER.....	16
<b>6 LIFT MAINTENANCE GUIDLINES .....</b>	<b>17</b>
6.1 SAFETY INSTRUCTIONS.....	17
6.2 PERIODIC MAINTENANCE.....	17
<b>7 SAFETY AWARENESS - AUTOMOTIVE LIFT INSTITUTE (ALI).....</b>	<b>18</b>
<b>8 PARTS MANUAL .....</b>	<b>19</b>
8.1 LIFT ASSEMBLY.....	19
8.2 LIFT ASSEMBLY PARTS LIST .....	20
8.3 HYDRAULIC SYSTEM .....	22
8.4 HYDRAULIC SYSTEM PARTS LIST .....	23
8.5 POWER PACK:.....	24
8.6 POWER PACK PARTS LIST:.....	25

# 1 SAFETY AND OPERATING INSTRUCTIONS

1. Read all instructions.
2. Inspect lift daily. Do not operate if it malfunctions or problems have been encountered.
3. Never attempt to overload the lift. The manufacturer's rated capacity is shown on the identification label on the power side column. Do not override the operating controls or the warranty will be void.
4. Only trained and authorized personnel should operate the lift. Do not allow customers or bystanders to operate the lift or be in the lift area.
5. Position the lift support pads to contact the vehicle manufacturer's recommended lifting points. Raise the lift until the pads contact the vehicle. Check pads for secure contact with the vehicle, then raise the lift to the desired working height.
6. Some pickup trucks may require an optional truck adapter to clear running boards or other accessories. **NOTE:** Always use all 4 arms to raise and support vehicle.
7. **Caution! Never work under the lift unless the mechanical safety locks are engaged.**
8. Note that the removal or installation of some vehicle parts may cause a critical load shift in the center of gravity and may cause the vehicle to become unstable. Refer to the vehicle manufacturer's service manual for recommended procedures.
9. Always keep the lift area free of obstruction and debris. Grease and oil spills should always be cleaned up immediately.
10. Never raise vehicle with passengers inside.
11. Before lowering check area for any obstructions.
12. Before driving vehicle between the towers, position the arms to the drive-through position to ensure unobstructed clearance. Do not hit or run over arms as this could damage the lift and/or vehicle.
13. Before removing the vehicle from the lift area, position the arms to the drive-through position to prevent damage to the lift and /or vehicle.
14. Care must be taken as burns can occur from touching hot parts.
15. Do not operate equipment with a damaged cord or if the equipment has been dropped or damaged – until a qualified serviceman has examined it.
16. Do not let cord hang over table, bench or counter or come in contact with hot manifolds or moving fan blades.
17. If an extension cord is necessary, a cord with a current rating of two or more than that of the equipment should be used. Cords rated for less current than the equipment may overheat. Care should be taken to arrange the cord so that it will not be tripped over or pulled.
18. Always unplug the equipment from electrical outlet when not in use. Never use the cord to pull the plug from the outlet. Grasp plug and pull to disconnect.

## 2 SPECIFICATIONS

Capacity:  
 Overall Width:  
 Width Between Columns:  
 Drive-Thru Width:  
 Overall Height:  
 Under Bar Clearance:  
 Height to Lowered Lift Pads:  
 Height to Lift Pad (3" Adapter):  
 Height to Lift Pad (6" Adapter):  
 Retracted Arm Length:  
 Extended Arm Length:  
 Maximum Lifting Height (6" Adapter):  
 Lift Time:  
 Power Requirements (Standard):

9000 lbs.	4082 kg
144"	3658 mm
120"	3048 mm
109"	2769 mm
144"	3658 mm
140"	3556 mm
4 1/2"	114 mm
7 1/2"	191 mm
10 1/2"	267 mm
35 1/4"	895 mm
53 1/2"	1359 mm
79 1/4"	2013 mm
45 seconds	
230 Volts AC, 1 Ph., 60Hz.	

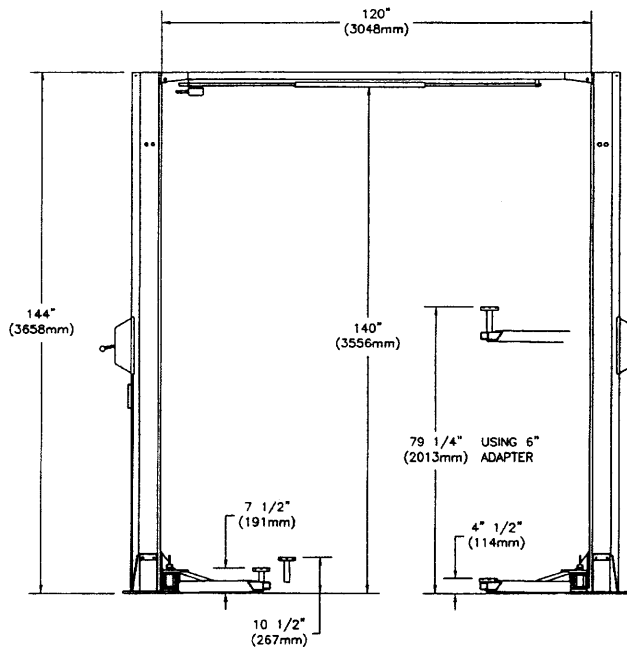

Figure 1 – Front View

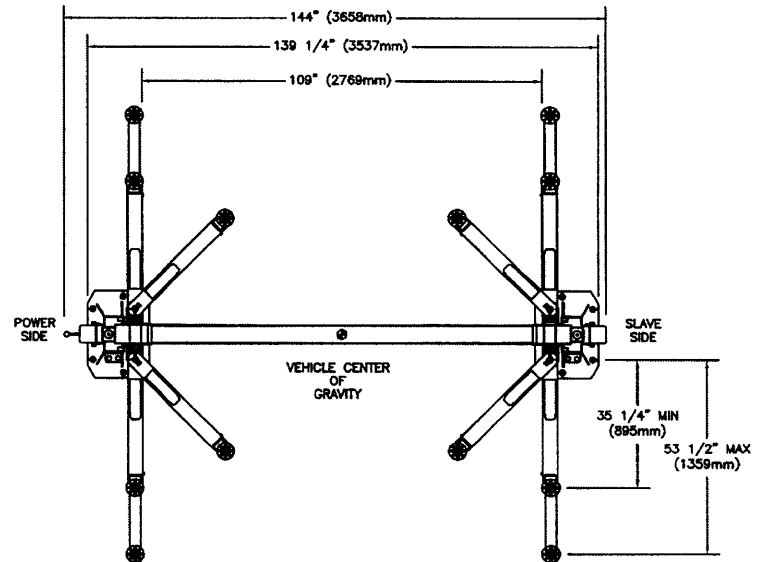

Figure 2 – Top View



### 3 CONTENTS

The complete lift is contained in two (2) packages:

1. The **main structural components** are packed in a steel frame.
2. The remaining parts are packed in an **accessory box**.

#### **Main Structural Components includes:**

- 1pc. - Power side tower and carriage assembly
- 1pc. - Slave side tower and carriage assembly
- 1pc. - Crossmember
- 1pc. - Actuator Bar w/ foam

#### **Accessory box contents:**

- 4pcs. - Locking Arm Assembly w/arm pins
- 2pcs. - Safety Covers w/Decals
- 1pc. - Hardware Package w/Packing List
- 1pc. - Actuator Extension
- 1pc. - Actuator Mounting Bracket
- 1pc. - Power Pack
- 4pc. - Arm Locks
- 1pc. - Safety Release Cable
- 1pc. - Hydraulic Hose (Long)
- 1pc. - Hydraulic Hose (Short)
- 2pcs. - Equalizing Cable w/Hex Nuts
- 1pc. - ALI manual "Lifting It Right"
- 1pc. - Automotive Lift Safety Tips
- 1pc. - Automotive Lift, Operation, Inspection and Maintenance manual
- 1pc. - "ALI" Quick Reference Guide
- 1pc. - Owner's manual
- 1pc. - Safety Shut-off Microswitch Assembly (Components)

### 4 INSTALLATION REQUIREMENTS AND TOOLS

**IMPORTANT: It is the user's responsibility to provide a satisfactory installation area for the lift. Lifts should only be installed on level concrete floors with a minimum thickness of five (5) inches or 130 mm. Concrete must have a minimum strength of 4000 psi or 30 MPa and should be aged thirty (30) days prior to installation. Please consult the architect, contractor or engineer if doubt exists as to the strength and feasibility of the floor to enable proper lift installation and operation.**

**It is the user's responsibility to provide all wiring for electrical hook-up prior to installation and to insure that the electrical installation conforms to local building codes. Where required, it is the user's responsibility to provide an electrical isolation switch located in close proximity to the lift that will enable emergency stop capability and isolate electrical power from the lift for any servicing requirements.**

## **Tools Required:**

- a. 16ft. Measuring Tape
- b. Chalk Line
- c. Rotary Hammer Drill
- d. 3/4" diameter Masonry Drill Bit
- e. Hammer
- f. SAE Wrenches and Ratchet Set
- g. 2ft. Level
- h. 4ft. Level
- i. Crow Bar
- j. 12ft. Step Ladder
- k. Side Cutters
- l. Screwdrivers
- m. 4" x 4" Wooden Blocks (for unpacking)

## **5 INSTALLATION INSTRUCTIONS**

When the lift arrives on site:

- Read the owner's manual and make sure the installation instructions are fully understood.
- Check for any freight damages.
- Check the contents of the accessory and hardware boxes to make sure no parts are missing.
- Gather all the tools listed above.

### **5.1 UNPACKING PROCEDURE**

1. **Important!** Place the main structural components on wooden blocks so that the steel shipping frames can be removed.
2. Remove the plastic wrapping.
3. Remove the crossmember, and the actuator bar.
4. Unbolt the steel shipping frames.
5. Lay each tower on the floor with the carriage side up.
6. Check the installation area for obstructions. (Lights, Heating Ducts, Ceiling, Floor Drains, etc.)
7. Prepare the bay by selecting the location of the lift relative to the walls. Clear the installation area of all packaging materials to avoid trip hazards. Draw a chalk line on the floor to represent the centerline of the bay then draw a second chalk line at 90° for locating the lift towers. Refer to **Figure 3**.

## 5.2 BAY LAYOUT

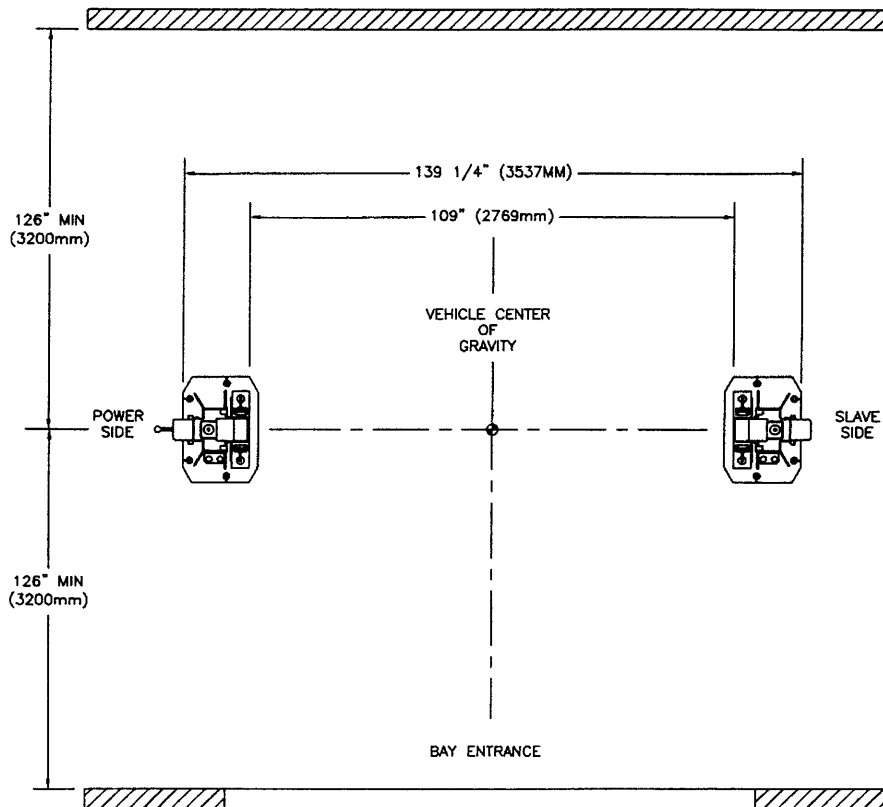

Figure 3 – Bay Layout

## 5.3 SAFETY SHUT-OFF BAR INSTALLATION

**Note:** The safety shut off will disconnect the power to the power pack when an obstruction touches the padded bar or the carriages reach their maximum height. The safety shut off switch is factory pre-wired. Refer to Figure 4.

Note: This procedure can be done on the floor.

1. Attach the Actuator Mounting Bracket (1-1378) to the crossmember using one 1/4" NC x 3/4" lg. hex head bolt (6-0178), one 1/4" ID lockwasher (6-0056), and one 1/4" NC hex nut (6-0032).
2. Attach the Actuator Bar to the Actuator Mounting Bracket using one 1/4" NC x 1 1/2" lg. hex head bolt (6-0205), one 1/4" ID lockwasher (6-0056), and one 1/4" NC hex nut (6-0032).
3. Slide Safety Shut-Off Microswitch Assembly over the open end of actuator bar and bolt the assembly to the crossmember using two (2) 1/4" NC x 3/4" lg. hex head bolts (6-0178), two (2) 1/4" ID lockwashers (6-0056), and two (2) 1/4" NC hex nut (6-0032).

4. Install the 1/4" NC x 2" lg. hex bolt (6-0741) into the actuator extension (1-1379) then attach the 1/4" NC hex nut (6-0032) from the other side to hold the bolt in place.

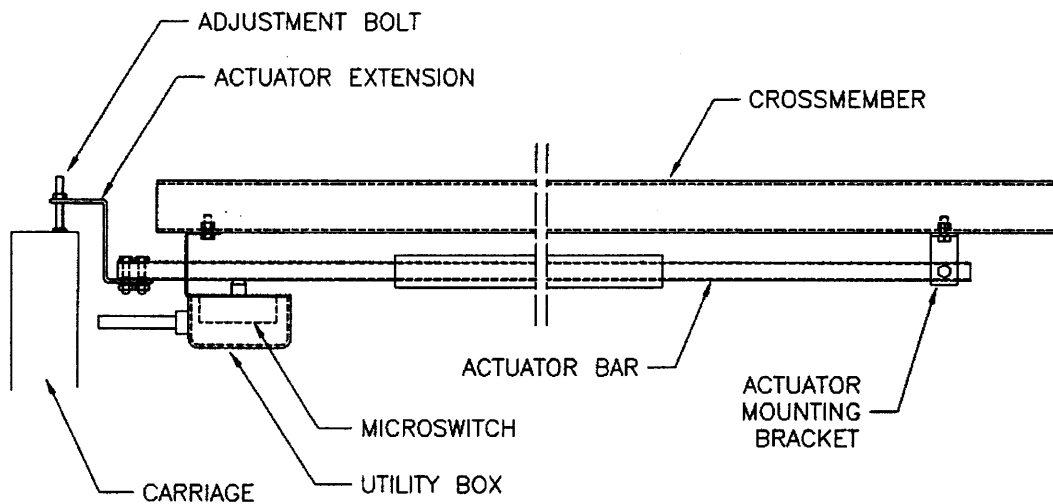

**Figure 4 – Safety Shut-Off Bar Installation**

#### **5.4 SAFETY SHUT-OFF BAR ADJUSTMENT**

**Note: This procedure must be done last. Refer to Figure 4.**

1. When the lift is fully installed, leveled and operational, extend the carriages to their full upper limit.
2. Lower the carriages about 1/4" to 1/2".
3. Bolt the Actuator Extension onto the open end of actuator bar using two (2) 1/4" NC x 1 1/4" lg. hex head bolts (6-0027), two (2) 1/4" ID lockwashers (6-0056), and two (2) 1/4" NC hex nuts (6-0032).
4. Adjust the 1/4" NC x 2" lg. hex bolt so that the end of the bolt is in contact with the carriage. Tighten the 1/4" NC hex nut on the bolt.

## 5.5 TOWER POSITIONING AND SETUP

1. Locate the power side and slave side towers and position them as shown in **Figure 3**. Double check all the dimensions in the layout.
2. Using a stepladder, install the crossmember using eight (8)  $\frac{1}{2}$ "-16UNC x 1  $\frac{1}{4}$ " lg. hex head bolts, eight (8)  $\frac{1}{2}$ " ID lock washers, eight (8)  $\frac{1}{2}$ " hex nuts and eight (8)  $\frac{1}{2}$ " flat washers. See **Figure 5**
3. Check the towers to make sure they are located, and positioned in the correct location. Refer to **Figure 3**.

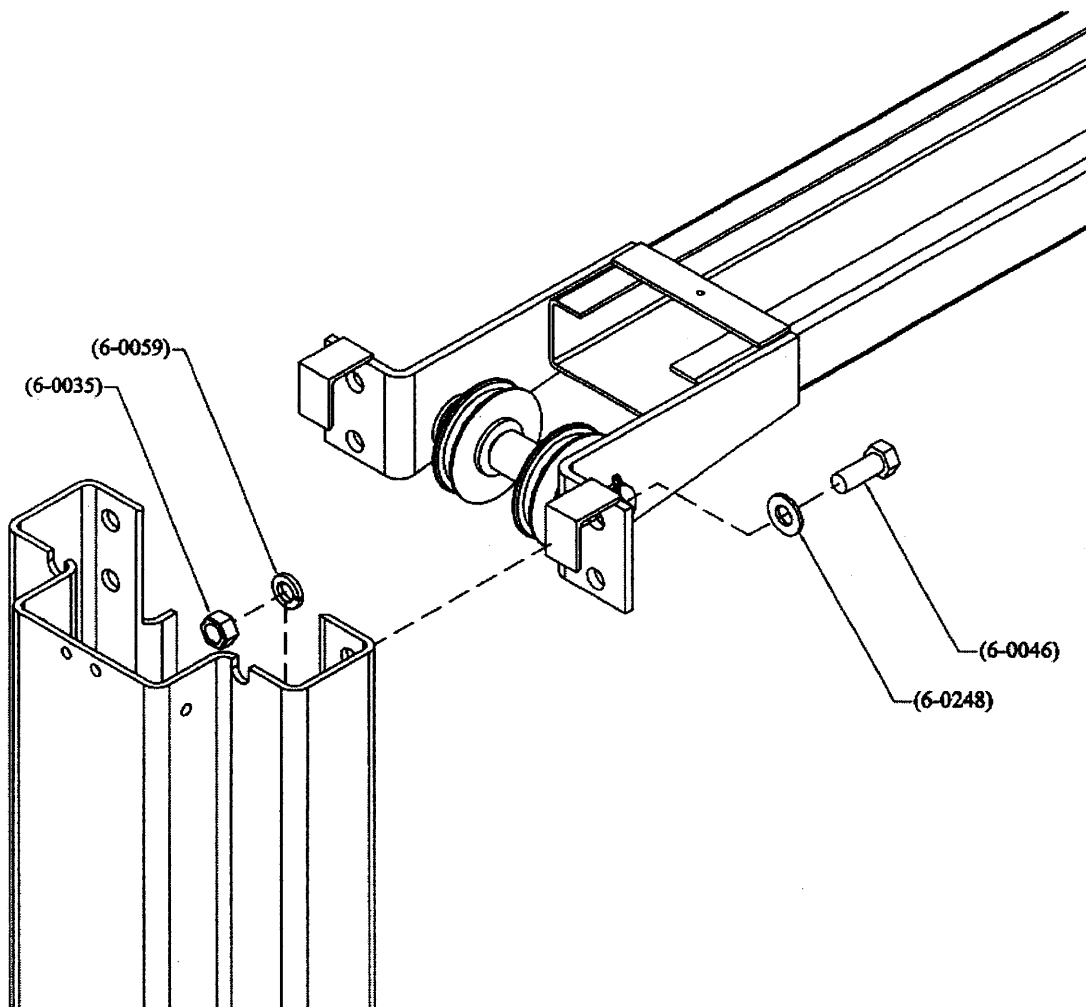
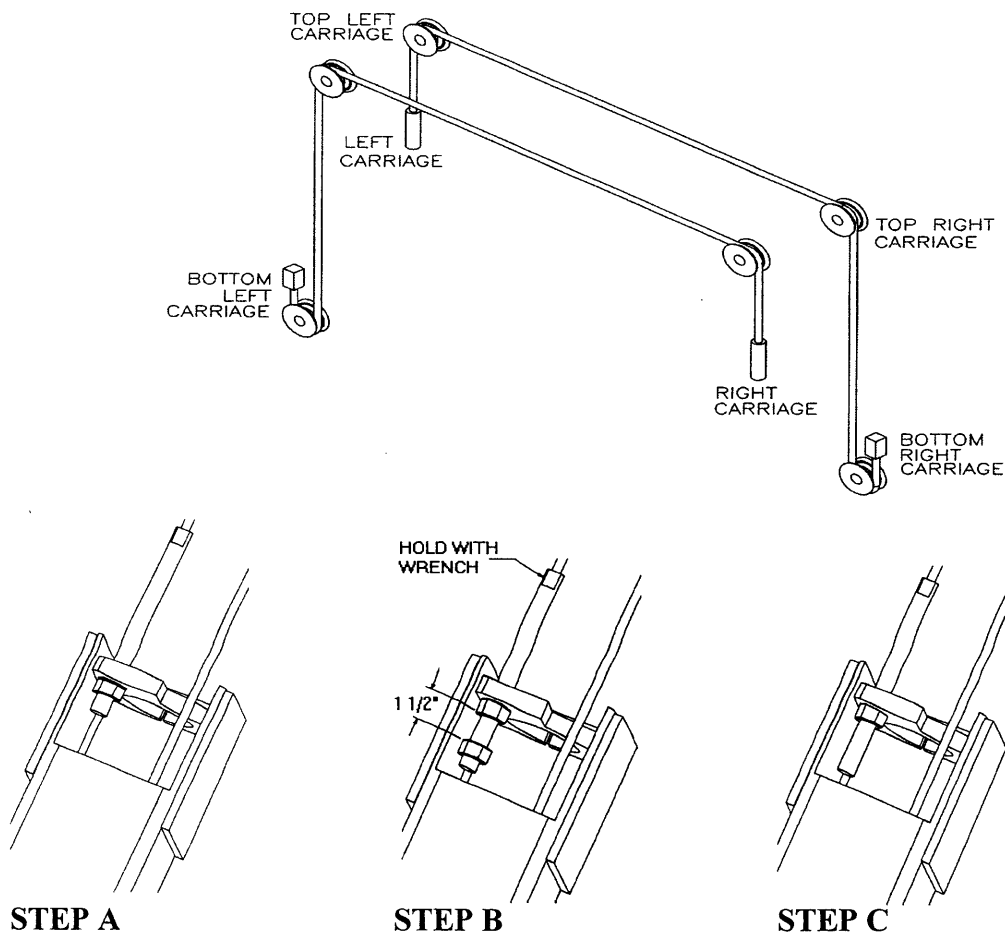

**Figure 5 – Crossmember Assembly**

## 5.6 ROUTING OF EQUALIZATION CABLE

Use **Figure 6** to route the equalization cables.

1. Remove the carriage covers and manually lift the carriages to the first safety latch.
2. Remove the  $\frac{1}{2}$ "-13 UNC nylon locknuts off the equalization cables and retain for use later.
3. Route the equalization cables as shown in Figure 6. Using the first cable, insert the shorter threaded stud up through the  $\frac{9}{16}$ " diameter hole in the bottom of the carriage and feed it up through the opening in the top of the carriage. Run the nylon locknut onto the shorter stud so that  $\frac{1}{2}$ " of threads extend past the top of the locknut and pull the cable back into the carriage. Route the opposite end of the cable around the sheave at the base of the column and up around the sheave at the top of the column. Run the cable across the crossmember and around the sheave at the top of the other column. Insert the longer threaded stud into the  $\frac{9}{16}$ " diameter hole in the top of the carriage.
4. Use a wrench to hold the top of the threaded stud to prevent it from rotating. Tighten the locknut onto the longer threaded stud enough to remove all visible cable slack. Repeat steps 2 to 4 for the other equalizing cable (**Step A**).
5. Using two wrenches, tighten the locknut at the top of the carriage approximately  $1\frac{1}{2}$ " (**Step B**) past the point where visible cable slack has been removed. Repeat for the other cable.

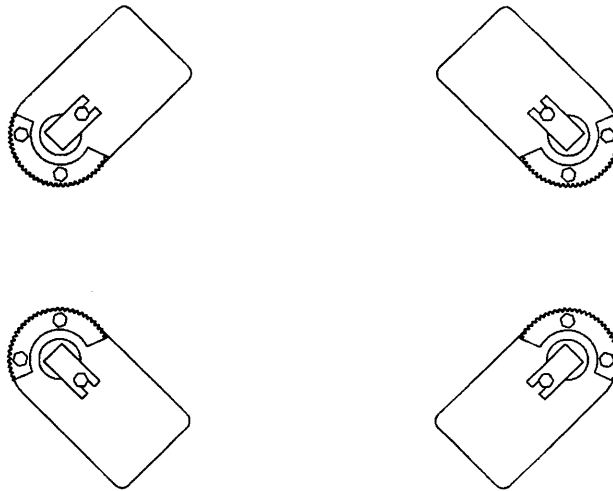

**Figure 6 – Equalization Cables**

## 5.7 ARM INSTALLATION

1. Remove the four (4) 5/16"-18UNC x 3/4"LG. hex head bolts that are holding the arm pins to the arm. Install the arms on the carriages.
2. Grease and insert arm pins. Align the notch on each arm pin with the tapped hole on the arm, and using the 5/16"-18UNC x 3/4"LG. hex head bolt removed in previous step, reinstall and tighten securely.
3. Using two (2) 5/16"-18UNC x 1 1/4" LG. hex head bolts and two (2) 5/16" flatwashers, attach each arm lock gear as shown in **Figure 7**.

FRONT



REAR

**Figure 7 – Arm Installation**

## 5.8 ARM LOCKS INSTALLATION

Using two (2) 3/8"-16UNC x 1" LG. socket head cap screws, and two (2) 3/8" ID lockwashers, install the arm lock assemblies as shown in **Figure 8**. Before tightening completely, make sure that the arm lock has full contact with the arm lock gear by pushing it firmly against the arm.

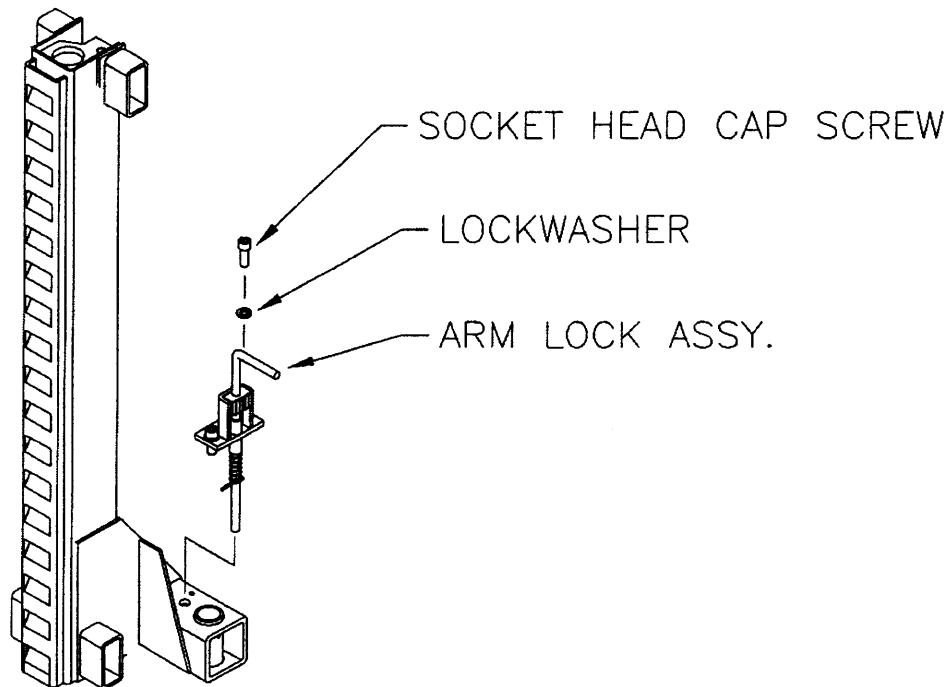

**Figure 8 – Arm Lock Installation**



## 5.9 SAFETY RELEASE CABLE ROUTING AND ADJUSTMENT

The mechanical safety automatically engages. To release the mechanical safety, you must first raise the lift approximately 2", then pull the safety release lever down. This disengages the power side safety dog and activates the safety cable to release the slave side safety dog.

1. Install the safety pulley on each tower as shown in **Figure 9**. Attach the safety pulley to the tower using the 3/8" x 5/8" LG. shoulder bolt, 5/16" lockwasher and 5/16" hex nut.

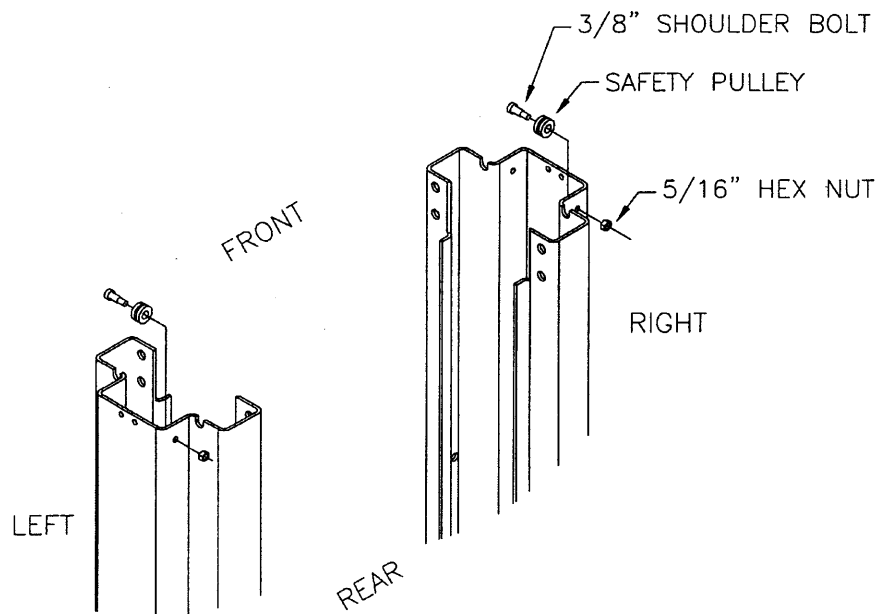

**Figure 9 - Safety Release Pulley Installation**

2. Refer to **Figure 10** for safety release cable routing. The end of the cable that has a collar attaches to the slave side tower. The free end is fixed to the power side tower using two (2) wire rope clips.
3. Install the safety release handle onto the power side safety dog
4. Start routing the safety release cable from the slave side of crossmember. Feed the cable over the small pulley, then guide the cable down along the inside of the slave side tower. Pull the cable out through the opening in the back of the tower near the safety dog.
5. Guide the cable up under the large pulley towards the end of the safety dog. Remove the 3/8" x 1 1/2" shoulder bolt from the safety dog. Feed the shoulder bolt through the collar of the safety release cable and then replace the shoulder bolt securely to the safety dog.
6. Repeat step 2 for the power side tower.

7. Guide the cable up under the large pulley and then over the small pulley towards the safety dog as shown in Figure 10. Wrap the cable around the thimble (attached to the safety dog with a 3/8" x 1 1/2" lg. shoulder bolt) and then clamp it using two (2) wire rope clips. Do not tighten fully at this stage.
8. Adjust the cable length so that both safety dogs travel from full engagement position to full release position when the safety release handle is pulled. **Tighten both wire rope clips firmly when adjustment is completed.**

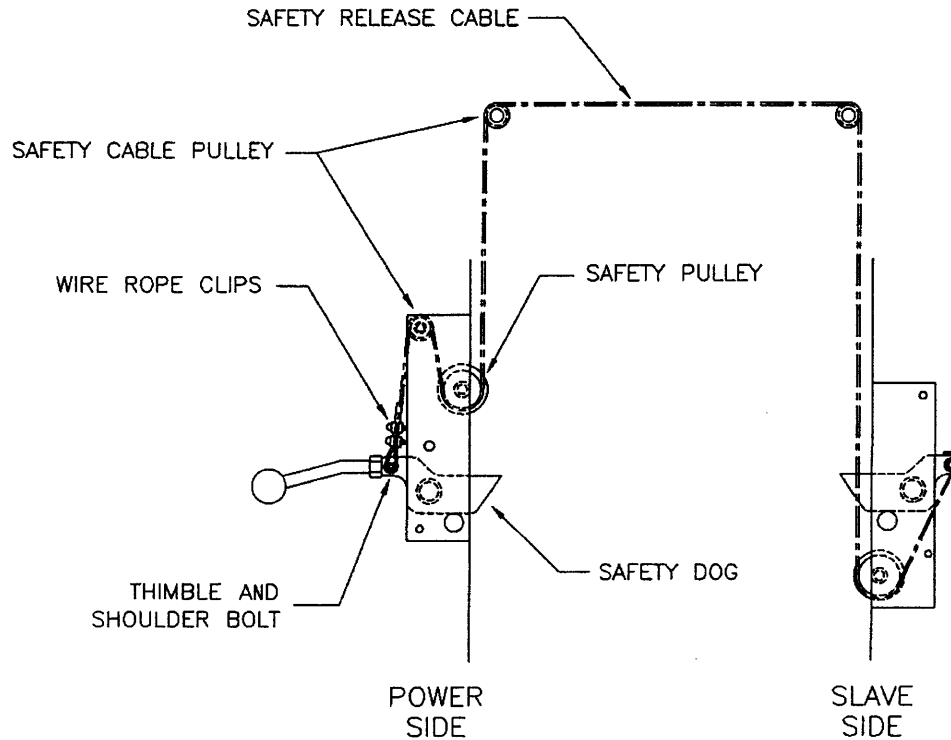

**Figure 10 – Safety Cable Release Routing and Adjustment**

### 5.10 POWER PACK INSTALLATION

1. Remove the **red** plastic cap located at the rear of the power pack, and install the "T" fitting located in the hardware kit.
2. Bolt power pack to the mounting bracket on the power side tower using four (4) 5/16"-18UNC x 1"LG. hex head bolts, four (4) 5/16" ID lock washers, four (4) 5/16" ID flat washers and four (4) 5/16"-18UNC hex nuts. Do not tighten.
3. Remove the filler cap from the powerpack and fill the reservoir with approximately 4.5 Gal. (18L) of ISO32 hydraulic oil (10 wt. hydraulic oil). Remove breather screw when filling and replace when full.
4. A **certified electrician** must connect the 230Volt/1Ph power to the motor. The electrical diagram is provided, refer to **Figure 12**.

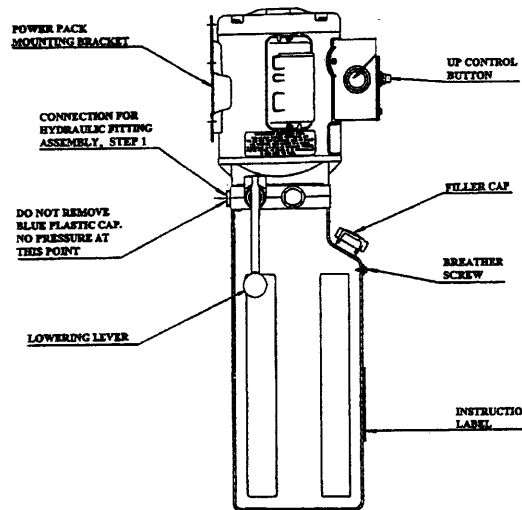

**Figure 11 – Powerpack Details**

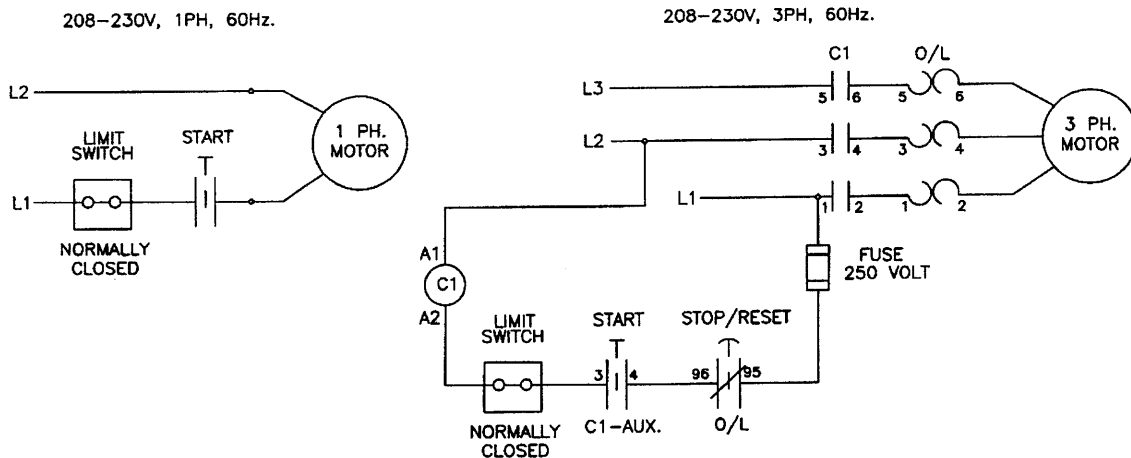

**Figure 12 – Electrical Diagram**

## 5.11 HYDRAULIC SYSTEM INSTALLATION

### REFER TO HYDRAULIC PARTS LIST

1. Connect the 45° end of the long hose to the “T” fitting on the powerpack.
2. Connect the 45° end of the short hose to the other end of the “T” fitting.
3. Remove the plastic cap from the bottom of the power side cylinder and connect the 90° end of the short hose to the cylinder.
4. Loop the hydraulic hose up the power side tower, across the overhead and down the slave side tower. Place rubber grommets (item 68 in the lift assembly) between the tower and the hose at the top of each tower.

5. Remove the plastic cap from the bottom of the slave side cylinder and connect the 90° end of the long hose to the cylinder.
6. The long hydraulic hose must be fixed to the towers using six (6) hose clamps. Screw the hose clamps into the weld nuts on the towers using 1/4"-20UNC x 3/8"lg. round head screws.
7. The long hydraulic hose must be fixed to the crossmember using two (2) hose clamps. Screw the hose clamps into the crossmember using #10 x 3/8" lg. self threading screws.

## 5.12 HYDRAULIC SYSTEM BLEEDING

1. Crack the caps located at the top of both cylinders.
2. Power up 2"-3". You should hear air escaping around the caps. Repeat 3 - 4 times or until only oil is coming out of the caps.
3. Tighten the caps and lower the lift.

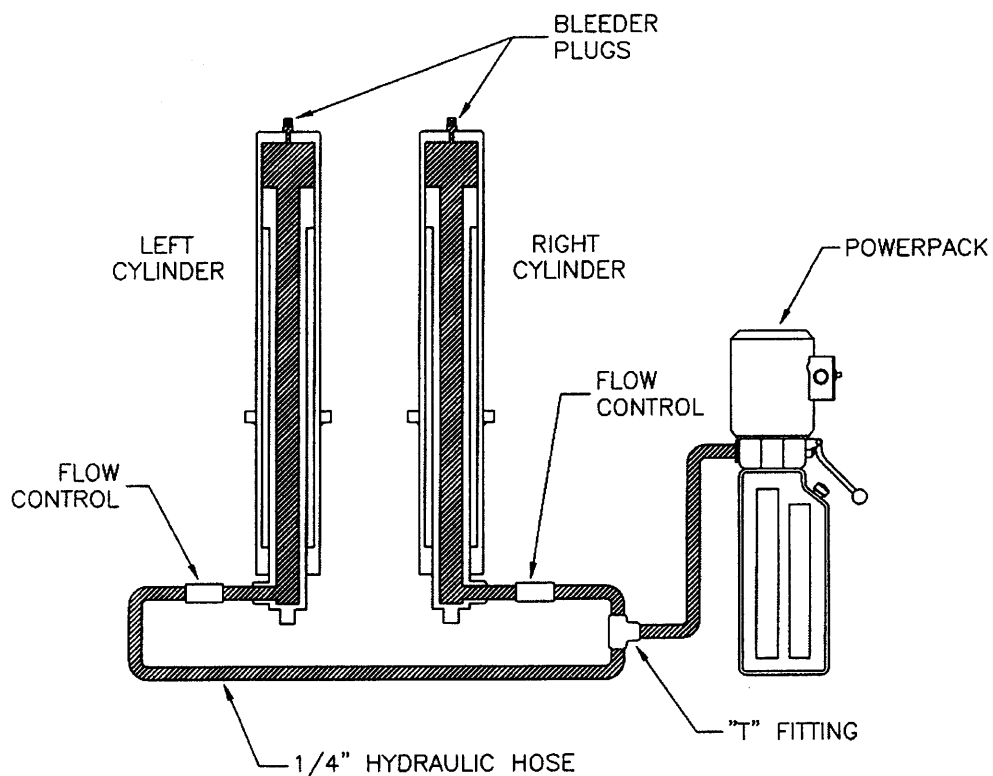

**Figure 13 – Hydraulic Schematic**

### 5.13 TOWER POSITIONING AND ANCHORING

**WARNING!** Failure to follow these instructions may cause an unsafe operating condition.

**WARNING!** Before proceeding with installation, review Section 4: Installation & Tools.

1. Using a 4ft. level on top of the crossmember, determine which column is higher. Refer to **Figure 14**.
2. Using a 2ft. level on the sides of the high column, ensure that the column is level in the vertical position (**Figure 15**). Use shims under the column baseplate to hold the column level. Ensure that the base plate is completely supported by shims where it does not contact the floor (**Figure 16**).

**WARNING!** Do not use more than  $\frac{1}{2}$ " (13mm) of shims. Anchor bolts supplied allow for a maximum of  $\frac{1}{2}$ " (13mm) of shim. If more than  $\frac{1}{2}$ " (13mm) of shims are required, **DO NOT** proceed with installation and contact Product Manufacturer / Supplier for further details.

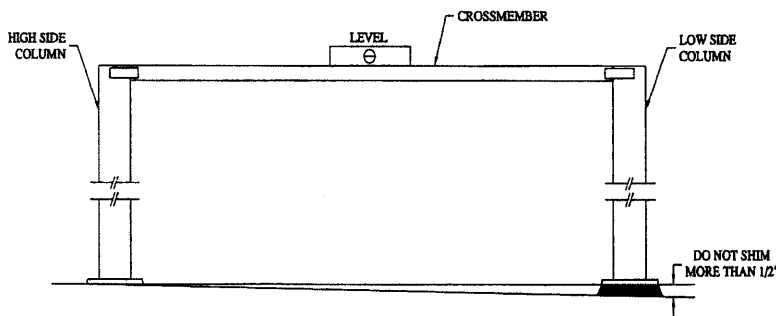

**Figure 14**

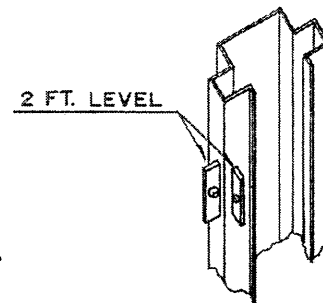

**Figure 15**

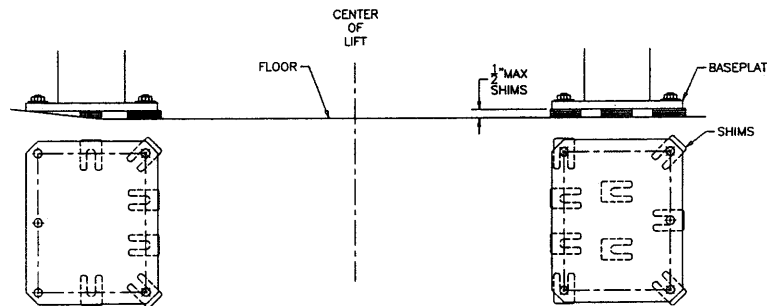

**Figure 16 - Shims**

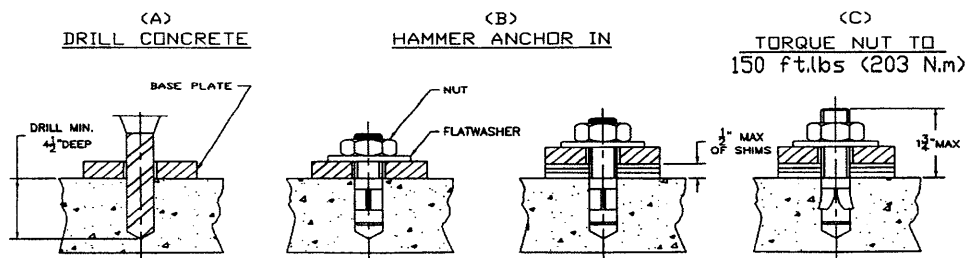

**Figure 17 - Anchor Bolts**

3. Refer to Bay Layout (**Figure 3**) to ensure that the column is still in the proper position. Using a rotary hammer drill with a 3/4" masonry drill bit, drill holes in the floor on the high side column using the tower baseplate as a template. Make sure that the 3/4" masonry drill is in good condition ( ).
4. Carefully clean out drilling dust from the anchor holes. Hammer in the anchor bolts (**Figure 17**). Hand tighten all anchor bolts.
5. Reconfirm that the column is level front to rear and side to side (**Figure 15**). Add or remove shims as required.
6. Torque all anchor bolts to 150 ft-lbs. (203 Nm), continually checking that the column is level as you proceed. If anchor bolts do not tighten to 150 ft-lbs. OR project more than 1 3/4" above the concrete surface (**figure 17**), the concrete MUST be replaced by an appropriate concrete pad. (*Consult Product Manufacturer / Supplier for further details*).

#### **5.14 SHIMMING OF THE REMAINING TOWER**

1. Using a 4ft. level on top of the crossmember (**Figure 14**) and a 2ft. level on the low side column (**Figure 15**), shim underneath the baseplate until the crossmember and column are level. Ensure that the baseplate is completely supported by shims where it does not contact the floor (**Figure 16**).

**WARNING!** *Do not use more than 1/2" (13mm) of shims. Anchor bolts supplied allow for a maximum of 1/2" (13mm) of shim. If more than 1/2" (13mm) of shims are required, DO NOT proceed with installation and contact Product Manufacturer / Supplier for further details.*

2. Refer to Bay Layout (**Figure 3**) to ensure that the column is still in the proper position. Using a rotary hammer drill with a 3/4" masonry drill bit, drill holes in the floor on the low side column using the tower baseplate as a template. Make sure that the 3/4" masonry drill is in good condition (**Figure 17**).
3. Carefully clean out drilling dust from the anchor holes. Hammer in the anchor bolts (**Figure 17**). Hand tighten all anchor bolts.
4. Reconfirm that the column is level front to rear and side to side (**Figure 15**). Add or remove shims as required.
5. Torque all anchor bolts to 150 ft-lbs. (203 Nm), continually checking that the crossmember and column are level as you proceed. If anchor bolts do not tighten to 150 ft-lbs. OR project more than 1 3/4" above the concrete surface (**Figure 17**), the concrete MUST be replaced by an appropriate concrete pad. (*Consult Product Manufacturer / Supplier for further details*).
6. Verify that the entire lift is level both horizontally and vertically to ensure optimum lifting performance. **NOTE: Perform a monthly inspection and torque all anchor bolts to 150 ft-lbs. (203 Nm).**

## **6 LIFT MAINTENANCE GUIDLINES**

### **6.1 SAFETY INSTRUCTIONS**

Read operating and safety manuals before using any lift  
Do not operate a lift that has been damaged or is in disrepair  
Proper inspection and maintenance is necessary for safe operation

### **6.2 PERIODIC MAINTENANCE**

#### **DAILY:**

1. Check all hydraulic lines and fittings for pinch points , damage , cracks or leaks
2. Check all electrical wiring for pinch points , cracks or damage
3. Check all moving parts for uneven or excessive wear
4. Repair or replace all damaged , defective , worn or broken components immediately
5. Check the telescopic arms for movement. Clean any grease or oil from the lifting adapters
6. Raise and lower the lift at the beginning of each shift, without a vehicle on, to verify the lift is leveled and operating properly.

#### **WEEKLY:**

1. Check and adjust hydraulic level

#### **EVERY TWO MONTHS:**

1. Clean and re-grease slide block channels inside of both columns
2. Grease arm pins
3. Lubricate safety dogs and check safety release cable adjustment
4. Check arm restraints and lubricate
5. Check anchor bolts and re-torque if required

#### **EVERY FOUR MONTHS:**

1. Dismantle and clean inner arms
2. Lubricate cable pulleys
3. Check equalizing cable adjustment

#### **EVERY YEAR:**

1. Inspect lift as per Automotive Lift Operation, Inspection and Maintenance (ALOIM)

#### **EVERY TWO YEARS:**

1. Change hydraulic fluid

**LUBRICATION:**

- Where grease is required > multi-purpose lithium grease
- Where lubricating oil is required > multi-purpose SAE 30 lubricating oil
- Where hydraulic oil is required > ISO 32 10W - non detergent hydraulic oil

**NOTE: If lift locks while in the fully raised position this will indicate that the hydraulic system has not been inspected or maintained as recommended. This is a safety back-up system. If you are unclear call your local representative immediately.**

**7 SAFETY AWARENESS - AUTOMOTIVE LIFT INSTITUTE (ALI)**

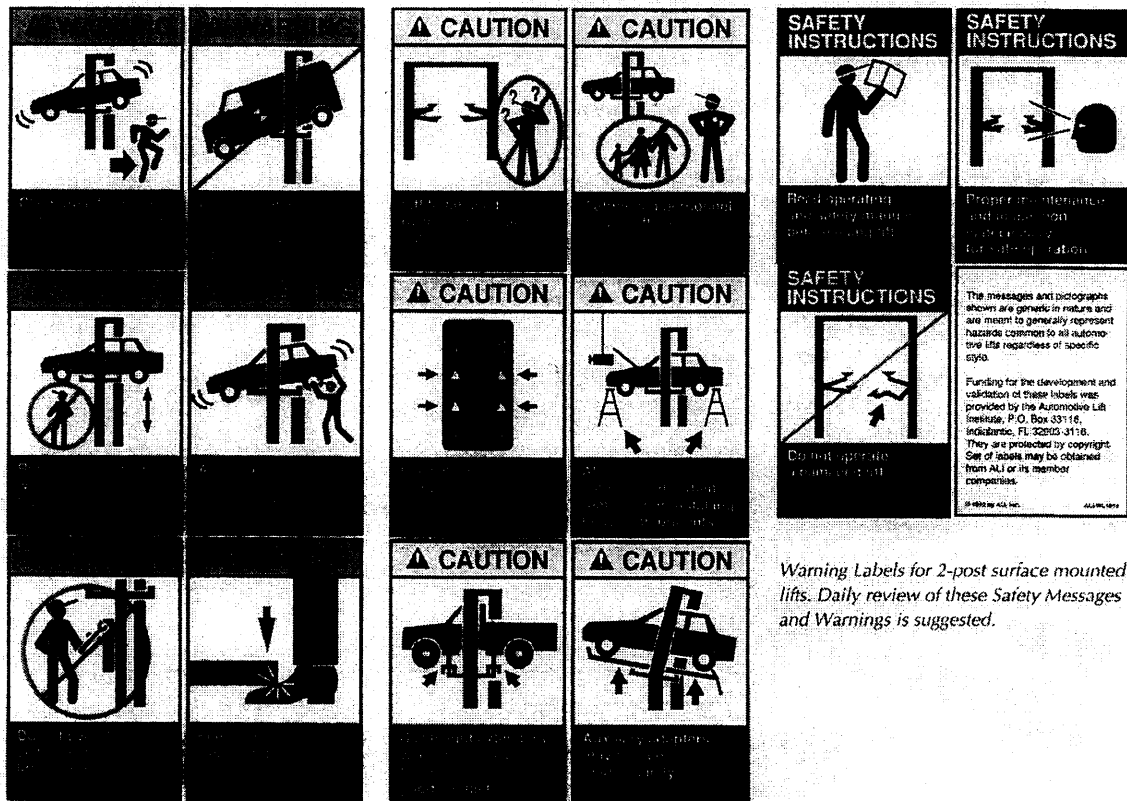

*Warning Labels for 2-post surface mounted lifts. Daily review of these Safety Messages and Warnings is suggested.*



# 8 PARTS MANUAL

## 8.1 LIFT ASSEMBLY

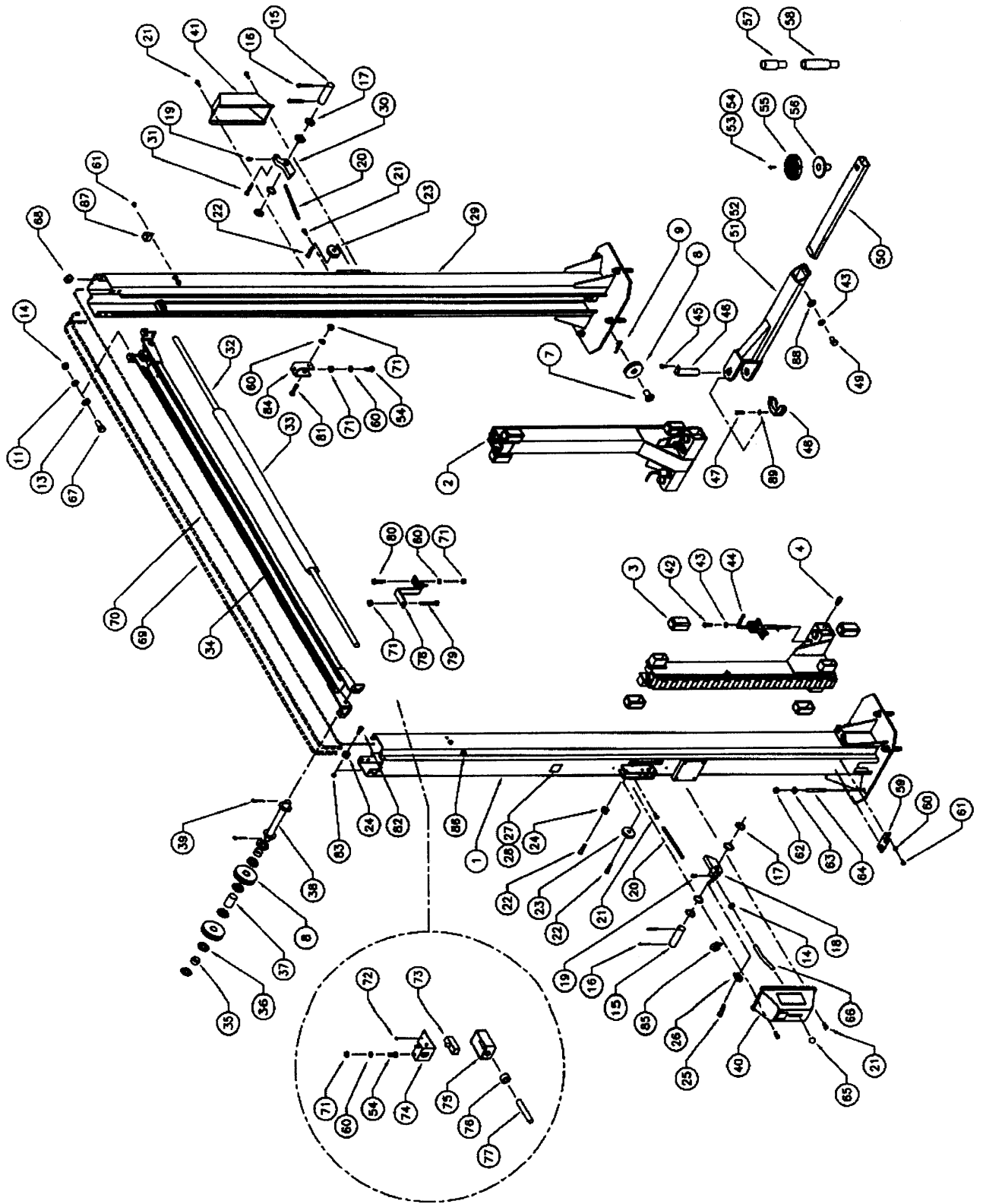

## 8.2 LIFT ASSEMBLY PARTS LIST

ITEM	QTY	DESCRIPTION	PART #
1	1	TOWER WELDMENT, POWER SIDE	4-0767
2	2	CARRIAGE WELDMENT	4-0766
3	8	GLIDE BEARING	2-0772
4	4	GREASE NIPPLE	6-0000
7	2	PIN, CABLE EQUALIZATION	1-1887
8	6	2-POST PULLEY	1-1898
9	2	HITCH PIN, 1/8" DIA	6-1841
11	8	LOCKWASHER, 1/2"ID	6-0059
13	8	FLAT WASHER, 1/2"ID SAE	6-0248
14	13	HEX NUT, 1/2"-13UNC	6-0035
15	2	SAFETY PIN	1-0938
16	4	COTTER PIN, 1/8"DIA. x 1"LG.	6-0267
17	8	FLAT WASHER, 51/64"ID x 1"OD x 1/16"THK.	6-0808
18	1	SAFETY DOG WELDMENT, POWER SIDE	2-1901
19	4	SELF TAPPING SCREW, #10 X 3/8" LG.	6-0169
20	2	SAFETY SPRING	1-1115
21	6	SELF TAPPING SCREW, #12 x 1/2"LG.	6-1134
22	3	SHOULDER BOLT, 3/8"DIA. x 1"LG.	6-0206
23	2	SAFETY PULLEY	1-0415
24	3	SAFETY CABLE PULLEY	1-1116
25	1	SHOULDER BOLT, 3/8" x 1 1/2" LG.	6-0801
26	1	THIMBLE, 5/32"	6-2074
27	1	CAPACITY DECAL	6-1767
28	1	SERIAL PLATE	6-1111
29	1	TOWER WELDMENT, SLAVE SIDE	4-0768
30	1	SAFETY DOG, SLAVE SIDE	2-0872
31	1	SHOULDER BOLT, 3/8"DIA. x 1 1/2"LG.	6-0801
32	1	ACTUATOR BAR	1-1439
33	1	FOAM GUARD	6-1404
34	1	CROSSMEMBER WELDMENT	2-1281
35	4	CROSSMEMBER PULLEY PIPE, 1/2"LG.	1-1623
36	16	FLAT WASHER, 3/4"ID	6-0738
37	2	CROSSMEMBER PULLEY PIPE, 1 3/4"LG.	1-1626
38	2	CROSSMEMBER PULLEY SHAFT	2-1251
39	4	COTTER PIN, 1/8"DIA. x 1 1/2"LG.	6-0978
40	1	SAFETY COVER cw/DECALS, POWER SIDE	0-0204
41	1	SAFETY COVER cw/DECALS, SLAVE SIDE	0-0203
42	8	SOCKET HEAD CAP SCREW, 3/8" X 1" LG.	6-2048
43	12	LOCKWASHER, 3/8" ID	6-0058
44	4	ARM LOCK ASSEMBLY	1-2038
45	4	HEX BOLT, 5/16"-18UNC x 3/4" LG.	6-0423
46	4	ARM PIN	2-1594
47	4	HEX BOLT, 5/16"-18UNC x 1 1/4" LG.	6-2059
48	4	ARM LOCK GEAR	1-2044
49	4	HEX BOLT, 3/8UNCx3/4"LG.	6-0030
50	4	INNER ARM WELDMENT	3-0761

ITEM	QTY	DESCRIPTION	PART #
51	4	OUTER ARM WELDMENT	3-0850
52	4	LOCKING ARM ASSEMBLY cw/ARM LOCK PIN	4-0950-6
53	4	STACK PAD ASSEMBLY	1-2045
54	7	HEX BOLT, 1/4"-20UNC x 3/4" LG.	6-0178
55	4	RUBBER PAD	6-2050
56	4	STACK PAD WELDMENT	1-2030
57	4	STACK PAD ADAPTER, 3"	1-1993
58	4	STACK PAD ADAPTER, 6"	2-1580
59	2	STACK PAD ADAPTER HOLDER	1-2012
60	10	LOCKWASHER, 1/4" ID	6-0056
61	10	ROUND HEAD SCREW, 1/4"-20UNC x 3/8" LG.	6-1353
62	10	HEX NUT, 3/4"-10UNC	6-0737
63	10	FLAT WASHER, 3/4"ID	6-0738
64	10	WEDGE ANCHOR, 3/4"-10UNC x 5 1/2"LG.	6-1379
65	1	PLASTIC KNOB	6-1135
66	1	SAFETY RELEASE HANDLE	1-1113
67	8	HEX BOLT, 1/2"-13UNC x 1 1/4" LG.	6-0046
68	3	RUBBER GROMMET	6-1507
69	2	EQUALIZING CABLE	1-1473
70	1	SAFETY RELEASE CABLE	1-2058
71	7	HEX HD. NUT 1/4"NC	6-0032
72	2	6/32 SCREW (ELECTRICAL BOX)	6-1466
73	1	MICROSWITCH	6-0916
74	1	LIMIT SWITCH MTG. BRACKET	2-1143
75	1	ELECTRICAL UTILITY BOX	6-1403
76	1	CABLE CONNECTOR	6-1133
77	1	ELEC. CABLE 12/3 x 117"LG.	6-1173
78	1	ACTUATOR EXTENSION	1-1379
79	1	HEX HD. BOLT 1/4"NC x 2"LG.	6-0741
80	2	HEX HD. BOLT 1/4"NC x 1 1/4"LG.	6-0027
81	1	HEX HD. BOLT 1/4"NC x 1 1/2"LG.	6-0205
82	2	SHOULDER BOLT, 3/8"DIA. x 5/8"LG.	6-0069
83	2	HEX NUT, 5/16"-18UNC	6-0294
84	1	ACTUATOR MTG. BRACKET	1-1378
85	2	WIRE ROPE CLIP, 1/16"	6-2060
86	3	ELECTRICAL CABLE CLIP, 5/8" ID	6-1759
87	6	TUBE CLAMP, 1/2"	6-0536
88	4	FLATWASHER, 3/8"ID SAE	6-0062
89	8	FLATWASHER, 5/16"ID	6-0295

### 8.3 HYDRAULIC SYSTEM

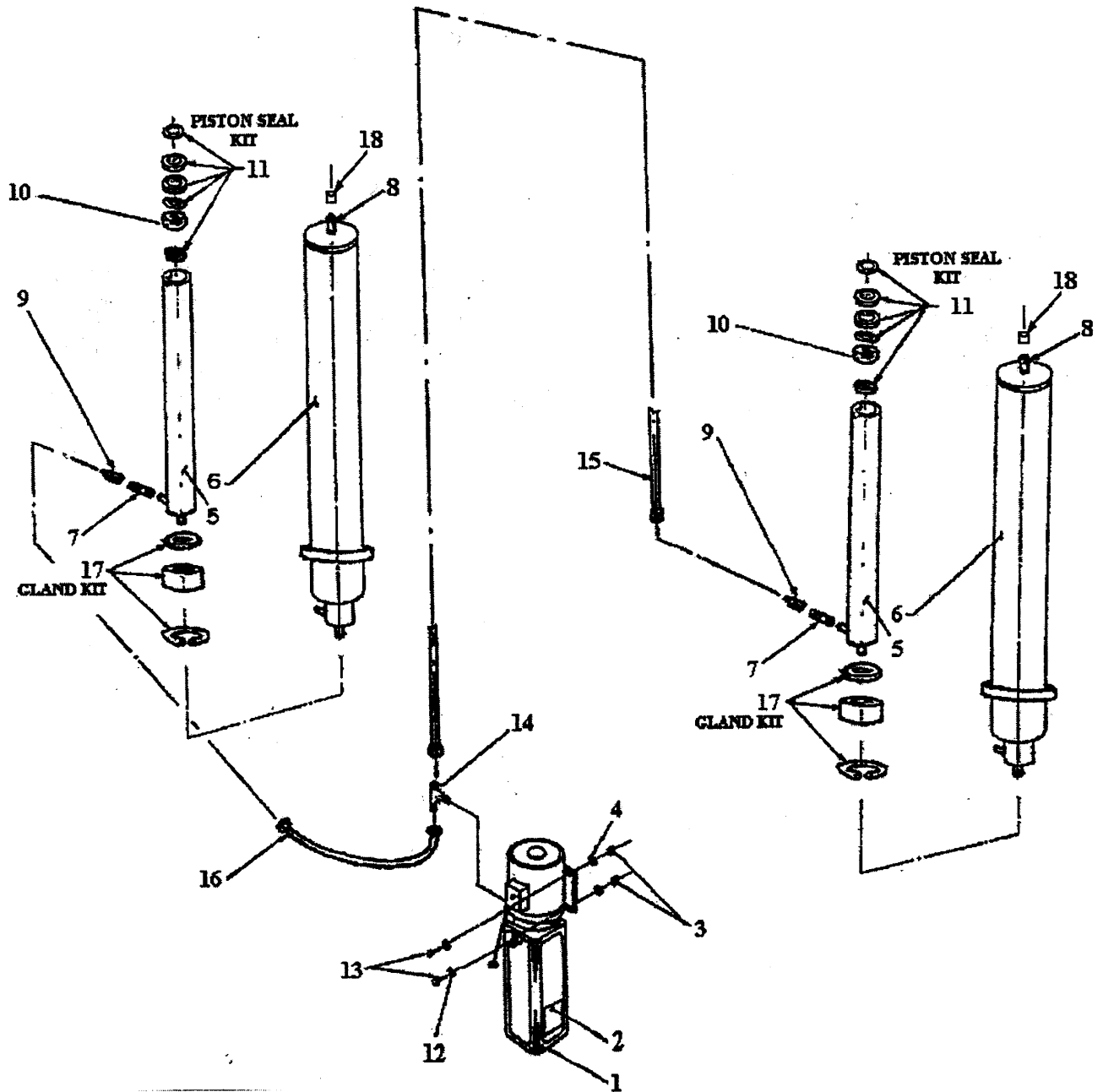

## 8.4 HYDRAULIC SYSTEM PARTS LIST

ITEM	QTY	DESCRIPTION	PART #
1	1	POWER PACK, 208-230V, 1PH	6-2055
		POWER PACK, 208-230V, 3PH	6-2665
2	1	"LIFT OPERATION" DECAL	6-1639
3	4	HEX NUT, 5/16"-18UNC	6-0294
4	4	LOCK WASHER, 5/16" I.D.	6-0674
5	2	PISTON ROD 1 1/4" O.D. x 1/4" W x 72 11/16 LG.	1-1469
6	2	CYLINDER TUBE MACHINED	1-1465
7	2	MALE NIPPLE, 1/4" NPT	6-2059
8	2	1/8" NPT TO 1/4" JIC	6-0280
9	2	FLOW CONTROL	6-1510
10	2	PISTON	1-1467
11	2	PISTON SEAL KIT	0-0337
12	4	FLAT WASHER, 5/16" I.D.	6-0295
13	4	HEX BOLT, 5/16"-18UNC x 1" LG.	6-0293
14	1	BRANCH TEE	6-1506
15	1	HYDRAULIC HOSE (LONG)	1-2040
16	1	HYDRAULIC HOSE (SHORT)	2-1230
17	2	GLAND KIT	0-0338
18	2	1/4" JIC CAP	6-1884
	*	CYLINDER ASSEMBLY (INCL. FLOW CONTROL)	3-0621
<i>3 PH POWERPACK INCLUDES THE FOLLOWING (NOT SHOWN)</i>			
*	1	CONTACTOR BOX (REMOVE JUMPER & WIRE FOR 3PH)	6-1575
*	1	CONTACTOR BRACKET	2-1130
*	1	COVER PLATE	1-1369
*	2	HEX BOLT, 1/4"-NC x 1" LG	6-0008
*	4	LOCKWASHER, 1/4"	6-0056
*	2	HEX NUT, 1/4"-NC	6-0032
*	2	STRAIN RELIEF	6-0094
*	2FT	CABLE, 14/4	8-0287

### 8.5 POWER PACK:

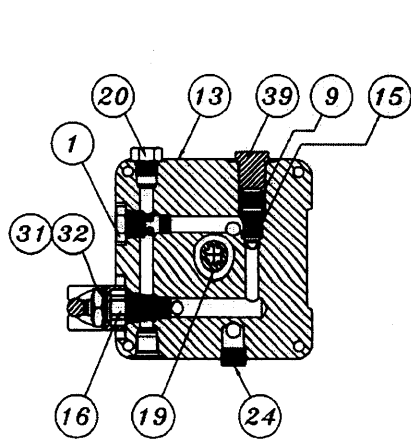
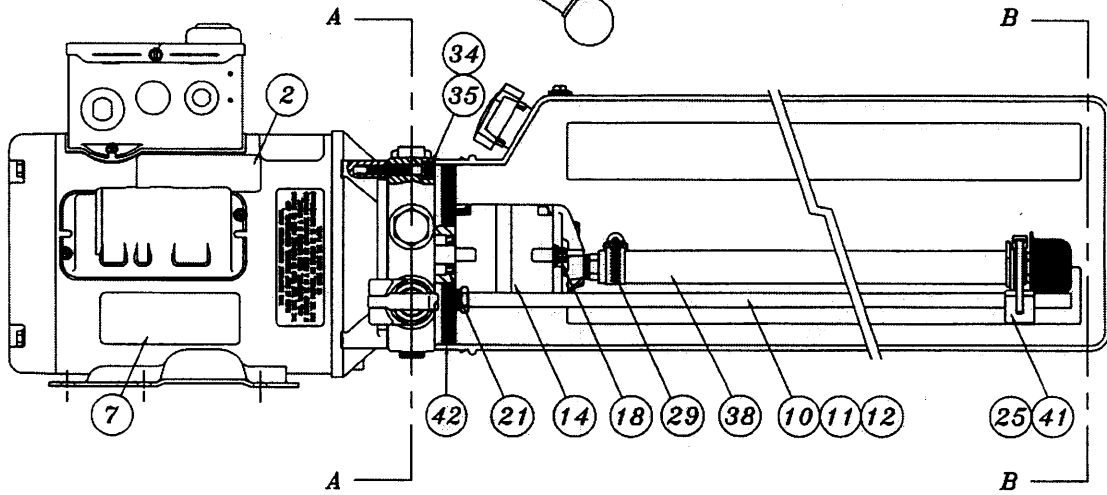
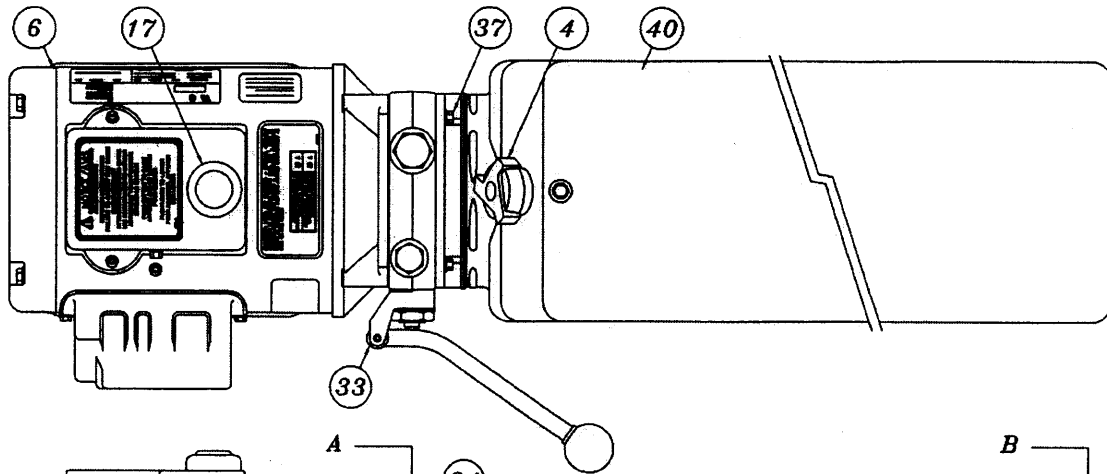

A-A

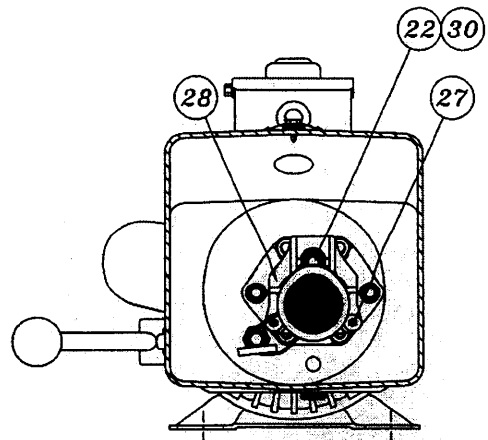

B-B

## 8.6 POWER PACK PARTS LIST:

#6-2055 (AB-1381) 208-230V/1PH/60Hz

#6-2665 (AD-1044) 208-230V/1PH/60Hz

ITEM	QTY.	DESCRIPTION	PART #
1	1	VALVE CARTRIDGE CHECK	6-1087
2	1	LABEL INSTALLATION AUTOHOIST	6-2136
4	1	BREATHER CAP & BLADDER	6-1376
6	1	MOTOR AC 208-230V. 2HP/1PH/60Hz, BLK	6-2139
	1	MOTOR AC 208-230V. 2HP/3PH/60Hz, BLK	6-1079
7	1	LABEL WARNING AUTOHOIST	6-2149
9	1	SPRING 0.480" x 0.063" x 0.42" COMP	6-2151
10	1	RETURN HOSE 3/8" OD x 21.5"	6-2152
11	1	COMPRESSION TUBE NUT	6-2153
12	1	COMPRESSION TUBE SLEEVE	6-2154
13	1	ENDHEAD UNIVERSAL AUTOHOIST	6-2155
14	1	PUMPASSY 2.5 CC/REV. SHORT SPLINE	6-1958
15	1	RELIEF ASSEMBLY FIXED 190 BAR	6-1319
16	1	VALVE CARTRIDGE RELEASE MANUAL	6-0880
17	1	WIRING ASSEMBLY AC 1PH FENNER	6-2156
18	2	BOLT 5/16"-24 x 3.00" TORX G8	6-1090
19	1	COUPLING SAE 9T-20/40 1.260"	6-0774
20	1	PLUMBING PLUG 9/16" SAE	6-2157
21	1	SEAL SHAFT 0.500" x 1.00" x 0.25"	6-2158
22	1	WASHER 0.338" x 0.625" x 0.060" STEEL	6-2159
24	1	PLUMBING PLUG 3/8" NPT	6-2161
25	1	PLUMBING MAGNET	6-2162
27	2	SCREW TAPTITE M6 x 1.0 12MM TORX	6-2164
28	1	COVER ASSY SUCTION	6-2165
29	1	PLUMBING CLAMP HOSE ADJ. INLET	6-2166
30	1	BOLT 5/16"-18 x 1.00" SHCS	6-1392
31	1	NUT 3/4"-16 x 1" HEX x 0.250" STEEL	6-2167
32	1	WASHER 3/4" INT. TOOTH LOCK	6-2168
33	1	BRACKET - HANDLE ASSY REL BLACK	6-0776
34	4	BOLT M6 x 1.0 35MM SOC HD	6-2169
35	4	WASHER 1/4" LOCK HI-COLLAR	6-2170
37	4	BOLT #12-24 x 0.50" HEX WSHRHD	6-1091
38	1	PLUMBING ASSY INLET 17.24 (3)	6-0786
39	1	RELIEF VALVE CAP ASSEMBLY	6-1089
40	1	TANK PLASTIC 6.7 OS 22.50" BLK	6-1399
41	1	CABLE TIE 8" LONG WHITE	6-1846
42	1	O-RING 2-348 BUNA	6-0875

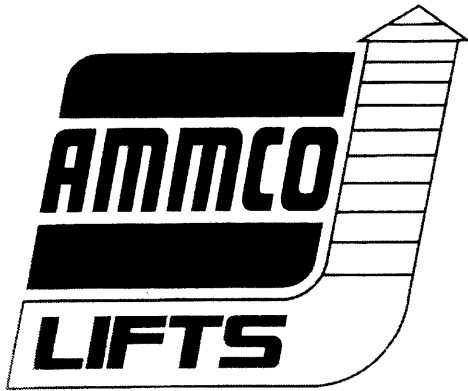

# INSTALLATION and OPERATION MANUAL

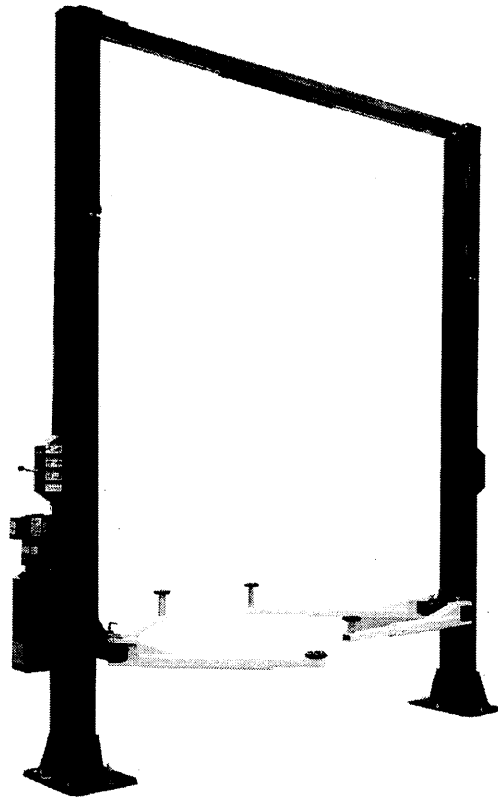

**10K SYMMETRIC 2 POST**  
**S21SS**   - R/B/M, 1/3 (12FT)  
**S21SX**   - R/B/M, 1/3 (14FT)

**READ and SAVE THIS  
INSTRUCTION MANUAL**



# TABLE OF CONTENTS

	PAGE
<b>1 SAFETY AND OPERATING INSTRUCTIONS .....</b>	<b>1</b>
<b>2 SPECIFICATIONS.....</b>	<b>2</b>
<b>3 CONTENTS.....</b>	<b>3</b>
<b>4 INSTALLATION REQUIREMENTS AND TOOLS .....</b>	<b>3</b>
<b>5 INSTALLATION INSTRUCTIONS .....</b>	<b>4</b>
5.1 UNPACKING PROCEDURE .....	4
5.2 BAY LAYOUT.....	5
5.3 SAFETY SHUT-OFF BAR INSTALLATION .....	5
5.4 SAFETY SHUT-OFF BAR ADJUSTMENT .....	6
5.5 TOWER POSITIONING AND SETUP .....	7
5.6 ROUTING OF EQUALIZATION CABLE.....	8
5.7 ARM INSTALLATION .....	9
5.8 ARM LOCKS INSTALLATION .....	10
5.9 SAFETY RELEASE CABLE ROUTING AND ADJUSTMENT .....	11
5.10 POWER PACK INSTALLATION.....	12
5.11 HYDRAULIC SYSTEM INSTALLATION .....	13
5.12 HYDRAULIC SYSTEM BLEEDING .....	14
5.13 TOWER POSITIONING AND ANCHORING .....	15
5.14 SHIMMING OF THE REMAINING TOWER.....	16
<b>6 LIFT MAINTENANCE GUIDLINES .....</b>	<b>17</b>
6.1 SAFETY INSTRUCTIONS.....	17
6.2 PERIODIC MAINTENANCE.....	17
<b>7 SAFETY AWARENESS - AUTOMOTIVE LIFT INSTITUTE (ALI).....</b>	<b>18</b>
<b>8 PARTS MANUAL .....</b>	<b>19</b>
8.1 LIFT ASSEMBLY .....	19
8.2 LIFT ASSEMBLY PARTS LIST .....	20
8.3 HYDRAULIC SYSTEM .....	22
8.4 HYDRAULIC SYSTEM PARTS LIST .....	23
8.5 POWER PACK:.....	24
8.6 POWER PACK PARTS LIST:.....	25

## 1 SAFETY AND OPERATING INSTRUCTIONS

1. Read all instructions.
2. Inspect lift daily. Do not operate if it malfunctions or problems have been encountered.
3. Never attempt to overload the lift. The manufacturer's rated capacity is shown on the identification label on the power side column. Do not override the operating controls or the warranty will be void.
4. Only trained and authorized personnel should operate the lift. Do not allow customers or bystanders to operate the lift or be in the lift area.
5. Position the lift support pads to contact the vehicle manufacturer's recommended lifting points. Raise the lift until the pads contact the vehicle. Check pads for secure contact with the vehicle, then raise the lift to the desired working height.
6. Some pickup trucks may require an optional truck adapter to clear running boards or other accessories. **NOTE:** Always use all 4 arms to raise and support vehicle.
7. **Caution! Never work under the lift unless the mechanical safety locks are engaged.**
8. Note that the removal or installation of some vehicle parts may cause a critical load shift in the center of gravity and may cause the vehicle to become unstable. Refer to the vehicle manufacturer's service manual for recommended procedures.
9. Always keep the lift area free of obstruction and debris. Grease and oil spills should always be cleaned up immediately.
10. Never raise vehicle with passengers inside.
11. Before lowering check area for any obstructions.
12. Before driving vehicle between the towers, position the arms to the drive-through position to ensure unobstructed clearance. Do not hit or run over arms as this could damage the lift and/or vehicle.
13. Before removing the vehicle from the lift area, position the arms to the drive-through position to prevent damage to the lift and /or vehicle.
14. Care must be taken as burns can occur from touching hot parts.
15. Do not operate equipment with a damaged cord or if the equipment has been dropped or damaged – until a qualified serviceman has examined it.
16. Do not let cord hang over table, bench or counter or come in contact with hot manifolds or moving fan blades.
17. If an extension cord is necessary, a cord with a current rating of two or more than that of the equipment should be used. Cords rated for less current than the equipment may overheat. Care should be taken to arrange the cord so that it will not be tripped over or pulled.
18. Always unplug the equipment from electrical outlet when not in use. Never use the cord to pull the plug from the outlet. Grasp plug and pull to disconnect.

## 2 SPECIFICATIONS

Capacity:  
 Overall Width:  
 Width Between Columns:  
 Drive-Thru Width:  
 Overall Height (12ft Model):  
 Overall Height (14ft Model):  
 Under Bar Clearance (12ft Model):  
 Under Bar Clearance (14ft Model):  
 Height to Lowered Lift Pads:  
 Height to Lift Pad (3" Adapter):  
 Height to Lift Pad (6" Adapter):  
 Retracted Arm Length:  
 Extended Arm Length:  
 Maximum Lifting Height (6" Adapter):  
 Lift Time:  
 Power Requirements (Standard):

10000 lbs.	4500 kg
146"	3708 mm
120"	3048 mm
109"	2769 mm
144"	3658 mm
168"	4267 mm
140"	3556 mm
164"	4166 mm
4 1/2"	114 mm
7 1/2"	191 mm
10 1/2"	267 mm
35 1/4"	895 mm
53 1/2"	1359 mm
79 1/4"	2013 mm
45 seconds	
230 Volts AC, 1 Ph., 60Hz.	

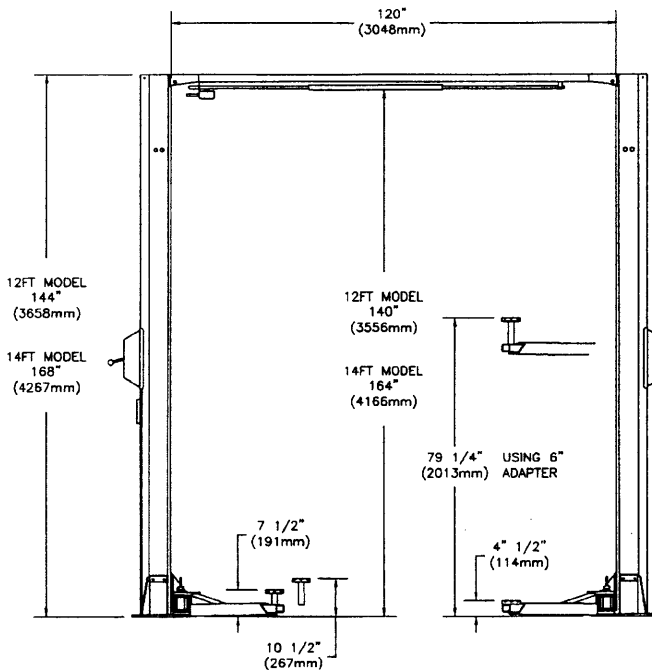

**Figure 1 – Front View**

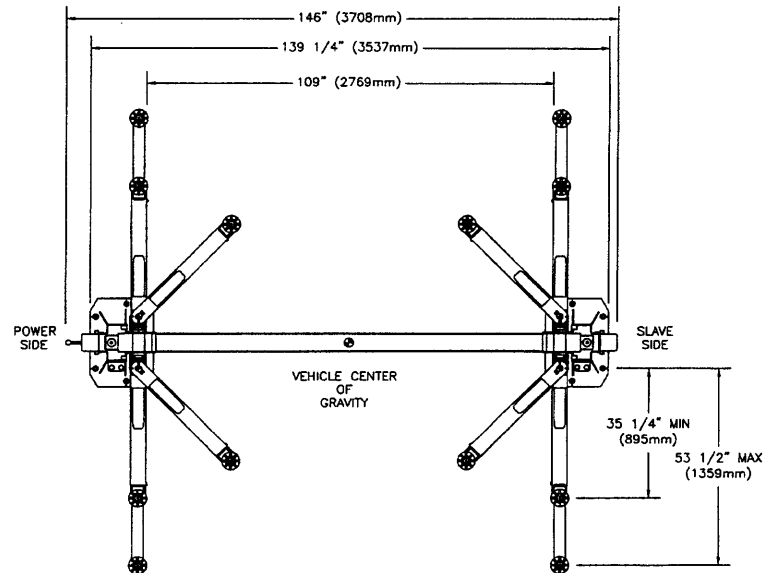

**Figure 2 – Top View**

### 3 CONTENTS

The complete lift is contained in two (2) packages:

1. The **main structural components** are packed in a steel frame.
2. The remaining parts are packed in an **accessory box**.

#### **Main Structural Components includes:**

- 1pc. - Power side tower and carriage assembly
- 1pc. - Slave side tower and carriage assembly
- 1pc. - Crossmember
- 1pc. - Actuator Bar w/ foam

#### **Accessory box contents:**

- 4pcs. - Locking Arm Assembly w/arm pins
- 2pcs. - Safety Covers w/Decals
- 1pc. - Hardware Package w/Packing List
- 1pc. - Actuator Extension
- 1pc. - Actuator Mounting Bracket
- 1pc. - Power Pack
- 4pc. - Arm Locks
- 4pc. - Stack Pad Assembly
- 4pc. - Stack Pad Adapter (3")
- 4pc. - Stack Pad Adapter (6")
- 1pc. - Safety Release Cable
- 1pc. - Hydraulic Hose (Long)
- 1pc. - Hydraulic Hose (Short)
- 2pcs. - Equalizing Cable w/Hex Nuts
- 1pc. - ALI manual "Lifting It Right"
- 1pc. - Automotive Lift Safety Tips
- 1pc. - Automotive Lift, Operation, Inspection and Maintenance manual
- 1pc. - "ALI" Quick Reference Guide
- 1pc. - Owner's manual
- 1pc. - Safety Shut-off Microswitch Assembly (Components)

### 4 INSTALLATION REQUIREMENTS AND TOOLS

**IMPORTANT: It is the user's responsibility to provide a satisfactory installation area for the lift. Lifts should only be installed on level concrete floors with a minimum thickness of five (5) inches or 130 mm. Concrete must have a minimum strength of 4000 psi or 30 MPa and should be aged thirty (30) days prior to installation. Please consult the architect, contractor or engineer if doubt exists as to the strength and feasibility of the floor to enable proper lift installation and operation.**

**It is the user's responsibility to provide all wiring for electrical hook-up prior to installation and to insure that the electrical installation conforms to local building codes. Where required, it is the user's responsibility to provide an electrical isolation switch located in close proximity to the lift that will enable emergency stop capability and isolate electrical power from the lift for any servicing requirements.**

## **Tools Required:**

- a. 16ft. Measuring Tape
- b. Chalk Line
- c. Rotary Hammer Drill
- d. 3/4" diameter Masonry Drill Bit
- e. Hammer
- f. SAE Wrenches and Ratchet Set
- g. 2ft. Level
- h. 4ft. Level
- i. Crow Bar
- j. 12ft. Step Ladder
- k. Side Cutters
- l. Screwdrivers
- m. 4" x 4" Wooden Blocks (for unpacking)

## **5 INSTALLATION INSTRUCTIONS**

When the lift arrives on site:

- Read the owner's manual and make sure the installation instructions are fully understood.
- Check for any freight damages.
- Check the contents of the accessory and hardware boxes to make sure no parts are missing.
- Gather all the tools listed above.

### **5.1 UNPACKING PROCEDURE**

1. **Important!** Place the main structural components on wooden blocks so that the steel shipping frames can be removed.
2. Remove the plastic wrapping.
3. Remove the crossmember, and the actuator bar.
4. Unbolt the steel shipping frames.
5. Lay each tower on the floor with the carriage side up.
6. Check the installation area for obstructions. (Lights, Heating Ducts, Ceiling, Floor Drains, etc.)
7. Prepare the bay by selecting the location of the lift relative to the walls. Clear the installation area of all packaging materials to avoid trip hazards. Draw a chalk line on the floor to represent the centerline of the bay then draw a second chalk line at 90° for locating the lift towers. Refer to **Figure 3**.

## 5.2 BAY LAYOUT

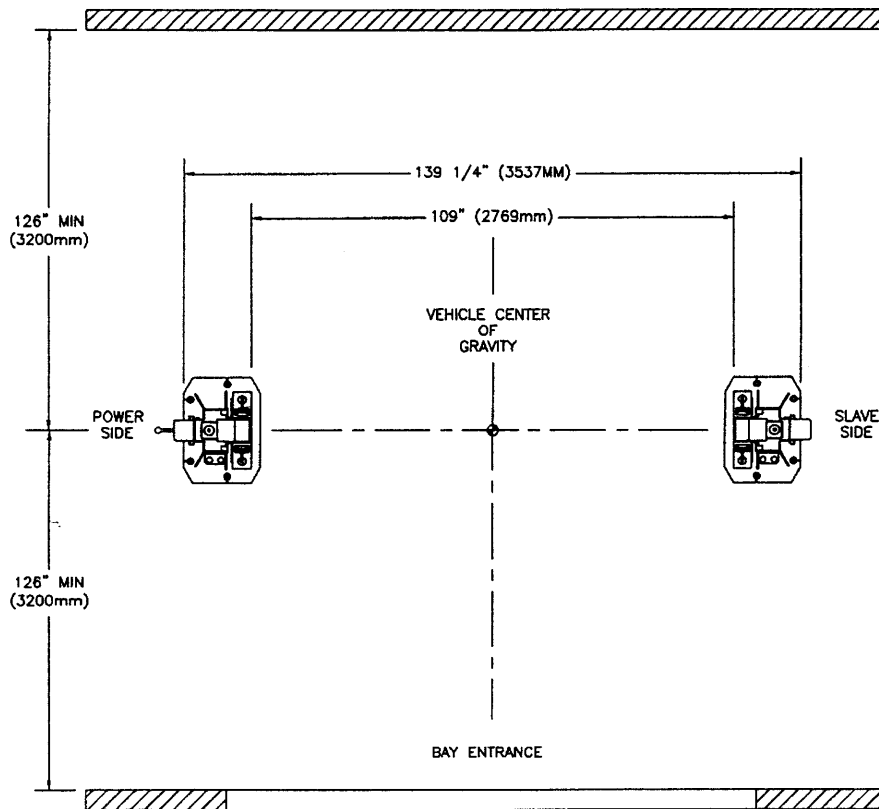

Figure 3 – Bay Layout

## 5.3 SAFETY SHUT-OFF BAR INSTALLATION

**Note:** The safety shut off will disconnect the power to the power pack when an obstruction touches the padded bar or the carriages reach their maximum height. The safety shut off switch is factory pre-wired. Refer to Figure 4.

Note: This procedure can be done on the floor.

1. Attach the Actuator Mounting Bracket (1-1378) to the crossmember using one 1/4"-NC x 3/4" lg. hex head bolt (6-0178), one 1/4" ID lockwasher (6-0056), and one 1/4" NC hex nut (6-0032).
2. Attach the Actuator Bar to the Actuator Mounting Bracket using one 1/4" NC x 1 1/2" lg. hex head bolt (6-0205), one 1/4" ID lockwasher (6-0056), and one 1/4" NC hex nut (6-0032).
3. Slide Safety Shut-Off Microswitch Assembly over the open end of actuator bar and bolt the assembly to the crossmember using two (2) 1/4" NC x 3/4" lg. hex head bolts (6-0178), two (2) 1/4" ID lockwashers (6-0056), and two (2) 1/4" NC hex nut (6-0032).

4. Install the 1/4" NC x 2" lg. hex bolt (6-0741) into the actuator extension (1-2143 12ft Model, 1-1823 14ft Model) then attach the 1/4" NC hex nut (6-0032) from the other side to hold the bolt in place.

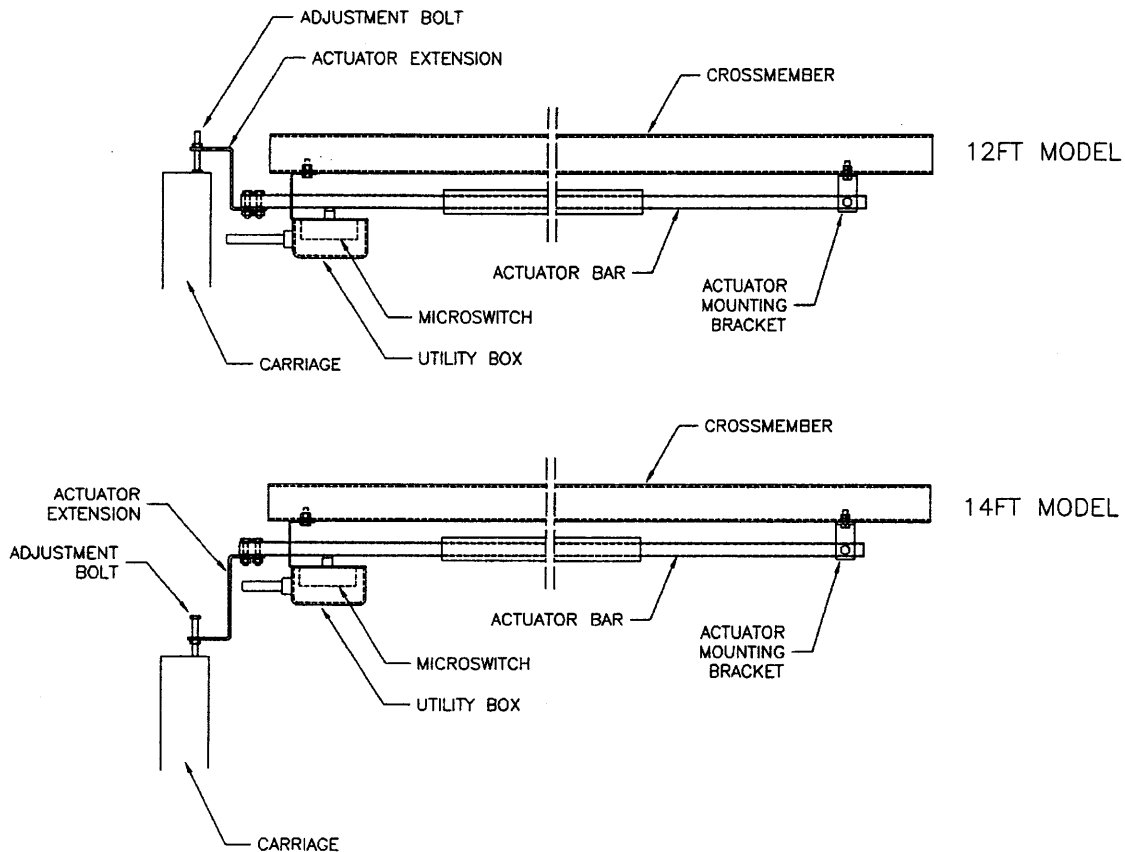

**Figure 4 – Safety Shut-Off Bar Installation**

#### 5.4 SAFETY SHUT-OFF BAR ADJUSTMENT

**Note: This procedure must be done last. Refer to Figure 4.**

1. When the lift is fully installed, leveled and operational, extend the carriages to their full upper limit.
2. Lower the carriages about 1/4" to 1/2".
3. Bolt the Actuator Extension (1-2143 12ft Model, 1-1823 14ft Model) onto the open end of actuator bar using two (2) 1/4" NC x 1 1/4" lg. hex head bolts (6-0027), two (2) 1/4" ID lockwashers (6-0056), and two (2) 1/4" NC hex nuts (6-0032).
4. Adjust the 1/4" NC x 2" lg. hex bolt so that the end of the bolt is in contact with the carriage. Tighten the 1/4" NC hex nut on the bolt.

## 5.5 TOWER POSITIONING AND SETUP

1. Locate the power side and slave side towers and position them as shown in **Figure 3**. Double check all the dimensions in the layout.
2. Using a stepladder, install the crossmember using eight (8)  $\frac{1}{2}$ "-16UNC x  $1\frac{1}{4}$ " lg. hex head bolts, eight (8)  $\frac{1}{2}$ " ID lock washers, eight (8)  $\frac{1}{2}$ " hex nuts and eight (8)  $\frac{1}{2}$ " flat washers. See **Figure 5**.
3. Check the towers to make sure they are located, and positioned in the correct location. Refer to **Figure 3**.

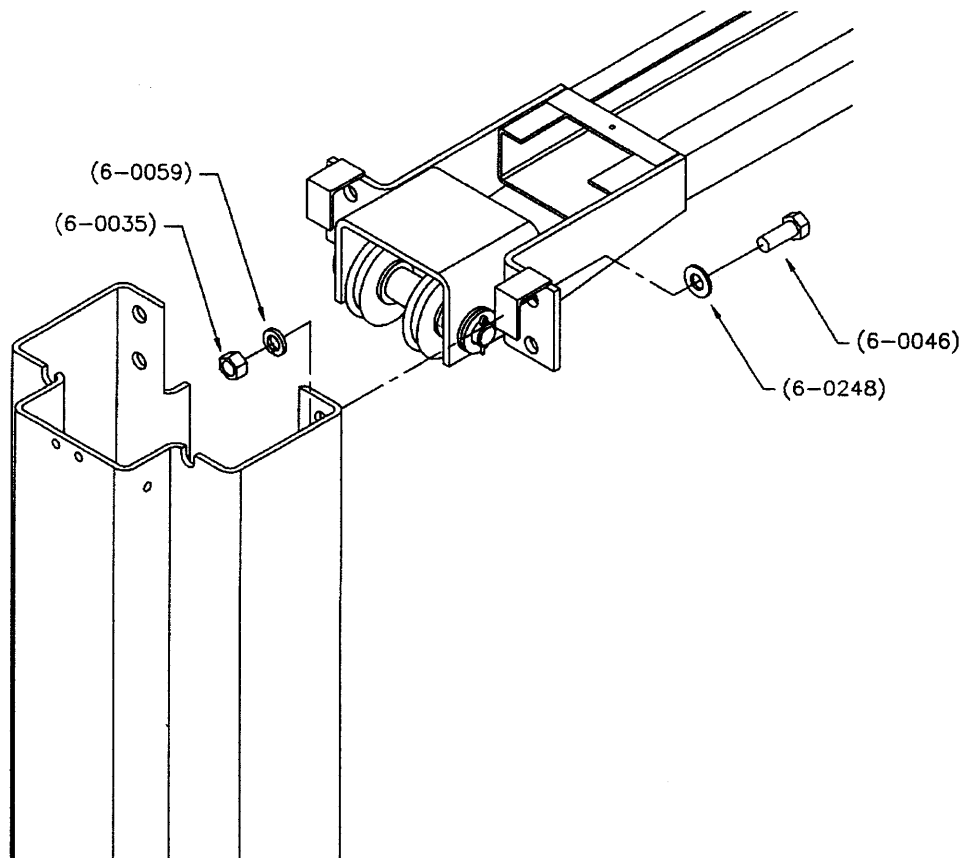

**Figure 5 – Crossmember Assembly**



## 5.6 ROUTING OF EQUALIZATION CABLE

Use **Figure 6** to route the equalization cables.

1. Remove the carriage covers and manually lift the carriages to the first safety latch.
2. Remove the  $\frac{1}{2}$ "-13 UNC nylon locknuts off the equalization cables and retain for use later.
3. Route the equalization cables as shown in Figure 6. Using the first cable, insert the shorter threaded stud up through the  $\frac{9}{16}$ " diameter hole in the bottom of the carriage and feed it up through the opening in the top of the carriage. Run the nylon locknut onto the shorter stud so that  $\frac{1}{2}$ " of threads extend past the top of the locknut and pull the cable back into the carriage. Route the opposite end of the cable around the sheave at the base of the column and up around the sheave at the top of the column. Run the cable across the crossmember and around the sheave at the top of the other column. Insert the longer threaded stud into the  $\frac{9}{16}$ " diameter hole in the top of the carriage.
4. Use a wrench to hold the top of the threaded stud to prevent it from rotating. Tighten the locknut onto the longer threaded stud enough to remove all visible cable slack. Repeat steps 2 to 4 for the other equalizing cable (**Step A**).
5. Using two wrenches, tighten the locknut at the top of the carriage approximately  $1\frac{1}{2}$ " (**Step B**) past the point where visible cable slack has been removed. Repeat for the other cable.

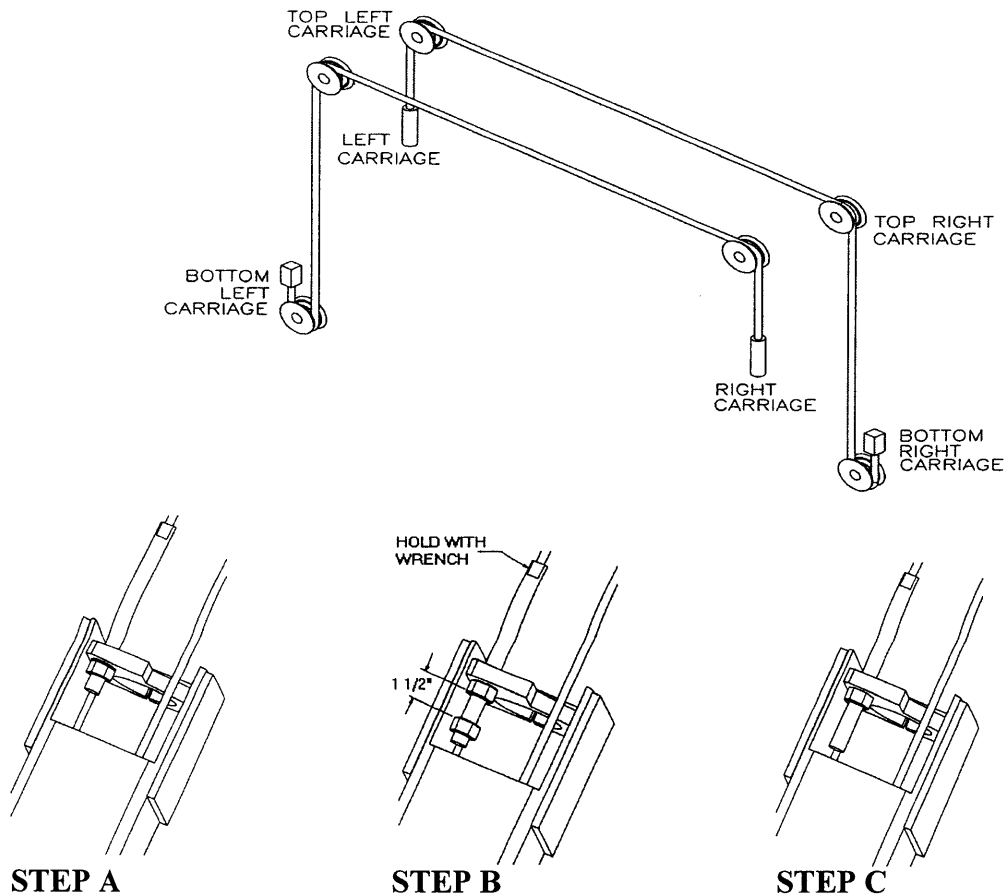
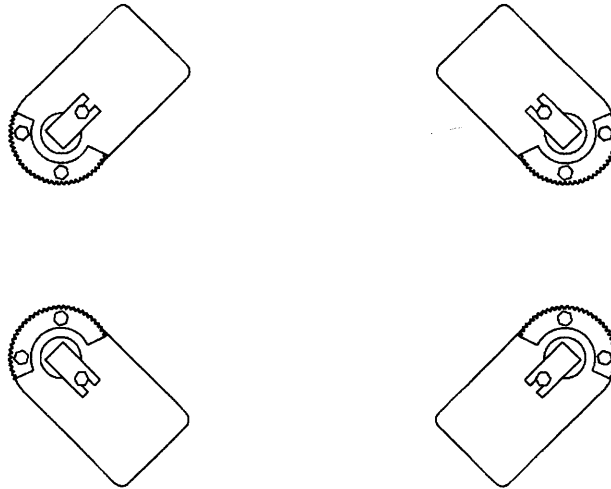

**Figure 6 – Equalization Cables**

## 5.7 ARM INSTALLATION

1. Remove the four (4) 5/16"-18UNC x 3/4"LG. hex head bolts that are holding the arm pins to the arm. Install the arms on the carriages.
2. Grease and insert arm pins. Align the notch on each arm pin with the tapped hole on the arm, and using the 5/16"-18UNC x 3/4"LG. hex head bolt removed in previous step, reinstall and tighten securely.
3. Using two (2) 5/16"-18UNC x 1 1/4" LG. hex head bolts and two (2) 5/16" flatwashers, attach each arm lock gear as shown in **Figure 7**.

FRONT



REAR

**Figure 7 – Arm Installation**

## 5.8 ARM LOCKS INSTALLATION

Using two (2) 3/8"-16UNC x 1" LG. socket head cap screws, and two (2) 3/8" ID lockwashers, install the arm lock assemblies as shown in **Figure 8**. Before tightening completely, make sure that the arm lock has full contact with the arm lock gear by pushing it firmly against the arm.

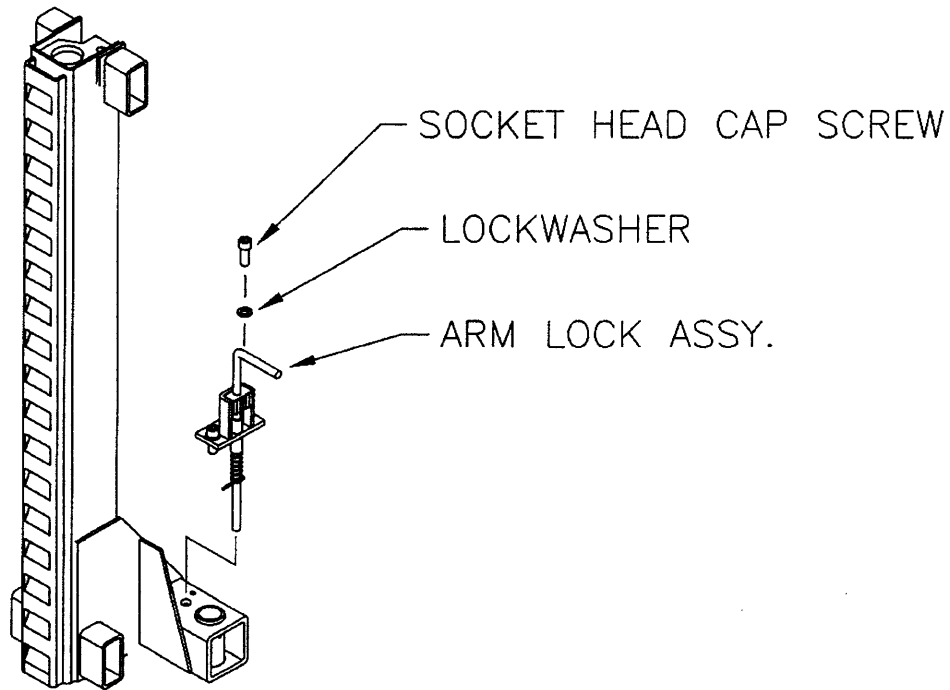
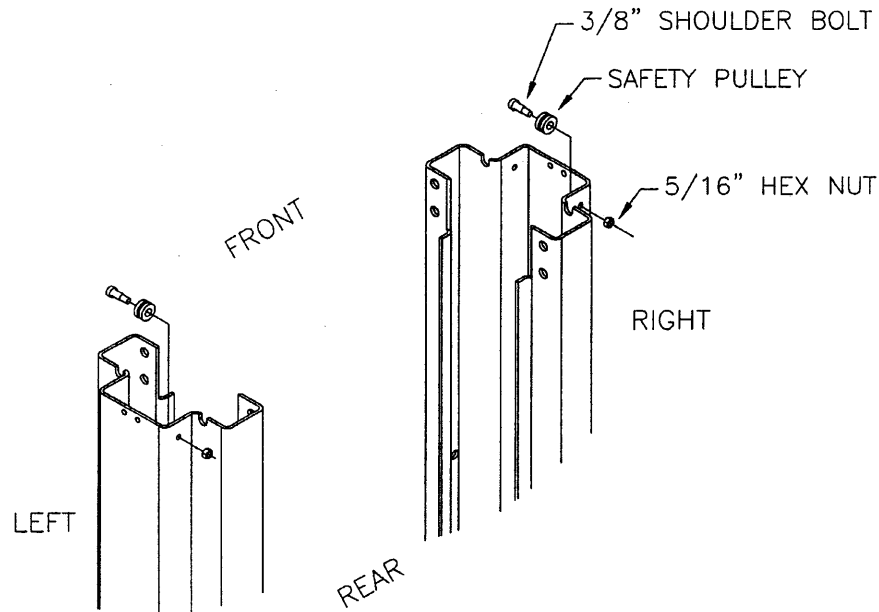

**Figure 8 – Arm Lock Installation**

## 5.9 SAFETY RELEASE CABLE ROUTING AND ADJUSTMENT

The mechanical safety automatically engages. To release the mechanical safety, you must first raise the lift approximately 2", then pull the safety release lever down. This disengages the power side safety dog and activates the safety cable to release the slave side safety dog.

1. Install the safety pulley on each tower as shown in
2. **Figure 9.** Attach the safety pulley to the tower using the 3/8" x 5/8" LG. shoulder bolt, 5/16" lockwasher and 5/16" hex nut.



**Figure 9 - Safety Release Pulley Installation**

3. Refer to **Figure 10** for safety release cable routing. The end of the cable that has a collar attaches to the slave side tower. The free end is fixed to the power side tower using two (2) wire rope clips.
4. Install the safety release handle onto the power side safety dog.
5. Start routing the safety release cable from the slave side of crossmember. Feed the cable over the small pulley, then guide the cable down along the inside of the slave side tower. Pull the cable out through the opening in the back of the tower near the safety dog.
6. Guide the cable up under the large pulley towards the end of the safety dog. Remove the 3/8" x 1 1/2" shoulder bolt from the safety dog. Feed the shoulder bolt through the collar of the safety release cable and then replace the shoulder bolt securely to the safety dog.
7. Repeat step 2 for the power side tower.

8. Guide the cable up under the large pulley and then over the small pulley towards the safety dog as shown in Figure 10. Wrap the cable around the thimble (attached to the safety dog with a 3/8" x 1 1/2" lg. shoulder bolt) and then clamp it using two (2) wire rope clips. Do not tighten fully at this stage.
9. Adjust the cable length so that both safety dogs travel from full engagement position to full release position when the safety release handle is pulled. **Tighten both wire rope clips firmly when adjustment is completed.**

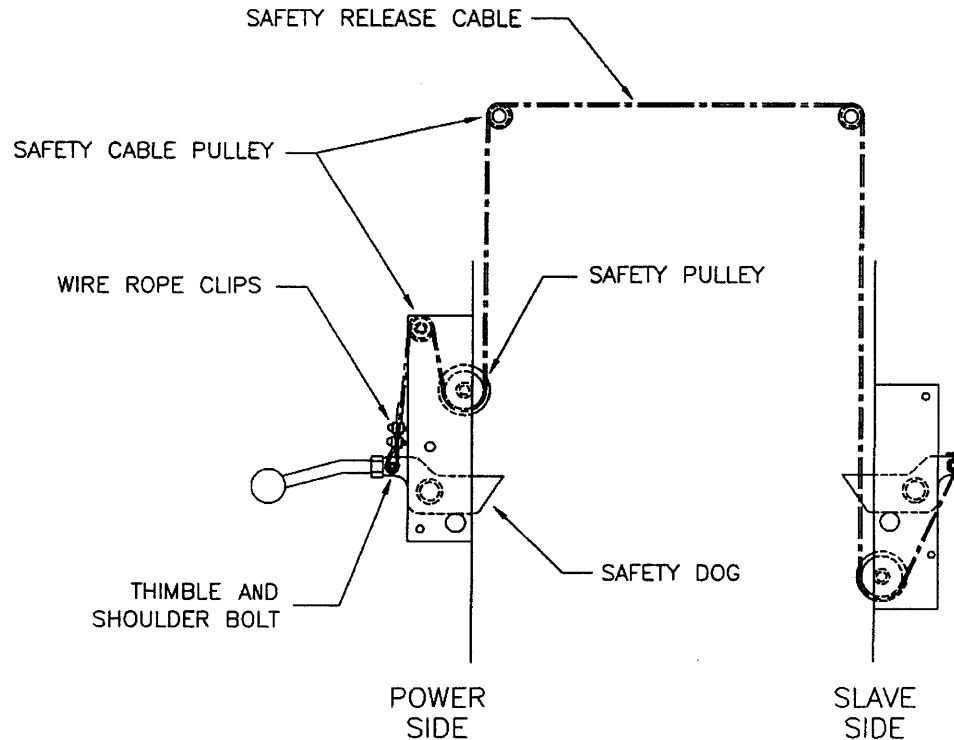

**Figure 10 – Safety Release Cable Routing and Adjustment**

## 5.10 POWER PACK INSTALLATION

1. Remove the **red** plastic cap located at the rear of the power pack, and install the "T" fitting located in the hardware kit.
2. Bolt power pack to the mounting bracket on the power side tower using four (4) 5/16"-18UNC x 1"LG. hex head bolts, four (4) 5/16" ID lock washers, four (4) 5/16" ID flat washers and four (4) 5/16"-18UNC hex nuts. Do not tighten.
3. Remove the filler cap from the powerpack and fill the reservoir with approximately 4.5 Gal. (18L) of ISO32 hydraulic oil (10 wt. hydraulic oil). Remove breather screw when filling and replace when full.
4. A **certified electrician** must connect the 230Volt/1Ph power to the motor. The electrical diagram is provided, refer to **Figure 12**.

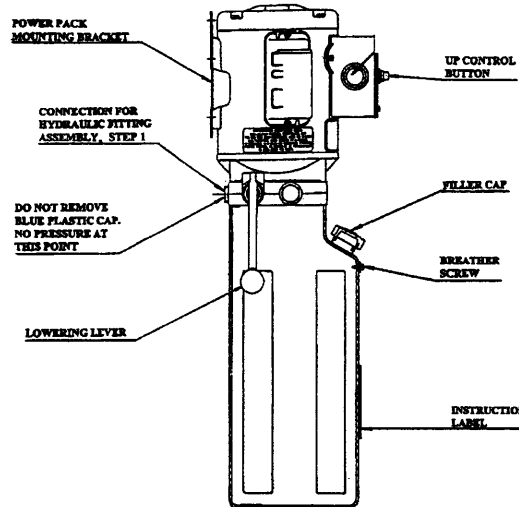

**Figure 11 – Powerpack Details**

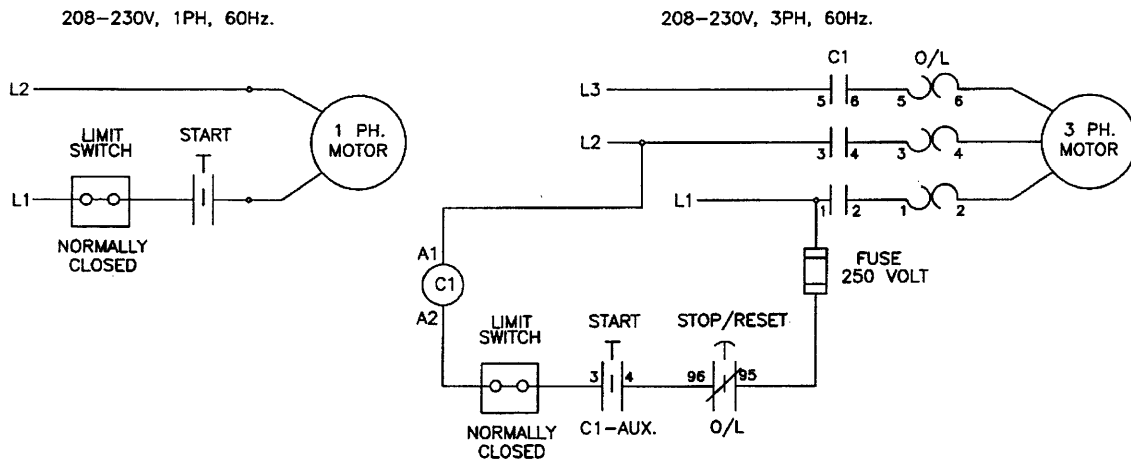

**Figure 12 – Electrical Diagram**

## 5.11 HYDRAULIC SYSTEM INSTALLATION

### REFER TO HYDRAULIC PARTS LIST

1. Connect the 45° end of the long hose to the “T” fitting on the powerpack.
2. Connect the 45° end of the short hose to the other end of the “T” fitting.
3. Remove the plastic cap from the bottom of the power side cylinder and connect the 90° end of the short hose to the cylinder.
4. Loop the hydraulic hose up the power side tower, across the overhead and down the slave side tower. Place rubber grommets (item 68 in the lift assembly) between the tower and the hose at the top of each tower.

5. Remove the plastic cap from the bottom of the slave side cylinder and connect the 90° end of the long hose to the cylinder.
6. The long hydraulic hose must be fixed to the towers using six (6) hose clamps. Screw the hose clamps into the weld nuts on the towers using 1/4"-20UNC x 3/8"lg. round head screws.
7. The long hydraulic hose must be fixed to the crossmember using two (2) hose clamps. Screw the hose clamps into the crossmember using #10 x 3/8" lg. self threading screws.

## 5.12 HYDRAULIC SYSTEM BLEEDING

1. Crack the caps located at the top of both cylinders.
2. Power up 2"-3". You should hear air escaping around the caps. Repeat 3 - 4 times or until only oil is coming out of the caps.
3. Tighten the caps and lower the lift.

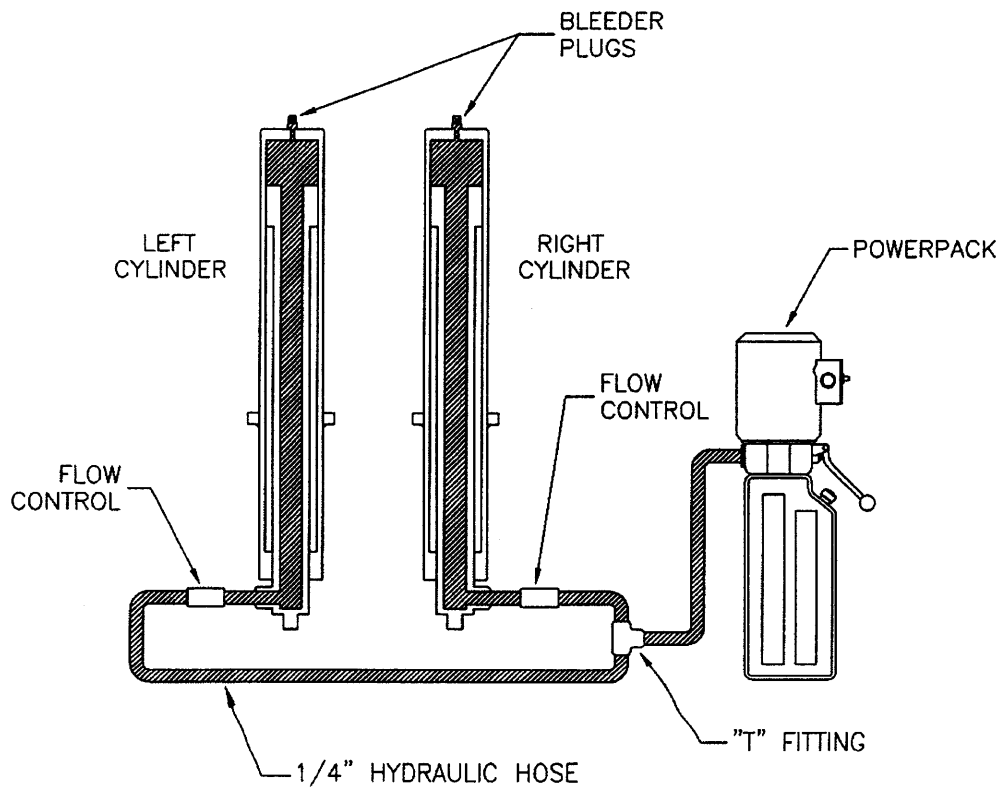

**Figure 13 – Hydraulic Schematic**

## 5.13 TOWER POSITIONING AND ANCHORING

**WARNING!** Failure to follow these instructions may cause an unsafe operating condition.

**WARNING!** Before proceeding with installation, review Section 4: Installation & Tools.

1. Using a 4ft. level on top of the crossmember, determine which column is higher. Refer to **Figure 14**.
2. Using a 2ft. level on the sides of the high column, ensure that the column is level in the vertical position (**Figure 15**). Use shims under the column baseplate to hold the column level. Ensure that the base plate is completely supported by shims where it does not contact the floor (**Figure 16**).

**WARNING!** Do not use more than  $\frac{1}{2}$ " (13mm) of shims. Anchor bolts supplied allow for a maximum of  $\frac{1}{2}$ " (13mm) of shim. If more than  $\frac{1}{2}$ " (13mm) of shims are required, **DO NOT** proceed with installation and contact Product Manufacturer / Supplier for further details.

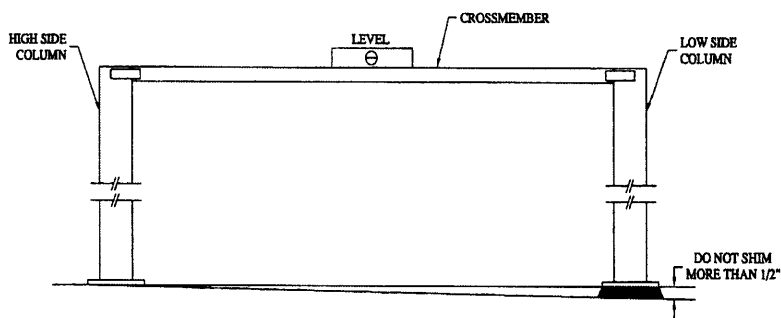

**Figure 14**

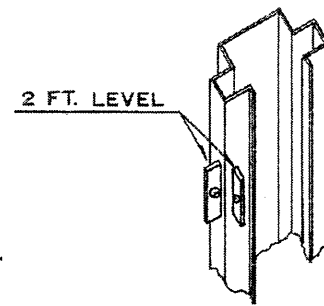

**Figure 15**

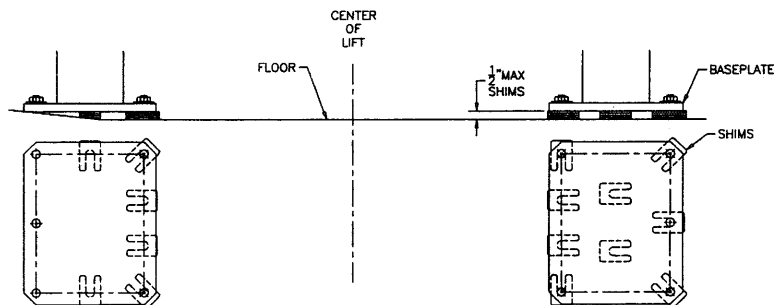

**Figure 16 - Shims**

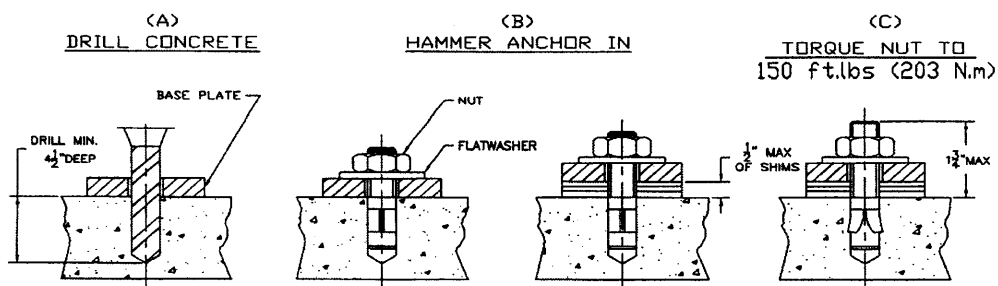

**Figure 17 – Anchor Bolts**



3. Refer to Bay Layout (**Figure 3**) to ensure that the column is still in the proper position. Using a rotary hammer drill with a 3/4" masonry drill bit, drill holes in the floor on the high side column using the tower baseplate as a template. Make sure that the 3/4" masonry drill is in good condition (**Figure 17**).
4. Carefully clean out drilling dust from the anchor holes. Hammer in the anchor bolts (**Figure 17**). Hand tighten all anchor bolts.
5. Reconfirm that the column is level front to rear and side to side (**Figure 15**). Add or remove shims as required.
6. Torque all anchor bolts to 150 ft-lbs. (203 Nm), continually checking that the column is level as you proceed. If anchor bolts do not tighten to 150 ft-lbs. OR project more than 1 3/4" above the concrete surface (**Figure 17**), the concrete MUST be replaced by an appropriate concrete pad. (*Consult Product Manufacturer / Supplier for further details*).

#### **5.14 SHIMMING OF THE REMAINING TOWER**

1. Using a 4ft. level on top of the crossmember (**Figure 14**) and a 2ft. level on the low side column (**Figure 15**), shim underneath the baseplate until the crossmember and column are level. Ensure that the baseplate is completely supported by shims where it does not contact the floor (**Figure 16**).

**WARNING!** *Do not use more than 1/2" (13mm) of shims. Anchor bolts supplied allow for a maximum of 1/2" (13mm) of shim. If more than 1/2" (13mm) of shims are required, DO NOT proceed with installation and contact Product Manufacturer / Supplier for further details.*

2. Refer to Bay Layout (**Figure 3**) to ensure that the column is still in the proper position. Using a rotary hammer drill with a 3/4" masonry drill bit, drill holes in the floor on the low side column using the tower baseplate as a template. Make sure that the 3/4" masonry drill is in good condition (**Figure 17**).
3. Carefully clean out drilling dust from the anchor holes. Hammer in the anchor bolts (**Figure 17**). Hand tighten all anchor bolts.
4. Reconfirm that the column is level front to rear and side to side (**Figure 15**). Add or remove shims as required.
5. Torque all anchor bolts to 150 ft-lbs. (203 Nm), continually checking that the crossmember and column are level as you proceed. If anchor bolts do not tighten to 150 ft-lbs. OR project more than 1 3/4" above the concrete surface (**Figure 17**), the concrete MUST be replaced by an appropriate concrete pad. (*Consult Product Manufacturer / Supplier for further details*).
6. Verify that the entire lift is level both horizontally and vertically to ensure optimum lifting performance. **NOTE: Perform a monthly inspection and torque all anchor bolts to 150 ft-lbs. (203 Nm).**

## **6 LIFT MAINTENANCE GUIDLINES**

### **6.1 SAFETY INSTRUCTIONS**

Read operating and safety manuals before using any lift  
Do not operate a lift that has been damaged or is in disrepair  
Proper inspection and maintenance is necessary for safe operation

### **6.2 PERIODIC MAINTENANCE**

#### **DAILY:**

1. Check all hydraulic lines and fittings for pinch points , damage , cracks or leaks
2. Check all electrical wiring for pinch points , cracks or damage
3. Check all moving parts for uneven or excessive wear
4. Repair or replace all damaged , defective , worn or broken components immediately
5. Check the telescopic arms for movement. Clean any grease or oil from the lifting adapters
6. Raise and lower the lift at the beginning of each shift, without a vehicle on, to verify the lift is leveled and operating properly.

#### **WEEKLY:**

1. Check and adjust hydraulic level

#### **EVERY TWO MONTHS:**

1. Clean and re-grease slide block channels inside of both columns
2. Grease arm pins
3. Lubricate safety dogs and check safety release cable adjustment
4. Check arm restraints and lubricate
5. Check anchor bolts and re-torque if required

#### **EVERY FOUR MONTHS:**

1. Dismantle and clean inner arms
2. Lubricate cable pulleys
3. Check equalizing cable adjustment

#### **EVERY YEAR:**

1. Inspect lift as per Automotive Lift Operation, Inspection and Maintenance (ALOIM)

#### **EVERY TWO YEARS:**

1. Change hydraulic fluid

**LUBRICATION:**

- Where grease is required > multi-purpose lithium grease
- Where lubricating oil is required > multi-purpose SAE 30 lubricating oil
- Where hydraulic oil is required > ISO 32 10W - non detergent hydraulic oil

**NOTE: If lift locks while in the fully raised position this will indicate that the hydraulic system has not been inspected or maintained as recommended. This is a safety back-up system. If you are unclear call your local representative immediately.**

**7 SAFETY AWARENESS - AUTOMOTIVE LIFT INSTITUTE (ALI)**

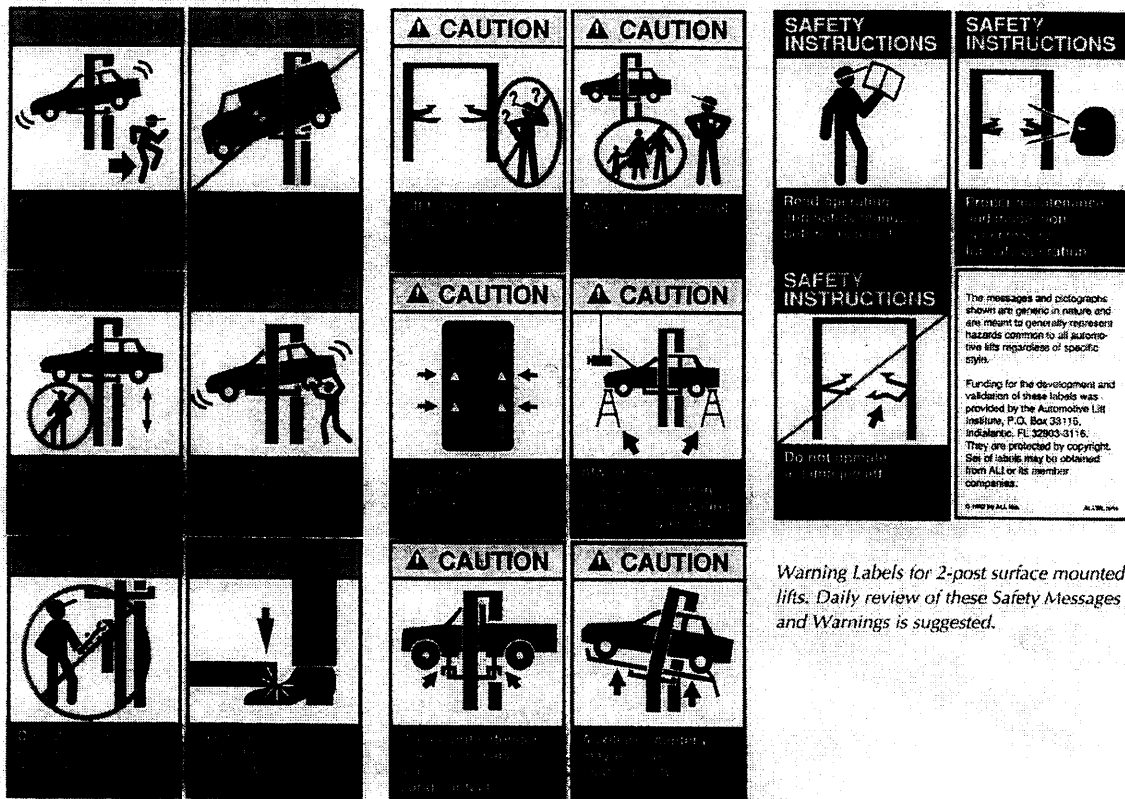

*Warning Labels for 2-post surface mounted lifts. Daily review of these Safety Messages and Warnings is suggested.*

# 8 PARTS MANUAL

## 8.1 LIFT ASSEMBLY

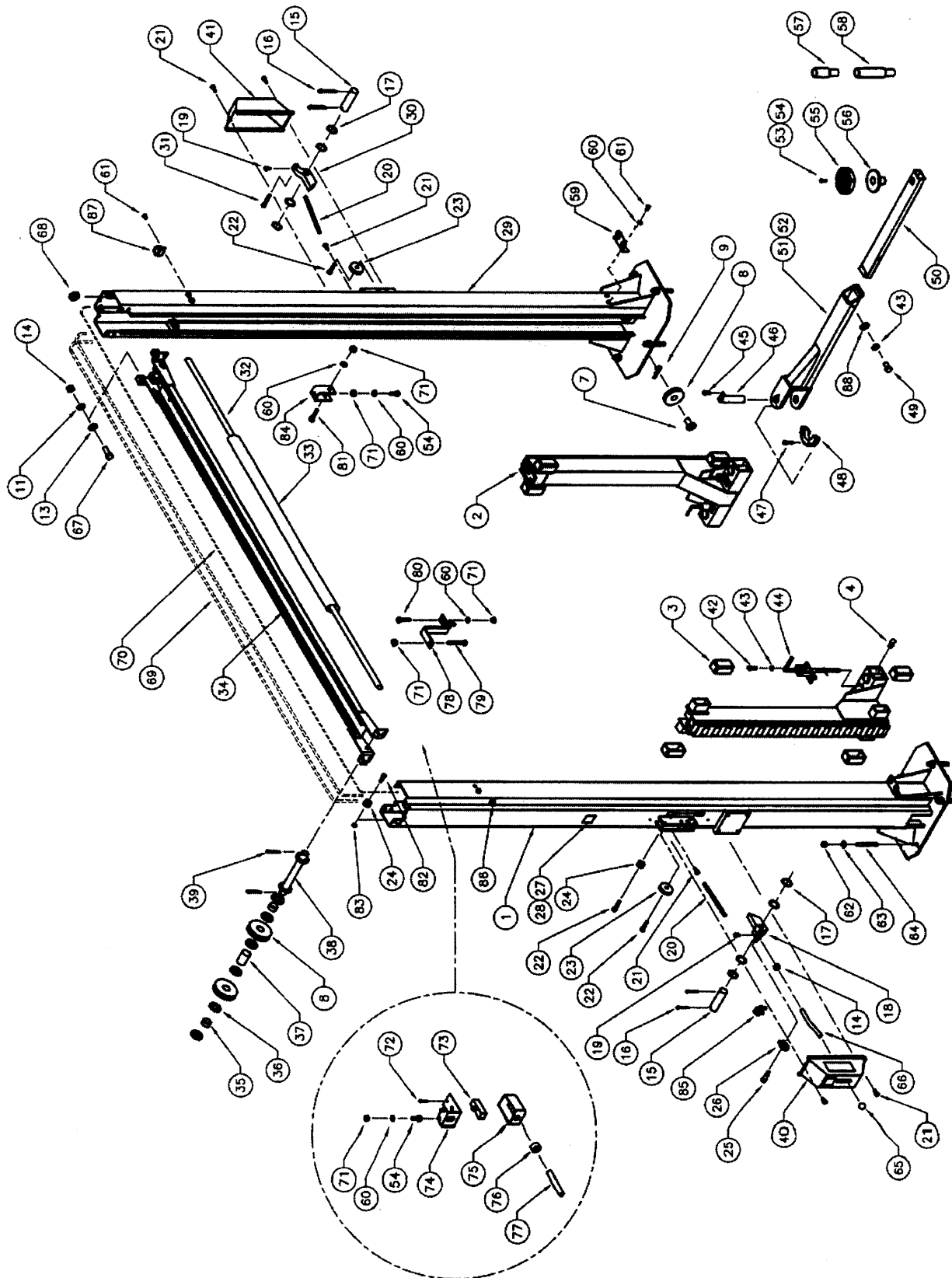

## 8.2 LIFT ASSEMBLY PARTS LIST

ITEM	QTY	DESCRIPTION	PART #
1	1	TOWER WELDMENT, POWER SIDE - 12FT MODEL	4-0755
	1	TOWER WELDMENT, POWER SIDE - 14FT MODEL	4-0752
2	2	CARRIAGE WELDMENT	4-0754
3	8	GLIDE BEARING	2-0772
4	4	GREASE NIPPLE	6-0000
7	2	PIN, CABLE EQUALIZATION	1-1887
8	6	2-POST PULLEY	1-1898
9	2	HITCH PIN, 1/8" DIA	6-1841
11	8	LOCKWASHER, 1/2"ID	6-0059
13	8	FLAT WASHER, 1/2"ID SAE	6-0248
14	13	HEX NUT, 1/2"-13UNC	6-0035
15	2	SAFETY PIN	1-0938
16	4	COTTER PIN, 1/8"DIA. x 1"LG.	6-0267
17	8	FLAT WASHER, 5/64"ID x 1"OD x 1/16"THK.	6-0808
18	1	SAFETY DOG WELDMENT, POWER SIDE	2-1901
19	4	SELF TAPPING SCREW, #10 X 3/8" LG.	6-0169
20	2	SAFETY SPRING	1-1115
21	6	SELF TAPPING SCREW, #12 x 1/2"LG.	6-1134
22	3	SHOULDER BOLT, 3/8"DIA. x 1"LG.	6-0206
23	2	SAFETY PULLEY	1-0415
24	3	SAFETY CABLE PULLEY	1-1116
25	1	SHOULDER BOLT, 3/8" X 1 1/2" LG.	6-0801
26	1	THIMBLE, 5/32"	6-2074
27	1	CAPACITY DECAL	6-1766
28	1	SERIAL PLATE	6-1111
29	1	TOWER WELDMENT, SLAVE SIDE - 12FT MODEL	4-0756
	1	TOWER WELDMENT, SLAVE SIDE - 14FT MODEL	4-0753
30	1	SAFETY DOG, SLAVE SIDE	2-0872
31	1	SHOULDER BOLT, 3/8"DIA. x 1 1/2"LG.	6-0801
32	1	ACTUATOR BAR	1-1439
33	1	FOAM GUARD	6-1404
34	1	CROSSMEMBER WELDMENT	2-1592
35	4	CROSSMEMBER PULLEY PIPE, 1/2"LG.	1-1623
36	16	FLAT WASHER, 3/4"ID	6-0738
37	2	CROSSMEMBER PULLEY PIPE, 1 3/4"LG.	1-1626
38	2	CROSSMEMBER PULLEY SHAFT	2-1251
39	4	COTTER PIN, 1/8"DIA. x 1 1/2"LG.	6-0978
40	1	SAFETY COVER cw/DECALS, POWER SIDE	0-0204
41	1	SAFETY COVER cw/DECALS, SLAVE SIDE	0-0203
42	8	SOCKET HEAD CAP SCREW, 3/8" X 1" LG.	6-2048
43	12	LOCKWASHER, 3/8" ID	6-0058
44	4	ARM LOCK ASSEMBLY	1-2038
45	4	HEX BOLT, 5/16"-18UNC x 3/4" LG.	6-0423
46	4	ARM PIN	2-1594
47	8	HEX BOLT, 5/16"-18UNC x 1 1/4" LG.	6-2059
48	4	ARM LOCK GEAR	1-2044
49	4	HEX BOLT, 3/8"-UNC x 3/4" LG.	6-0030
50	4	INNER ARM WELDMENT	3-0742

ITEM	QTY	DESCRIPTION	PART #
51	4	OUTER ARM WELDMENT	3-0850
52	4	LOCKING ARM ASSEMBLY cw/ARM LOCK PIN	4-0949-6
53	4	STACK PAD ASSEMBLY	1-2045
54	7	HEX BOLT, 1/4"-20UNC x 3/4" LG.	6-0178
55	4	RUBBER PAD	6-2050
56	4	STACK PAD WELDMENT	1-2030
57	4	STACK PAD ADAPTER, 3"	1-1993
58	4	STACK PAD ADAPTER, 6"	2-1580
59	2	STACK PAD ADAPTER HOLDER	1-2012
60	10	LOCKWASHER, 1/4" ID	6-0056
61	10	ROUND HEAD SCREW, 1/4"-20UNC x 3/8" LG.	6-1353
62	10	HEX NUT, 3/4"-10UNC	6-0737
63	10	FLAT WASHER, 3/4" ID	6-0738
64	10	WEDGE ANCHOR, 3/4"-10UNC x 5 1/2" LG.	6-1379
65	1	PLASTIC KNOB	6-1135
66	1	SAFETY RELEASE HANDLE	1-1113
67	8	HEX BOLT, 1/2"-13UNC x 1 1/4" LG.	6-0046
68	3	RUBBER GROMMET	6-1507
69	2	EQUALIZING CABLE – 12FT MODEL	1-2039
	2	EQUALIZING CABLE – 14FT MODEL	1-2003
70	1	SAFETY RELEASE CABLE	1-2058
71	7	HEX HD. NUT 1/4" NC	6-0032
72	2	6/32 SCREW (ELECTRICAL BOX)	6-1466
73	1	MICROSWITCH	6-0916
74	1	LIMIT SWITCH MTG. BRACKET	2-1143
75	1	ELECTRICAL UTILITY BOX	6-1403
76	1	CABLE CONNECTOR	6-1133
77	1	ELEC. CABLE 12/3 x 117" LG. – 12FT MODEL	6-1173
	1	ELEC. CABLE 12/3 x 141" LG. – 14FT MODEL	6-1513
78	1	ACTUATOR EXTENSION – 12 FT MODEL	1-2143
	1	ACTUATOR EXTENSION – 14 FT MODEL	1-1823
79	1	HEX HD. BOLT 1/4" NC x 2" LG.	6-0741
80	2	HEX HD. BOLT 1/4" NC x 1 1/4" LG.	6-0027
81	1	HEX HD. BOLT 1/4" NC x 1 1/2" LG.	6-0205
82	2	SHOULDER BOLT, 3/8" DIA. x 5/8" LG.	6-0069
83	2	HEX NUT, 5/16"-18UNC	6-0294
84	1	ACTUATOR MTG. BRACKET	1-1378
85	2	WIRE ROPE CLIP, 1/16"	6-2060
86	3	ELECTRICAL CABLE CLIP, 5/8" ID	6-1759
87	6	TUBE CLAMP, 1/2"	6-0536
88	8	FLATWASHER, 3/8"	6-0625

### 8.3 HYDRAULIC SYSTEM

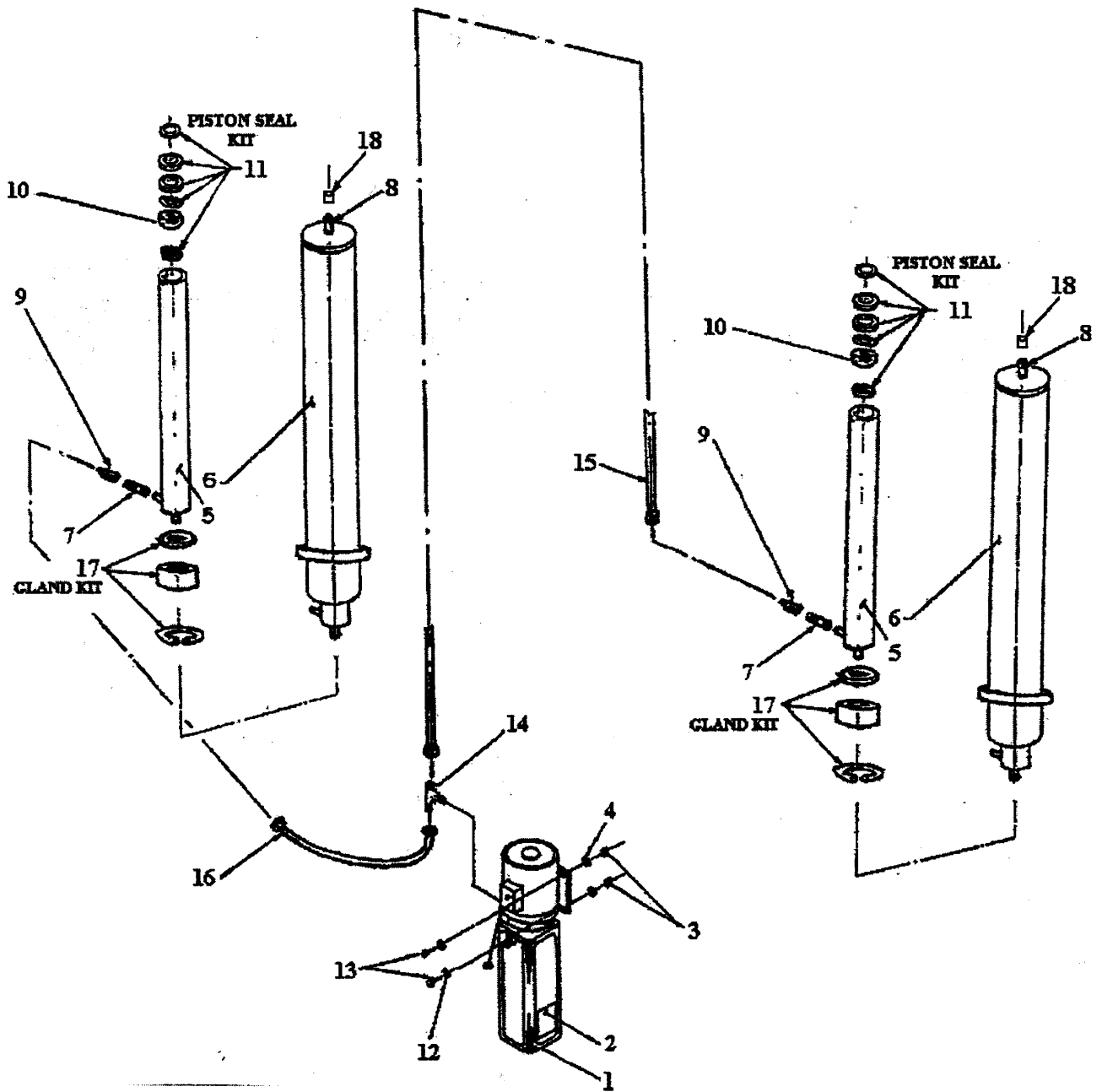

## 8.4 HYDRAULIC SYSTEM PARTS LIST

ITEM	QTY	DESCRIPTION	PART #
1	1	POWER PACK, 220V/1PH	6-2055
	1	POWER PACK, 220V/3PH	6-2665
2	1	"LIFT OPERATION" DECAL	6-1265
3	4	HEX NUT, 5/16"-18UNC	6-0294
4	4	LOCK WASHER, 5/16" I.D.	6-0674
5	2	PISTON ROD 1 1/4" O.D. x 1/4" W x 72 11/16 LG.	1-1469
6	2	CYLINDER TUBE MACHINED	1-1465
7	2	MALE NIPPLE, 1/4" NPT	6-2095
8	2	1/8" NPT TO 1/4" JIC ADAPTER	6-0280
9	2	FLOW CONTROL	6-1510
10	2	PISTON	1-1467
11	2	PISTON SEAL KIT	0-0337
12	4	FLAT WASHER, 5/16" I.D.	6-0295
13	4	HEX BOLT, 5/16"-18UNC x 1" LG.	6-0293
14	1	BRANCH TEE	6-1506
15	1	HYDRAULIC HOSE (LONG) - 12FT MODEL	1-2040
	1	HYDRAULIC HOSE (LONG) - 14FT MODEL	1-2004
16	1	HYDRAULIC HOSE (SHORT)	2-1230
17	2	GLAND KIT	0-0338
18	2	1/4" JIC CAP	6-1884
	*	CYLINDER ASSEMBLY (INCL. FLOW CONTROL)	3-0621
		<i>3 PH POWERPACK INCLUDES THE FOLLOWING (NOT SHOWN)</i>	
*	1	CONTACTOR BOX (REMOVE JUMPER & WIRE FOR 3PH)	6-1575
*	1	CONTACTOR BRACKET	2-1130
*	1	COVER PLATE	1-1369
*	2	HEX BOLT, 1/4"-NC x 1" LG	6-0008
*	4	LOCKWASHER, 1/4"	6-0056
*	2	HEX NUT, 1/4"-NC	6-0032
*	2	STRAIN RELIEF	6-0094
*	2FT	CABLE, 14/4	8-0287



### 8.5 POWER PACK:

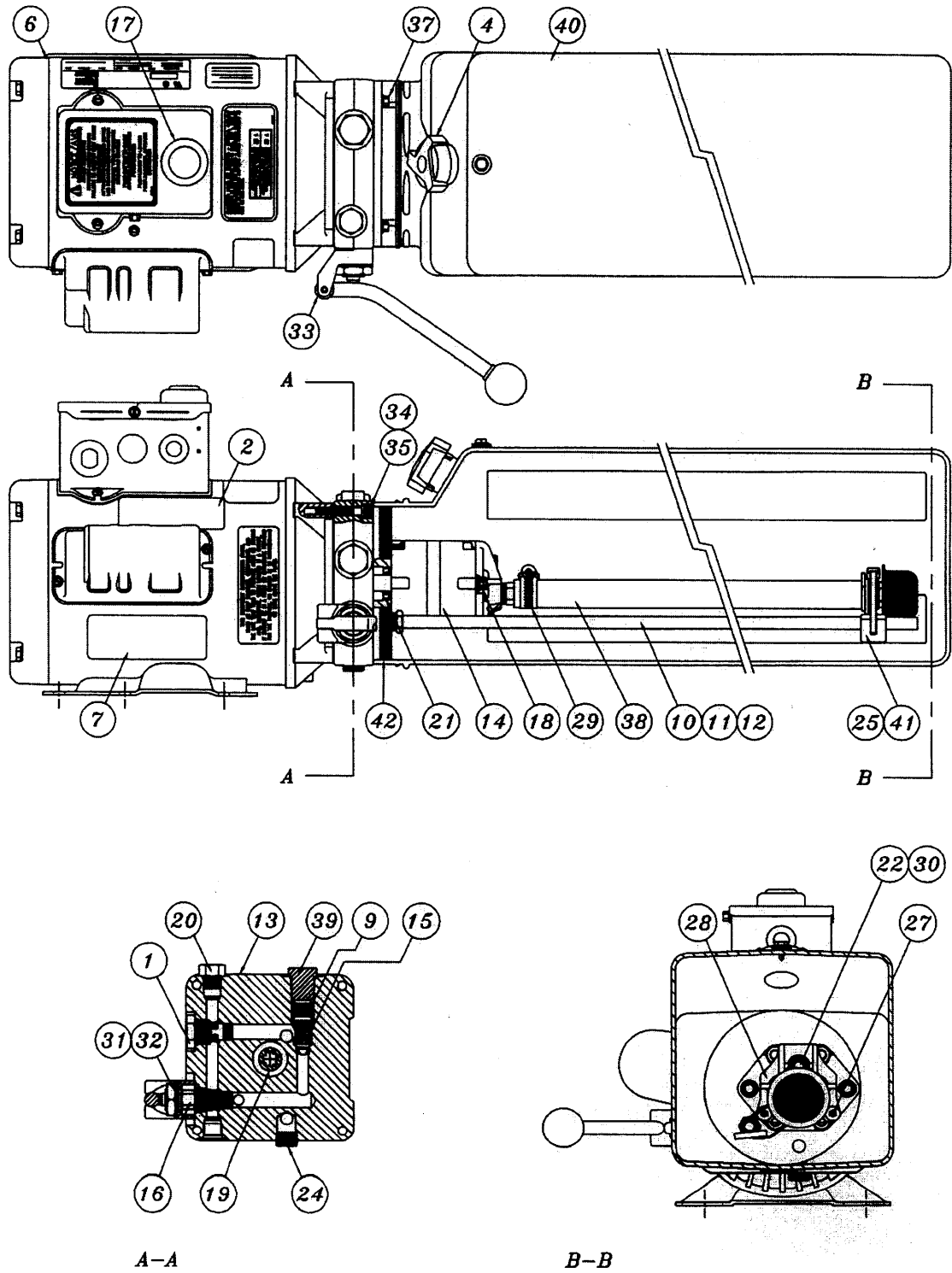

## 8.6 POWER PACK PARTS LIST:

#6-2055 (AB-1381) 208-230V/1PH/60Hz

#6-2665 (AD-1044) 208-230V/1PH/60Hz

ITEM	QTY.	DESCRIPTION	PART #
1	1	VALVE CARTRIDGE CHECK	6-1087
2	1	LABEL INSTALLATION AUTOHOIST	6-2136
4	1	BREATHER CAP & BLADDER	6-1376
6	1	MOTOR AC 208-230V. 2HP/1PH/60Hz, BLK	6-2139
	1	MOTOR AC 208-230V. 2HP/3PH/60Hz, BLK	6-1079
7	1	LABEL WARNING AUTOHOIST	6-2149
9	1	SPRING 0.480" x 0.063" x 0.42" COMP	6-2151
10	1	RETURN HOSE 3/8" OD x 21.5"	6-2152
11	1	COMPRESSION TUBE NUT	6-2153
12	1	COMPRESSION TUBE SLEEVE	6-2154
13	1	ENDHEAD UNIVERSAL AUTOHOIST	6-2155
14	1	PUMPASSY 2.5 CC/REV. SHORT SPLINE	6-1958
15	1	RELIEF ASSEMBLY FIXED 190 BAR	6-1319
16	1	VALVE CARTRIDGE RELEASE MANUAL	6-0880
17	1	WIRING ASSEMBLY AC 1PH FENNER	6-2156
18	2	BOLT 5/16"-24 x 3.00" TORX G8	6-1090
19	1	COUPLING SAE 9T-20/40 1.260"	6-0774
20	1	PLUMBING PLUG 9/16" SAE	6-2157
21	1	SEAL SHAFT 0.500" x 1.00" x 0.25"	6-2158
22	1	WASHER 0.338" x 0.625" x 0.060" STEEL	6-2159
24	1	PLUMBING PLUG 3/8" NPT	6-2161
25	1	PLUMBING MAGNET	6-2162
27	2	SCREW TAPTITE M6 x 1.0 12MM TORX	6-2164
28	1	COVER ASSY SUCTION	6-2165
29	1	PLUMBING CLAMP HOSE ADJ. INLET	6-2166
30	1	BOLT 5/16"-18 x 1.00" SHCS	6-1392
31	1	NUT 3/4"-16 x 1" HEX x 0.250" STEEL	6-2167
32	1	WASHER 3/4" INT. TOOTH LOCK	6-2168
33	1	BRACKET - HANDLE ASSY REL BLACK	6-0776
34	4	BOLT M6 x 1.0 35MM SOC HD	6-2169
35	4	WASHER 1/4" LOCK HI-COLLAR	6-2170
37	4	BOLT #12-24 x 0.50' HEX WSHRHD	6-1091
38	1	PLUMBING ASSY INLET 17.24 (3)	6-0786
39	1	RELIEF VALVE CAP ASSEMBLY	6-1089
40	1	TANK PLASTIC 6.7 OS 22.50" BLK	6-1399
41	1	CABLE TIE 8" LONG WHITE	6-1846
42	1	O-RING 2-348 BUNA	6-0875

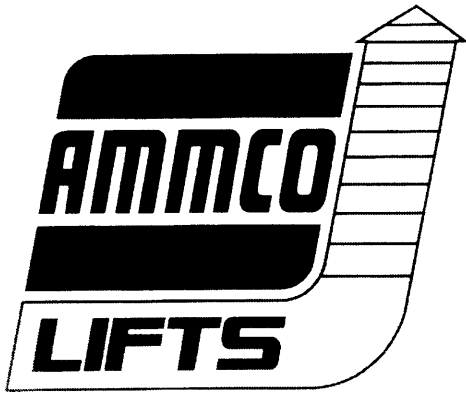

# INSTALLATION and OPERATION MANUAL

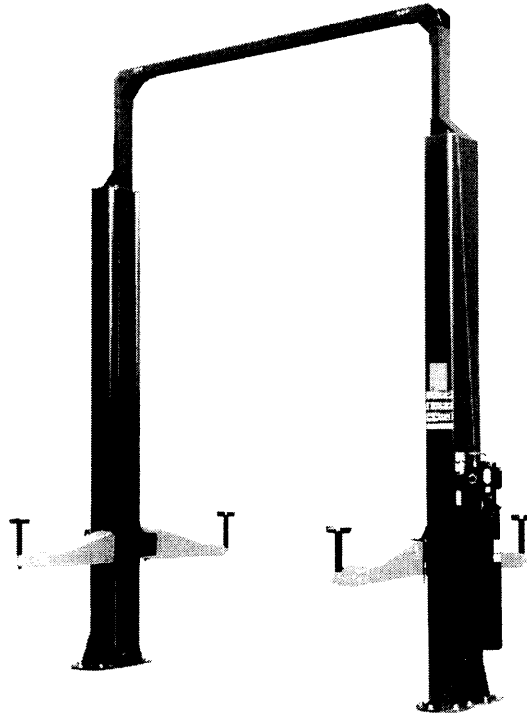

**12K 2 POST  
S212AR □ - 1/3**

**READ and SAVE THIS  
INSTRUCTION MANUAL**

JAN 2002 6-2704

**READ THIS MANUAL BEFORE INSTALLATION AND/OR OPERATION !**

12001 2-POST

This is a vehicle lift operation manual and no attempt is made or implied herein to instruct the user in lifting methods particular to an individual application. Rather, the contents of this manual are intended as a basis for operation and maintenance of the unit as it stands alone or as it is intended and anticipated to be used in conjunction with other equipment.

Proper application of the equipment described herein is limited to the parameters detailed in the specifications and the uses set forth in the descriptive passages. Any other proposed application of this equipment should be documented and submitted in writing to AUTOMOTIVE LIFTS & MACHINERY CORP.'S examination. The user assumes full responsibility for any equipment damage, personal injury or alteration of the equipment described in this manual or any subsequent damages.

**WARNING:**

Installation of equipment is hazardous. Only qualified personnel should perform installation procedures. Installers should familiarize themselves with equipment and installation procedure before attempting installation.

Decommission and disposal of product must be performed in accordance with local, state and/or federal regulations.

**The Owner/Employer shall** ensure that lift operators are qualified and that they are trained in the safe use and operation of the lift using the manufacturer's operating instructions; ALI/SM 93-1, ALI SAFETY Tips card; ANSI/ALI ALOIM-1994, American National Standard for Automotive Lifts-Safety Requirements for Operation, Inspection and Maintenance; ALI/WL Series, ALI Uniform Warning Label Decals/Placards; and in the case of frame engaging lifts, ALI/LP-GUIDE, Vehicle Lifting Points/Quick Reference Guide for Frame Engaging Lifts.

**The Owner/Employer shall** establish procedures to periodically inspect the lift in accordance with the lift manufacturer's instructions or ANSI/ALI ALOIM-1994, American National Standard for Automotive Lifts-Safety Requirements for Operation, Inspection and Maintenance; and the employer shall ensure that lift inspectors are qualified and that they are adequately trained in the inspection of the lift.

**The Owner/Employer shall** establish procedures to periodically maintain the lift in accordance with the lift manufacturer's instructions or ANSI/ALI ALOIM-1994, American National Standard for Automotive Lifts-Safety Requirements for Operation, Inspection and Maintenance; and the employer shall ensure that lift maintenance personnel are qualified and that they are adequately trained in the maintenance of the lift.

**The Owner/Employer shall** maintain the periodic inspection and maintenance records recommended by the manufacturer or ANSI/ALI ALOIM-1994, American National Standard for Automotive Lifts-Safety Requirements for Operation, Inspection and Maintenance.

**The Owner/Employer shall** display the lift manufacturer's operating instructions; ALI/SM 93-1, ALI Lifting it Right safety manual; ALI/ST-90 ALI Safety Tips card; ANSI/ALI ALOIM-1994, American National Standard for Automotive Lifts-Safety Requirements for Operation, Inspection and Maintenance; and in the case of frame engaging lifts, ALI/LP-GUIDE, Vehicle Lifting Points/Quick Reference Guide for Frame Engaging Lifts in a conspicuous location in the lift area convenient to the operator.

**The Owner/Employer shall** provide necessary lockout/tagout means for energy sources per ANSI Z244.1-1982 (R1993), Safety Requirements for the Lockout/Tagout of Energy Sources, before beginning any lift repairs.

**The Owner/Employer shall** not modify the lift in any manner without prior written consent of the manufacturer.

## AUTOMOTIVE LIFT

### SAFETY INSTRUCTIONS

Please read and post these tips in a place where the operator will be constantly reminded of their importance. REFER TO THE OPERATING AND INSPECTION AND MAINTENANCE INSTRUCTION.

1. When positioning vehicle, do not hit or run over lift arms, adapters or axle supports.
2. Remove passengers prior to raising vehicle.
3. Operating valves, switches and locking devices are designed for maximum safety. Never attempt to block open or override them.
4. Never overload your lift beyond stated capacity.
5. Do not allow customers or by-standers to operate lift or to be in lift area during its operation. Never raise vehicle with anyone inside it.
6. Be sure work area around lift is clear - free of obstruction, debris, grease and oil.
7. Never attempt to operate a lift if it appears to be malfunctioning or if broken or damaged parts are evident.
8. Load lift carefully. Check to be sure the lifting pads are in secure contact with vehicle before raising to desired working height.
9. After lifting the vehicle to desired height, ALWAYS lower the unit onto the mechanical safeties. The forming of good operational work habits will eliminate oversights in the use of provided safety devices.
10. Release locking devices before attempting to lower lift.
11. Before removing vehicle from lift area, position arms, adapters or axle supports to assure that vehicle or lift will not be damaged.
12. Care must be taken as burns can occur from touching hot parts.
13. Do not operate equipment with a damaged cord or if the equipment has been dropped or damaged - until it has been examined by a qualified serviceman.
14. Do not let the cord hang over edge of table, bench or counter or come in contact with hot manifolds or moving fan blades.

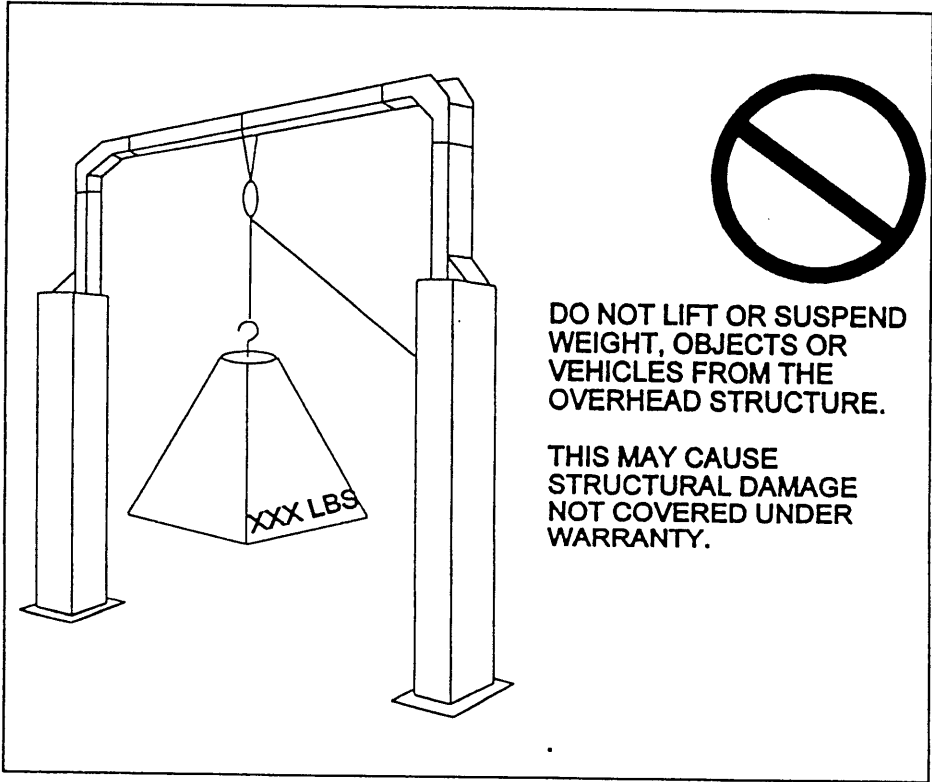
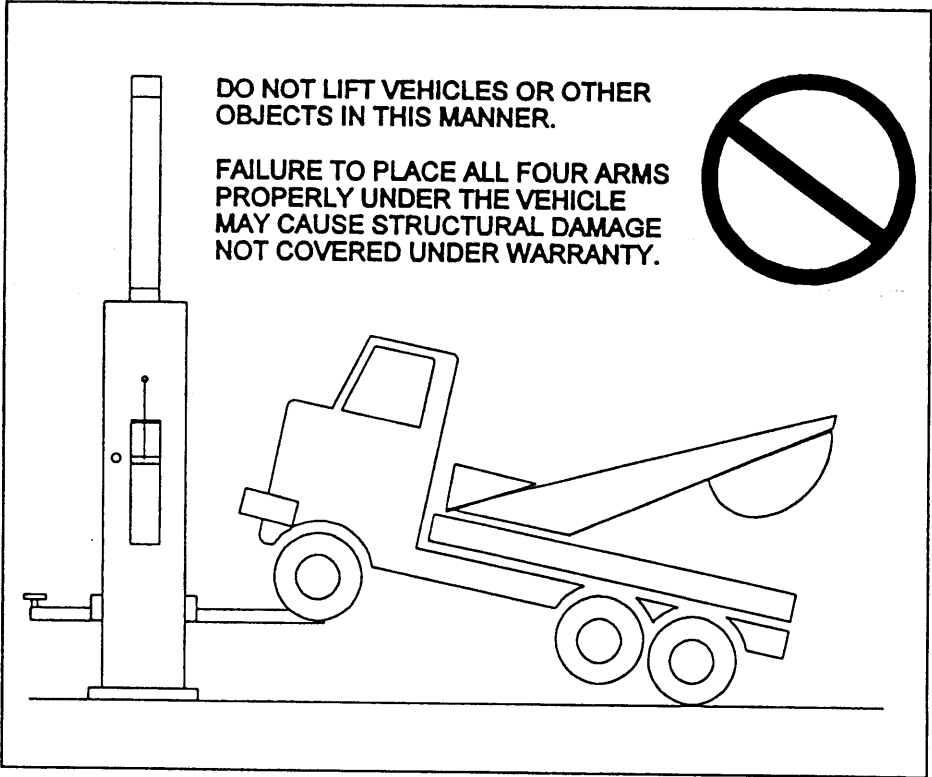

## ALM CLEAR FLOOR 2 POST LIFT OPERATION INSTRUCTIONS

### To Raise Vehicle:

1. Lower carriages to the floor position.
2. Retract lifting arms to minimum length.
3. Swing arms away from the path of the vehicle. Before spotting the vehicle, consult "Quick Reference Guide, Vehicle Lifting Points for Frame Engaging Lifts" (ALI/LP-Guide).
4. During loading or spotting, center the vehicle between the columns as shown in figure. Also see "Spotting the Vehicle and The Center of Gravity" in the "LIFT IT RIGHT" safety manual.
5. Swing the arms under the vehicle. Position the vehicle support pads at the **VEHICLE MANUFACTURERS RECOMMENDED LIFTING POINTS**.  
Beginning with some 1994 year models, auto makers will identify recommended lift points by placing a label on the vertical lock face plate of the front passenger side door. (ANSI/SAE J2184-OCT92)
6. Clear area around the lift.
7. Raise the vehicle until the vehicle support pads are in full contact, approximately 12" off floor. Check to see that vehicle is stable on the lift by moderately rocking the bumper. Recheck the position of the pads for any movement.
8. Raise the vehicle to the desired working elevation and release control button.
9. Lower to the safety latches, vehicle is now ready for service.

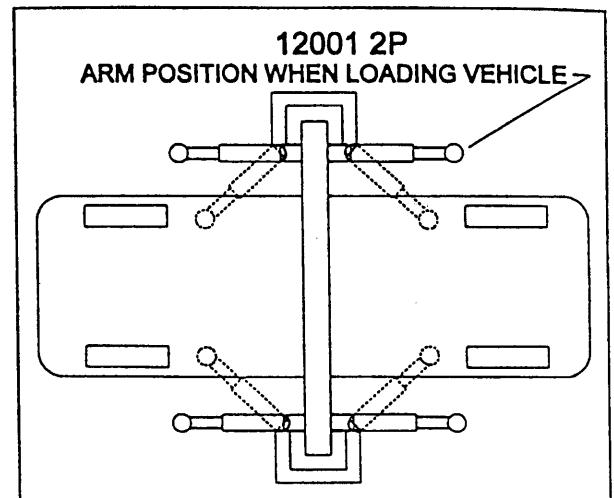

**STATEMENT OF DESIGN LIMITATION.** The ALM 12001 is a two-post, frame engaging, surfaced mounted, 12000 Lbs. capacity lift. The intended use is to lift motor vehicles within the stated capacity. The ALM 12001 2P is NOT INTENDED for use with transit, industrial, agricultural or recreational applications.



SPECIAL INSTRUCTIONS for long wheelbase vehicles such as limousines, cargo vans, light trucks with toolboxes, extended and dual cab light trucks, etc.

1. Do not lift without finding the vehicles center of gravity.
2. Do not exceed the stated capacity of the lift.
3. Do not operate the lift if the load is not stable.
4. Observe overhead clearance for obstructions when lifting light trucks with ladder racks, cranes, campers, etc.
5. Always use all four arms when lifting a vehicle and follow the vehicle manufacturers guide lines for recommended lifting points.
6. Height extenders may be needed for proper frame engagement when lifting light trucks and vans.
7. Do not use wood, bricks, homemade extenders, etc. Use extenders manufactured by ALM, for specific use with ALM model 12001 2P.

CAUTION: SHOULD ANY MAJOR WEIGHT COMPONENT BE REMOVED OR ADDED AFTER THE VEHICLE IS RAISED, USE A JACK STAND TO SUPPORT THE OVER BALANCED END DURING THE MAINTENANCE PROCEDURE AS SHOWN IN THE FIGURE.

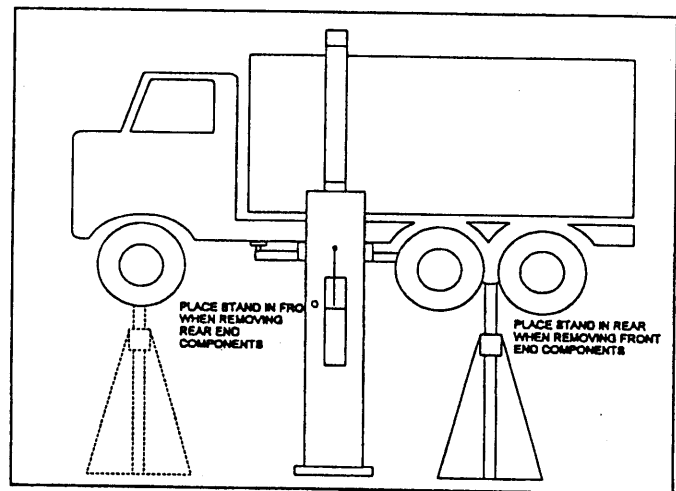

To Lower Vehicles:

1. Clear area around and under the lift of obstructions and warn personnel to stand clear.
2. Raise vehicle slightly to remove pressure on the safety latches.
3. Depress air valve and pull release lever on pump.
4. No one must be under the vehicle when lowering as the safeties are released.
5. Lower the lift until arms have bottomed and are clear of the lifting points.
6. Swing the lifting arms from beneath the vehicle and fully retract the arms.
7. Remove the vehicle.

## IMPORTANT WARNINGS:

1. Do not operate the lift unless safety latches are functioning as evidenced by the safety latches dropping into the safety ladder slots during the raising motion.
2. Do not operate the lift if the load tilts or binds during the up or down movement.
3. Always use all four arms when lifting a vehicle and follow the vehicle manufacturers guide lines for recommended lifting points.

## INSPECTION AND MAINTENANCE PROCEDURES

The schedule is based on conditions found in the usual automotive service environment under normal usage (approximately 1200 cycles per year). In cases of high volume operation or areas with a high density of airborne debris, the schedule must be accelerated.

1. SAFETY LATCH WORKING / CHECK DAILY / ADJUST CABLE TENSION IF OUT OF SYNCHRONIZATION.
2. ARM PINS / CHECK SEMI-ANNUAL / LUBE EVERY 6 MONTHS WITH GREASE.
3. RUBBER LIFT PADS / REPLACE IF SEVERELY DAMAGED
4. ARM RESTRAINT RODS / CHECK MONTHLY / KEEP THREADS CLEAN AND RUST FREE.
5. SPINDLE PADS / CHECK MONTHLY / KEEP THREADS CLEAN AND RUST FREE. USE LIGHT OIL.
6. COLUMN ANCHOR BOLTS / CHECK QUARTERLY / CHECK WEEKLY IN THE FIRST MONTH OF OPERATION, MIN 150 FT. LBS. OF TORQUE. IF UNABLE TO TIGHTEN SUSPEND USE OF LIFT AND CONTACT FACTORY.
7. FLOOR CRACKS EMULATING FROM UNDER COLUMNS / CONTACT FACTORY
8. STRUCTURAL WEAR, CRACKS OR VISUALLY OUT OF PLUMB / CONTACT FACTORY
9. EQUALIZATION CABLE / CHECK SEMI-ANNUAL / SEE PAGE FOR INSPECTION PROCEDURE.
10. CARRIAGE BEARINGS / CHECK SEMI-ANNUAL / GREASE WITH LITHIUM RP #2. REPLACE BEARINGS WHEN CLEARANCE BETWEEN BEARING MOUNTING PLATES AND COLUMN IS LESS THAN 1/16".
11. HYDRAULIC FLUID / REPLACE EVERY TWO YEARS WITH CITGO AW 46 OR EQUAL.

## EQUALIZATION CABLE INSPECTION

Without load raise the lift in increments that will allow inspection of the entire cable.  
If the following conditions exist replace the cable:

1. When its diameter is less than  $1\frac{1}{32}$ ".
2. If 3 or more element wires are broken in 1 strand.
3. If 6 or more element wires are broken in a strand lay.
4. Badly deformed or rusted.
5. Broken wires at the connection to threaded rods.

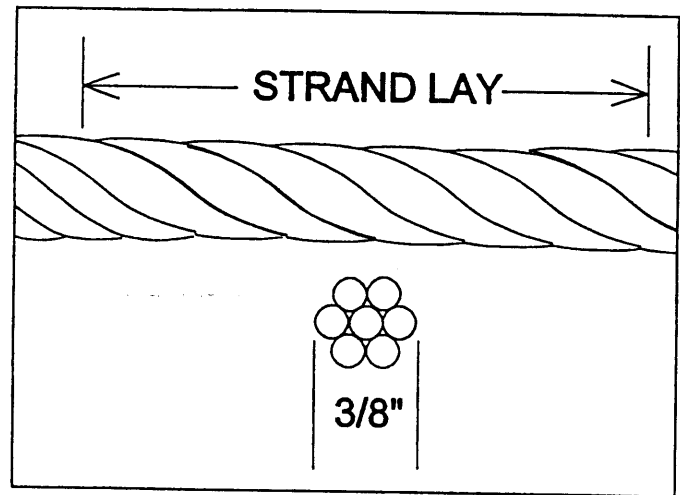

Inspect the lower column and vertical profile pulleys for broken flanges, excessive wear in the groove, bushing or axle.

Annually lubricate the entire cable with light oil.

## IMPORTANT NOTICE!!

The floor on which the lift is to be installed must be a minimum thickness of 4" reinforced concrete with a minimum compressive strength of 4000 PSI.

Failure by the purchaser to provide the recommended mounting surface could result in unsatisfactory lift performance, property damage or personal injury.

### GENERAL TOOLS FOR INSTALLATION:

Rotary hammer drill with 3/4" solid drill bit with carbide tip Level

Hand Sledge

Pry Bar

Tape Measure

Chalk line

12' Ladder

Shortened 1/16" open-end Wrench

Vise Grips

Snap Ring Pliers

11/16" Open End Wrench

5/8" Open End Wrench

9/16" Socket and suitable ratchet

7/16" Socket and suitable ratchet

1/2" Socket and suitable ratchet

1 1/8" Deep Socket and suitable ratchet

4 Gal. Hydraulic fluid - Citgo A/W 46 or suitable cross-reference

## ALM 12001 CLEAR FLOOR 2 POST LIFT INSTALLATION MANUAL

### COLUMN PLACEMENT

1. Placement of lift should be at least 12' from nearest obstacle, front to rear, plus any desired aisle or work area between vehicle and obstacle such as garage door, work bench, etc. Place a chalk line at the selected location, erect both columns in their respective locations outside baseplate to baseplate and square to chalk line. The control column may be placed on either side. (See Fig. 1).
2. AT THIS TIME install the air valve with the pre-assembled air fittings into the small hole at the lower left of the 4 motor mounting studs on the control column. The palm button and locknuts must be removed for the valve stem to pass thru the hole. Reassemble once thru the hole (See Fig. 2). Connect the 2 pre-assembled air hoses inside the control column to the air valve by pushing the 1/4" air hose into the top fitting and pushing the 5/32" air hose to the bottom fitting. Connect the 5/32 X 94 3/4" air hose (in hardware kit) to the 90 degree fitting on the air valve.  
  
Unfold the metal tabs holding the existing steel hydraulic tube in the control column. Install the double 90 degree steel hydraulic tube through the large hole from the inside of the column and fold the metal tabs back over both tubes. (See Fig. 7)
3. Beginning with the control column, manually raise the carriage to the 4th safety catch and stop. Drill holes and install concrete anchor bolts, but DO NOT TIGHTEN until column has been leveled, shim if necessary. If shims exceed 1/2", contact factory. Tighten anchor bolts a min. of 150 Ft. Lbs. DO NOT INSTALL anchor bolts for opposite control column at this time.
4. VERTICAL PROFILE ADJUSTMENT (IF REQUIRED)

A ceiling height of 189" inches or more is required to install 12001 lift as it comes stock from the factory (See Fig.3).

To install vertical profiles in less than 189" inches, measure from floor to ceiling (or any obstacle such as light fixture, heater, etc.) and subtract a minimum of 2" for horizontal profile clearance. Next, subtract this measurement from 187" inches. This determines the distance the vertical profiles are to be lowered. See example on next page.

Example: Floor to ceiling height 184"  
 minus  $\frac{-2''}{182''}$

Factory profile height 187"  
 minus -  $\frac{182''}{5''}$   
 Shorten vertical profile

NOTE : 20 Inches is the maximum the vertical profile can be lowered with stock cables on a 12001 2P. If more than this dimension is required, contact the factory for assistance.

1. After establishing the dimension by which the vertical profile is to be lowered, remove the eight 3/8 x 1-1/4" bolts from each vertical profile corner assembly.
2. By means of a bandsaw, or reciprocating saw, cut off the desired length from vertical profile.
3. Using vertical profile corner assembly as a template, redrill and reassemble vertical profile.

4. SHORTENING EQUALIZING CABLES

If the vertical profiles have been shortened, before installing equalizing cables, the long threaded rod on both cables must be shortened. To determine amount of threaded rod to cut off, double the amount the vertical profile was lowered.

Example : If you lower the vertical profile on a 12001 2P by 5" inches, you must shorten the long threaded rod by 10" inches.

5. SHORTENING HYDRAULIC TUBES (Vertical Profile)

Each vertical profile hydraulic tube that is shortened must be cut with tubing cutter. DO NOT use a hacksaw. Each tube that is cut must be flushed with cleaning fluid to prevent debris from entering the hydraulic cylinders and pump. A new ferrule must be installed on the tube.

Example: If the vertical profile is shortened 5", the tube is shortened 5".

When installing a new ferrule, use Parker Hannifin #6TU.

6. VERTICAL AND HORIZONTAL PROFILE INSTALLATION

First remove 2 of the 6 bolts (1 from each side of the small slot) located on the control column top plate. Place the vertical profile on the top plate and replace the 2 bolts. Install the 3/8"x 1-1/2" bolts with flat washers, lock washers and nuts in the remaining 4 holes. DO NOT TIGHTEN BOLTS AT THIS TIME.

Install remaining vertical profile on opposite column. DO NOT tighten profile bolts at this time.

Install horizontal profile using 3/8 x 1-1/4" nuts and bolts, flat washers and lockwashers. DO NOT TIGHTEN AT THIS TIME.

7. Confirm correct column placement dimension (See Fig. 1).

8. Manually raise the opposite control column carriage as described in step 3. NOTE : Both carriages must be at the same height. Drill holes and install concrete anchor bolts. Level shim if necessary. Tighten anchor bolts.

9. Tighten all overhead vertical and horizontal profile bolts.

10. CABLE INSTALLATION

Confirm that both carriages are of equal height. Stand facing the carriage of the control column. Beginning with the short threaded cable rod, run the cable up and over the vertical profile pulley, through the horizontal profile to the opposite column, down through the carriage, around the bottom column pulley and up through hole in the bottom of the carriage. The bottom column pulley must be removed and replaced. Continue to run the cable up and out the top of the carriage. Thread the 3/4 x 10 Nylock nut all the way on the short threaded rod (See Fig. 4 thru 6). Pull the cable with the short rod back down to its normal position. Insert the long threaded rod through hole on top of carriage and thread 3/4 x 10 Nylock nut on by hand as far as possible. DO NOT tighten at this time. Repeat the above for 2nd cable. To complete tightening of the cables, place a vise grip at least 6" above the 3/4 x 10 Nylock nut on the long threaded rod and a 1 1/16" wrench on the 3/4 x 10 Nylock nut. Turn the rod with the vise grip to thread Nylock nut on rod. Tighten each cable until approximately 1/2" deflection is present midpoint in the cable. If both safety latches fall in at the same time once the lift is operated up, no further cable adjustment is needed.

## 11. HYDRAULIC TUBES & AIR LINE

Mount power unit to studs on the control column. Install the male 90 degree hydraulic fitting (elbow) into the power unit with the opening pointed down. Connect the flexible hydraulic hose to the fitting on the power unit. Connect the flexible hose to the double 90 degree steel hydraulic tube. (See Fig. 7 & 8). Install one of two vertical profile hydraulic tubes. NOTE, the air line follows the same route as the hydraulic tubing. Starting with the control side, feed the coil of 5/32" air hose through the small slot in the column top. Tape the air hose to the second vertical profile hydraulic tube and use it as a guide to route the air line through the vertical profile.

Untape the air line and pull remaining line through the vertical profile. Assemble the three horizontal profile hydraulic tubes to the tee. Tighten all fittings. Using the horizontal profile hydraulic tube as a guide, tape the air line to the opposite the control side end of the hydraulic tube and install.

Untape the air line and pull the remaining line through the horizontal profile. Feed the air line down through the vertical profile, through the small hole in the column top plate and connect it to the pre-assembled 5/32 straight coupler at the top of the column. Install the remaining vertical profile hydraulic tube and tighten all remaining hydraulic fittings. Use wire ties to secure the air line to the hydraulic tube. Connect either a temporary or permanent air supply to the 1/4" NPT air intake on the control column top plate.

Remove the 4 bolts holding the oil reservoir and lower it to the floor. Check to see if the screen is on the pick-up tube and the magnet is in the bottom of the reservoir. Fill to the set screw. (Reservoir holds approximately 4 gallons) Re-install reservoir.

## 12. LIFT ARMS

Each lift arm has an eyebolt bracket for the threaded eyebolt. This bracket should correspond with the arm restraint device located on the side of the carriage. Grease and install arm axles. Attach snap ring on bottom of axle. Insert the threaded eyebolt into arm-restraint device by pushing up on the arm-restraint contact pin line up eyebolt hole with bracket on arm and insert the 3/4 x 3" bolt from the top, secure with 3/4" nylock nut (See Fig. 9).

13. Establish electrical power 220 Volt, Single Phase. Use 10 ga. wire with 2 pole 30 amp breaker (See Fig. 10).



14. SAFETY CABLE

Attach one end of the safety cable to the eye on the opposite control side vertical profile using the 1/16" cable crimps supplied. Run cable through the guide on control side vertical profile and guide on top of control side column to the safety limit switch activator on power unit and fasten. Trim any excess cable.

16. Operate the lift up until both hydraulic cylinders contact the carriages. Each cylinder has a bleed screw located on the top of the cylinder barrel. Open the bleed screws one full turn. This allows the air to be pushed out as the cylinder fills with oil. **DO NOT COMPLETELY REMOVE THE BLEED SCREWS.** When a solid stream of oil is present close the bleed screws. Operate the lift to full height.

To lower, depress the air valve palm button on the column and the hydraulic release lever on the pump. Raise and lower lift several times, then check the following:

- a) Both safety latches fall in at the same time.
- b) Both safety latches release properly.
- c) Hydraulic leaks.
- d) Arm - restraint function properly.
- e) Anchor bolt and all other nuts and bolts are tight.
- f) Safety Limit functions properly.

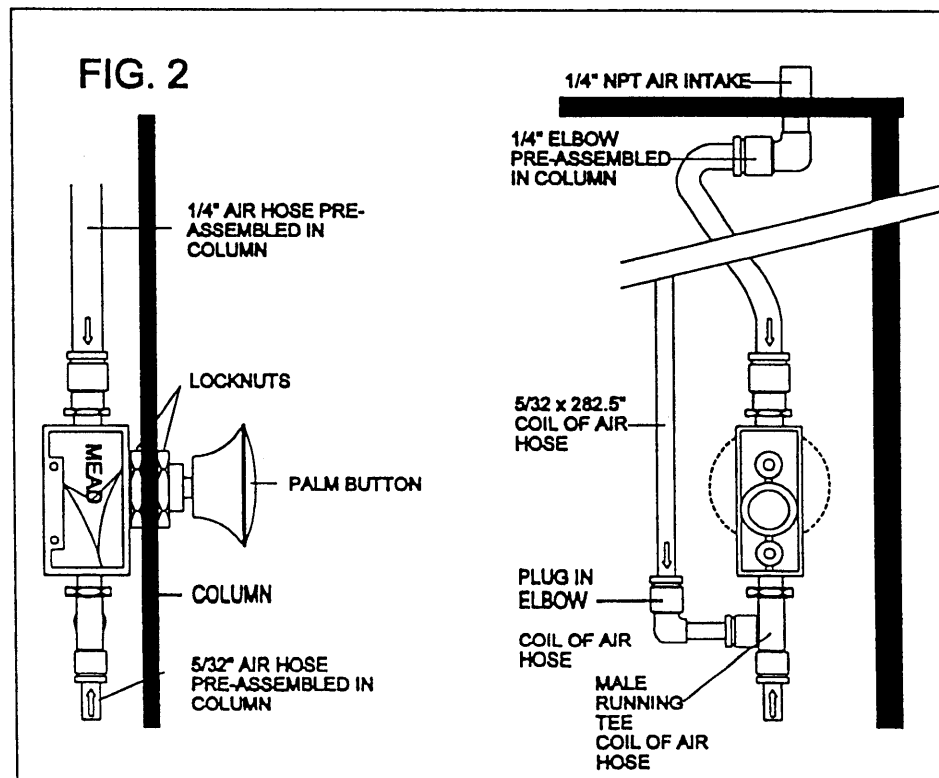
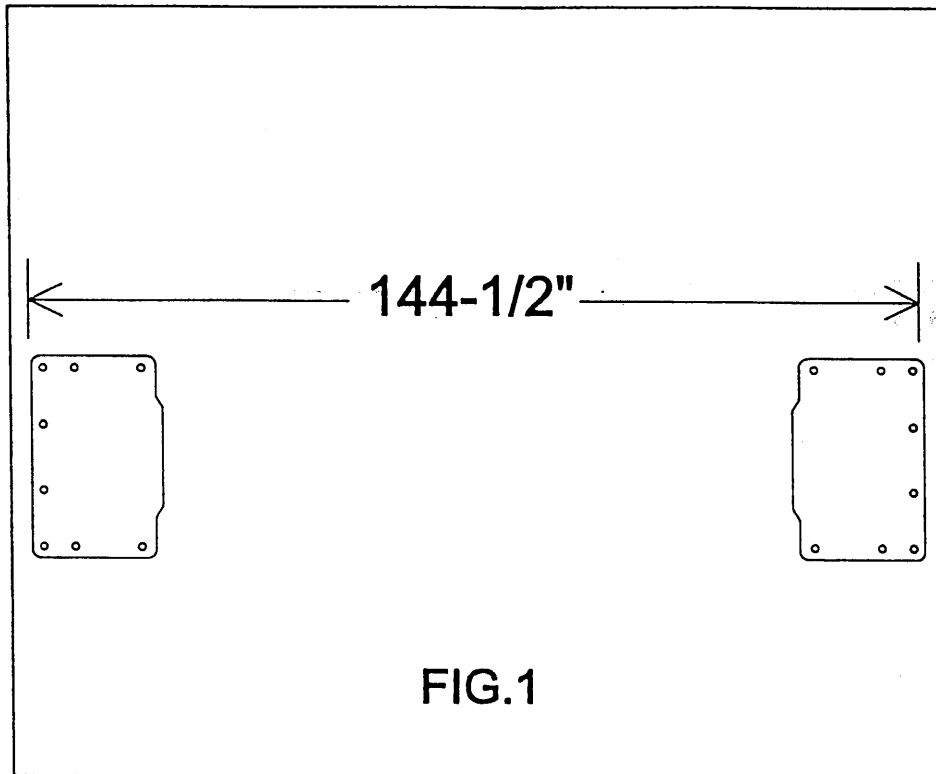

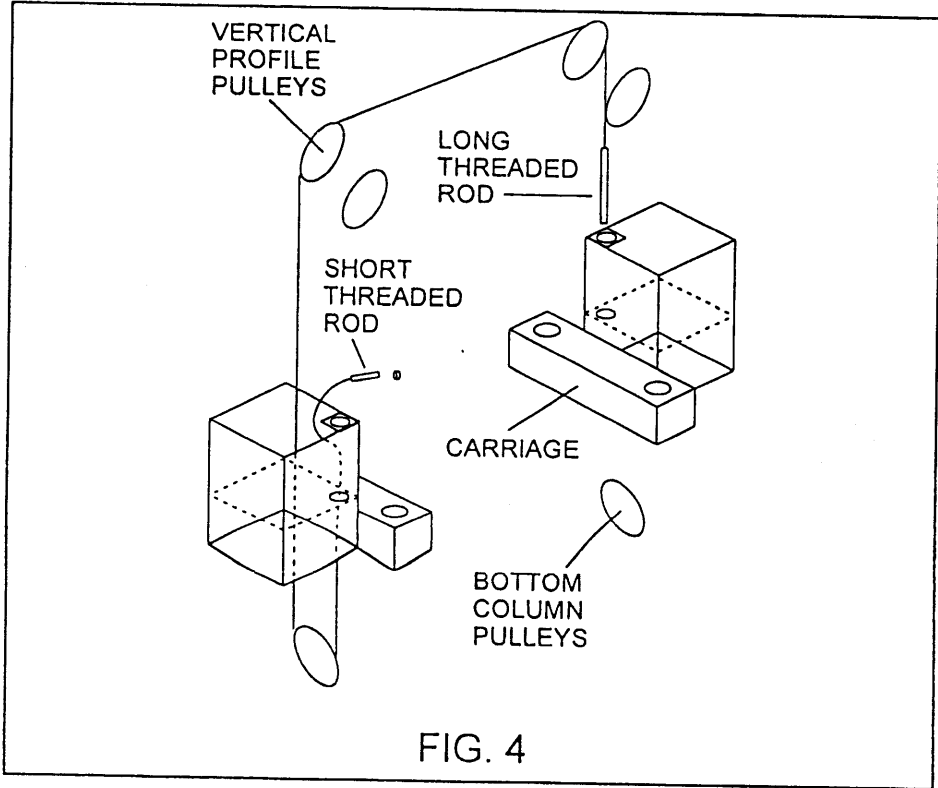
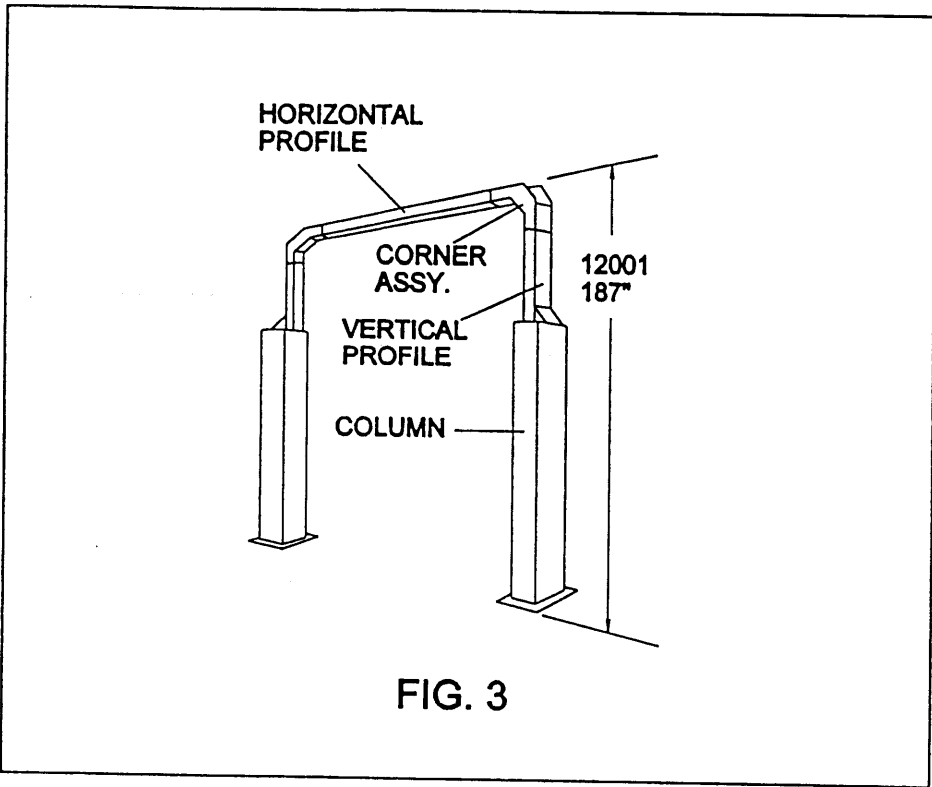

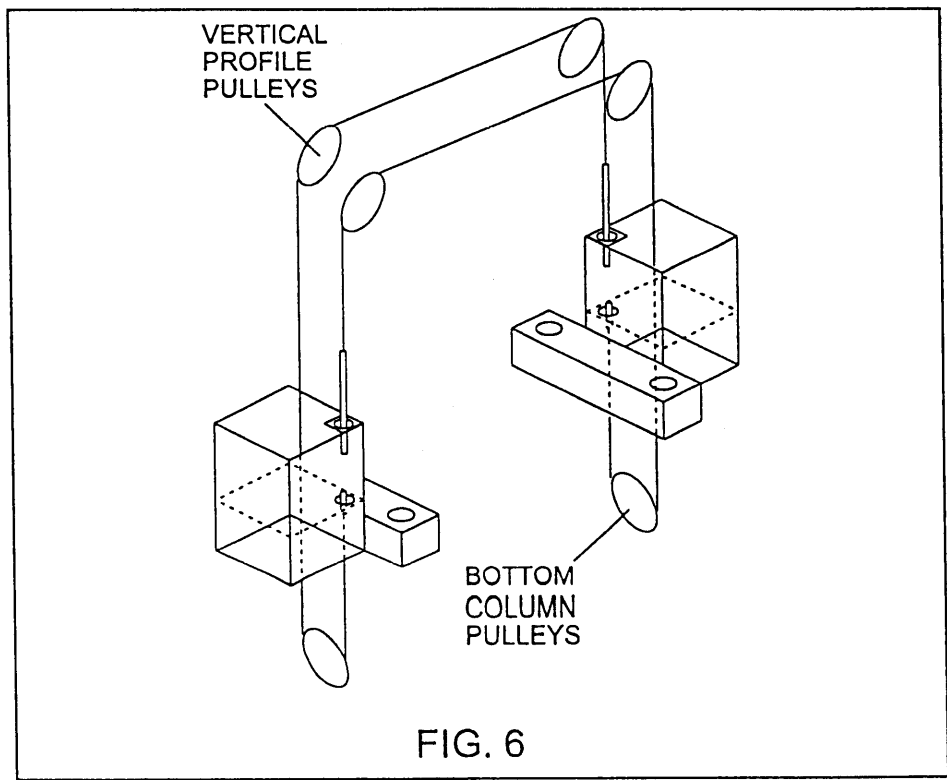
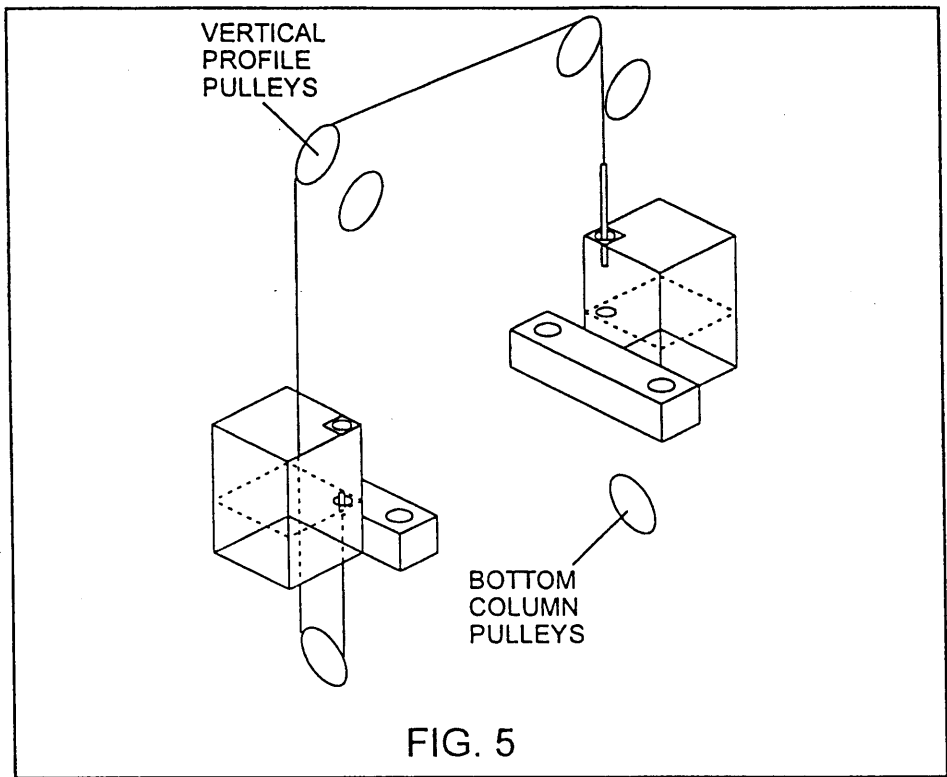

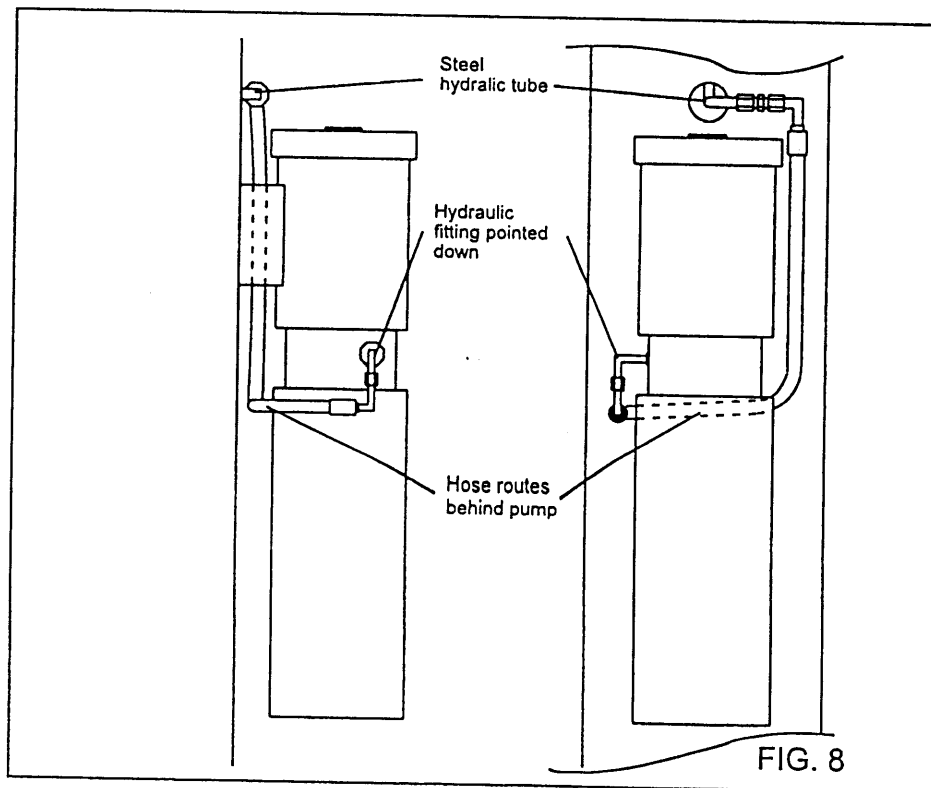
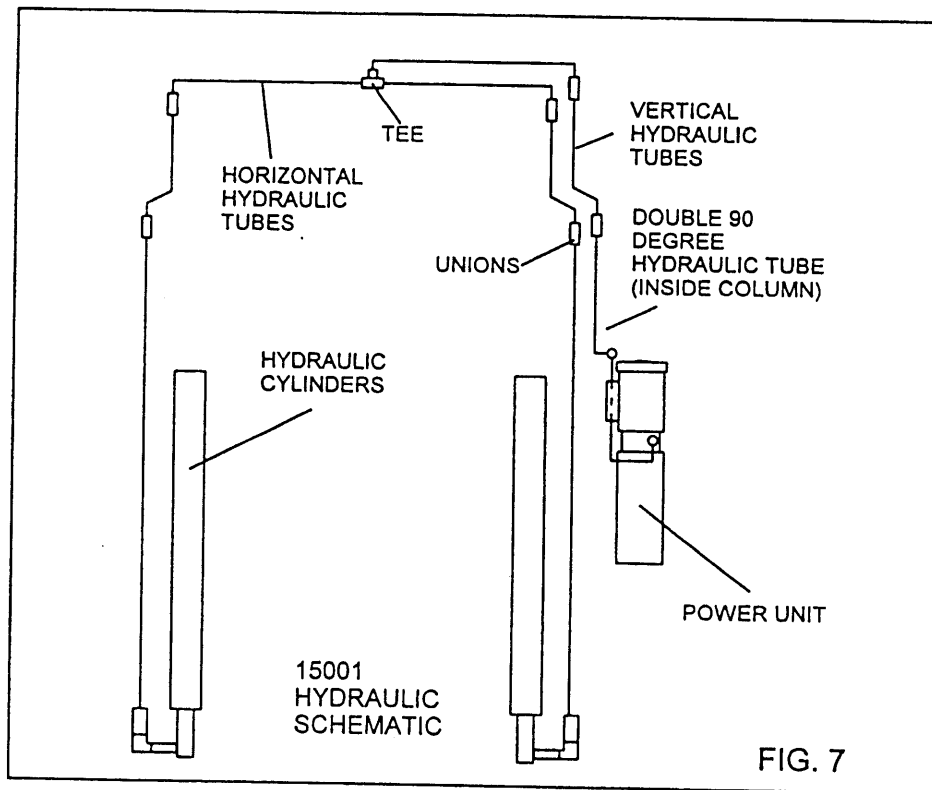

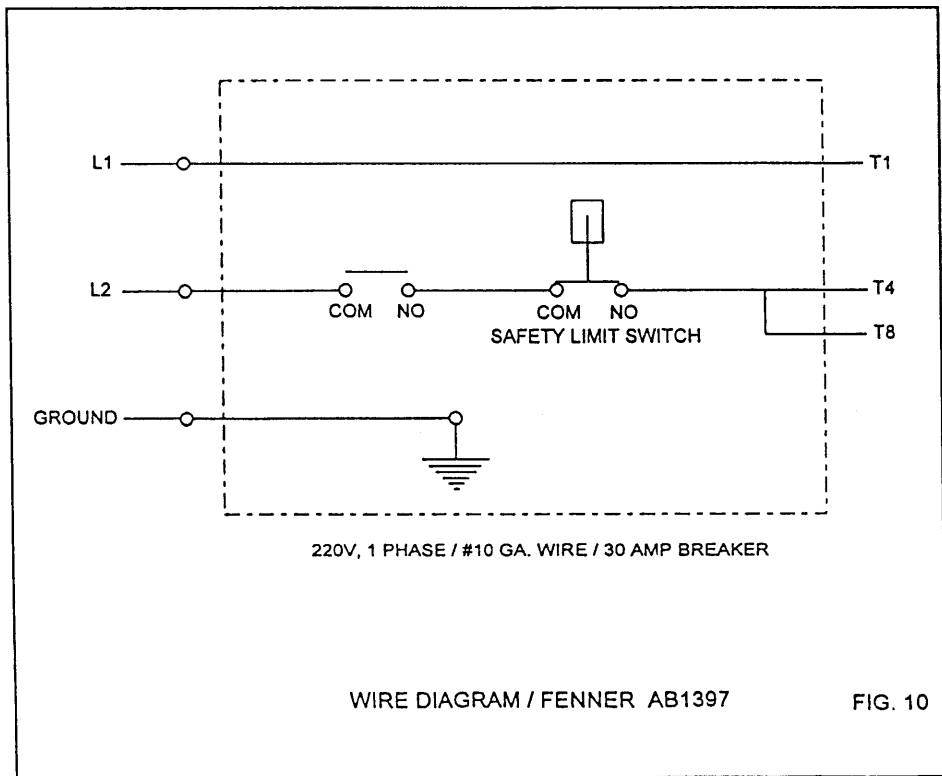
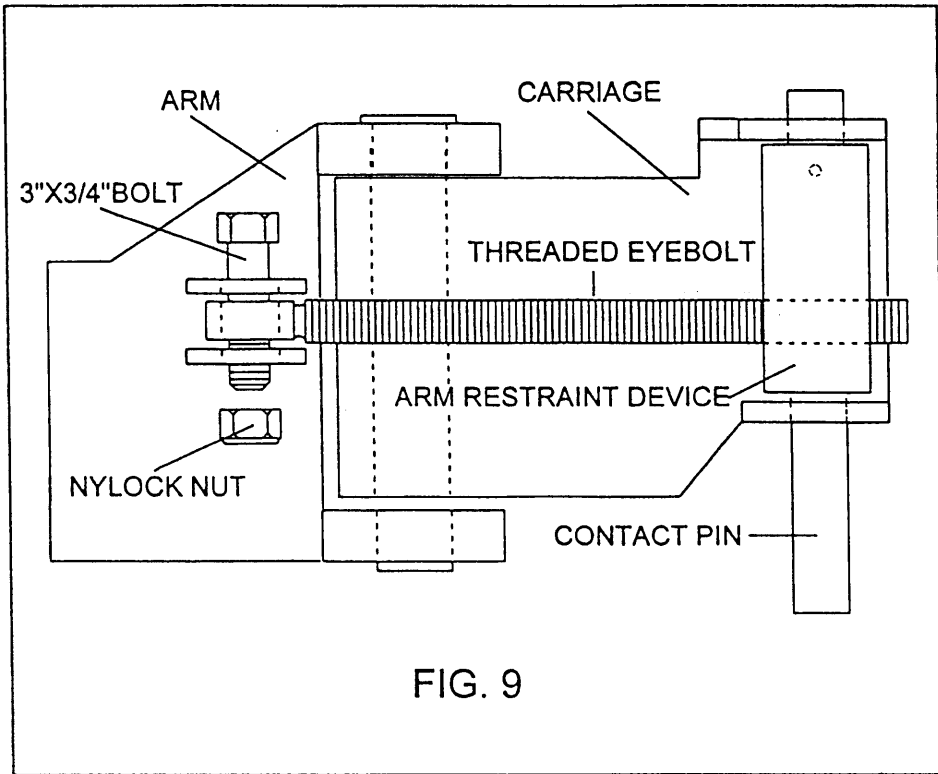

**⚠ CAUTION**

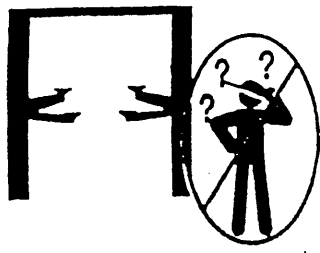

Lift to be used by trained operator only.

**⚠ CAUTION**

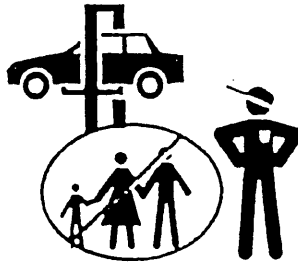

Authorized personnel only in lift area.

**⚠ WARNING**



Clear area if vehicle is in danger of falling.

**⚠ WARNING**

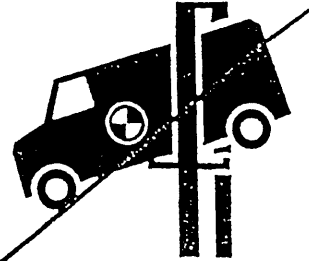

Position vehicle with center of gravity midway between adapters.

**⚠ CAUTION**

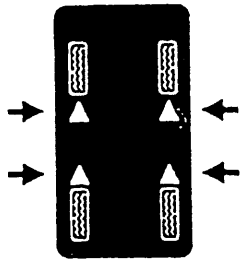

Use vehicle manufacturer's lift points.

**⚠ CAUTION**

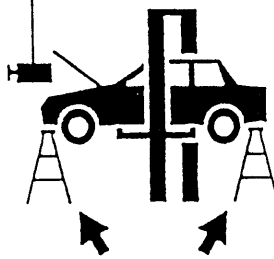

Always use safety stands when removing or installing heavy components.

**⚠ WARNING**

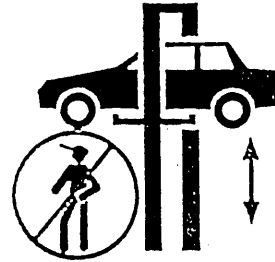

Remain clear of lift when raising or lowering vehicle.

**⚠ WARNING**

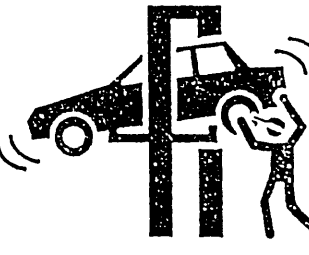

Avoid excessive rocking of vehicle while on lift.

**⚠ CAUTION**

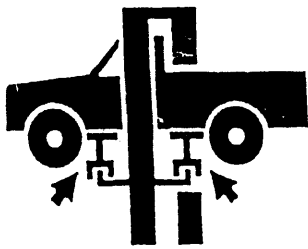

Use height extenders when necessary to ensure good contact.

**⚠ CAUTION**

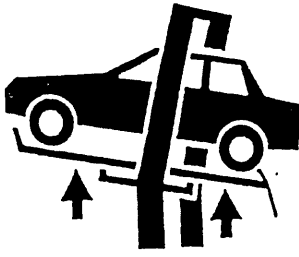

Auxiliary adapters may reduce load capacity.

**⚠ WARNING**



Do not override self-closing lift controls.

**⚠ WARNING**

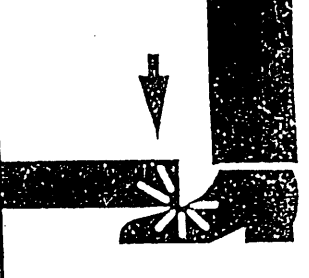

Keep feet clear of lift while lowering.

**SAFETY INSTRUCTIONS**



Read operating and safety manuals before using lift.

**SAFETY INSTRUCTIONS**

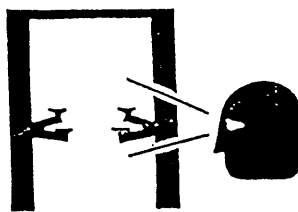

Proper maintenance and inspection is necessary for safe operation.

**SAFETY INSTRUCTIONS**

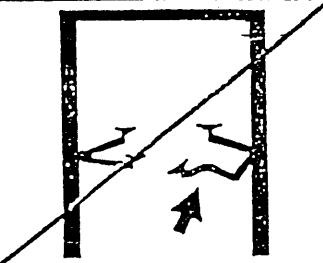

Do not operate a damaged lift.

The messages and pictographs shown are generic in nature and are meant to generally represent hazards common to all automotive lifts regardless of specific style.

Funding for the development and validation of these labels was provided by the Automotive Lift Institute, PO Box 33116 Indianapolis, FL 32903

They are protected by copyright. Set of labels may be obtained from ALI or its member companies.





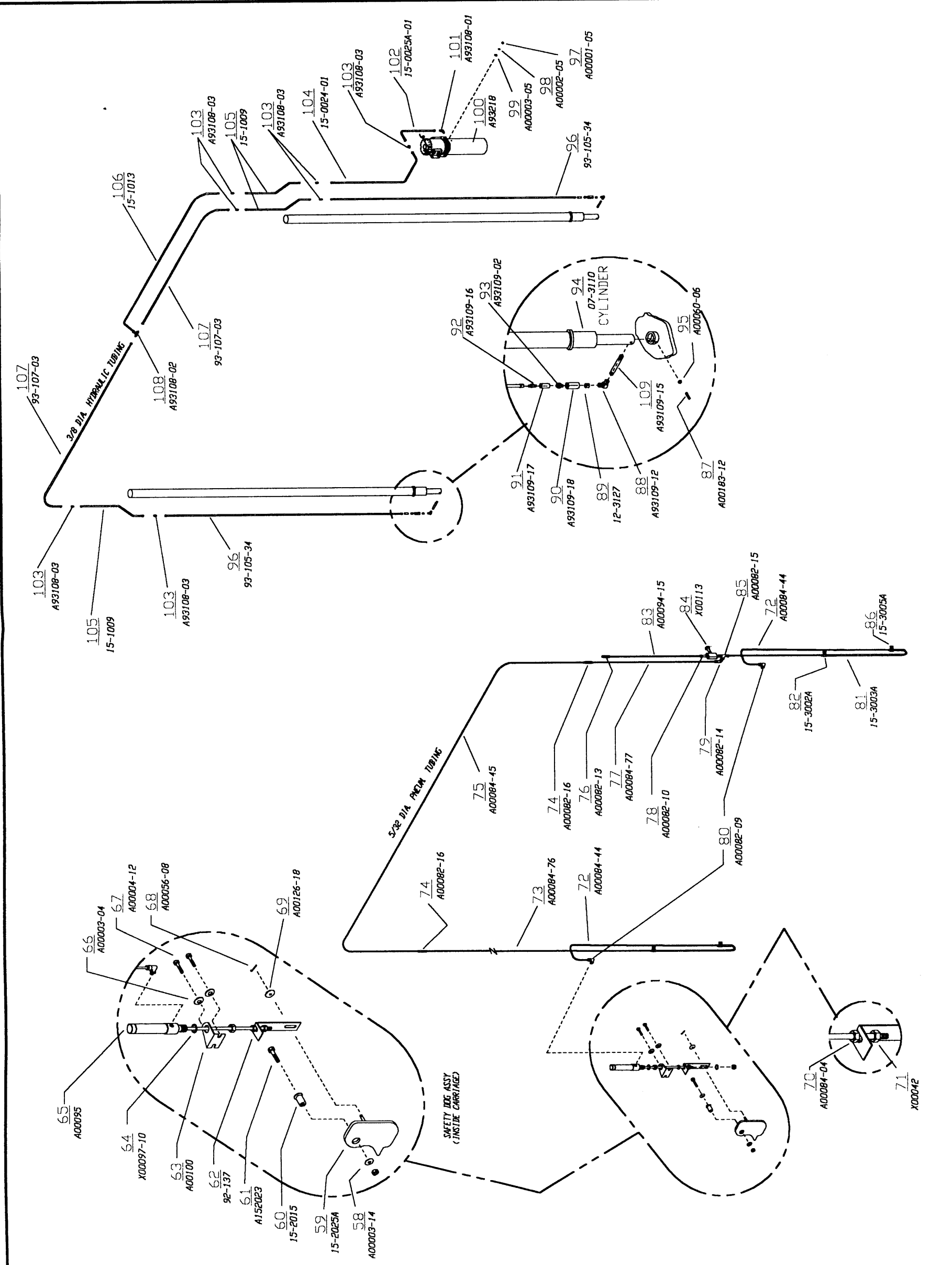

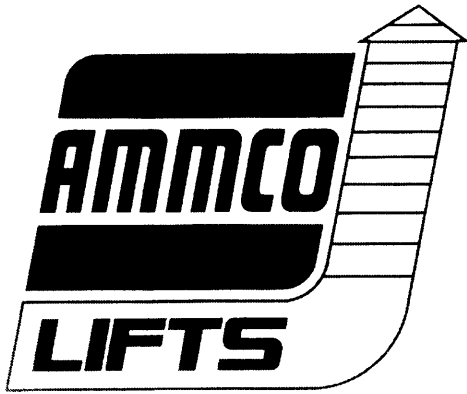

# INSTALLATION and OPERATION MANUAL

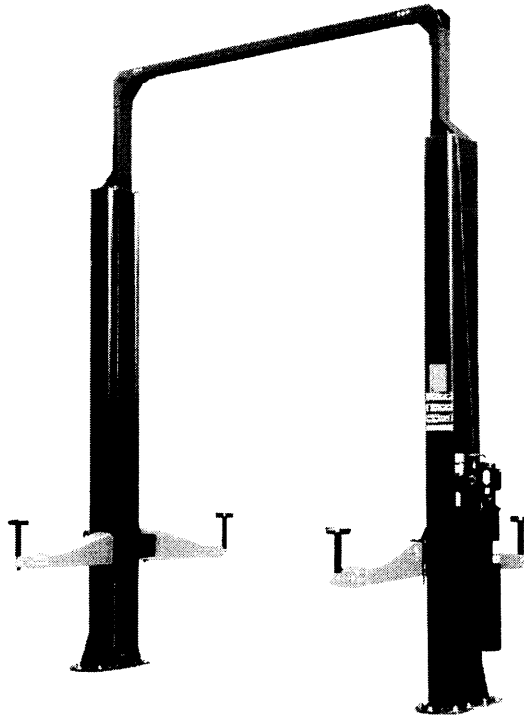

**15K 2 POST**  
**S215AR  - 1/3**

**READ and SAVE THIS  
INSTRUCTION MANUAL**

READ THIS MANUAL BEFORE INSTALLATION AND/OR OPERATION !

15001

THIS IS A VEHICLE LIFT OPERATION MANUAL AND NO ATTEMPT IS MADE OR IMPLIED HEREIN TO INSTRUCT THE USER IN LIFTING METHODS PARTICULAR TO AN INDIVIDUAL APPLICATION. RATHER, THE CONTENTS OF THIS MANUAL ARE INTENDED AS A BASIS FOR OPERATION AND MAINTENANCE OF THE UNIT AS IT STANDS ALONE OR AS IT IS INTENDED AND ANTICIPATED TO BE USED IN CONJUNCTION WITH OTHER EQUIPMENT.

PROPER APPLICATION OF THE EQUIPMENT DESCRIBED HEREIN IS LIMITED TO THE PARAMETERS DETAILED IN THE SPECIFICATIONS AND THE USES SET FORTH IN THE DESCRIPTIVE PASSAGES. ANY OTHER PROPOSED APPLICATION OF THIS EQUIPMENT SHOULD BE DOCUMENTED AND SUBMITTED IN WRITING TO AUTOMOTIVE LIFTS & MACHINERY CORP.'S EXAMINATION. THE USER ASSUMES FULL RESPONSIBILITY FOR ANY EQUIPMENT DAMAGE, PERSONAL INJURY OR ALTERATION OF THE EQUIPMENT DESCRIBED IN THIS MANUAL OR ANY SUBSEQUENT DAMAGES.

**WARNING:**

INSTALLATION OF EQUIPMENT IS HAZARDOUS. ONLY QUALIFIED PERSONNEL SHOULD PERFORM INSTALLATION PROCEDURES. INSTALLERS SHOULD FAMILIARIZE THEMSELVES WITH EQUIPMENT AND INSTALLATION PROCEDURE BEFORE ATTEMPTING INSTALLATION.

DECOMMISSION AND DISPOSAL OF PRODUCT MUST BE PERFORMED IN ACCORDANCE WITH LOCAL, STATE AND/OR FEDERAL REGULATIONS.

THE OWNER/EMPLOYER SHALL ENSURE THAT LIFT OPERATORS ARE QUALIFIED AND THAT THEY ARE TRAINED IN THE SAFE USE AND OPERATION OF THE LIFT USING THE MANUFACTURER'S OPERATING INSTRUCTIONS; ALI/SM 93-1, ALI SAFETY TIPS CARD; ANSI/ALI ALOIM-1994, AMERICAN NATIONAL STANDARD FOR AUTOMOTIVE LIFTS-SAFETY REQUIREMENTS FOR OPERATION, INSPECTION AND MAINTENANCE; ALI/WL SERIES, ALI UNIFORM WARNING LABEL DECALS/PLACARDS; AND IN THE CASE OF FRAME ENGAGING LIFTS, ALI/LP-GUIDE, VEHICLE LIFTING POINTS/QUICK REFERENCE GUIDE FOR FRAME ENGAGING LIFTS.

THE OWNER/EMPLOYER SHALL ESTABLISH PROCEDURES TO PERIODICALLY INSPECT THE LIFT IN ACCORDANCE WITH THE LIFT MANUFACTURER'S INSTRUCTIONS OR ANSI/ALI ALOIM-1994, AMERICAN NATIONAL STANDARD FOR AUTOMOTIVE LIFTS-SAFETY REQUIREMENTS FOR OPERATION, INSPECTION AND MAINTENANCE; AND THE EMPLOYER SHALL ENSURE THAT LIFT INSPECTORS ARE QUALIFIED AND THAT THEY ARE ADEQUATELY TRAINED IN THE INSPECTION OF THE LIFT.

THE OWNER/EMPLOYER SHALL ESTABLISH PROCEDURES TO PERIODICALLY MAINTAIN THE LIFT IN ACCORDANCE WITH THE LIFT MANUFACTURER'S INSTRUCTIONS OR ANSI/ALI ALOIM-1994, AMERICAN NATIONAL STANDARD FOR AUTOMOTIVE LIFTS-SAFETY REQUIREMENTS FOR OPERATION, INSPECTION AND MAINTENANCE; AND THE EMPLOYER SHALL ENSURE THAT LIFT MAINTENANCE PERSONNEL ARE QUALIFIED AND THAT THEY ARE ADEQUATELY TRAINED IN THE MAINTENANCE OF THE LIFT.

THE OWNER/EMPLOYER SHALL MAINTAIN THE PERIODIC INSPECTION AND MAINTENANCE RECORDS RECOMMENDED BY THE MANUFACTURER OR ANSI/ALI ALOIM-1994, AMERICAN NATIONAL STANDARD FOR AUTOMOTIVE LIFTS-SAFETY REQUIREMENTS FOR OPERATION, INSPECTION AND MAINTENANCE.

THE OWNER/EMPLOYER SHALL DISPLAY THE LIFT MANUFACTURER'S OPERATING INSTRUCTIONS; ALI/SM 93-1, ALI LIFTING IT RIGHT SAFETY MANUAL; ALI/ST-90 ALI SAFETY TIPS CARD; ANSI/ALI ALOIM-1994, AMERICAN NATIONAL STANDARD FOR AUTOMOTIVE LIFTS-SAFETY REQUIREMENTS FOR OPERATION, INSPECTION AND MAINTENANCE; AND IN THE CASE OF FRAME ENGAGING LIFTS, ALI/LP-GUIDE, VEHICLE LIFTING POINTS/QUICK REFERENCE GUIDE FOR FRAME ENGAGING LIFTS IN A CONSPICUOUS LOCATION IN THE LIFT AREA CONVENIENT TO THE OPERATOR.

THE OWNER/EMPLOYER SHALL PROVIDE NECESSARY LOCKOUT/TAGOUT MEANS FOR ENERGY SOURCES PER ANSI Z244.1-1982 (R1993), SAFETY REQUIREMENTS FOR THE LOCKOUT/TAGOUT OF ENERGY SOURCES, BEFORE BEGINNING ANY LIFT REPAIRS.

THE OWNER/EMPLOYER SHALL NOT MODIFY THE LIFT IN ANY MANNER WITHOUT PRIOR WRITTEN CONSENT OF THE MANUFACTURER.



AUTOMOTIVE LIFT  
SAFETY INSTRUCTIONS

PLEASE READ AND POST THESE TIPS IN A PLACE WHERE THE OPERATOR WILL BE CONSTANTLY REMINDED OF THEIR IMPORTANCE. REFER TO THE OPERATING AND INSPECTION AND MAINTENANCE INSTRUCTION.

1. WHEN POSITIONING VEHICLE, DO NOT HIT OR RUN OVER LIFT ARMS, ADAPTERS OR AXLE SUPPORTS.
2. REMOVE PASSENGERS PRIOR TO RAISING VEHICLE.
3. OPERATING VALVES, SWITCHES AND LOCKING DEVICES ARE DESIGNED FOR MAXIMUM SAFETY. NEVER ATTEMPT TO BLOCK OPEN OR OVERRIDE THEM.
4. NEVER OVERLOAD YOUR LIFT BEYOND STATED CAPACITY.
5. DO NOT ALLOW CUSTOMERS OR BY-STANDERS TO OPERATE LIFT OR TO BE IN LIFT AREA DURING ITS OPERATION. NEVER RAISE VEHICLE WITH ANYONE INSIDE IT.
6. BE SURE WORK AREA AROUND LIFT IS CLEAR - FREE OF OBSTRUCTION, DEBRIS, GREASE AND OIL.
7. NEVER ATTEMPT TO OPERATE A LIFT IF IT APPEARS TO BE MALFUNCTIONING OR IF BROKEN OR DAMAGED PARTS ARE EVIDENT.
8. LOAD LIFT CAREFULLY. CHECK TO BE SURE THE LIFTING PADS ARE IN SECURE CONTACT WITH VEHICLE BEFORE RAISING TO DESIRED WORKING HEIGHT.
9. AFTER LIFTING THE VEHICLE TO DESIRED HEIGHT, ALWAYS LOWER THE UNIT ONTO THE MECHANICAL SAFETIES. THE FORMING OF GOOD OPERATIONAL WORK HABITS WILL ELIMINATE OVERSIGHTS IN THE USE OF PROVIDED SAFETY DEVICES.
10. RELEASE LOCKING DEVICES BEFORE ATTEMPTING TO LOWER LIFT.
11. BEFORE REMOVING VEHICLE FROM LIFT AREA, POSITION ARMS, ADAPTERS OR AXLE SUPPORTS TO ASSURE THAT VEHICLE OR LIFT WILL NOT BE DAMAGED.
12. CARE MUST BE TAKEN AS BURNS CAN OCCUR FROM TOUCHING HOT PARTS.
13. DO NOT OPERATE EQUIPMENT WITH A DAMAGED CORD OR IF THE EQUIPMENT HAS BEEN DROPPED OR DAMAGED - UNTIL IT HAS BEEN EXAMINED BY A QUALIFIED SERVICEMAN.
14. DO NOT LET THE CORD HANG OVER EDGE OF TABLE, BENCH OR COUNTER OR COME IN CONTACT WITH HOT MANIFOLDS OR MOVING FAN BLADES.

**DO NOT LIFT VEHICLES OR OTHER OBJECTS IN THIS MANNER.**

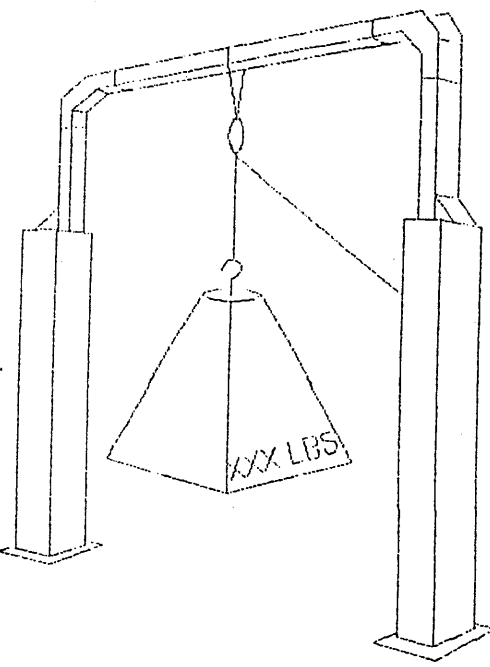
**FAILURE TO PLACE ALL FOUR ARMS PROPERLY UNDER THE VEHICLE MAY CAUSE STRUCTURAL DAMAGE NOT COVERED UNDER WARRANTY.**

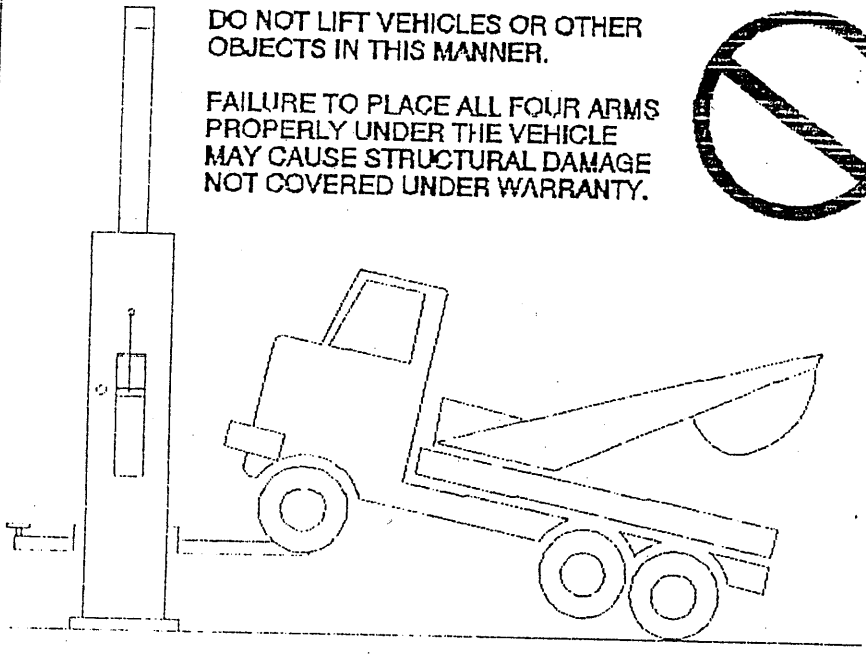

**DO NOT LIFT OR SUSPEND WEIGHT, OBJECTS OR VEHICLES FROM THE OVERHEAD STRUCTURE.**

**THIS MAY CAUSE STRUCTURAL DAMAGE NOT COVERED UNDER WARRANTY.**



## ALM CLEAR FLOOR 2 POST LIFT OPERATION INSTRUCTIONS

### TO RAISE VEHICLE:

1. LOWER CARRIAGES TO THE FLOOR POSITION.
2. RETRACT LIFTING ARMS TO MINIMUM LENGTH.
3. SWING ARMS AWAY FROM THE PATH OF THE VEHICLE. BEFORE SPOTTING THE VEHICLE, CONSULT "QUICK REFERENCE GUIDE, VEHICLE LIFTING POINTS FOR FRAME ENGAGING LIFTS" (ALI/LP-GUIDE).
4. DURING LOADING OR SPOTTING, CENTER THE VEHICLE BETWEEN THE COLUMNS AS SHOWN IN FIGURE. ALSO SEE "SPOTTING THE VEHICLE AND THE CENTER OF GRAVITY" IN THE "LIFT IT RIGHT" SAFETY MANUAL.
5. SWING THE ARMS UNDER THE VEHICLE. POSITION THE VEHICLE SUPPORT PADS AT THE VEHICLE MANUFACTURERS RECOMMENDED LIFTING POINTS. BEGINNING WITH SOME 1994 YEAR MODELS, AUTO MAKERS WILL IDENTIFY RECOMMENDED LIFT POINTS BY PLACING A LABEL ON THE VERTICAL LOCK FACE PLATE OF THE FRONT PASSENGER SIDE DOOR. (ANSI/SAE J2184-OCT92)
6. CLEAR AREA AROUND THE LIFT.
7. RAISE THE VEHICLE UNTIL THE VEHICLE SUPPORT PADS ARE IN FULL CONTACT, APPROXIMATELY 12" OFF FLOOR. CHECK TO SEE THAT VEHICLE IS STABLE ON THE LIFT BY MODERATELY ROCKING THE BUMPER. RECHECK THE POSITION OF THE PADS FOR ANY MOVEMENT.
8. RAISE THE VEHICLE TO THE DESIRED WORKING ELEVATION AND RELEASE CONTROL BUTTON.
9. LOWER TO THE SAFETY LATCHES, VEHICLE IS NOW READY FOR SERVICE.

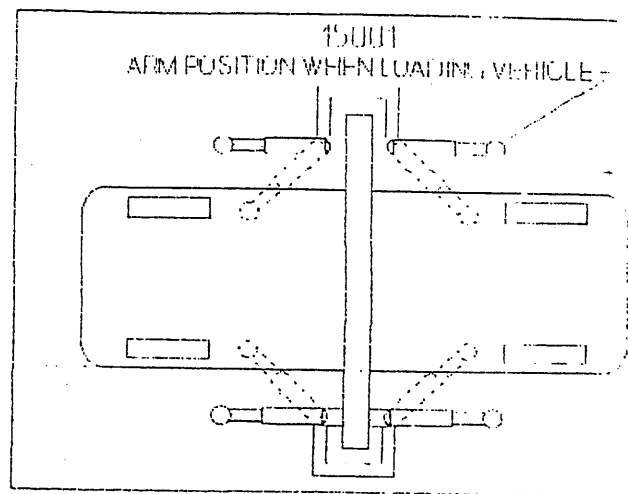

STATEMENT OF DESIGN LIMITATION. THE ALM 15001 IS A TWO-POST, FRAME ENGAGING, SURFACED MOUNTED, 15000 LBS. CAPACITY LIFT. THE INTENDED USE IS TO LIFT MOTOR VEHICLES WITHIN THE STATED CAPACITY. THE ALM 15001 IS NOT INTENDED FOR USE WITH TRANSIT, INDUSTRIAL, AGRICULTURAL OR RECREATIONAL APPLICATIONS.

SPECIAL INSTRUCTIONS FOR LONG WHEELBASE VEHICLES SUCH AS LIMOUSINES, CARGO VANS, LIGHT TRUCKS WITH TOOLBOXES, EXTENDED AND DUAL CAB LIGHT TRUCKS, ETC.

1. DO NOT LIFT WITHOUT FINDING THE VEHICLE'S CENTER OF GRAVITY.
2. DO NOT EXCEED THE STATED CAPACITY OF THE LIFT.
3. DO NOT OPERATE THE LIFT IF THE LOAD IS NOT STABLE.
4. OBSERVE OVERHEAD CLEARANCE FOR OBSTRUCTIONS WHEN LIFTING LIGHT TRUCKS WITH LADDER RACKS, CRANES, CAMPERS, ETC.
5. ALWAYS USE ALL FOUR ARMS WHEN LIFTING A VEHICLE AND FOLLOW THE VEHICLE MANUFACTURERS GUIDE LINES FOR RECOMMENDED LIFTING POINTS.
6. HEIGHT EXTENDERS MAY BE NEEDED FOR PROPER FRAME ENGAGEMENT WHEN LIFTING LIGHT TRUCKS AND VANS.
7. DO NOT USE WOOD, BRICKS, HOMEMADE EXTENDERS, ETC. USE EXTENDERS MANUFACTURED BY ALM, FOR SPECIFIC USE WITH ALM MODEL 15001.

CAUTION: SHOULD ANY MAJOR WEIGHT COMPONENT BE REMOVED OR ADDED AFTER THE VEHICLE IS RAISED, USE A JACK STAND TO SUPPORT THE OVER BALANCED END DURING THE MAINTENANCE PROCEDURE AS SHOWN IN THE FIGURE.

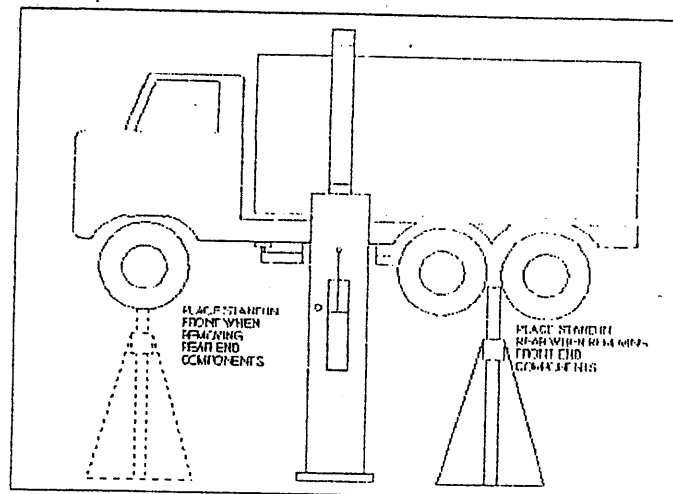

TO LOWER VEHICLES:

1. CLEAR AREA AROUND AND UNDER THE LIFT OF OBSTRUCTIONS AND WARN PERSONNEL TO STAND CLEAR.
2. RAISE VEHICLE SLIGHTLY TO REMOVE PRESSURE ON THE SAFETY LATCHES.
3. DEPRESS AIR VALVE AND PULL RELEASE LEVER ON PUMP.
4. NO ONE MUST BE UNDER THE VEHICLE WHEN LOWERING AS THE SAFETIES ARE RELEASED.
5. LOWER THE LIFT UNTIL ARMS HAVE BOTTOMED AND ARE CLEAR OF THE LIFTING POINTS.
6. SWING THE LIFTING ARMS FROM BENEATH THE VEHICLE AND FULLY RETRACT THE ARMS.
7. REMOVE THE VEHICLE.



#### IMPORTANT WARNINGS:

1. DO NOT OPERATE THE LIFT UNLESS SAFETY LATCHES ARE FUNCTIONING AS EVIDENCED BY THE SAFETY LATCHES DROPPING INTO THE SAFETY LADDER SLOTS DURING THE RAISING MOTION.
2. DO NOT OPERATE THE LIFT IF THE LOAD TILTS OR BINDS DURING THE UP OR DOWN MOVEMENT.
3. ALWAYS USE ALL FOUR ARMS WHEN LIFTING A VEHICLE AND FOLLOW THE VEHICLE MANUFACTURERS GUIDE LINES FOR RECOMMENDED LIFTING POINTS.

#### INSPECTION AND MAINTENANCE PROCEDURES

THE SCHEDULE IS BASED ON CONDITIONS FOUND IN THE USUAL AUTOMOTIVE SERVICE ENVIRONMENT UNDER NORMAL USAGE (APPROXIMATELY 12000 CYCLES PER YEAR). IN CASES OF HIGH VOLUME OPERATION OR AREAS WITH A HIGH DENSITY OF AIRBORNE DEBRIS, THE SCHEDULE MUST BE ACCELERATED.

1. SAFETY LATCH WORKING / CHECK DAILY / ADJUST CABLE TENSION IF OUT OF SYNCHRONIZATION.
2. ARM PINS / CHECK SEMI-ANNUAL / LUBE EVERY 6 MONTHS WITH GREASE.
3. RUBBER LIFT PADS / REPLACE IF SEVERELY DAMAGED
4. ARM RESTRAINT RODS / CHECK MONTHLY / KEEP THREADS CLEAN AND RUST FREE.
5. SPINDLE PADS / CHECK MONTHLY / KEEP THREADS CLEAN AND RUST FREE. USE LIGHT OIL.
6. COLUMN ANCHOR BOLTS / CHECK QUARTERLY / CHECK WEEKLY IN THE FIRST MONTH OF OPERATION, MIN 150 FT. LBS. OF TORQUE. IF UNABLE TO TIGHTEN SUSPEND USE OF LIFT AND CONTACT FACTORY.
7. FLOOR CRACKS EMULATING FROM UNDER COLUMNS / CONTACT FACTORY
8. STRUCTURAL WEAR, CRACKS OR VISUALLY OUT OF PLUMB / CONTACT FACTORY
9. EQUALIZATION CABLE / CHECK SEMI-ANNUAL / SEE PAGE FOR INSPECTION PROCEDURE.
10. CARRIAGE BEARINGS / CHECK SEMI-ANNUAL / GREASE WITH LITHIUM RP #2. REPLACE BEARINGS WHEN CLEARANCE BETWEEN BEARING MOUNTING PLATES AND COLUMN IS LESS THAN 1/16".
11. HYDRAULIC FLUID / REPLACE EVERY TWO YEARS WITH CITGO A/W 46 OR EQUAL.

## EQUALIZATION CABLE INSPECTION

WITHOUT LOAD RAISE THE LIFT IN INCREMENTS THAT WILL ALLOW INSPECTION OF THE ENTIRE CABLE. IF THE FOLLOWING CONDITIONS EXIST REPLACE THE CABLE.

1. WHEN ITS DIAMETER IS LESS THAN  $1\frac{1}{32}$ ".
2. IF 3 OR MORE ELEMENT WIRES ARE BROKEN IN 1 STRAND.
3. IF 6 OR MORE ELEMENT WIRES ARE BROKEN IN A STRAND LAY.
4. BADLY DEFORMED OR RUSTED.
5. BROKEN WIRES AT THE CONNECTION TO THREADED RODS.

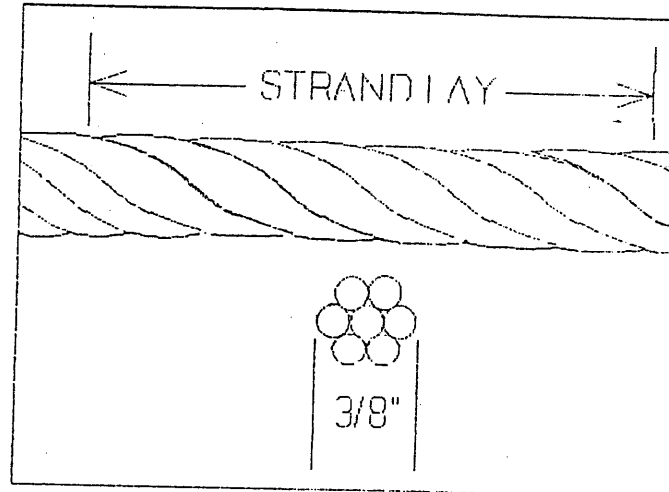

INSPECT THE LOWER COLUMN AND VERTICAL PROFILE PULLEYS FOR BROKEN FLANGES, EXCESSIVE WEAR IN THE GROOVE, BUSHING OR AXLE. ANNUALLY LUBRICATE THE ENTIRE CABLE WITH LIGHT OIL.

I M P O R T A N T   N O T I C E ! !

THE FLOOR ON WHICH THE LIFT IS TO BE INSTALLED MUST BE A MINIMUM THICKNESS OF 4" REINFORCED CONCRETE WITH A MINIMUM COMPRESSIVE STRENGTH OF 4000 PSI

FAILURE BY THE PURCHASER TO PROVIDE THE RECOMMENDED MOUNTING SURFACE COULD RESULT IN UNSATISFACTORY LIFT PERFORMANCE, PROPERTY DAMAGE OR PERSONAL INJURY.

GENERAL TOOLS FOR INSTALLATION:

ROTARY HAMMER DRILL WITH 3/4" SOLID DRILL BIT WITH CARBIDE TIP LEVEL  
HAND SLEDGE  
PRY BAR  
TAPE MEASURE  
CHALK LINE  
12' LADDER  
SHORTENED 1/16" OPEN-END WRENCH  
VISE GRIPS  
SNAP RING PLIERS  
1 1/16" OPEN END WRENCH  
5/8" OPEN END WRENCH  
9/16" SOCKET AND SUITABLE RATCHET  
7/16" SOCKET AND SUITABLE RATCHET  
1/2" SOCKET AND SUITABLE RATCHET  
1 1/8" DEEP SOCKET AND SUITABLE RATCHET  
4 GAL. HYDRAULIC FLUID - CITGO A/W 46 OR SUITABLE CROSS-REFERENCE

## ALM 15001 CLEAR FLOOR 2 POST LIFT INSTALLATION MANUAL

### COLUMN PLACEMENT

1. PLACEMENT OF LIFT SHOULD BE AT LEAST 12' FROM NEAREST OBSTACLE, FRONT TO REAR, PLUS ANY DESIRED AISLE OR WORK AREA BETWEEN VEHICLE AND OBSTACLE SUCH AS GARAGE DOOR, WORK BENCH, ETC. PLACE A CHALK LINE AT THE SELECTED LOCATION, ERECT BOTH COLUMNS IN THEIR RESPECTIVE LOCATIONS OUTSIDE BASEPLATE TO BASEPLATE AND SQUARE TO CHALK LINE. THE CONTROL COLUMN MAY BE PLACED ON EITHER SIDE. (SEE FIG. 1).
2. AT THIS TIME INSTALL THE AIR VALVE WITH THE PRE-ASSEMBLED AIR FITTINGS INTO THE SMALL HOLE AT THE LOWER LEFT OF THE 4 MOTOR MOUNTING STUDS ON THE CONTROL COLUMN. THE PALM BUTTON AND LOCKNUTS MUST BE REMOVED FOR THE VALVE STEM TO PASS THRU THE HOLE. REASSEMBLE ONCE THRU THE HOLE (SEE FIG. 2). CONNECT THE 2 PRE-ASSEMBLED AIR HOSES INSIDE THE CONTROL COLUMN TO THE AIR VALVE BY PUSHING THE 1/4" AIR HOSE INTO THE TOP FITTING AND PUSHING THE 5/32" AIR HOSE TO THE BOTTOM FITTING. CONNECT THE 5/32 X 94 3/4" AIR HOSE (IN HARDWARE KIT) TO THE 90 DEGREE FITTING ON THE AIR VALVE.

UNFOLD METAL TABS HOLDING EXSISTING STEEL HYDRAULC TUBE IN CONTROL COLUMN. INSTALL THE DOUBLE 90 DEGREE STEEL HYDRAULIC TUBE THROUGH THE LARGE HOLE FROM THE INSIDE THE COLUMN. (SEE FIG 7).

3. BEGINNING WITH THE CONTROL COLUMN, MANUALLY RAISE THE CARRIAGE TO THE 2ND SAFETY CATCH AND STOP. DRILL HOLES AND INSTALL CONCRETE ANCHOR BOLTS, BUT DO NOT TIGHTEN UNTIL COLUMN HAS BEEN LEVELED, SHIM IF NECESSARY. IF SHIMS EXCEED 1/2", CONTACT FACTORY. TIGHTEN ANCHOR BOLTS A MIN. OF 150 FT. LBS. DO NOT INSTALL ANCHOR BOLTS FOR OPPOSITE CONTROL COLUMN AT THIS TIME.
4. VERTICAL PROFILE ADJUSTMENT (IF REQUIRED)

A CEILING HEIGHT OF 195" INCHES OR MORE IS REQUIRED TO INSTALL 15001 LIFT AS IT COMES STOCK FROM THE FACTORY (SEE FIG.3).

TO INSTALL VERTICAL PROFILES IN LESS THAN 195" INCHES, MEASURE FROM FLOOR TO CEILING (OR ANY OBSTACLE SUCH AS LIGHT FIXTURE, HEATER, ETC.) AND SUBTRACT A MINIMUM OF 2" FOR HORIZONTAL PROFILE CLEARANCE. NEXT, SUBTRACT THIS MEASUREMENT FROM 193" INCHES. THIS DETERMINES THE DISTANCE THE VERTICAL PROFILES ARE TO BE LOWERED. SEE EXAMPLE ON NEXT PAGE.



7. VERTICAL AND HORIZONTAL PROFILE INSTALLATION

FIRST REMOVE 2 OF THE 6 BOLTS (1 FROM EACH SIDE OF THE SMALL SLOT) LOCATED ON THE CONTROL COLUMN TOP PLATE. PLACE THE VERTICAL PROFILE ON THE TOP PLATE AND REPLACE THE 2 BOLTS. INSTALL THE 3/8" X 1-1/2" BOLTS WITH FLAT WASHERS, LOCK WASHERS AND NUTS IN THE REMAINING 4 HOLES. DO NOT TIGHTEN BOLTS AT THIS TIME.

INSTALL REMAINING VERTICAL PROFILE ON OPPOSITE COLUMN. DO NOT TIGHTEN PROFILE BOLTS AT THIS TIME.

INSTALL HORIZONTAL PROFILE USING 3/8 X 1-1/4" NUTS AND BOLTS, FLAT WASHERS AND LOCKWASHERS. DO NOT TIGHTEN AT THIS TIME.

8. CONFIRM CORRECT COLUMN PLACEMENT DIMENSION (SEE FIG. 1).
9. MANUALLY RAISE THE OPPOSITE CONTROL COLUMN CARRIAGE AS DESCRIBED IN STEP 3. NOTE : BOTH CARRIAGES MUST BE AT THE SAME HEIGHT. DRILL HOLES AND INSTALL CONCRETE ANCHOR BOLTS. LEVEL SHIM IF NECESSARY. TIGHTEN ANCHOR BOLTS.
10. TIGHTEN ALL OVERHEAD VERTICAL AND HORIZONTAL PROFILE BOLTS.
11. CABLE INSTALLATION

CONFIRM THAT BOTH CARRIAGES ARE OF EQUAL HEIGHT. STAND FACING THE CARRIAGE OF THE CONTROL COLUMN. BEGINNING WITH THE SHORT THREADED CABLE ROD, RUN THE CABLE UP AND OVER THE VERTICAL PROFILE PULLEY, THROUGH THE HORIZONTAL PROFILE TO THE OPPOSITE COLUMN, DOWN THROUGH THE CARRIAGE, AROUND THE BOTTOM COLUMN PULLEY AND UP THROUGH HOLE IN THE BOTTOM OF THE CARRIAGE. THE BOTTOM COLUMN PULLEY MUST BE REMOVED AND REPLACED. CONTINUE TO RUN THE CABLE UP AND OUT THE TOP OF THE CARRIAGE. THREAD THE 3/4 X 10 NYLOCK NUT ALL THE WAY ON THE SHORT THREADED ROD (SEE FIG. 4 THRU 6). PULL THE CABLE WITH THE SHORT ROD BACK DOWN TO ITS NORMAL POSITION. INSERT THE LONG THREADED ROD THROUGH HOLE ON TOP OF CARRIAGE AND THREAD 3/4 X 10 NYLOCK NUT ON BY HAND AS FAR AS POSSIBLE. DO NOT TIGHTEN AT THIS TIME. REPEAT THE ABOVE FOR 2ND CABLE. TO COMPLETE TIGHTENING OF THE CABLES, PLACE A VISE GRIP AT LEAST 6" ABOVE THE 3/4 X 10 NYLOCK NUT ON THE LONG THREADED ROD AND A 1 1/16" WRENCH ON THE 3/4 X 10 NYLOCK NUT. TURN THE ROD WITH THE VISE GRIP TO THREAD NYLOCK NUT ON ROD. TIGHTEN EACH CABLE UNTIL APPROXIMATELY 1/2" DEFLECTION IS PRESENT MIDPOINT IN THE CABLE. IF BOTH SAFETY LATCHES FALL IN AT THE SAME TIME ONCE THE LIFT IS OPERATED UP, NO FURTHER CABLE ADJUSTMENT IS NEEDED.

12. HYDRAULIC TUBES & AIR LINE

MOUNT POWER UNIT TO STUDS ON THE CONTROL COLUMN. INSTALL THE MALE 90° DEGREE HYDRAULIC FITTING (FIROW) INTO THE POWER UNIT WITH THE OPENING POINTED DOWN. CONNECT THE FLEXIBLE HYDRAULIC HOSE TO THE FITTING ON THE POWER UNIT. CONNECT THE FLEXIBLE HOSE TO THE DOUBLE 90° DEGREE STEEL HYDRAULIC TUBE. (SEE FIG. 7 & 8). INSTALL ONE OF TWO VERTICAL PROFILE HYDRAULIC TUBES. NOTE, THE AIR LINE FOLLOWS THE SAME ROUTE AS THE HYDRAULIC TUBING. STARTING WITH THE CONTROL SIDE, FEED THE COIL OF 5/32" AIR HOSE THROUGH THE SMALL SLOT IN THE COLUMN TOP. TAPE THE AIR HOSE TO THE SECOND VERTICAL PROFILE HYDRAULIC TUBE AND USE IT AS A GUIDE TO ROUTE THE AIR LINE THROUGH THE VERTICAL PROFILE.

UNTape THE AIR LINE AND PULL REMAINING LINE THROUGH THE VERTICAL PROFILE. ASSEMBLE THE THREE HORIZONTAL PROFILE HYDRAULIC TUBES TO THE TEE. TIGHTEN ALL FITTINGS. USING THE HORIZONTAL PROFILE HYDRAULIC TUBE AS A GUIDE, TAPE THE AIR LINE TO THE OPPOSITE THE CONTROL SIDE END OF THE HYDRAULIC TUBE AND INSTALL.

UNTape THE AIR LINE AND PULL THE REMAINING LINE THROUGH THE HORIZONTAL PROFILE. FEED THE AIR LINE DOWN THROUGH THE VERTICAL PROFILE, THROUGH THE SMALL HOLE IN THE COLUMN TOP PLATE AND CONNECT IT TO THE PRE-ASSEMBLED 5/32 STRAIGHT COUPLER AT THE TOP OF THE COLUMN. INSTALL THE REMAINING VERTICAL PROFILE HYDRAULIC TUBE AND TIGHTEN ALL REMAINING HYDRAULIC FITTINGS. USE WIRE TIES TO SECURE THE AIR LINE TO THE HYDRAULIC TUBE. CONNECT EITHER A TEMPORARY OR PERMANENT AIR SUPPLY TO THE 1/4" NPT AIR INTAKE ON THE CONTROL COLUMN TOP PLATE.

13. LIFT ARMS

EACH LIFT ARM HAS AN EYEBOLT BRACKET FOR THE THREADED EYEBOLT. THIS BRACKET SHOULD CORRESPOND WITH THE ARM RESTRAINT DEVICE LOCATED ON THE SIDE OF THE CARRIAGE. GREASE AND INSTALL ARM AXLES. ATTACH SNAP RING ON BOTTOM OF AXLE. INSERT THE THREADED EYEBOLT INTO ARM-RESTRAINT DEVICE BY PUSHING UP ON THE ARM-RESTRAINT CONTACT PIN LINE UP EYEBOLT HOLE WITH BRACKET ON ARM AND INSERT THE 3/4 X 3" BOLT FROM THE TOP, SECURE WITH 3/4" NYLOCK NUT (SEE FIG. 9).

14. ESTABLISH ELECTRICAL POWER 220 VOLT, SINGLE PHASE. USE 10 GA. WIRE WITH 2 POLE 30 AMP BREAKER (SEE FIG. 10).

15. SAFETY CABLE

ATTACH ONE END OF THE SAFETY CABLE TO THE EYE ON THE OPPOSITE CONTROL SIDE VERTICAL PROFILE USING THE 1/16" CABLE CRIMPS SUPPLIED. RUN CABLE THROUGH THE GUIDE ON CONTROL SIDE VERTICAL PROFILE AND GUIDE ON TOP OF CONTROL SIDE COLUMN TO THE SAFETY LIMIT SWITCH ACTIVATOR ON POWER UNIT AND FASTEN. TRIM ANY EXCESS CABLE.

16. OPERATE THE LIFT UP UNTIL BOTH HYDRAULIC CYLINDERS CONTACT THE CARRIAGES. EACH CYLINDER HAS A BLEED SCREW LOCATED ON THE TOP OF THE CYLINDER BARREL. OPEN THE BLEED SCREWS ONE FULL TURN. THIS ALLOWS THE AIR TO BE PUSHED OUT AS THE CYLINDER FILLS WITH OIL. DO NOT COMPLETELY REMOVE THE BLEED SCREWS. WHEN A SOLID STREAM OF OIL IS PRESENT CLOSE THE BLEED SCREWS. OPERATE THE LIFT TO FULL HEIGHT.

TO LOWER, DEPRESS THE AIR VALVE PALM BUTTON ON THE COLUMN AND THE HYDRAULIC RELEASE LEVER ON THE PUMP. RAISE AND LOWER LIFT SEVERAL TIMES, THEN CHECK THE FOLLOWING:

- A) BOTH SAFETY LATCHES FALL IN AT THE SAME TIME.
- B) BOTH SAFETY LATCHES RELEASE PROPERLY.
- C) HYDRAULIC LEAKS.
- D) ARM - RESTRAINT FUNCTION PROPERLY.
- E) ANCHOR BOLT AND ALL OTHER NUTS AND BOLTS ARE TIGHT.
- F) SAFETY LIMIT FUNCTIONS PROPERLY.



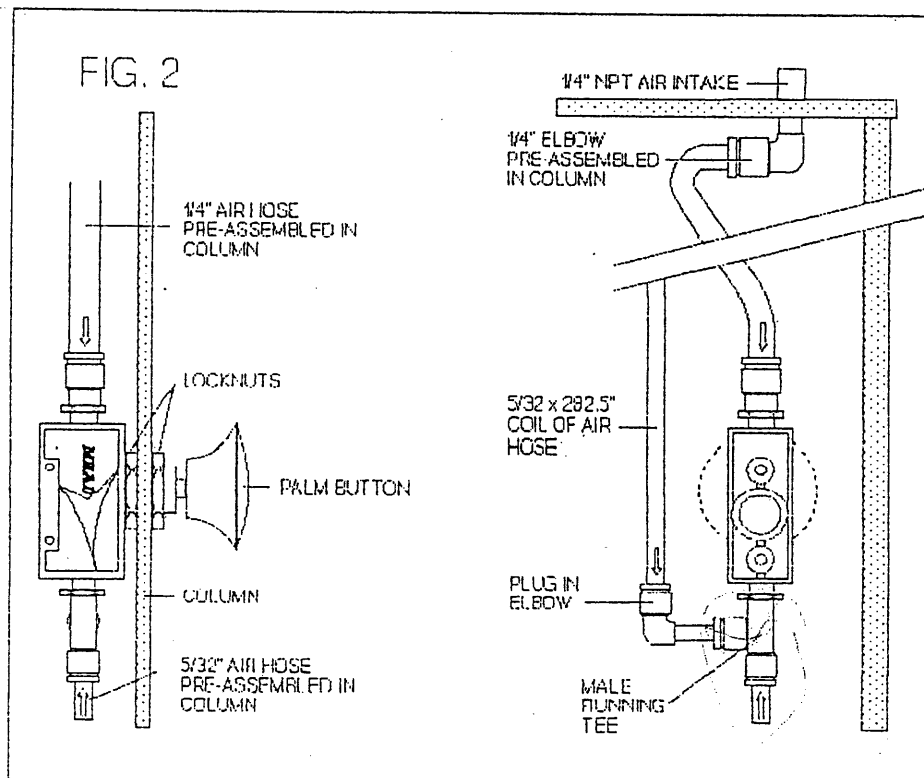
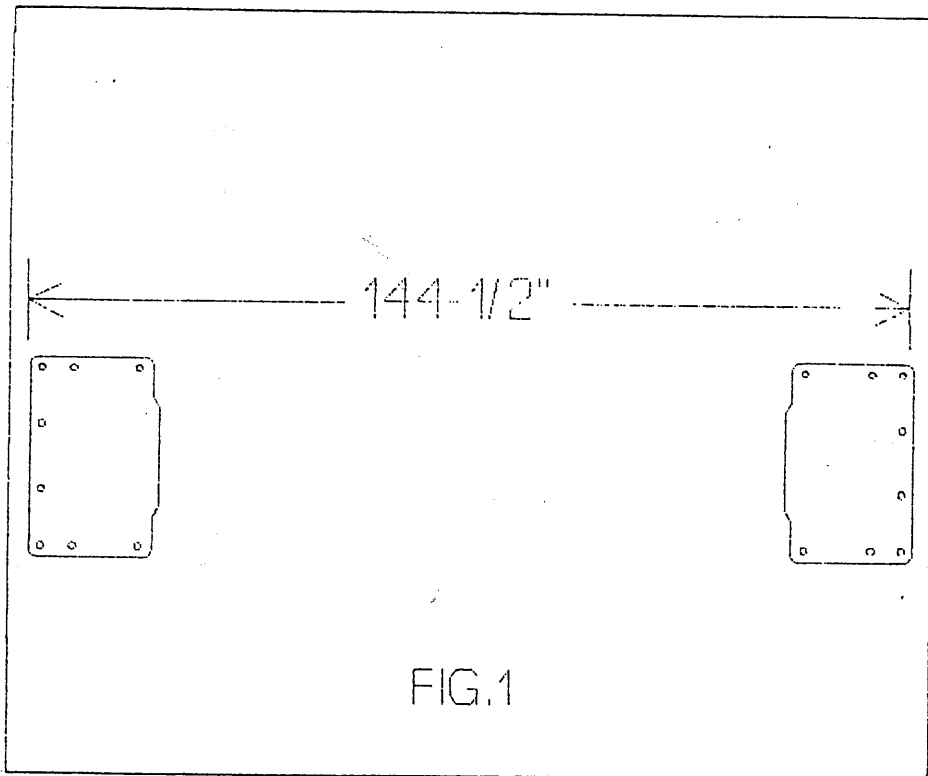

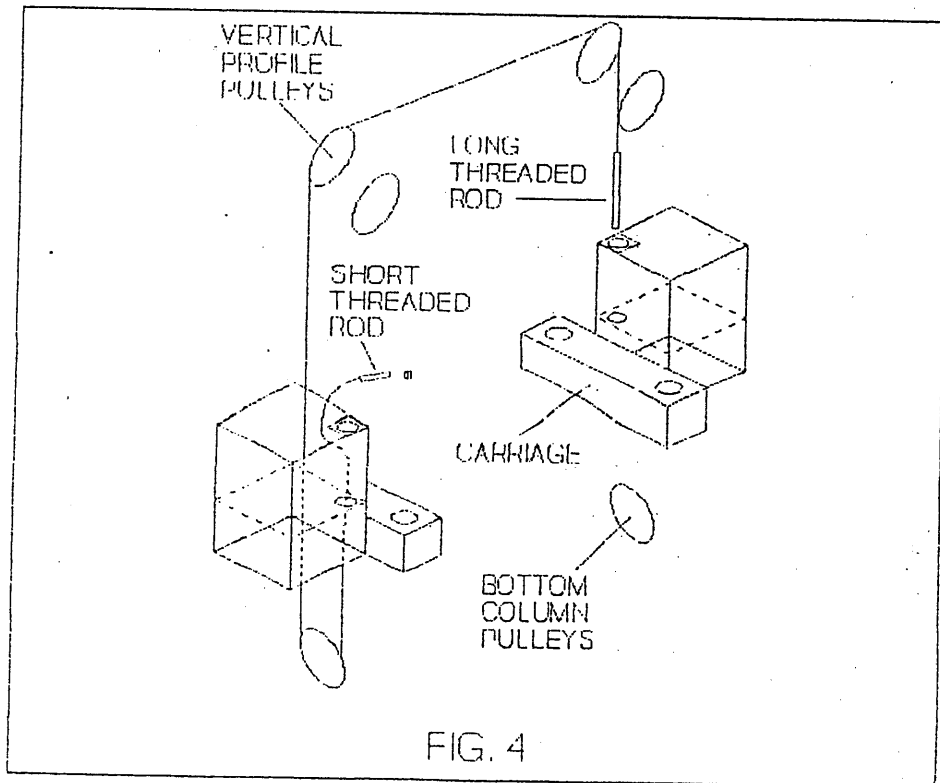
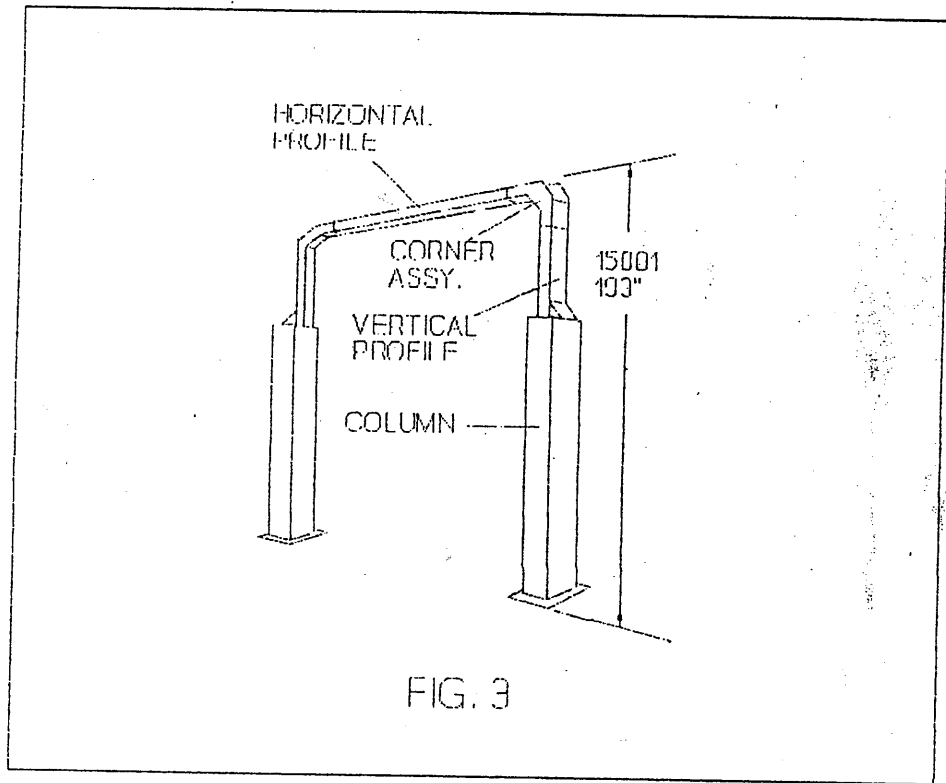

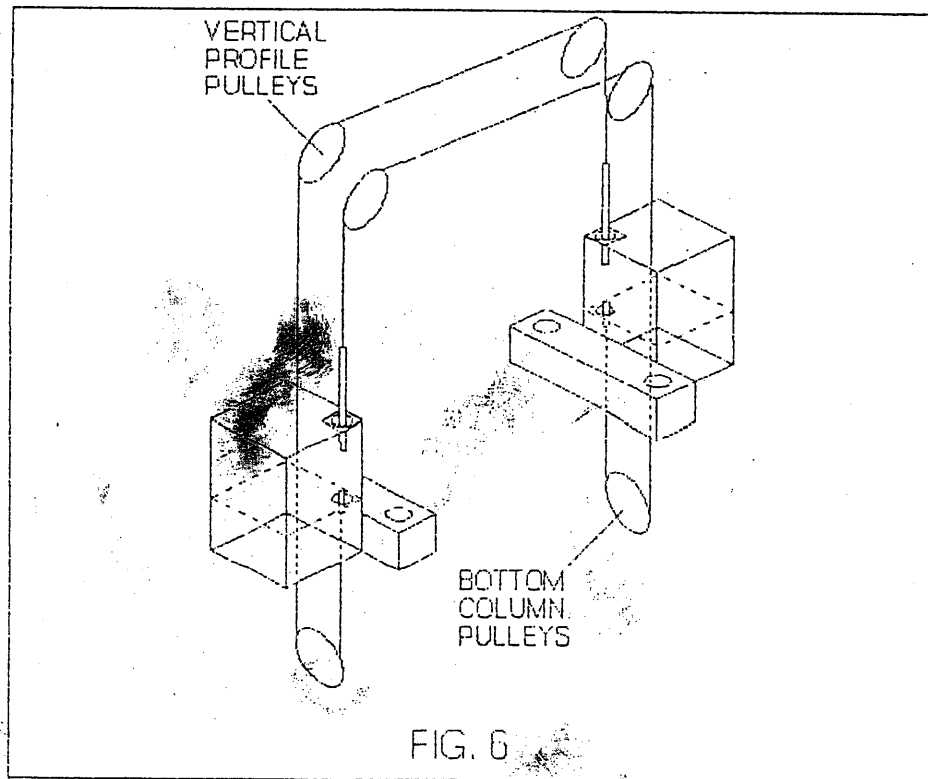
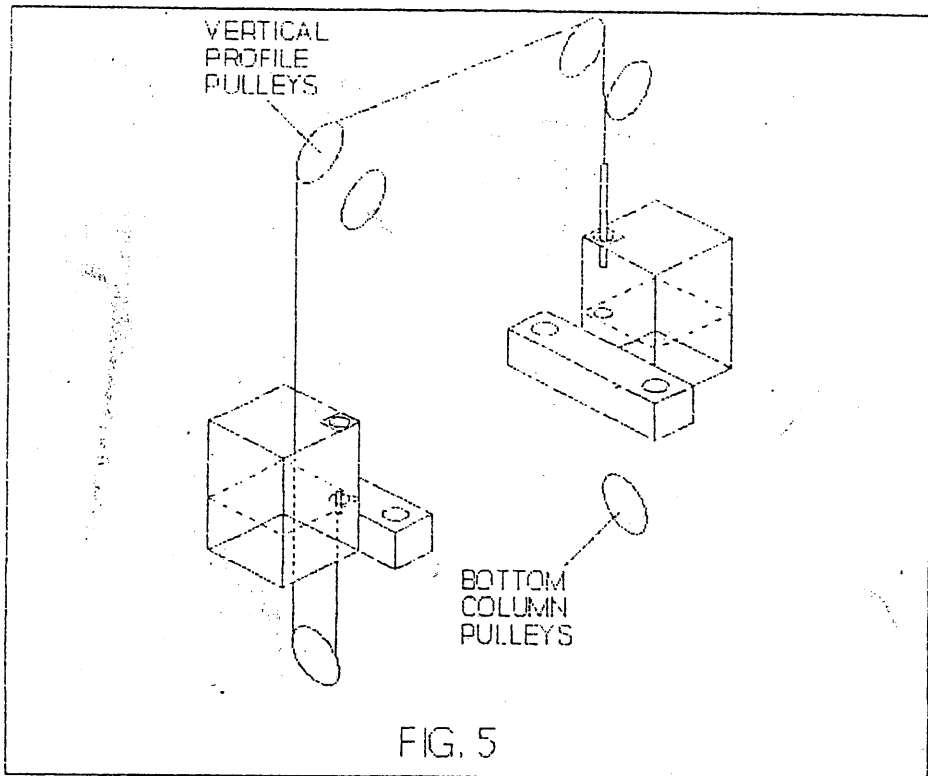

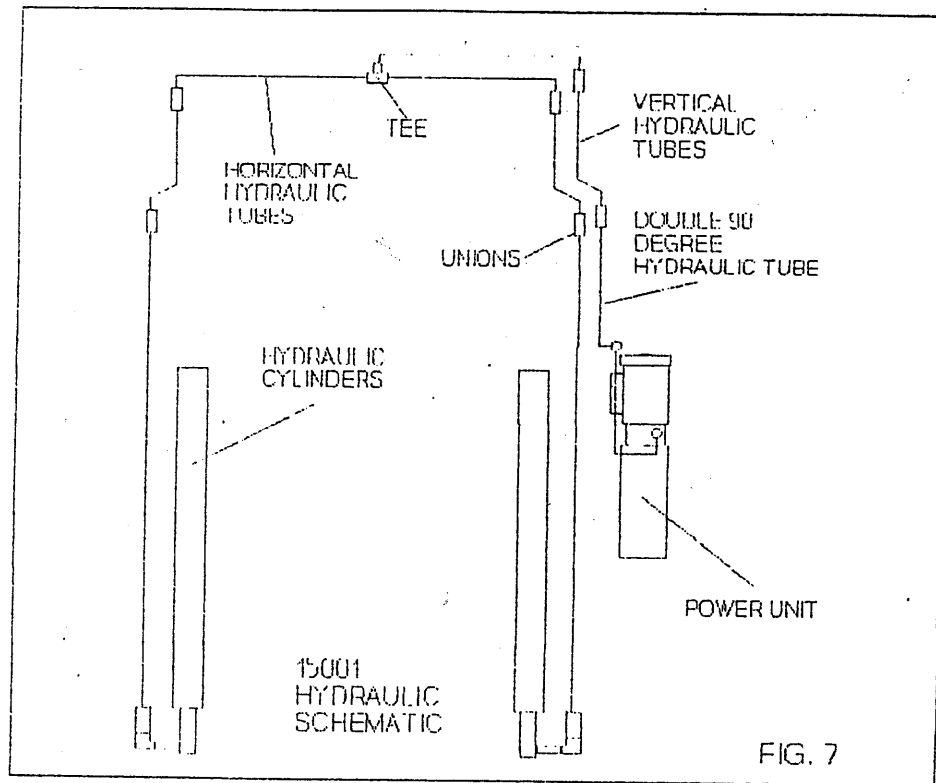

FIG. 7

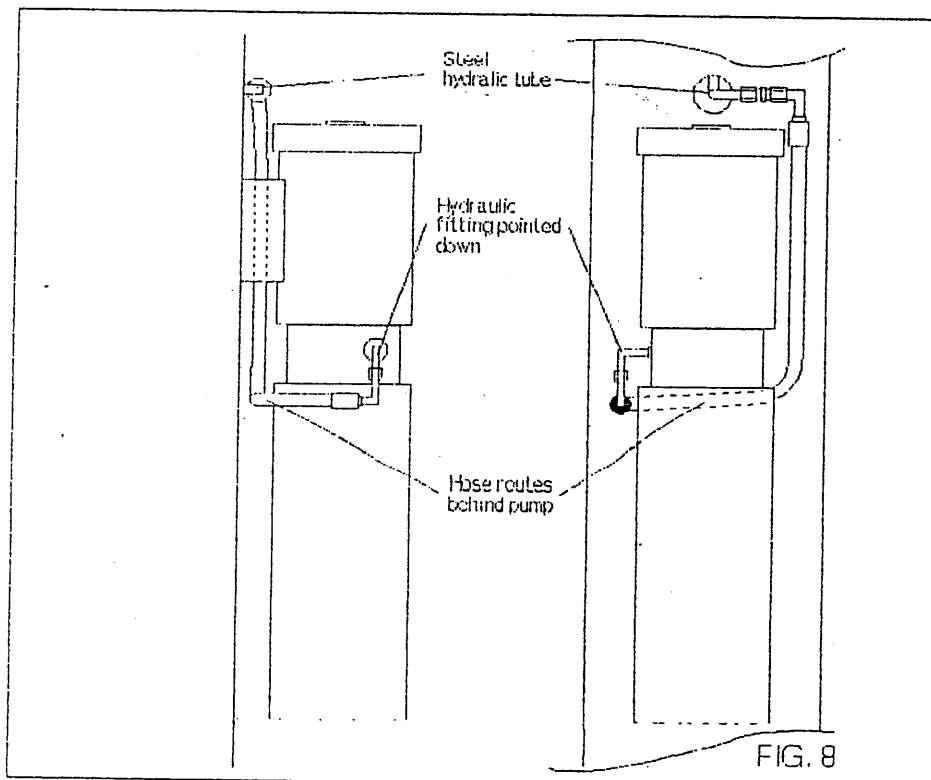

FIG. 8

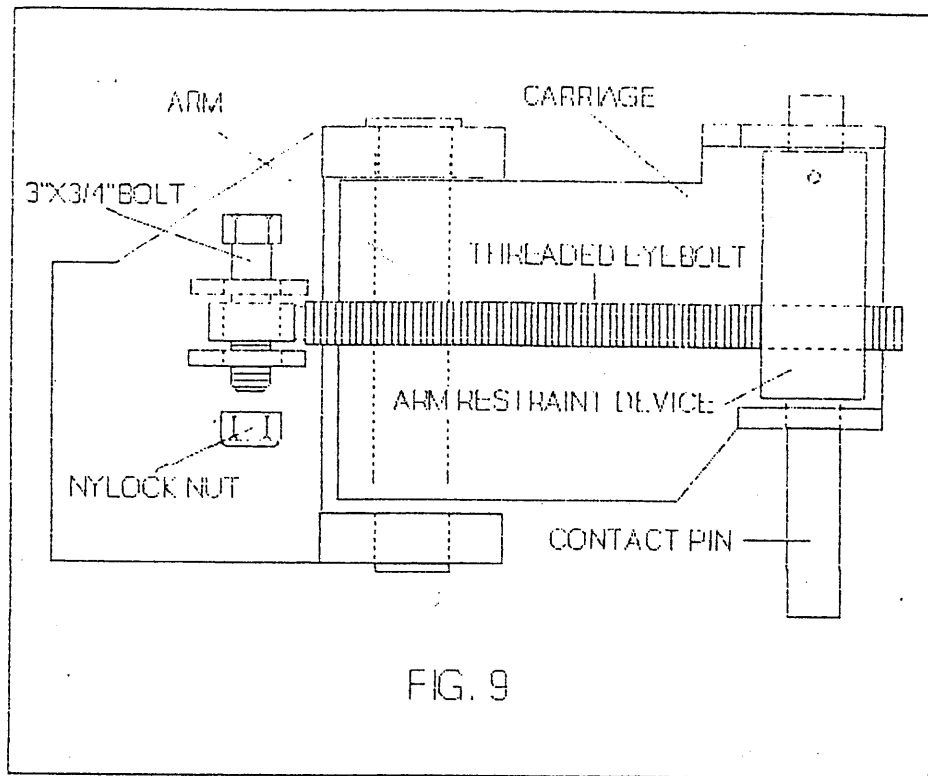
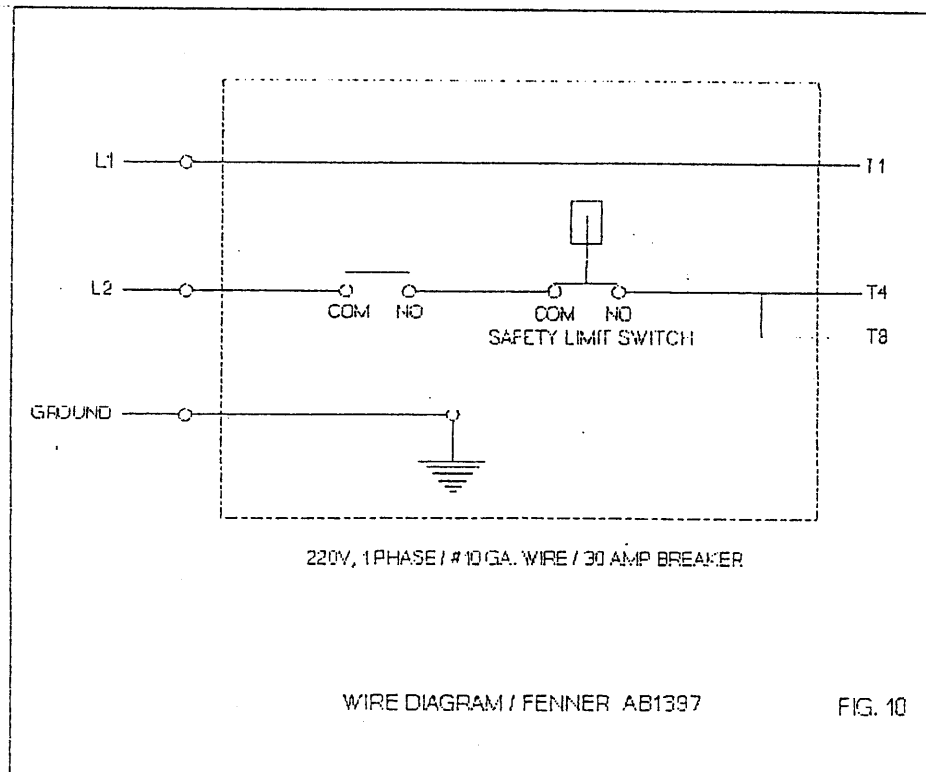

FIG. 9



WIRE DIAGRAM / FENNER AB1397

FIG. 10

ALM TWO POST  
TROUBLE SHOOTING

PROBLEM	CAUSE	SOLUTION
Electric motor does not run.	<ol style="list-style-type: none"> <li>1. Check fuse or circuit breaker.</li> <li>2. Check for correct voltage to motor.</li> <li>3. Inspect all wiring connections.</li> <li>4. Operation switch burned out.</li> <li>5. Overhead limit switch burned out.</li> <li>6. Motor windings burned out.</li> </ol>	<ol style="list-style-type: none"> <li>1. Replace blown fuse or reset circuit breaker.</li> <li>2. Supply correct voltage to motor.</li> <li>3. Repair and insulate all connections.</li> <li>4. Replace switch.</li> <li>5. Replace switch.</li> <li>6. Replace motor.</li> </ol>
Electric motor runs but will not raise lift.	<ol style="list-style-type: none"> <li>1. Motor runs in reverse rotation.</li> <li>2. Plugged suction screen.</li> <li>3. Open Lowering valve.</li> <li>4. Pump sucking air.               <ol style="list-style-type: none"> <li>A) Loose or cracked suction line.</li> </ol> </li> <li>5. Low oil level.</li> </ol>	<ol style="list-style-type: none"> <li>1. Change motor rotation.</li> <li>2. Replace or clean suction screen.</li> <li>3. Repair or replace lowering valve.</li> <li>4. Tighten all suction line fittings.               <ol style="list-style-type: none"> <li>A) Repair or replace.</li> </ol> </li> <li>5. Fill tank with AW 46 hyd. fluid.</li> </ol>
Electric motor runs or raises unloaded but will not raise vehicle.	<ol style="list-style-type: none"> <li>1. Motor running on low voltage.</li> <li>2. Debris in lowering valve.</li> <li>3. Improper relief valve adjustment.</li> <li>4. Overloading lift.</li> </ol>	<ol style="list-style-type: none"> <li>1. Supply correct voltage to motor.</li> <li>2. Clean lowering valve.</li> <li>3. Consult factory.</li> <li>4. Check vehicle weight and/or balance vehicle weight on lift.</li> </ol>
Lift slowly settles down.	<ol style="list-style-type: none"> <li>1. External oil leaks.</li> <li>2. Debris in lowering valve seat.</li> <li>3. Debris in check valve seat.</li> </ol>	<ol style="list-style-type: none"> <li>1. Repair external leaks.</li> <li>2. Clean or replace lowering valve.</li> <li>3. Consult factory.</li> </ol>
Slow lifting speed or oil blowing out filler breather cap.	<ol style="list-style-type: none"> <li>1. Air mixed with oil.</li> <li>2. Oil return tube loose.</li> <li>3. System overfilled.</li> <li>4. Obstruction in return filter.</li> </ol>	<ol style="list-style-type: none"> <li>1. a. Change oil (AW 46 Hyd. Fluid). b. Tighten all suction line fittings.</li> <li>2. Reinstall return tube.</li> <li>3. Check oil level, remove excess.</li> <li>4. Remove obstruction and replace filter.</li> </ol>
Power unit noisy	<ol style="list-style-type: none"> <li>1. Sucking air and oil. (Foamy oil causing cavitation)</li> <li>2. Power unit loose on column.</li> <li>3. Worn motor coupling.</li> <li>4. Plugged suction filter</li> </ol>	<ol style="list-style-type: none"> <li>1. Change out old oil with new AW 46 hydraulic fluid.</li> <li>2. Tighten mounting bolts.</li> <li>3. Replace motor coupling.</li> <li>4. Clean or replace filter.</li> </ol>

Lift stop short of full rise.	<ol style="list-style-type: none"> <li>1. Low on fluid.</li> <li>2. Suction line loose or damaged</li> </ol>	<ol style="list-style-type: none"> <li>1. Add oil.</li> <li>2. Replace suction line.</li> </ol>
Lift going up unlevel.	<ol style="list-style-type: none"> <li>1. Equalizer cables out of adjustment.</li> <li>2. Lift installed on unlevel floor.</li> </ol>	<ol style="list-style-type: none"> <li>1. Adjust equalizer cables to correct tension.</li> <li>2. Shim lift to level columns (Not to exceed 1/2").</li> </ol>
Anchors will not stay tight.	<ol style="list-style-type: none"> <li>1. Holes drilled oversize.</li> <li>2. Concrete floor thickness or holding strength not sufficient.</li> <li>3. Anchors not torqued correctly.</li> </ol>	<ol style="list-style-type: none"> <li>1. Relocate lift using a new bit to drill holes.</li> <li>2. Break out old concrete and repour new bay for lift.</li> <li>3. Torque bolts to correct spec.</li> </ol>
Locking latches do not engage.	<ol style="list-style-type: none"> <li>1. Tension spring broken. (7002A/9002/9002A)</li> </ol>	<ol style="list-style-type: none"> <li>2. Replace broken spring.</li> </ol>
Lift chatters on the way up.	<ol style="list-style-type: none"> <li>1. Air in system.</li> </ol>	<ol style="list-style-type: none"> <li>1. Bleed cylinders (7002A/9002/9002A).</li> </ol>
Slow lowering speed.	<ol style="list-style-type: none"> <li>1. Lowering valve (screen) plugged.</li> <li>2. Wrong weight of fluid.</li> <li>3. Pinched or collapsed line. (Restriction in line.)</li> <li>4. Foreign object in carriage column</li> </ol>	<ol style="list-style-type: none"> <li>1. Remove and clean lowering valve.</li> <li>2. Replace fluid with AW46 hydraulic fluid.</li> <li>3. Replace and/or clean lines.</li> <li>4. Remove foreign object.</li> </ol>
Lift will not lower.	<ol style="list-style-type: none"> <li>1. Latches engaging.</li> <li>2. Plugged cylinder orifice.</li> <li>3. Foreign object in carriage column</li> </ol>	<ol style="list-style-type: none"> <li>1. Check function of air cylinder.</li> <li>2. Call qualified service technician or consult factory.</li> <li>3. Remove foreign object.</li> </ol>
Broken Equalizer cable.	<ol style="list-style-type: none"> <li>1. Corrosion or fatigue.</li> </ol>	<ol style="list-style-type: none"> <li>1. Replace cable.</li> </ol>
When raising lift, adapter wants to move from pick up point.	<ol style="list-style-type: none"> <li>1. Column out of plumb</li> </ol>	<ol style="list-style-type: none"> <li>1. Plumb columns.</li> </ol>
Noticeable Defection of Arm or arm dragging on floor.	<ol style="list-style-type: none"> <li>1. Lift out of plumb.</li> <li>2. Unlevel floor.</li> <li>3. Worn arm pins.</li> <li>4. Worn arm or carriage holes.</li> <li>5. Worn carriage slide blocks.</li> <li>6. Bent arm (Overloaded)</li> </ol>	<ol style="list-style-type: none"> <li>1. Plumb columns.</li> <li>2. Replace floor of shim columns.</li> <li>3. Replace arm pins.</li> <li>4. Replace parts.</li> <li>5. Replace slide blocks.</li> <li>6. Replace arm. Also check damage to carriage.</li> </ol>

**⚠ CAUTION**

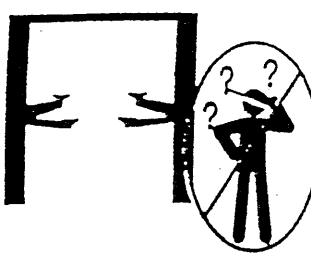

**Lift to be used by trained operator only.**

©

**⚠ CAUTION**



**Authorized personnel only in lift area.**

©

**⚠ WARNING**



**Clear area if vehicle is in danger of falling.**

©

**⚠ WARNING**

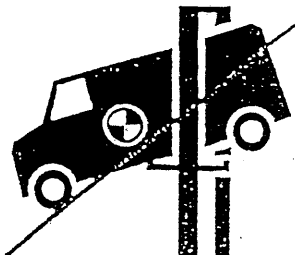

**Position vehicle with center of gravity midway between adapters.**

©

**⚠ CAUTION**

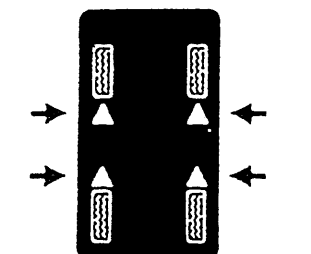

**Use vehicle manufacturer's lift points.**

©

**⚠ CAUTION**



**Always use safety stands when removing or installing heavy components.**

©

**⚠ WARNING**

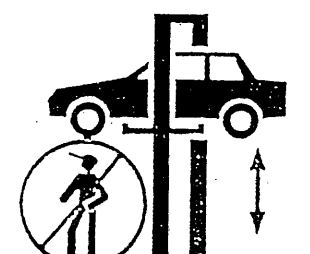

**Remain clear of lift when raising or lowering vehicle.**

©

**⚠ WARNING**



**Avoid excessive rocking of vehicle while on lift.**

©

**⚠ CAUTION**

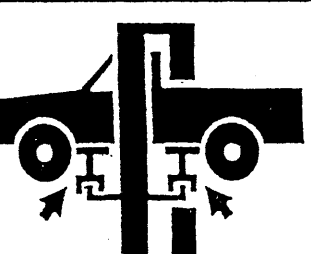

**Use height extenders when necessary to ensure good contact.**

©

**⚠ CAUTION**



**Auxiliary adapters may reduce load capacity.**

©

**⚠ WARNING**



**Do not override self-closing lift controls.**

©

**⚠ WARNING**



**Keep feet clear of lift while lowering.**

©

**SAFETY INSTRUCTIONS**

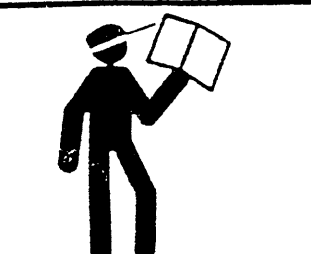

**Read operating and safety manuals before using lift.**

**SAFETY INSTRUCTIONS**

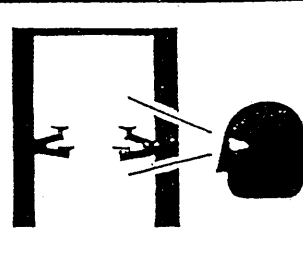

**Proper maintenance and inspection is necessary**

**SAFETY INSTRUCTIONS**

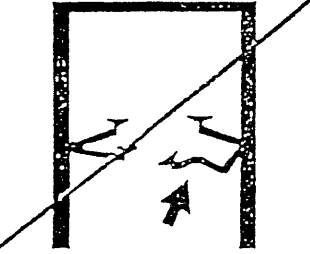

**Do not operate a damaged lift.**

The messages and pictographs shown are generic in nature and are meant to generally represent hazards common to all automotive lifts regardless of specific style.

Funding for the development and validation of these labels was provided by the Automotive Lift Institute, PO Box 33116 Indianapolis FL 32903

They are protected by copyright. Set of labels may be obtained from ALL or its member companies



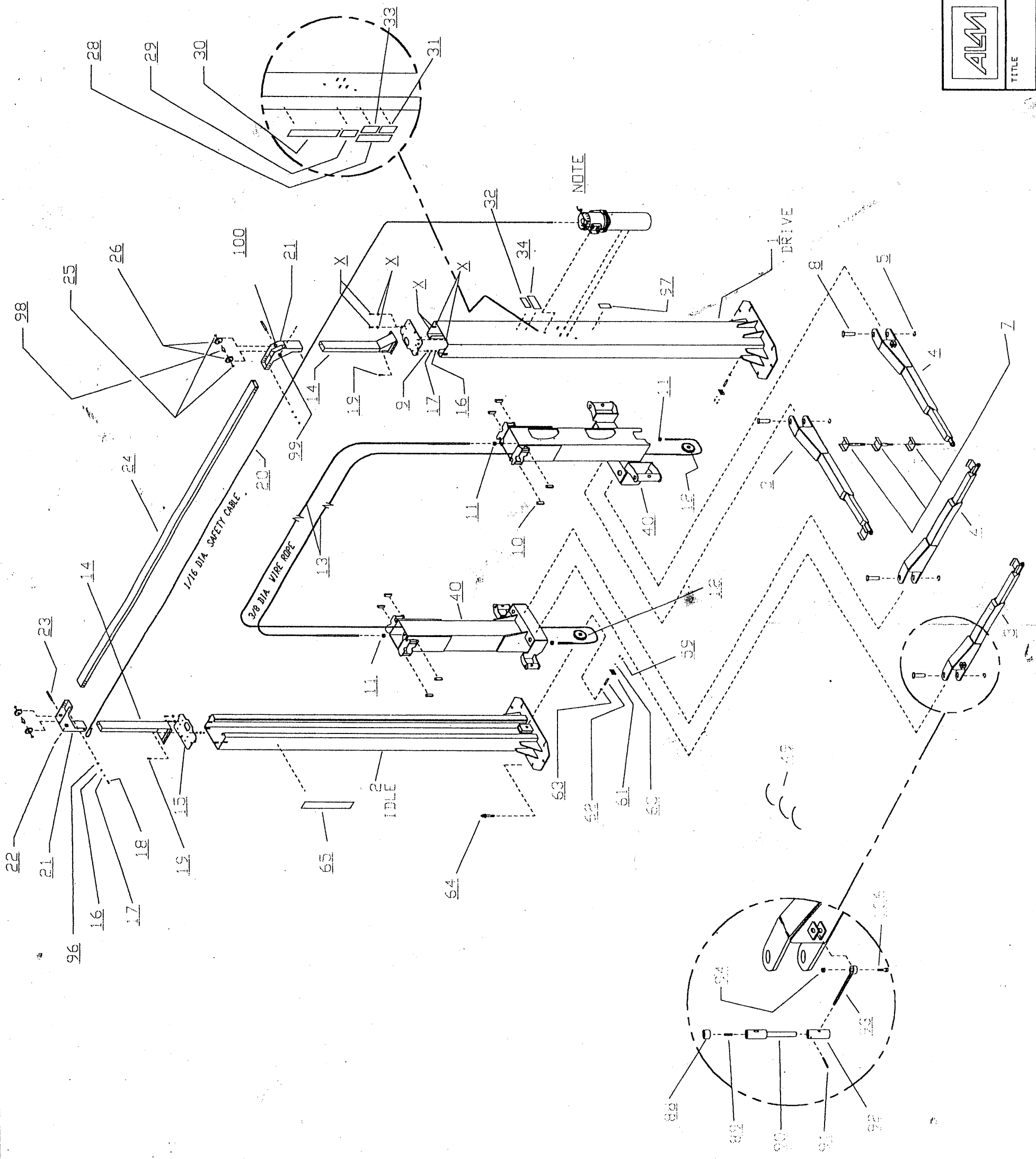

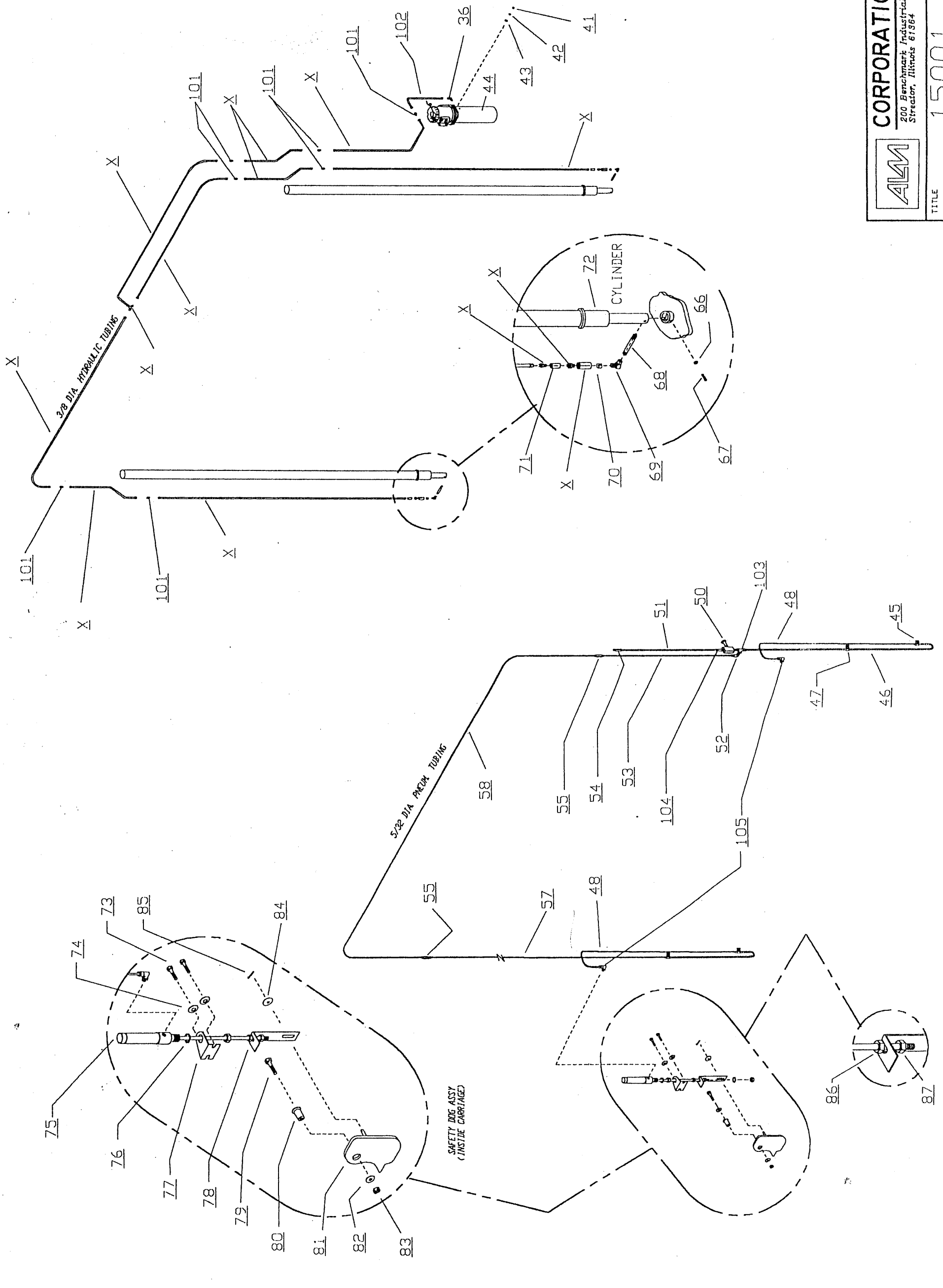

**CORPORATION**  
 200 Benchmark Industrial Dr.  
 Streator, Illinois 61864

TITLE	15001
DRAWING NO.	15001EXP. DWG
DATE	1/27/99
SHEET	2 of 2