

These installation instructions address the base and extruder mounting for the E3D Petsfang Direct Titan Mod and does not address wiring or filament spool mounting which will be different with each platform and clone hotend.

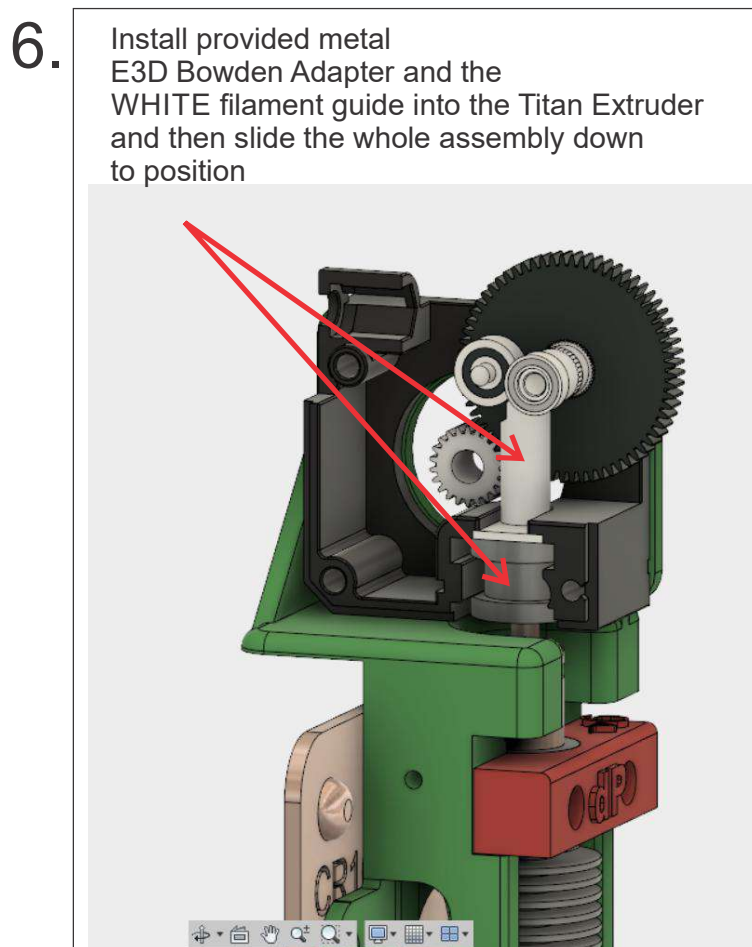
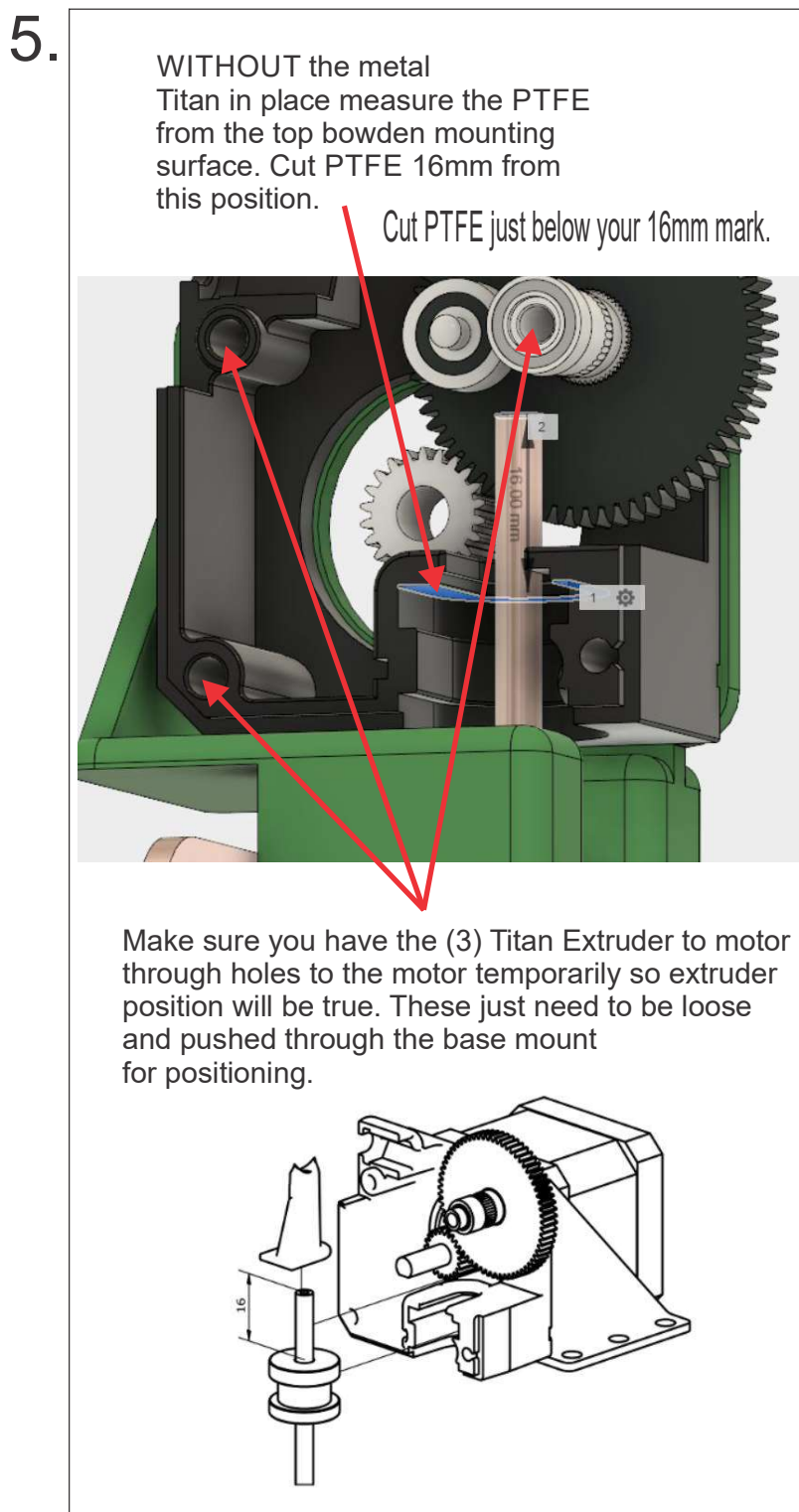
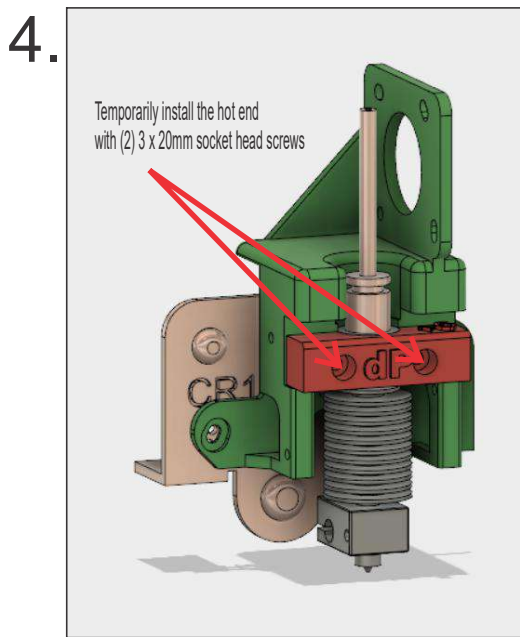
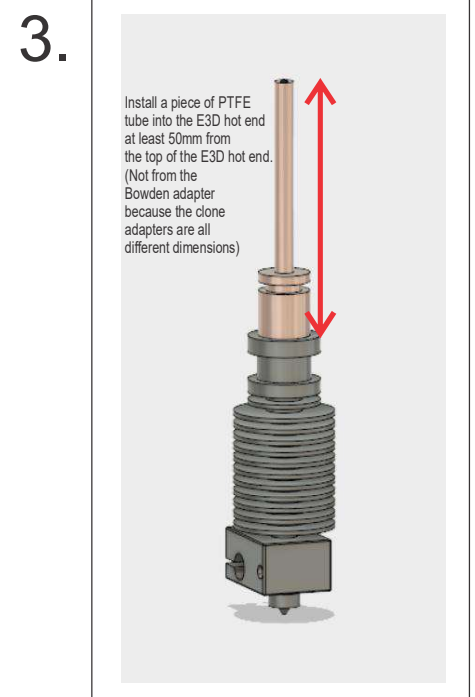
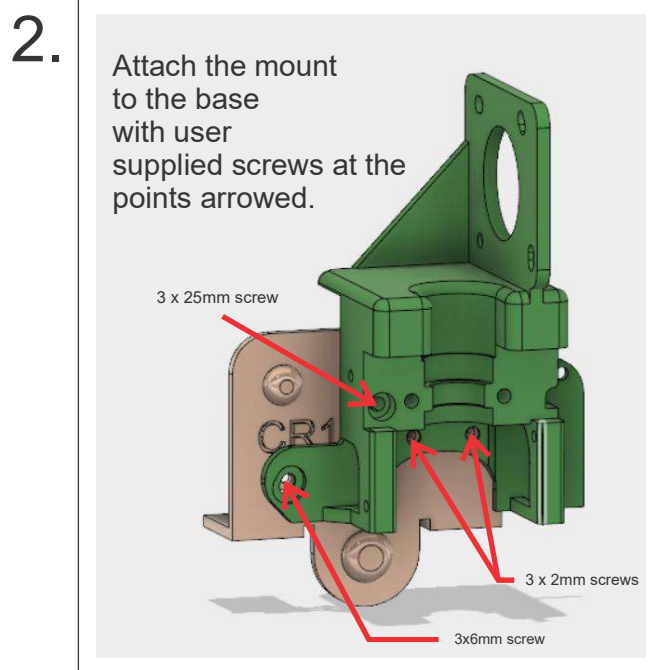
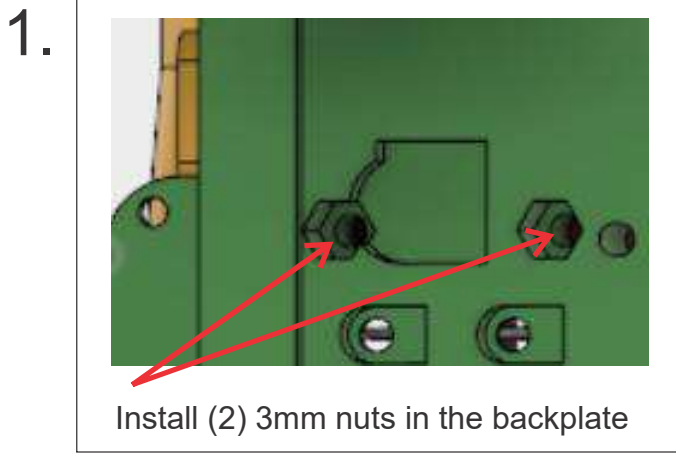

At this point you can finish the E3D Titan assembly at https://wiki.e3d-online.com/Titan_Assembly