



Prices effective January 6, 2020

Caper® Chairs

HermanMiller list prices shown are in USD. For HermanMiller Canadian prices, multiply the USD list price by a factor of 1.15---effective January 2020.

Introduction	page 2
Caper® Chairs	3
Multipurpose Chair	5
Multipurpose Stool	6
Stacking Stools	1
Stacking Chairs	10
Stacking Chair with Tablet Arm	14
Storage Baskets	16
Cart	18
Indices	19
By Name	19
By Number	21
Appendices	
20-Day or Less/Assigned Lead-Time Order Information	
Casters and Glides	
Fire Retardancy-Seating	
Proprietary Textiles Application Chart-Seating	
Proprietary Textile Colors-Seating	
For the latest materials information, refer to the Materials pages on HermanMiller.com.	

Introduction

A Note on the Organization of This Book

There are a few signals that will help you understand the organization of this book. Once you know them, you should be able to find your way around easily.

Like a newspaper, this book is formatted with columns of text and illustrations that run vertically.

Information wraps from one column to the next and continues for as many pages as it needs to.

Black bars are clues.

A black bar at the top of a page signals the start of information about a product.

This information is divided into two sections, each signaled by a black bar. Product Information includes a description, additional notes, and dimensional drawings. Specification Information, which always begins at the top of a column, includes a series of steps. Each step represents a decision you need to make in order to complete your product number. Steps must be followed sequentially. The number of pages needed to complete information on a product varies; some will be complete in one page; others may fill three or four pages. Just continue going through the steps until you run into the next product, signaled by the black bar at the top of the page.

Black tabs running along the outside edge of the page help you locate what section you are in or what section you want to go to. You can thumb forwards or backwards to find a section; tabs and text appear on both sides of the page.

The additional pages in the back of the book include the appendices and indices. They are signaled by a long black bar running along the outside edge of the page.

The index is presented two ways.

The first index is in alphabetical order by product name. It can be helpful if you are new to the products and numbering scheme or if you are looking for a type of product, such as work chair or round table.

The second index is by product number. It lists, in alphanumeric order, the base product number, typically a five-digit number.

General Information

This book is effective January 6, 2020, subject to change without notice. Products may be purchased from authorized Herman Miller dealers who will quote prices upon request. For more information about our products and services or to see a list of dealers, visit www.HermanMiller.com.

All prices are list prices. Additional services, such as planning services, design, storage, and installation, are not included and must be added to these prices when the additional services are requested.

Illustrations, specifications, and prices are based on the latest information at the time of publication. The right is reserved to make changes at any time without notice in prices, fabrics, finishes, materials, specifications, and models, and also to discontinue models and finishes.

Dimensions shown in the drawings are engineering drawing dimensions rounded up to the nearest $\frac{1}{8}$ ". Product is shipped set up or knocked down. Products that include "Shipped knocked down" in the description require some assembly. If this statement does not appear in the description, the product is shipped assembled.

Service problems are normally handled by a Herman Miller authorized dealer. Where this cannot be accomplished on a local level, service problems should be referred to the Customer Care Representative for your region, Herman Miller, Inc., Zeeland, Michigan 49464.

20-Day or Less/Assigned Lead-Time Shipments

All products and options in this price book not designated by an Assigned Program icon  will ship in **20 business days or less** after being acknowledged by Herman Miller.

Products and options designated by an  are on the assigned lead-time program and may ship in 20 days, less than 20 days, or more than 20 days from order acknowledgement.

Multipurpose Chair

Multipurpose Stools

Stacking Chairs

Cart

Multipurpose Chair

WC111
WC121



Product Information

Description

This multipurpose chair has a molded, flexible back that is perforated and contoured. It has a biomechanical tilt mechanism that synchronizes the movement of the chair's seat and back, pneumatic seat-height adjustment, and 5-star base with casters. The chair has 2 seat options: the molded seat is perforated and contoured; the Flexnet™ seat is suspension material. It is available with or without arms. All chairs meet CAL 133 requirements.

The multipurpose chair is breathable and distributes the user's weight evenly. Each chair is lightweight and mobile and has a cutout in the back for easy movement.

Notes

Chair is tested and warranted for use by persons 300 pounds and under. Caper® chairs are not recommended for outdoor use.

For information on casters, see Casters and Glides in Appendices.

Dimensions

Molded Seat

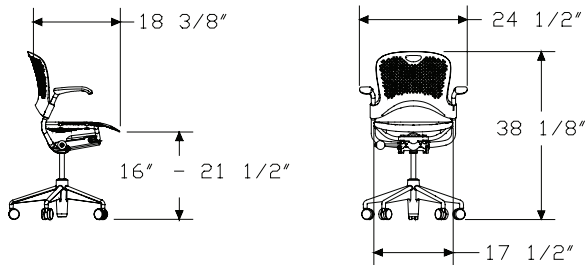

FLEXNET Seat

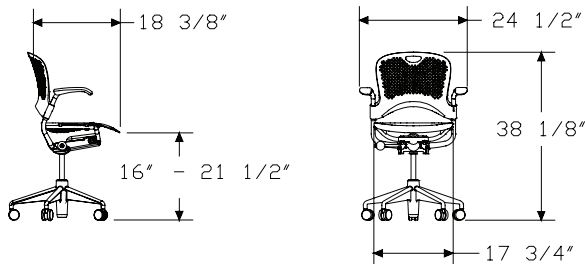

Specification Information

Step 1.

WC1

Step 2. Seat Style

11	molded seat	+\$700
21	flexnet™ seat	+\$860

Step 3. Arms

N	no arms	+\$0
P	fixed arms	+\$100

Step 4. Frame Finish

BK	black	+\$0
MS	metallic silver	+\$20

Step 5. Seat/Back Finish

3M	berry blue	+\$0
63	fog	+\$0
79	green apple	+\$0
98	studio white	+\$0
BK	black	+\$0
G1	graphite	+\$0
LMN	lemon	+\$0
RO	red	+\$0
TRQ	turquoise	+\$0
ZK	cappuccino	+\$0

Step 6. Casters

BB	2 1/2" hard caster, black yoke, carpet only	+\$0
C7	2 1/2" caster, black yoke, hard floors or carpet	+\$40
C9	2 1/2" braking caster, black yoke, hard floors or carpet	+\$50

Step 7. Arm Finish/Arm Cap Finish

63	fog	+\$0
BK	black	+\$0
SY	silver grey	+\$0

Step 8. Flexnet™ Material

For flexnet™ seat (21)

See application chart and textiles list for fabric usage and numbers.

First 2 digits of number indicate fabric line; remaining digit(s) indicate fabric color.

Price Category 1	+\$0
------------------	------

Caper® Multipurpose Stool

WC751
WC752



Caper® Multipurpose Stools

Product Information

Description
This multipurpose stool has a molded, flexible back that is perforated and contoured. It has a biomechanical tilt mechanism that synchronizes the movement of the stool's seat and back, pneumatic height adjustment and 5-star base. The stool has 2 seat options: the molded seat is perforated and contoured; the Flexnet™ seat is suspension material. It is available with or without arms. All stools meet CAL 133 requirements.

The stool is breathable and distributes the user's weight evenly.

Notes

Stool is tested and warranted for use by persons 300 pounds and under. Footrest available in trivalent chrome; column and ring support are black.

Caper® multipurpose stools are not recommended for outdoor use. For information on casters, see Casters and Glides in Appendices.

Dimensions

Molded Seat

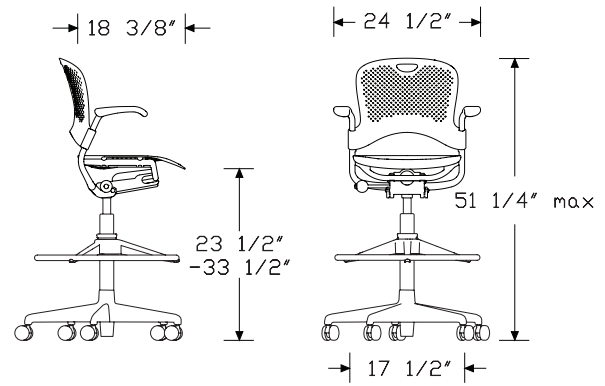

Flexnet Seat

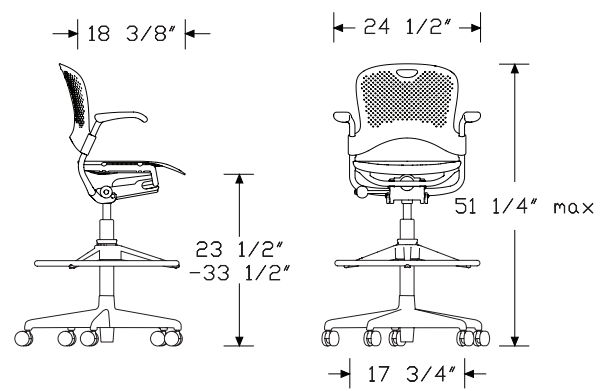

Specification Information

Step 1.

WC7

Step 2. Height Adjustment

5 5-star base, stool height range +\$963

Step 3. Seat Style

11 molded seat +\$0

21 flexnet™ seat +\$160

Step 4. Arms

N no arms +\$0

P fixed arms +\$100

Step 5. Frame Finish

BK black +\$0

MS metallic silver +\$20

Step 6. Seat/Back Finish

3M berry blue +\$0

63 fog +\$0

79 green apple +\$0

98 studio white +\$0

BK black +\$0

G1 graphite +\$0

LMN lemon +\$0

RO red +\$0

TRQ turquoise +\$0

ZK cappuccino +\$0

Step 7. Casters/Glides

BB 2½" hard caster, black yoke, carpet only +\$0

C7 2½" caster, black yoke, hard floors or carpet +\$40

C9 2½" braking caster, black yoke, hard floors or carpet +\$40

GF 2½" glide, hard floors or carpet +\$0

Step 8. Arm Finish/Arm Cap Finish

63 fog +\$0

BK black +\$0

SY silver grey +\$0

Step 9. Flexnet™ Material

For flexnet™ seat (21)

See application chart and textiles list for fabric usage and numbers.

First 2 digits of number indicate fabric line; remaining digit(s) indicate fabric color.

Price Category 1 +\$0

Caper® Stacking Stool

WC742
WC743

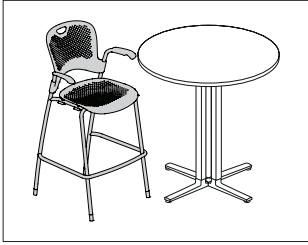

Caper® Multipurpose Stools

Product Information

Description

This stacking stool has a molded, flexible back that is perforated and contoured. The stool has a tubular steel frame and foot ring and comes in 24" (counter) and 30" (bar) heights. Available with or without arms. All chairs meet CAL 133 requirements.

All chairs meet CAL 133 requirements.

The stool has 2 seat options: the molded seat is perforated and contoured; the Flexnet™ seat is suspension material. Each stool is breathable and distributes the users weight evenly.

The stool is lightweight and mobile. The 24" stool weighs 13.8 pounds and the 30" stool weighs 14.9 pounds. All styles of this stool can be stacked up to 5 high on the floor. Each seat back has a cutout for easy movement.

Notes

Stool is tested and warranted for use by persons 300 pounds and under. Caper stacking stools are not recommended for outdoor use.

Glide color is predetermined based on arm finish/arm cap finish. For black (BK) and silver grey (SY), glides are black. For fog (63), glides are fog (63).

For information on casters and glides, see Casters and Glides in appendices.

Dimensions

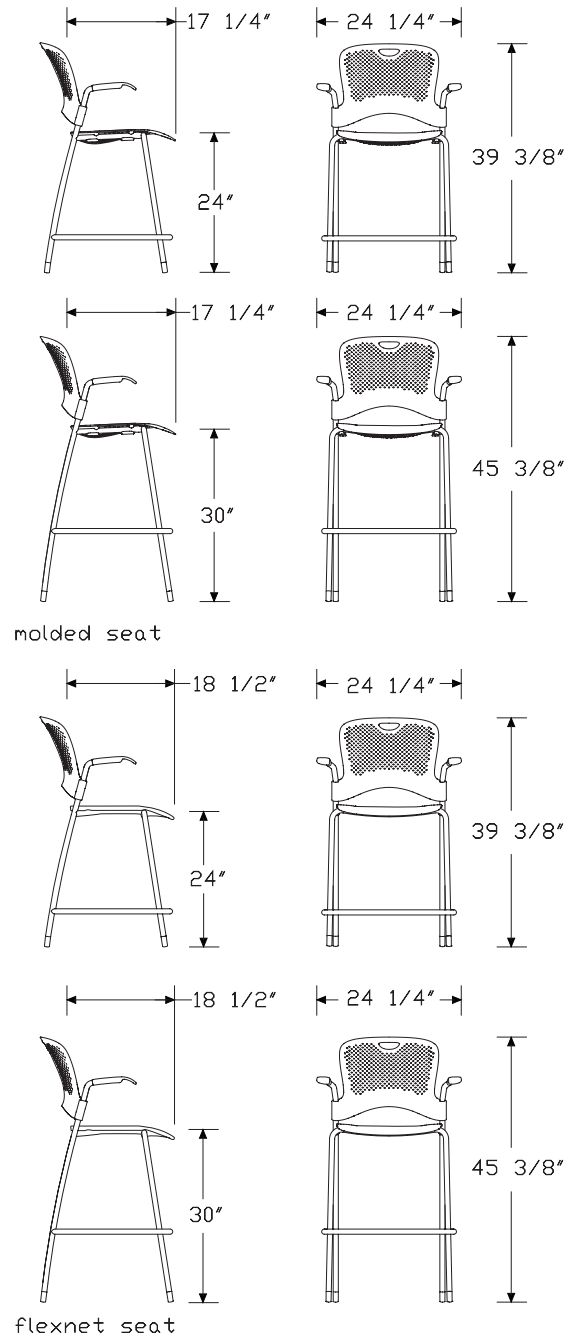

Specification Information

Step 1.

WC7

Step 2. Height Adjustment

424	4-leg base, counter height range	+\$490
430	4-leg base, bar height range	+\$490

Step 3. Seat Style

10	molded seat	+\$0
20	flexnet™ seat	+\$160

Step 4. Arms

N	no arms	+\$0
P	fixed arms	+\$100

Step 5. Frame Finish

BK	black	+\$0
MS	metallic silver	+\$20

Step 6. Seat/Back Finish

3M	berry blue	+\$0
63	fog	+\$0
79	green apple	+\$0
98	studio white	+\$0
BK	black	+\$0
G1	graphite	+\$0
LMN	lemon	+\$0
RO	red	+\$0
TRQ	turquoise	+\$0
ZK	cappuccino	+\$0

Step 7. Casters/Glides

Y7	acetal glide, carpet only	+\$0
YX	Floor Saver Glide® insert, hard floors only	+\$25

Step 8. Arm Finish/Arm Cap Finish

63	fog	+\$0
BK	black	+\$0
SY	silver grey	+\$0

Step 9. Flexnet™ Material

For flexnet™ seat (20)

See application chart and textiles list for fabric usage and numbers.

First 2 digits of number indicate fabric line; remaining digit(s) indicate fabric color.

Price Category 1	+\$0
------------------	------

Stacking Chair

WC410
WC420

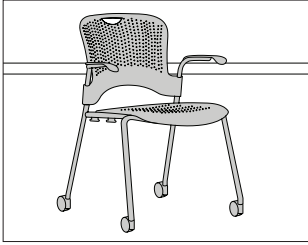

Caper® Stacking Chairs

Product Information

Description

This stacking chair has a tubular steel frame, a molded back that is perforated and contoured, and a 4-leg base with casters or glides. It has 2 seat options: the molded seat is perforated and contoured; the Flexnet™ seat is suspension material. Each chair is breathable and distributes the user's weight evenly. The chair is available with or without arms. All chairs meet CAL 133 requirements.

The chair is lightweight and mobile. The molded chair without arms weighs 9½ pounds and the Flexnet chair with arms weighs 11½ pounds. All styles of this chair can be stacked up to 6-chairs high on the floor and up to 15-chairs high on the Caper® cart. Each chair has a cutout in the back for easy movement.

Notes

Chair is tested and warranted for use by persons 300 pounds and under. Ganging stacking chairs (WC415 or WC425) can be stacked with armless stacking chairs (WC410N or WC420N) on the floor or on a Caper cart.

Caper chairs with installed storage basket will not stack. Order storage basket (WC6) separately.

Order optional Caper cart (WC904) separately.

Caper chairs are not recommended for outdoor use.

Glide color is predetermined based on arm finish/arm cap finish. For black (BK) and silver grey (SY), glides are black. For fog (63), glides are fog (63).

For information on casters and glides, see Casters and Glides in Appendices.

Dimensions

Molded Seat

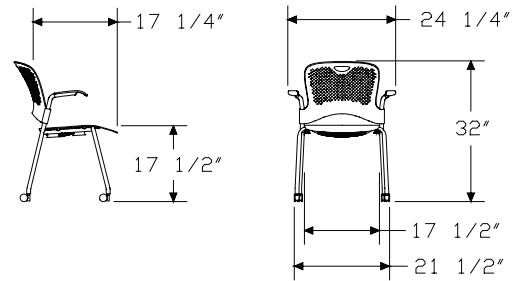

FLEXNET Seat

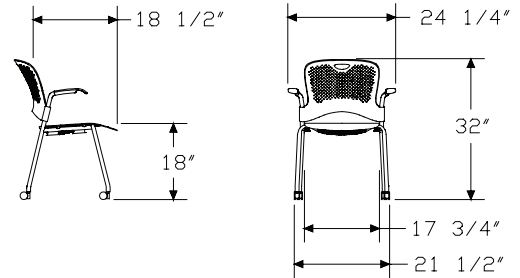

Stacking Chair *continued*

Specification Information

Step 1.

WC4

Step 2. Seat Style

10	molded seat	+\$254
20	flexnet™ seat	+\$414

Step 3. Arms

N	no arms	+\$0
P	fixed arms	+\$100

Step 4. Frame Finish

BK	black	+\$0
MS	metallic silver	+\$20

Step 5. Seat/Back Finish

3M	berry blue	+\$0
63	fog	+\$0
79	green apple	+\$0
98	studio white	+\$0
BK	black	+\$0
G1	graphite	+\$0
LMN	lemon	+\$0
RO	red	+\$0
TRQ	turquoise	+\$0
ZK	cappuccino	+\$0

Step 6. Casters/Glides

Y7	acetal glide, carpet only	+\$0
YX	Floor Saver Glide® insert, hard floors only	+\$25
U4	hard wheel caster, carpet only	+\$30
U5	soft wheel caster, carpet or hard floors	+\$30
DS	2" soft double wheel braking caster, hard floors	+\$30

Step 7. Arm Finish/Arm Cap Finish

63	fog	+\$0
BK	black	+\$0
SY	silver grey	+\$0

Step 8. Flexnet™ Material

For flexnet™ seat (20)

See application chart and textiles list for fabric usage and numbers.

First 2 digits of number indicate fabric line; remaining digit(s) indicate fabric color.

Price Category 1	+\$0
------------------	------

Ganging Stacking Chair

WC415
WC425

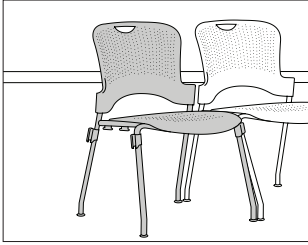

Product Information

Description

This ganging stacking chair has a tubular steel frame, a molded back that is perforated and contoured, and a 4-leg base with glides. It has 2 seat options: the molded seat is perforated and contoured; the Flexnet™ seat is suspension material. Each chair is breathable and distributes the user's weight evenly. The chair's ganging connectors are on the front and rear legs to ensure proper alignment. All chairs meet CAL 133 requirements.

The chair is lightweight and mobile and weighs 9½ pounds. It can be stacked up to 6-chairs high on the floor and up to 15-chairs high on the Caper® cart. Each chair has a cutout in the back for easy movement.

Notes

Chair is tested and warranted for use by persons 300 pounds and under. Ganging connector finish matches frame finish.

Ganging stacking chairs (WC415 or WC425) can be stacked with armless stacking chairs (WC410N or WC420N) on the floor or on a Caper cart.

Caper chairs with installed storage basket will not stack. Order storage basket (WC6) separately.

Order optional Caper cart (WC904) separately.

Caper chairs are not recommended for outdoor use.

Glide color is predetermined based on arm finish/arm cap finish. For black (BK) and silver grey (SY), glides are black. For fog (63), glides are fog (63).

For information on glides, see Casters and Glides in Appendices.

Caper® Stacking Chairs

Dimensions

Molded Seat

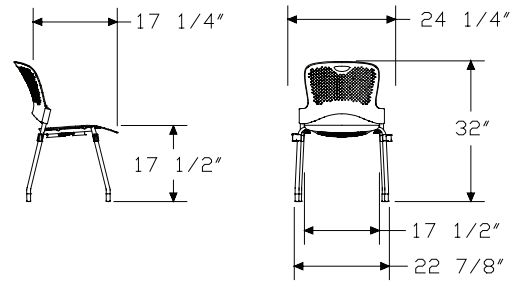

FLEXNET Seat

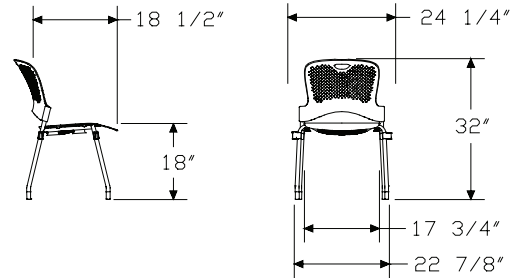

Ganging Stacking Chair *continued*

Specification Information

Step 1.

WC4

Step 2. Seat Style

15N	molded seat	+\$293
25N	flexnet™ seat	+\$453

Step 3. Frame Finish

BK	black	+\$0
MS	metallic silver	+\$20

Step 4. Seat/Back Finish

3M	berry blue	+\$0
63	fog	+\$0
79	green apple	+\$0
98	studio white	+\$0
BK	black	+\$0
G1	graphite	+\$0
LMN	lemon	+\$0
RO	red	+\$0
TRQ	turquoise	+\$0
ZK	cappuccino	+\$0

Step 5. Glide Option

Y7	acetal glide, carpet only	+\$0
YX	Floor Saver Glide® insert, hard floors only	+\$25

Step 6. Arm Cap Finish

63	fog	+\$0
BK	black	+\$0
SY	silver grey	+\$0

Step 7. Flexnet™ Material

For flexnet™ seat (25N)

See application chart and textiles list for fabric usage and numbers.

First 2 digits of number indicate fabric line; remaining digit(s) indicate fabric color.

Price Category 1	+\$0
------------------	------

Stacking Chair with Tablet Arm

WC510
WC520

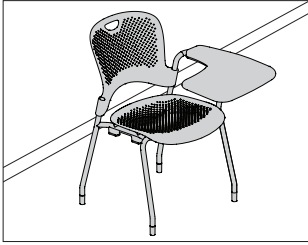

Caper® Stacking Chairs

Product Information

Description

This stacking chair with tablet arm has a tubular steel frame, a molded back that is perforated and contoured, and a 4-leg base with glides. It has 2 seat options: the molded seat is perforated and contoured; the Flexnet™ seat is suspension material. Each chair is breathable and distributes the user's weight evenly. The tablet arm can be specified on the left or right side. All chairs meet CAL 133 requirements.

The tablet is wood and flat, and available in a variety of laminate options. It is 17 7/8" W x 20 7/8" D. The tablet has a built-in dampener that prevents the tablet from falling down when extended.

This stacking chair with tablet can be stacked up to 3-chairs high on the floor or on the Caper® cart. Each chair has a cutout in the back for easy movement.

Tablet ships unassembled to the chair to prevent damage during shipping.

The tablet fully extends to 135° in the up position for ease of getting into and out of the chair.

Notes

Footprint of chair with tablet in down position is 32"H x 25"W x 31 1/2"D.

Footprint of chair with tablet fully extended in up position is 32"H x 35"W x 31 1/2"D.

Chair is tested and warranted for use by persons 300 pounds and under. Do not sit on or stack heavy objects on tablet arm. Product could tip and cause injury.

Chair with tablet cannot be ganged together.

Order optional Caper cart (WC904) separately.

Caper chairs are not recommended for outdoor use.

For information on glides, see Casters and Glides in appendices.

Dimensions

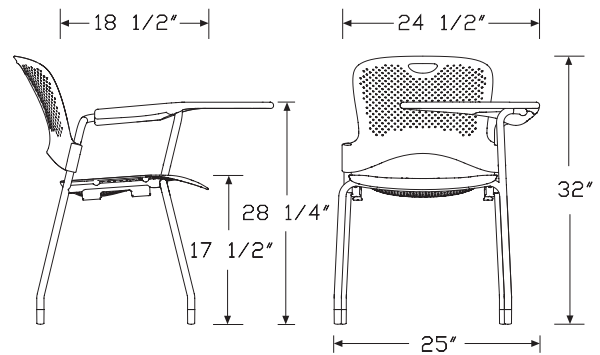

Molded Seat

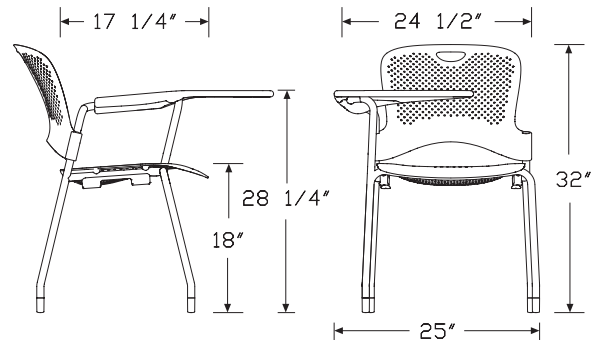

Flexnet Seat

Stacking Chair with Tablet Arm

continued

Specification Information

Step 1.

WC5

Step 2. Seat Style

10 molded seat +\$572
20 flexnet™ seat +\$732

Step 3. Tablet Arm Orientation

L tablet arm left +\$0
R tablet arm right +\$0

Step 4. Frame Finish

BK black +\$0
MS metallic silver +\$20

Step 5. Seat/Back Finish

3M berry blue +\$0
63 fog +\$0
79 green apple +\$0
98 studio white +\$0
BK black +\$0
G1 graphite +\$0
LMN lemon +\$0
RO red +\$0
TRQ turquoise +\$0
ZK cappuccino +\$0

Step 6. Glides

Y7 acetal glide, carpet only +\$0
YX Floor Saver Glide® insert, hard floors only +\$25

Step 7. Arm Finish/Arm Cap Finish

63 fog +\$0
BK black +\$0
SY silver grey +\$0

Step 8. Tablet Finish

76 light brown walnut +\$0
8Q folkstone grey +\$0
91 white +\$0
98 studio white +\$0
BU black umber +\$0
CL cool grey neutral +\$0
HF inner tone light +\$0
HM natural maple +\$0
HP light anigre +\$0

HT inner tone +\$0
HX aged cherry +\$0
HY walnut on cherry +\$0
LA light ash +\$0
LBA clear on ash +\$0
LBR phantom ecru +\$0
LBS phantom cocoa +\$0
LBU medium matte walnut +\$0
LBV warm grey teak +\$0
LBB oak on ash +\$0
LBC walnut on ash +\$0
LBD dark brown walnut +\$0
LBF neutral twill +\$0
LBG sarum twill +\$0
LBH earthen twill +\$0
LBJ graphite twill +\$0
LBM crisp linen +\$0
LBN classic linen +\$0
LBP casual linen +\$0
LBQ white twill +\$0
LT light tone +\$0
LU soft white +\$0
MT medium tone +\$0
WL sandstone +\$0
WN warm grey neutral +\$0

Step 9. Flexnet™ Material

For flexnet™ seat (20)
 See application chart and textiles list for fabric usage and numbers.
 First 2 digits of number indicate fabric line; remaining digit(s) indicate fabric color.

Price Category 1 +\$0

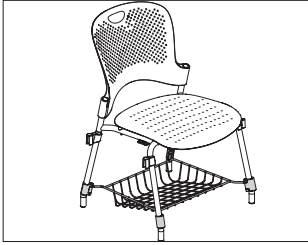

Caper® Stacking Chairs

Product Information

Description
 This storage basket installs in the field to all models of new or existing Caper® stacking chairs. Basket shape and wire mesh design prevent items from falling off or sliding back. Ships unassembled from the chair. Package contains 1 storage basket.

Notes

- Basket maximum weight capacity is 30 pounds.
- Specify basket finish to match chair frame finish.
- Caper chairs with installed storage basket will not stack.
- Order stacking chairs separately:
 - Stacking chair (WC410, WC420)
 - Ganging stacking chair (WC415N, WC425N)
 - Stacking chair with tablet arm (WC510, WC520)

Dimensions

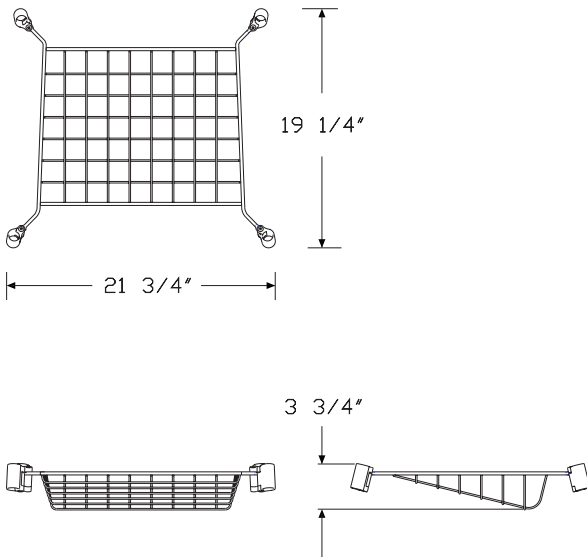

Specification Information

Step 1.

WC6 A

Step 2. Quantity per Box

01 one storage basket per box A +\$93

Step 3. Finish

BK black A +\$0

MS metallic silver A +\$0

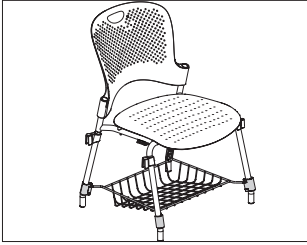

Product Information

Description

This storage basket installs in the field to all models of new or existing Caper® stacking chairs. Basket shape and wire mesh design prevent items from falling off or sliding back. Ships unassembled from the chair. Package contains 4 storage baskets.

Notes

- Basket maximum weight capacity is 30 pounds.
- Specify basket finish to match chair frame finish.
- Caper chairs with installed storage basket will not stack.
- Order stacking chairs separately:
 - Stacking chair (WC410, WC420)
 - Ganging stacking chair (WC415N, WC425N)
 - Stacking chair with tablet arm (WC510, WC520)

Dimensions

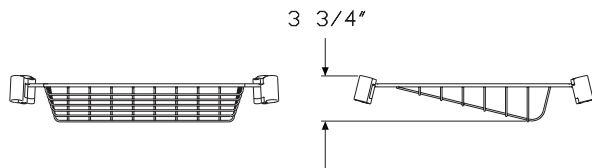
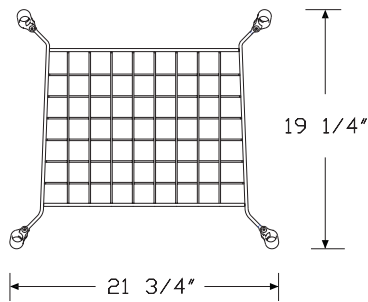

Specification Information

Step 1.

WC6 A

Step 2. Quantity per Box

04 four storage baskets per box A +\$359

Step 3. Finish

BK black A +\$0

MS metallic silver A +\$0

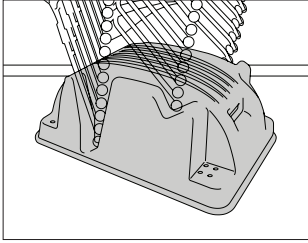

Product Information

Description

This cart stores and transports up to 15 Caper® stacking chairs or ganging stacking chairs, or up to 3 Caper stacking chairs with tablet arm. It has molded-in handles and 4"-diameter casters: 2 swivel and 2 rigid. The cart is single-piece-molded construction that ships fully assembled. Finish is black.

Notes

Ganging stacking chairs (WC415 or WC425) can be stacked with armless stacking chairs (WC410N or WC420N).
 Caper stacking chairs with tablet arm (WC510 or WC520) can be stacked only with other Caper stacking chairs with tablet arm.

Dimensions

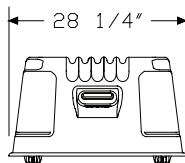
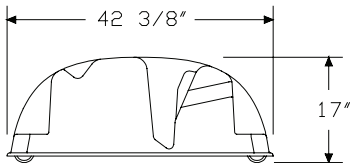

Specification Information

Step 1.

WC904

\$529

Index by Product Name

Caper® Chairs	
Caper® Cart	page(s) 18
Caper® Multipurpose Stool	6
Caper® Stacking Stool	8
Caper® Storage Basket	16
Caper® Storage Baskets	17
Ganging Stacking Chair	12
Multipurpose Chair	5
Stacking Chair	10
Stacking Chair with Tablet Arm	14

Index: Product Name



Index by Product Number

WC111 Multipurpose Chair	page(s) 5
WC121	
WC410 Stacking Chair	10
WC415 Ganging Stacking Chair	12
WC420 Stacking Chair	10
WC425 Ganging Stacking Chair	12
WC510 Stacking Chair with Tablet Arm	14
WC520	
WC601 Caper® Storage Basket	16
WC604 Caper® Storage Baskets	17
WC742 Caper® Stacking Stool	8
WC743	
WC751 Caper® Multipurpose Stool	6
WC752	
WC904 Caper® Cart	18



20-Day or Less/Assigned Lead-Time Order Information

20-Day or Less and Assigned Lead-Time Programs

20-day or less and assigned lead-time products are designed for established Herman Miller dealers with pre-approved credit.

Products are distributed from multiple manufacturing facilities across the United States. All products and options not designated by an Assigned Lead-Time icon **A** will ship in 20 business days or less after being acknowledged by Herman Miller. Products and options designated by an **A** are on the assigned lead-time program and will ship in 20 days, less than 20 days, or more than 20 days from order acknowledgement.

Ordering Procedure

Please place orders through Order Manager. If this is not available to you, place orders through mail or fax. Verbal purchase orders will not be accepted.

Order Entry fax number for Passage®, 5000 Series, and Meridian® Filing and Storage: (616) 846 9236.

Order Entry fax number for all other products:
(616) 654 3085.

For more information, contact your Customer Care representative at:
(866) 854 3048 EXT 3400.

Shipments and Delivery

Per Herman Miller Terms and Conditions.

Changes and Cancellation

Per Herman Miller Terms and Conditions.



Casters and Glides

▲	WARNING	▲
Depending on the floor surface, chair may unexpectedly roll away from user when entering or exiting the chair, possibly leading to unexpected injury. Please refer to descriptions of floor types when selecting casters.		

32 Caster

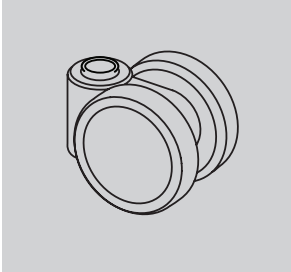

17/8-inch-diameter hard double-wheel caster; black nylon wheels and yoke; for use on carpet only

Applicable on:
Keyn Chairs
Sayl® Chairs

BB Caster

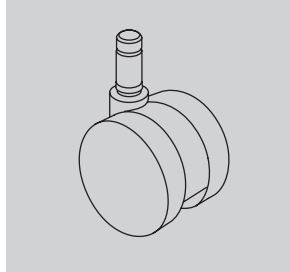

2 1/2-inch-diameter hard double-wheel caster; black nylon wheels and yoke; for use on carpet only

Applicable on:
New Aeron® Chairs
Caper® Chairs
Celle® Chairs
Embody® Chairs
Equa 2® Chairs
Ergon 3® Chairs
Lino™ Chairs Sayl Chairs
Mirra 2 Chairs Verus™ Chairs

BSC Caster

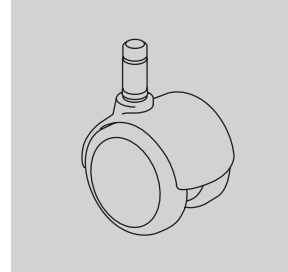

2-inch-diameter double-wheel caster; black nylon wheels and hood; soft polyurethane tread; for use on hard floors or carpet

Applicable on:
Eames® Aluminum Group
Eames Executive Chairs
Eames Soft Pad Group
Eames Task Chairs

C9 Caster

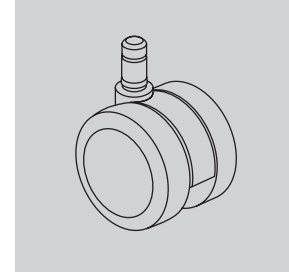

2 1/2-inch-diameter double-wheel caster; black nylon wheels and yoke; soft polyurethane tread; internal brake; for use on hard floors or carpet

Applicable on:
Caper Chairs
Celle Chairs
Embody Chairs
Equa 2 Chairs
Ergon 3 Chairs
Keyn Chairs Sayl Chairs
Lino Chairs Setu® Chairs
Mirra 2 Chairs Verus Chairs

49 Caster

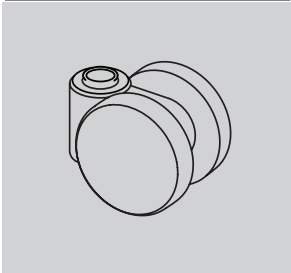

17/8-inch-diameter soft double-wheel caster; black nylon wheels and yoke; for use on hard floors or carpet

Applicable on:
Keyn Chairs
Sayl Chairs

BKS Caster

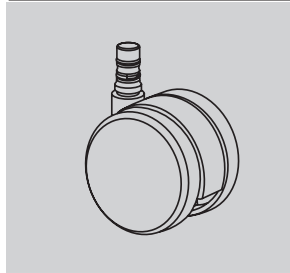

2 1/2-inch-diameter hard double-wheel caster; black yoke; quiet roll technology; for use on carpet only

Applicable on:
Cosm™ Chairs

C7 Caster

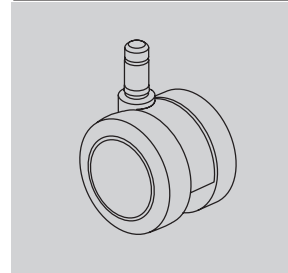

2 1/2-inch-diameter double-wheel caster; black nylon wheels and yoke; soft polyurethane tread; for use on hard floors or carpet

Applicable on:
New Aeron Chairs
Caper Chairs
Celle Chairs
Embody Chairs
Equa 2 Chairs
Ergon 3 Chairs
Lino Chairs
Mirra 2 Chairs
Sayl Chairs Verus Chairs

CA Caster



2-inch-diameter single-wheel caster; black rubber wheel with black yoke; for use on hard floors or carpet

Applicable on:
Co/Struc® System

Casters and Glides

continued

DC1 Caster

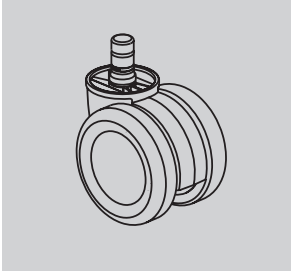

2 1/2-inch-diameter double-wheel braking caster; black nylon wheels and yoke; for use on hard floors or carpet; quiet roll technology

Applicable on:

New Aeron Chairs

H9 Caster

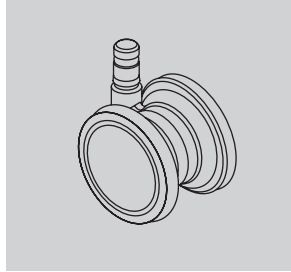

2 1/2-inch-diameter double-wheel caster; clear polycarbonate wheels; nylon yoke; soft polyurethane tread; for use on carpet only.

Applicable on:

Embody Chairs
Keyn Chairs

HW Caster

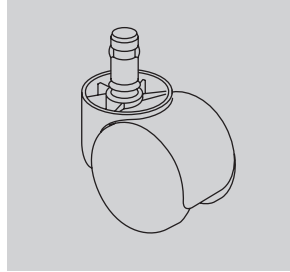

2-inch-diameter double-wheel caster; black nylon wheels and hood; for use on carpet only

Applicable on:

Limerick® Cart

O2 Caster

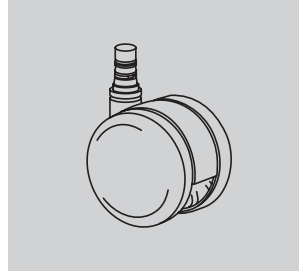

2 1/2-inch-diameter double-wheel caster; nylon wheels and yoke; soft polyurethane tread; quiet roll technology; for use on hard floors or carpet

Applicable on:

Cosm Chairs

DS Caster

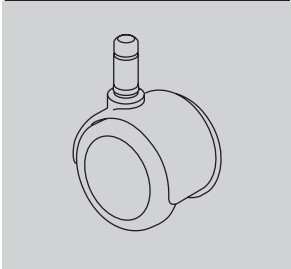

2-inch-diameter soft double-wheel braking caster; black nylon wheels and hood; for use on hard floors only

Applicable on:

Aside® Chairs
Caper Chairs

HCC Caster

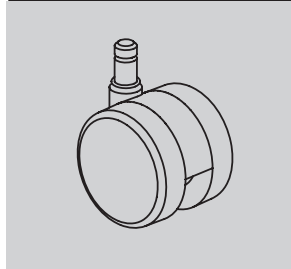

2 1/2-inch-diameter double-wheel low roll resistance caster; black yoke; for use on hard floors or carpet.

Applicable on:

Keyn Chairs
Setu Chairs

MD Caster

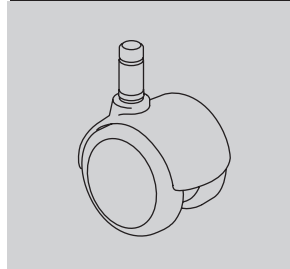

2-inch-diameter double-wheel caster; black nylon wheels with integral chrome hood; soft polyurethane tread; for use on hard floors or carpet

Applicable on:

Eames® Aluminum Group
Eames Executive Chairs
Eames Soft Pad Group
Eames Task Chairs

OC Caster

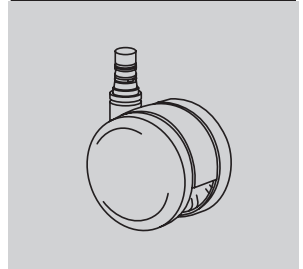

2 1/2-inch-diameter double-wheel medium roll-resistant caster; black nylon wheels and yoke; soft polyurethane tread; for use on hard floors or carpet; quiet roll technology

Applicable on:

Cosm Chairs
Keyn Chairs
Setu Chairs

Casters and Glides

continued

SC8 Caster

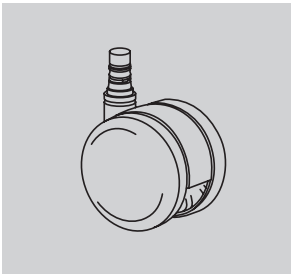

2 1/2-inch-diameter double-wheel caster; black nylon wheels and yoke; soft polyurethane tread; quiet roll technology; for use on hard floors or carpet

Applicable on:
Cosm Chairs
Mirra 2 Chairs

U4 Caster

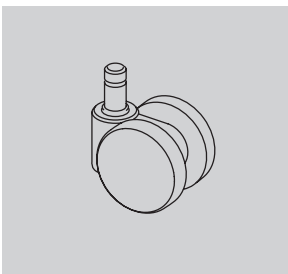

1 7/8-inch-diameter hard double-wheel caster; black nylon wheels and yoke; for use on carpet only

Applicable on:
Aside Chairs
Caper Chairs
Verus Chairs

UD Caster

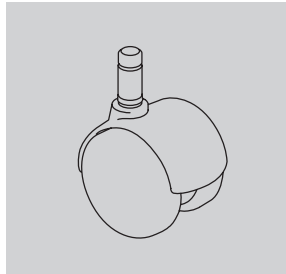

2-inch-diameter hard double-wheel caster; black nylon wheels with painted hood; for use on carpet only

Applicable on:
Eames® Aluminum Group
Eames Executive Chairs
Eames Soft Pad Group
Eames Task Chairs

16 Glide

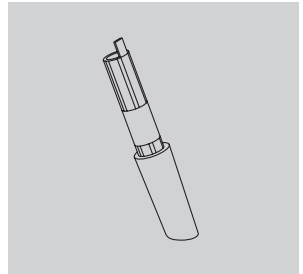

(Front glide shown)
2 1/8-inch-high glide; black or fog acetal; for use on carpet only

Applicable on:
Sayl Chairs

SW Caster

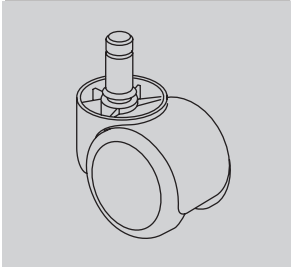

2-inch-diameter soft double-wheel caster; black nylon wheels and hood; for use on hard floors only

Applicable on:
Limerick Cart

U5 Caster

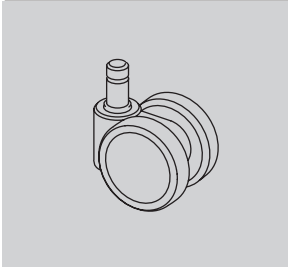

1 7/8-inch-diameter soft double-wheel caster; black nylon wheels and yoke; for use on hard floors or carpet

Applicable on:
Aside Chairs
Caper Chairs
Verus Chairs

VD Caster

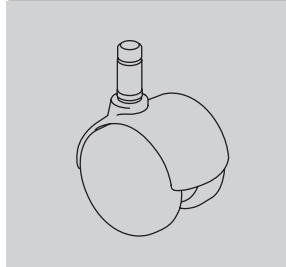

2-inch-diameter hard double-wheel caster; black nylon wheels with integral chrome hood; for use on carpet only

Applicable on:
Eames Aluminum Group
Eames Executive Chairs
Eames Soft Pad Group
Eames Task Chairs

69 Glide

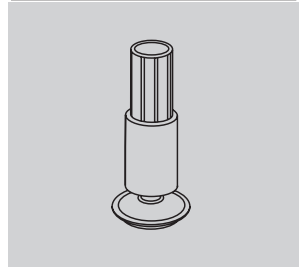

(Front glide shown)
2 1/8-inch-high glide; black glass-filled nylon stem; steel-plated swivel foot with Floor Saver Glide™ insert; for use on hard floors only

Applicable on:
Sayl Chairs

Casters and Glides

continued

Appendix: Casters and Glides

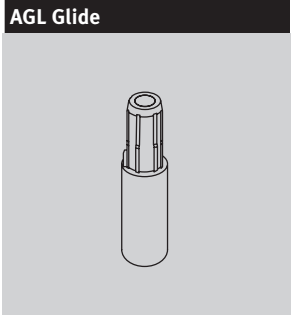

AGL Glide
 2¹/₄-inch-high glide; black or white nylon stem; for use on carpet only
 Applicable on:
 Keyn Chairs



G4 Glide
 1⁷/₈-inch-high glide; black acetal; for use on carpet only
 Applicable on:
 Verus Chairs



GF Glide
 2¹/₂-inch-high glide; black nylon; for use on hard floors or carpet
 Applicable on:
 New Aeron Chairs
 Caper Chairs
 Celle Chairs
 Cosm Chairs
 Equa 2 Chairs
 Ergon 3 Chairs
 Lino Chairs
 Mirra 2 Chairs
 Sayl Chairs
 Verus Chairs

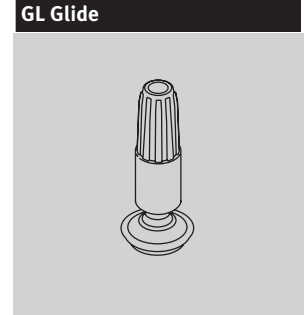

GL Glide
 1⁷/₈-inch-high glide; black nylon stem; steel-plated swivel foot with Floor Saver Glide™ insert; for use on hard floors only
 Applicable on:
 Verus chairs



FSG Glide
 2¹/₄-inch-high glide; black or white nylon stem; steel-plated swivel foot with Floor Saver Glide™ insert; for use on hard floors only
 Applicable on:
 Keyn Chairs



GD Glide
 1¹/₂-inch-diameter glide; 1/2 inch in height; black nylon; for use on hard floors or carpet
 Applicable on:
 Eames Aluminum Group
 Eames Executive Chairs
 Eames Soft Pad Group
 Eames Task Chairs



GG Glide
 1/2-inch-high ganging glide; clear polycarbonate; for use on hard floors or carpet
 Applicable on:
 Limerick Chairs

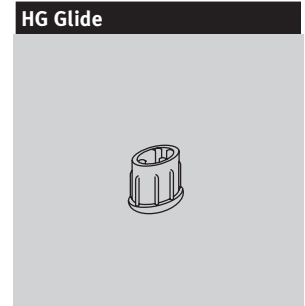

HG Glide
 1/2-inch-high glide; black nylon glide with stainless-steel insert; for use on hard floors or carpet
 Applicable on:
 Aside Chairs

Casters and Glides

continued

SB Glide



1/4-inch-high, 1-inch diameter glide; thermoplastic CAP material (G1 base has black glides; XT base has clear glides); for use on hard floors or carpet

Applicable on:

Equa 2 Chairs

SG Glide (for Limerick)

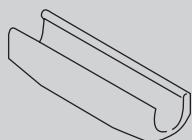

1/2-inch-high glide; clear polycarbonate; for use on hard floors or carpet

Applicable on:

Limerick Chairs

XS Glide

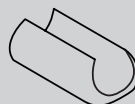

1/8-inch-high glide; polycarbonate in black, fog, clear, and studio white finishes; for use on hard floors or carpet

Applicable on:

Sayl Chairs

YX Glide

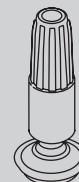

1 7/8-inch-high glide; black nylon stem; steel-plated swivel foot with Floor Saver Glide™ insert; for use on hard floors only

Applicable on:

Caper Chairs

SG Glide (for Aside)



1/2-inch-high glide; black nylon; for use on carpet only

Applicable on:

Aside Chairs

X8 Glide

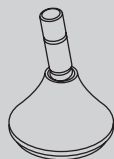

Glide; low profile; for use on hard floors or carpet

Applicable on:

Setu Chairs

Y7 Glide



1 7/8-inch-high glide; black acetal; for use on carpet only

Applicable on:

Caper Chairs



Fire Retardancy — Seating

Fire Retardancy

Fire-retardant chairs manufactured in approved fabrics (FR) meet California TB 133 requirements.

All foam and textiles on HermanMiller seating products comply with California TB 117-2013.

State of California
Bureau of Home Furnishings,
Technical Bulletin 133

State of California
Bureau of Home Furnishings,
Technical Bulletin 117-2013

8Z Pellicle		•
Ace		•
AireWeave™ 2		•
Aristo		•
Balance		•
Bento		•
Bingo		•
Crepe		•
Crossing		•
Cygnus™	FR	•
Dex		•
Dialogue		•
Duo		•
Epic		•
Fish Net		•
Flexnet™	FR	•
Gem		•
Hopsak		•
Intercept		•
InterWeave		•
Latitude™		•
Leather		•
Loom		•
Lyrus 2™		•
Marvel		•
Medley		•
Mercer		•
Moiré		•
Monologue		•
Noble		•
Pins and Needles		•
Plateau		•
Quilty		•
Rhythm		•
Rivet		•
Sequel		•
Spools		•
Stitches		•
Strata		•
String Plaid		•
Tailored		•
Twist		•
Well Suited		•
Whisper		•

• Fabric meets California TB 117-2013 code requirements.

FR To meet California TB 133 code requirements, fabrics must be applied to approved chairs identified with FR product numbers.



Proprietary Textiles Application Chart — Seating

• Available

[A] Assigned lead-time textile.

[N] Non-woven textile.

See following page for exception notes.

	Aeron® Chairs	Cosm™ Chairs	Mirra® 2 Chairs/Stools	Celle® Chairs/Stools	Embody® Chairs	Sayl® Work Chairs/Stools	Sayl Side Chairs	Setu® Chairs/Stools	Setu Lounge Chair/Ottoman	Verus™ Work Chairs/Stools Back	Verus Work Chairs/Stools Seat	Verus Side Chairs Back	Verus Side Chairs Seat	Verus Plus Chairs	Aside® Chairs	Caper® Chairs/Stools	Keyn Chair Group Back	Keyn Chair Group Seat	Lino™ Chairs Back	Lino Chairs Seat	Locale® Bench Cushion	Public Office Landscape® Back	Public Office Landscape Seat	Plex® Lounge Furniture	Swoop™ Lounge Seating - Fully Upholstered	Swoop Lounge Seating - Plywood	Valor™ Seating	Eames® Tandem Sling Seating	Cushion Tops	Workspaces	
Price Category 1																															
COM Customer's Own Material [A]			14			1	1			1	1	1	1	1	1			1		1	1				1	1	1		1	1	1
231__ 8Z Pellicle®	•																														
1A7__ AireWeave™ 2			•																												
8T__ Crossing			•					•	•						•						•				•	•				•	•
3DE__ Dex			14			•	•	•		•	•	•	•	•	•			•			•		•	19	•				•	•	
4RM__ Duo																			•												
6V__ Flexnet™																•															
95__ Gem			14					•	•						•						•				•	•				•	•
845__ Intercept		•																													
365__ Interweave 2										•		•																			
4W__ Lyris 2™								•	•																						
1MN__ Monologue			14			24	22	•	•	•	•	•	•				•	•			•	•	•	•	•	•	•	•	•	•	
3DK__ Stretch Knit [A]						21																									
235__ Tailored [A]			•		•	•	•	•		•	•	•	•	•	•		•	•			•			23					7	•	
1WS__ Whisper			14		24	•	•	•		•	•	•	•	•	•		•	•			•	•	•	•	•	•	•	•	•	•	
Price Category 2																															
3AR__ Aristo			14			•	•	•	•	•	•	•	•	•	•			•			•	•	•	•	•	•	•	•	•	•	•
92__ Crepe			•			•	•	•	•	•	•	•	•	•	•		•	•			•	•	•	•	•	•	•	•	•	•	•
3EP__ Epic			14			•	•	•		•	•	•	•	•	•		•	•			•	•	•	•	•	•	•	•	•	•	•
22Q__ Fish Net			•			•	•	•		•	•	•	•	•	•		•	•			•	•	•	•	•	•	•	•	•	•	•
1LM__ Loom			14			•	•			•	•	•	•	•			•	•			•	•	•	•	•	•	•	•	•	•	•
1MV__ Marvel [N]						21	22										•														
1HA__ Medley			15		•	•	22			•	•	•	•	•	•		•	•			•	•	•	•	•	•	•	•	•	•	•
30__ Rhythm			•	23	•	•				•	•	•	•	•	•		•	•			•	•	•	•	•	•	•	•	•	•	•
1RV__ Rivet			14		21	22				•	•	•	•	•	•		•	•			•	•	•	•	•	•	•	•	•	•	•
3SL__ Sequel [N] [A]			15		•	•	•	•	•	•	•	•	•	•	8		•	•			•	•	•	•	•	•	•	•	•	•	•
8R__ Twist			•		•	•	•	•	•	•	•	•	•	•	•		•	•			•	•	•	•	•	•	•	•	•	•	•
22T__ Well Suited														8											•	23					•
Price Category 3																															
3AC__ Ace [N]						21	•			•	•	•	•	•	8		•	•			•	•	•	•	19					•	
70__ Bento						•	•	•	•		•	•	•		8		•	•			•										•
4LN__ Landing																															•
8M__ Latitude™				23		•	•														•				•	•					
22V__ String Plaid			14		•	•				•	•	•	•	•	•		•	•			•	•	•	•	•	•	•	•	•	•	•
Price Category 4																															
1DL__ Dialogue																						•									
213__ Mercer			14		21	22				•	•	•	•	•			•	•			•		•		•	•					•
1A9__ Network																						•									
6S__ Quilty			14		•	•				•	•	•	•		•		•	•			•	•	•	•	•	•	•	•	•	•	•
22P__ Strata					•	•	•			•	•	•	•	•	•		•	•			•	•	•	•	•	•	•	•	•	•	•
3SY__ Sync			•	•	•	•	•	•	•	•	•	•	•	•	•		•	•			•	•	•	•	•	•	•	•	•	•	•

continued on next page

Proprietary Textiles Application Chart — Seating continued

• Available

[A] Assigned lead-time textile.

[N] Non-woven textile.

See below for exception notes.

	Aeron® Chairs	Cosm™ Chairs	Mirra® 2 Chairs/Stools	Celle® Chairs/Stools	Embody® Chairs	Sayl® Work Chairs/Stools	Sayl Side Chairs	Setu® Chairs/Stools	Setu Lounge Chair/Ottoman	Verus™ Work Chairs/Stools Back	Verus Work Chairs/Stools Seat	Verus Side Chairs Back	Verus Side Chairs Seat	Verus Plus Chairs	Aside® Chairs	Caper® Chairs/Stools	Keyn Chair Group Back	Keyn Chair Group Seat	Lino™ Chairs Back	Lino Chairs Seat	Locale® Bench Cushion	Public Office Landscape® Back	Public Office Landscape Seat	Plex® Lounge Furniture	Swoop™ Lounge Seating - Fully Upholstered	Swoop Lounge Seating - Plywood	Valor™ Seating	Eames® Tandem Sling Seating	Cushion Tops	Workspaces			
Price Category 5																																	
14A__ Hopsak			14		•	•	•	•	•	•	•	•	•	•	•	•	•	•	•	•	•	•	•	•	•	•	•	•	•	•	•	•	•
22N__ Noble (22H__)	[A]		14		•	25	•			•	•	•	•	•	8		•	•		•	•		•	•	•	•	•			•		•	
3SU__ Summit [N]			15		•	•				•	•	•	•	•						•	•		•	•	•	•					•		
Price Category 6																																	
35__ Balance					•																												
Price Category 7																																	
COL Customers Own Leather	[A]	1	14												8																		1
Price Category 8																																	
No fabrics available at this time																																	
Price Category 9																																	
21__ Leather [N]		23	14												8					•							•					•	

Application Note: Herman Miller cannot guarantee material/pattern alignment in adjacent products. For example, a fabric's pattern may not align from one pedestal cushion top to the next, or from one chair to another.

- 1 Refer to price book appendices and Omni for COM/COL information.
- 7 Available on 1" Cushion Tops only.
- 8 Only available on the Aside nonupholstered outer back option (PB).
- 14 Available on Celle UC (upholstered seat) and Celle UF (upholstered seat) Chairs.
- 15 Available only on Celle HC (upholstered seat with protective edge) and Celle HF (upholstered seat) Chairs.
- 19 Available on Plex seat only.
- 20 Available in select colors. Refer to "Proprietary Textile Colors - Seating" for color offering.
- 21 Not available on Sayl upholstered back work chairs.
- 22 Not available on Sayl side chairs with upholstered backs.
- 23 Available in select colors. Refer to "Proprietary Textile Colors-Seating" for color offering.
- 24 Not available on Sayl upholstered High-Back Work Chairs.
- 25 Not available on Sayl side chairs with upholstered backs. Available in select colors. Refer to "Proprietary Textile Colors-Seating" for color offering.

Proprietary Textile Colors — Seating

Price Category 1

Customer's Own Material
See Order Information in
Appendices.
Assigned lead-time textile. A

8Z Pellicle®
For New Aeron® Chairs
56% elastomeric
44% polyester
23101 Mineral
23102 Carbon
23103 Graphite

AireWeave™ 2
For Mirra® 2 Chairs
67% elastomeric
33% antimony-free polyester
1A701 Alpine
1A702 Slate Grey
1A703 Graphite
1A704 Lime Green
1A705 Cappuccino
1A706 Urban Orange
1A707 Dark Turquoise
1A708 Twilight

Crossing
54" wide
86% antimony-free polyester
14% polyester
8T03 Wicker
8T04 Porcelain
8T05 Warm Grey
8T06 Sepia
8T07 Pumpkin
8T08 Copper
8T09 Cranberry
8T10 Tomato
8T11 Mulberry
8T12 Plum
8T13 Green Apple
8T14 Loden
8T15 Spruce
8T16 Periwinkle
8T17 Cerulean
8T18 Indigo
8T19 Shale
8T20 Brownstone
8T21 Bark
8T22 Tin
8T23 Graphite
8T24 Black

Dex
54" wide
50% recycled polyester
50% polyester
3DE01 Frost
3DE02 Silver Pine
3DE03 Stone
3DE04 Shale
3DE05 Charcoal

Duo
For Lino™ Chairs
52% polyester
48% elastomeric
4RM01 Mineral
4RM02 Poppy
4RM03 Green Leaf
4RM04 Jade
4RM05 Shadow
4RM06 Graphite

Flexnet™
For Caper® Chairs
69% elastomeric
31% polyester
6V01 Black
6V02 Silver Grey

Gem
54" wide
100% antimony-free polyester
9502 Tangerine
9503 Red
9507 Twilight
9508 Bayou
9510 Berry Blue
9511 Aqua Green
9512 Green Apple
9514 Black
9515 Slate Grey
9516 Fog

Intercept
For Cosm™ Chairs
60% elastomeric
40% polyester
84501 Graphite
84502 Carbon
84503 Mineral
84504 Nightfall
84505 Glacier
84506 Canyon

Interweave 2
For Verus™ Chairs
65% elastomeric
35% polyester
36501 Iceberg
36502 Poppy
36503 Beachglass
36504 Blue Grotto
36505 Slate
36506 Shale

Lyris 2™
For Setu® Chairs
74% elastomeric
26% polyester
4W21 Alpine
4W22 Mango
4W23 Chartreuse
4W25 Berry Blue
4W26 Slate Grey
4W28 Chino
4W29 Rattan
4W30 Java
4W31 Graphite

Monologue
54" wide
56% recycled polyester
44% polyester
1MN01 Linen
1MN02 Alabaster
1MN03 Truffle
1MN04 Folkstone
1MN05 Silver Pine
1MN06 Slate
1MN07 Seed
1MN08 Yellow Oxide
1MN09 Persimmon
1MN10 Tundra
1MN11 Meadow
1MN12 Blue Sky
1MN13 Blue Spruce
1MN14 Deep Sea

Stretch Knit
Assigned lead-time textile. A
Available only on Sayl®
Suspension Back Work Chairs
97% polyester, 3% spandex
3DK01 Fog
3DK02 Slate Grey
3DK03 Java
3DK04 Black
3DK05 Red
3DK06 Green Apple
3DK07 Berry Blue

*Price category 1 continued on
next page*

Proprietary Textile Colors — Seating

continued

Price Category 1

continued

Tailored

Assigned lead-time textile. A

54" wide
56% polyester
44% recycled polyester

23501	Studio White *
23502	Sugar *
23503	Tomato
23504	Orchid
23505	Boysenberry
23506	Chive
23507	Bluegrass
23508	Cobalt
23509	Cadet
23510	Fog
23511	Graphite
23512	Black
23513	Coffee

* Colors not available on Plex™ Lounge Furniture.

Whisper

54" wide
73% recycled polyester
27% polyester

1WS01	Sand Dollar
1WS02	Pebble
1WS03	Silver Birch
1WS04	Iceberg
1WS05	Silver Pine
1WS06	Carbon
1WS07	Cumin
1WS08	Adobe
1WS09	Strawberry
1WS10	Blush
1WS11	Eggplant
1WS12	Willow
1WS13	Sea Grass
1WS14	Pool
1WS15	Blueberry

Price Category 2

Aristo

54" wide
88% recycled polyester
12% polyester
Acrylic backing

3AR01	Forest Moss
3AR02	Light Brindle
3AR03	Mink
3AR04	Copper
3AR05	Adobe
3AR06	Cherry
3AR07	Lilac
3AR08	Green Apple
3AR09	Surf
3AR10	Waterfall
3AR11	Cadet
3AR12	Tin
3AR13	Pewter
3AR14	Grey Brindle
3AR15	Grey Black

Crepe

54" wide
100% recycled polyester

9201	Licorice
9203	Smoke
9207	Cherry
9209	Claret
9212	Raisin
9218	Aquamarine
9223	Cadet
9241	Beachglass
9243	Midnight
9244	Artichoke
9248	Warm White
9249	Stone
9250	Earth
9251	Fog
9252	Slate Grey
9253	Yellow Dark
9254	Coral
9255	Blush Grey
9256	Wild Berry
9257	Clover
9258	Caribbean
9259	Cerulean

Crepe continued

9260	Brownstone
9261	Shale
9262	Graphite
9263	Tomato
9264	Green Apple

Epic

54" wide
56% recycled polyester
44% polyester
Acrylic backing

3EP01	Alabaster
3EP02	Smoke
3EP03	Falcon
3EP04	Citrus Spring
3EP05	Copper
3EP06	Urban Orange
3EP07	Poppy
3EP08	Wild Plum
3EP09	Sugar Plum
3EP10	Clover
3EP11	Loden
3EP12	Everglade
3EP13	Mist
3EP14	Peacock
3EP15	Cadet
3EP16	Indigo
3EP17	Spring Wood
3EP18	Grey Brindle
3EP19	Seed
3EP20	Carbon Dark

Fish Net

55" wide
100% recycled polyester

22Q01	Oyster
22Q02	Stone
22Q03	Citrus
22Q04	Curry
22Q05	Chipotle
22Q06	Cherry
22Q07	Fuschia
22Q08	Claret
22Q09	Purple
22Q10	Clover
22Q11	Pesto
22Q12	Peacock
22Q13	Lagoon
22Q14	Twilight
22Q15	Bluestone
22Q16	Storm
22Q17	Black
22Q18	Cocoa

Loom

54" wide
100% polyester

1LM01	Linen *
1LM02	Brown Sugar and Spice
1LM03	Brick and Mortar
1LM04	Salt and Pepper
1LM05	Black
1LM06	Lemongrass
1LM07	Poppy
1LM08	Wild Berry
1LM09	Loden
1LM10	Jade
1LM11	Deep Sea

* Color not available on Valor™ Seating

Price category 2 continued on next page

Proprietary Textile Colors — Seating

continued

Price Category 2

continued

Marvel	
54" wide	
100% pvc-free polyurethane	
1MV01	Summer White
1MV02	Sand Dollar
1MV03	Espresso
1MV04	Folkstone Grey
1MV05	Graphite
1MV06	Onyx
1MV07	Polar Blue
1MV08	Blush Grey
1MV09	Woodrose
1MV10	Citrus
1MV11	Adobe
1MV12	Red
1MV13	Kiwi Green
1MV14	Pine
1MV15	Teal Green
1MV16	Twilight

Medley	
54" wide	
100% polyester	
1HA01	Stone
1HA02	Trail
1HA03	Charcoal
1HA04	Cinder
1HA05	Citrus
1HA06	Papaya
1HA07	Chutney
1HA08	Tundra
1HA09	Feather Grey
1HA10	Chartreuse
1HA11	Loden
1HA12	Peacock
1HA13	Bayou
1HA14	Blue Grotto
1HA15	Blueberry
1HA22	Khaki
1HA23	Pewter
1HA24	Yellow Oxide
1HA25	Vintage Rose
1HA26	Raspberry
1HA27	Acai Berry

Rhythm	
54" wide	
100% polyester	
3001	Kiwi Green *
3002	Green Apple
3003	Peacock
3004	Bayou *
3005	Berry Blue
3006	Iris
3007	Twilight
3008	Pumpkin *
3009	Poppy *
3010	Molasses
3011	Mulberry
3012	Khaki *
3013	Mink
3014	Black
3015	Charcoal

* Colors not available on Embody® Chair.

Rivet	
54" wide	
100% recycled polyester	
1RV01	Twig
1RV02	Deep Clay
1RV03	Woodrose
1RV04	Otter
1RV05	Hemlock
1RV06	Olive
1RV07	Lagoon
1RV08	Deep Sea
1RV09	Charcoal
1RV10	Grey Brindle

Sequel	
Assigned lead-time textile. A	
54" wide	
100% vinyl	
100% polyester knit backing	
Resilience® finish	
3SL01	White
3SL02	Pebble
3SL03	Mushroom
3SL04	Stone
3SL05	Chestnut
3SL06	Rattan
3SL07	Black Cherry
3SL08	Tundra
3SL09	Seal
3SL10	Blue Fog
3SL11	Folkstone
3SL12	Shale
3SL13	Slate Grey
3SL14	Charcoal
3SL15	Carbon Dark
3SL28	Navy

Twist	
54" wide	
80% antimony-free polyester	
13% recycled polyester	
7% polyester	
8R05	Wicker
8R10	Poppy
8R14	Tin
8R15	Shale
8R16	Graphite
8R17	Birch
8R18	Sepia
8R22	Blueberry
8R23	Green Apple
8R26	Gunmetal
8R27	Cinder
8R28	Citrus
8R29	Pekoe
8R30	Tangerine
8R31	Red Plum
8R32	Wisteria
8R33	Forest
8R34	Jade Dark
8R35	Waterfall
8R36	Midnight Blue
8R37	Carbon Dark

Well Suited	
55" wide	
79% polyester	
21% recycled polyester	
22T01	Oyster *
22T02	Raffia *
22T03	Peppermint *
22T08	Cool Grey *
22T16	Jade
22T17	Peacock
22T18	Blueberry

* Colors not available on Swoop™ Plywood Lounge Seating.

Proprietary Textile Colors — Seating

continued

Price Category 3

Ace	
54" wide	
100% polyurethane	
Polyester knit backing	
Stain resistant finish	
3AC01	Summer White
3AC02	White Ash
3AC03	Rye
3AC04	Metal
3AC05	Clay
3AC06	Chestnut
3AC07	Citrus
3AC08	Camelback
3AC09	Chipotle
3AC10	Claret
3AC11	Slate Purple
3AC12	Artichoke
3AC13	Sepia Dark
3AC14	Aloe
3AC15	Flint
3AC16	Blue Sky
3AC17	Oceanside
3AC18	Midnight
3AC19	Spring Wood
3AC20	Frost
3AC21	Lead
3AC22	Black

Bento	
54" wide	
100% antimony-free polyester	
7001	Frost
7002	Linen
7003	Khaki
7004	Truffle
7005	Grey Black
7006	Pumpkin
7007	Cranberry
7008	Everglade
7009	Cobalt

Landing	
For Eames® Tandem Sling Seating	
54" wide	
100% TPE	
Polyester knit backing	
4LN01	Black

Latitude™	
61" wide	
100% polyester	
8M01	Graphite
8M02	Shadow
8M10	Alpine
8M17	Black
8M21	Slate Grey
8M22	Lime Green
8M23	French Press
8M24	Urban Orange
8M25	Dark Turquoise
8M26	Twilight

Latitude	
Colors for Mirra 2 Chairs	
100% polyester	
8M10	Alpine
8M17	Black
8M21	Slate Grey
8M22	Lime Green
8M23	French Press
8M24	Urban Orange
8M25	Dark Turquoise
8M26	Twilight

String Plaid	
54" wide	
100% recycled polyester	
22V01	Warm White on Khaki
22V02	Mint on Yellow Green
22V03	Mist on Blue Grey
22V04	Sky Blue on Red
22V05	Lime on Magenta
22V06	Bright Green on Green
22V07	Aqua Blue on Cerulean
22V08	Ivory on Black

Price Category 4

Dialogue	
For Public Office Landscape®	
Sectional Back/Social Chair Back	
knit to size	
100% polyester	
1DL01	Light Brindle
1DL02	Dark Brindle

Mercer	
54" wide	
50% solution dyed recycled nylon	
50% solution dyed nylon	
BLOCKaide	
21301	Stone
21303	Cayenne
21305	Pesto
21306	Teal Blue
21307	Ultramarine
21310	Charcoal

Network	
For Public Office Landscape®	
Sectional Back/Social Chair Back	
knit to size	
100% polyester	
1A901	Warm White
1A902	Fog
1A903	Red
1A904	Wildberry
1A905	Green Apple
1A906	Twilight
1A907	Graphite

Price category 4 continued on next page

Proprietary Textile Colors — Seating

continued

Price Category 4

continued

Quilty	
56" wide	
100% antimony-free polyester	
GreenShield	
6S03	Khaki
6S04	Straw
6S07	Brick
6S10	Mink
6S11	Green Apple
6S13	Indigo
6S14	Zinc
6S15	Slate
6S16	Beachwood
6S17	Paprika
6S18	Plum
6S19	Juniper
6S20	Grey Black

Strata	
54" wide	
50% solution dyed recycled nylon	
50% solution dyed nylon	
BLOCKaide	
22P04	Pesto
22P05	Peacock
22P06	Blue Jay
22P07	Blueberry
22P09	Mango
22P10	Paprika
22P12	Wheat
22P13	Brownstone
22P14	Bayou

Sync	
55" wide	
100% polyester	
3SY01	Pine Cone
3SY02	Citron
3SY03	Canyon
3SY04	Truffle
3SY05	Wild Berry
3SY06	Everglade
3SY07	Glacier
3SY08	Nightfall
3SY09	Dark Mineral
3SY10	Slate Grey
3SY11	Dark Carbon
3SY12	Black

Price Category 5

Hopsak	
56" wide	
100% recycled polyester	
14A20	Black
14A22	Raw Umber Dark
14A26	Grey Blue Dark
14A30	Sepia Dark
14A38	Emerald Dark
14A39	Yellow Dark
14A40	Orange
14A41	Sienna
14A42	Olive Green Dark
14A43	Crimson
14A44	Crimson Dark Dark
14A45	Violet Dark
14A46	Pink Dark Dark
14A47	Ultramarine Dark
14A48	Cobalt Blue
14A49	Terra Cotta
14A50	Ochre Dark

Noble	
Assigned lead-time textile. <input type="checkbox"/>	
54" wide	
100% wool	
22N07	Cadet *
22N12	Blue Grey Mix *
22H15	Heathered Black **
22H16	Heathered Grey **
22H17	Heathered Twilight **
22H18	Heathered Rye Grass **
22N23	Lagoon Mix *

* Colors not available on Sayl® Side Chairs.

** Colors not available on Sayl Side Chairs Back.

Summit	
54" wide	
100% silicone	
Polyester knit backing	
3SU01	Bright White
3SU02	Oyster
3SU03	Metal
3SU04	Khaki
3SU05	Taupe
3SU06	Java
3SU07	Black
3SU08	Cherry
3SU09	Beachglass
3SU10	Midnight

Proprietary Textile Colors — Seating

continued

Appendix: Proprietary Textile Colors — Seating

Price Category 6

Balance	
For Embody® chairs	
100% polyester	
3512	Carbon
3513	Black

Price Category 7

Customer's Own Leather
See Order Information in Appendices. Assigned lead-time textile. A

Price Category 8

No fabrics available at this time.

Price Category 9

Leather	
approx. 50 sq. ft. per hide	
100% leather	
2101	Ivory
2109	Black *
2110	Smoke
2111	Graphite
2112	Khaki
2113	Rattan
2114	Truffle
2115	Alpine
2116	Haze
2117	Sable Grey
2118	Dark Mineral **
2119	Dark Carbon ***
2120	Cranberry
2121	Deep Sea

* Armpad color available on Aeron® Chair, Graphite.

** Armpad color available on Aeron Chair, Mineral.

*** Armpad color available on Aeron Chair, Carbon.

For more information about our products and services or to see a list of dealers, please visit us at HermanMiller.com or call (800) 851 1196.

© 2020 Herman Miller, Inc., Zeeland, Michigan

Distribution Rights

Working together since 1956, Herman Miller and Vitra are the authentic sources of designs by Charles and Ray Eames, Alexander Girard, and George Nelson. All the designs shown in this book are protected by law. Herman Miller has obtained all rights to make and sell these designs. Also, Herman Miller holds exclusive worldwide manufacturing and distribution rights for these products with the following exceptions:

Charles and Ray Eames, George Nelson, and Alexander Girard—Worldwide distribution rights for furniture in all areas except Europe and the Middle East. For those areas, please contact Vitra.

Isamu Noguchi—Worldwide distribution rights for the Noguchi Rudder Table. Distribution rights for the Noguchi Table in North America and Central America only. For all other areas, please contact Vitra.

Magis—Exclusive distribution rights in the US and Canada. For all other areas, please contact Magis.

Mattiazzi—Exclusive distribution rights in the US and Canada. For all other areas, please contact Mattiazzi.

® **HermanMiller**, ●, 3D Intelligent, AO, Action Office, Aeron, ArcSpan, Aside, Avall, Avive, Bubble Lamps, Canvas Office Landscape, Capex, Celle, Co/Struc, Daisyone, Distil, Eames, Eco-Dematerialized, Embody, Envelop, Equa 2, Ergon 3, Ethospace, Exclave, Fine-Tune, FlexFront, Flo, Formcoat, Formwork, Ground Cloth, Herman Miller for the Home, Herman Miller for Healthcare, Intersect, Kinemat, Lapjack, Layout Studio, Lifework, Limerick, Live Unframed, Living Office, Locale, Maharam, Meridian, Mirra, Motia, Passage, Pellicle, Perspectives, Plex, PostureFit, Public Office Landscape, Resolve, Rodney, Sayl, Setu, Thrive, Tu, Wishbone, and Y-Tower are among the registered trademarks of Herman Miller, Inc., and its owned subsidiaries.

™ 8Z Pellicle, About Face, AireWeave, Albert, Backfit, Bubbletack, Burdick Group, Butterfly Back, Celeste, Cellular Suspension, Clam, Commend, Compass, Connect, Cosm, Cubert, DOT, Duracare, Durawrap, Eames Soft Pad, EnhancedAccess, Everywhere, Flex-Edge, Flute, Harmonic, Headway, Herman Miller Select, Hopsak 2, Intent, Iota, Jaw, Keyless Entry, Keyn Chair Group by Herman Miller, Latitude, Lino, Locale, Logic Mini, Logic Power Access Solutions, Live Platform, Loop, Lyris, Lyris 2, Made-to-Measure Storage, Metaform Portfolio, Mora, Multiscrim, Nelson, Nevi, Overlay, Pari, Pixelated Support, PostureFit SL, Prospect, Q, Renew, Sense, Soft Pad, Stackable, Stackable Storage, Striad, Swoop, Tone, TriFlex, Twist, Ubi, Valor, Verus, Vista and Wireframe are among the trademarks of Herman Miller, Inc., and its owned subsidiaries.

SM Herman Miller Options is among the service marks of Herman Miller, Inc.

AAP™ is a trademark of Extron Electronics.

Alexander Girard® is a registered trademark of The Alexander Girard Estate.

Chemsurf® is a registered trademark of Wilsonart International.

Corian® is a registered trademark of E. I. du Pont de Nemours and Company Corporation.

Crypton® is a registered trademark of Crypton, Inc.

DACRON® is a registered trademark of INVISTA S.a r.l.

Danzer® is a registered trademark of Danzer Holding AG.

Decora® is a registered trademark of Leviton Manufacturing Co., Inc.

Edelman® Leather is a registered trademark of Edelman Leather, Inc.

Extron® is a registered trademark of RGB Systems, Inc.

FENIX NTM® is a registered trademark of Arpa Industriale S.p.A.

FLEXNET™ is a trademark of Milliken & Company.

Floor Saver Glide® is a registered trademark of Carpin Manufacturing, Inc.

Geiger® is a registered trademark, and Bumper™, Saiba™, and Ward Bennett™ are trademarks, of Geiger International.

Goetz™ is a trademark of Mark W. Goetz.

Hang-It-All® is a registered trademark of Lucia Eames Demetrios, d.b.a. Eames Office.

Holophane® is a registered trademark of Holophane.

Ingeo™ is a trademark of Cargill Dow LLC.

iPad® is a registered trademark of Apple, Inc.

Leviton® is a registered trademark of Leviton Manufacturing Co., Inc.

LifeSize® is a registered trademark of LifeSize Communications, Inc.

Magis®, Bombo®, and Me Too® are registered trademarks of Magis S.p.A.

Microsoft® and Natural® Keyboard are registered trademarks of Microsoft Corporation.

Noguchi® and the Noguchi table configuration (trade dress) are registered trademarks, and Rudder Table™ is a trademark, of The Isamu Noguchi Foundation and Garden Museum.

Place Textiles® is a registered trademark of Place Textiles.

SuperSeat™ is a trademark of Dahti Seating, a division of ITW.