

TORQ-PIN

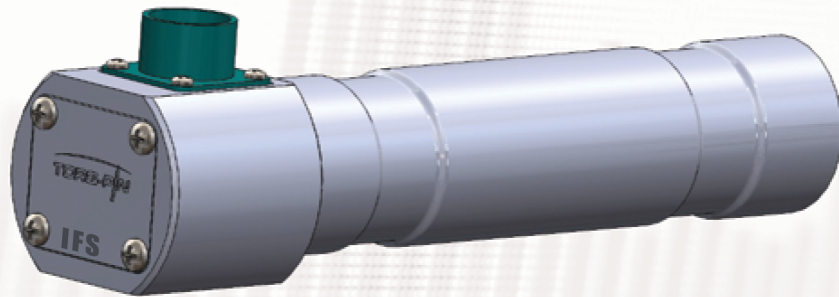

98%

**Accurate Torque Measurement
and Data Logging System for
Helical Pile Installers**



INNOVATIVE

FOUNDATION SOLUTIONS LTD.

www.ifsequip.com

99% Accurate Torque Readings

Innovative Foundation Solutions' Torq Pin systems are in use worldwide and have an excellent reputation for accuracy, durability and after sales support. Utilizing our patented strain gauge technology, it delivers over 99% accurate torque readings. Data is sent over a wired or wireless connection (a robust 2.4 GHz RF FHSS signal to the handheld display/datalogger)

The Torq Pin measures and records torque, inclination and offers the user the opportunity to manually enter pile depth as well as other job specific information.

This torque monitoring and data logging device is intended to replace the OEM pin on the top of the drive head casing. IFS offers pins from stock for all major manufacturers' drive heads, and can provide custom pins upon request. The Torq Pin is designed for rigid mount applications. If mounting to any type of telescoping (or other non-rigid) booms, the IFS Torq Hub is a better choice for the application.

Hardwired or Wireless Options

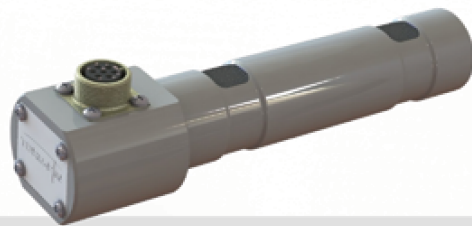

Wireless signal is 2.4 GHz FHSS RF. Outdoor range – up to 2.5 miles (4 km) Frequency Hopping Spread Spectrum technology allows clear communication across up to 79 frequencies

Hardwired/ cable connections are all rugged, overmolded, sheathed cable assemblies with Amphenol Mil-Spec threaded connections.



Electronics fully potted, gasketed and sealed to protect from environment. Calibration data is stored on internal, non-volatile memory.

Torq Pins are available from stock for all major OEM drive head models. Other sizes available on request.

Circuit boards, firmware and software all designed for specific standards for the application. Fully potted, sealed, gasketed and cushioned to ensure maximum protection and long life.



7" Windows OS LCD touchscreen in a rugged ABS casing. Designed to IP67 ingress protection.

Circuit boards, firmware and software all designed for specific standards for the application. Fully potted, sealed, gasketed and cushioned to ensure maximum protection and long life.

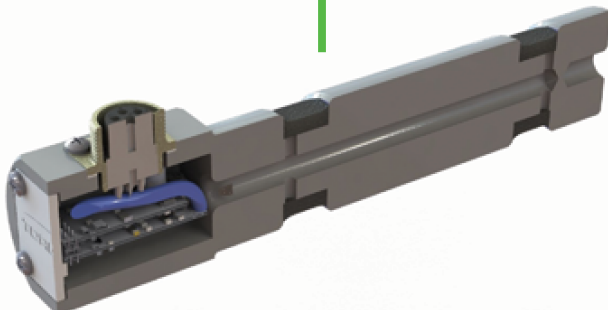

Improved Reporting



IFS is pleased to introduce our vastly improved reporting capabilities.

- ⇒ Reports are exportable directly from the display, either via email using a smartphone with its' hotspot enabled, or through the onboard USB port connected to a flash drive.
- ⇒ Reports are exported as both bare data (.dat file – open with Excel), and as a PDF line chart as shown below. One cover page for the job and a page for each individual pile is generated.
- ⇒ Additionally, the PDF line chart will show depth as it is entered during the job. This will give the engineer a view of depth vs. torque on each pile. An optional hand held trigger is available which allows the operator (or his helper) to depress it when the pile/ anchor reaches a marked depth, allowing a more accurate (and more continuous) representation of torque vs. time"

User Customizable Logo & Company Name

Simple to review look for torque data exceeding user preset threshold

Job	DATE	Target Torque	Actual Torque	Max Torque
113-000-2018	11/13/2018	31,800 ft-lbs	31,800 ft-lbs	31,800 ft-lbs

File Name	Page
Target Torque	25,000 (ft-lbs)
Maximum Torque	26,374 (ft-lbs)
Target Depth	10.0 (ft)
Maximum Depth	1.6 (ft)
Latitude	0
Longitude	0
Date	11/13/2018
Notes	

Report auto-generated by Geotek Torque Pin software on 11-13-2018 Page 1

Report auto-generated by Geotek Torque Pin software on 11-13-2018 Page 2

Smartphone Apps

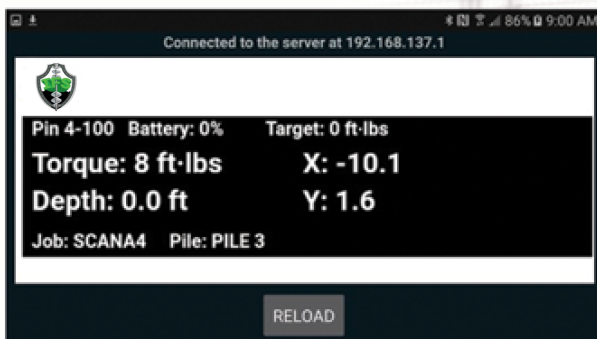

IFS is now offering a free smartphone app for both iOS (Apple) and Android (Samsung, etc) users.

- ⇒ Available for FREE download from either the Apple App Store or Google Play.
- ⇒ Allows a user to remotely monitor torque and inclination data for piles/ anchors as they are installed via a WiFi connection between their smartphone and our display.

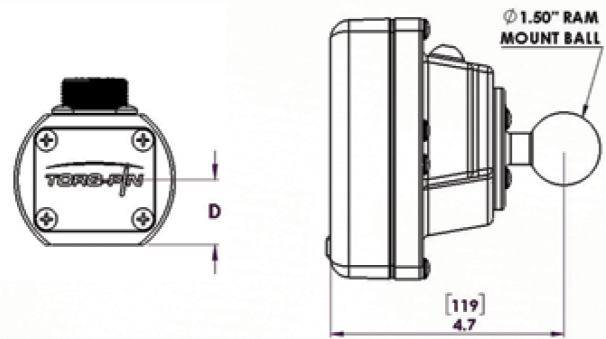
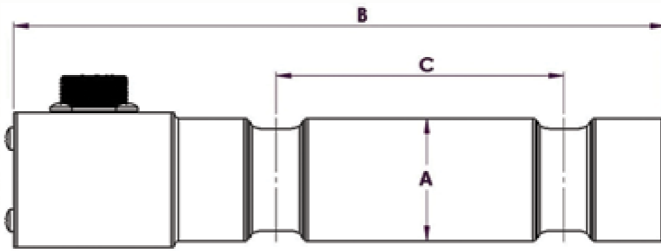

Rated Output (R.O):	2 mV/V nominal
Nonlinearity:	0.1% of R.O.
Hysteresis:	0.1% of R.O.
Nonrepeatability:	0.05% of R.O.
Zero Balance:	1.0% of R.O.
Compensated Temp. Range:	60° to 160° F
Safe Temp. Range:	-65° to 200° F
Temp. Effect on Output:	0.005% of Load/° F
Temp. Effect on Zero:	0.005% of R.O./° F
Terminal Resistance:	350 ohms nominal
Excitation Voltage:	5 VDC

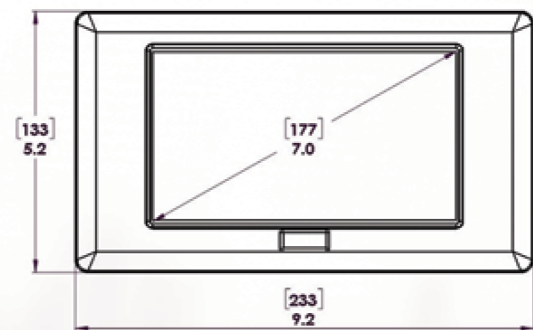

MFG/MODEL	A-DIAMETER	B-OAL	C-SPACING	D-ANTI-ROTATION	CTS P/N
PENGO CLASS 1	1.772" [45mm]	9.63" [244mm]	4.25" [108mm]	0.969" [24.6mm]	TPPECL1
PENGO CLASS 2	2.953" [75mm]	12.63" [321mm]	6.25" [159mm]	1.554" [39.5mm]	TPPECL2
PENGO CLASS 3	3.976" [101mm]	28.5" [724mm]	11.5" [292mm]	2.00" [50.8mm]	TPPECL3
PENGO CLASS 4	4.500" [114.3mm]	33.38" [848mm]	18.5" [470mm]	2.275" [57.8mm]	TPPECL4
DIGGA PDI 9-30	1.772" [45mm]	9.63" [244mm]	4.25" [108mm]	0.969" [24.6mm]	TPDIGPD
DIGGS SD	2.953" [75mm]	13.68" [348mm]	5.35" [136mm]	1.554" [39.5mm]	TPDIGSD
DIGGA MD/ UD	3.812" [97mm]	17.0" [432mm]	8.07" [205mm]	2.082" [52.9mm]	TPDIGMD/UD
DIGGA XD	4.724" [120mm]	22.98" [584mm]	12.0" [305mm]	2.490" [63.2mm]	TPDIGXD
ESKRIDGE 1-1/4"	1.260" [32mm]	14.00" [356mm]	6.38" [162mm]	0.969" [24.6mm]	TPESD767778
ESKRIDGE 1-1/2"	1.500" [38mm]	14.00" [356mm]	6.38" [162mm]	0.969" [24.6mm]	TPES767778
ESKRIDGE 2"	2.000" [51mm]	16.94" [430mm]	6.38" [162mm]	1.093" [27.8mm]	TPES75
ESKRIDGE D440-D1400	4.000" [102mm]	24.66" [627mm]	16.19" [411mm]	2.125" [54.0mm]	TPESD1400
ESKRIDGE DH375	4.500" [114mm]	39.62" [1007mm]	29.25" [743mm]	2.275" [57.8mm]	TPESDH375



Distributor:

INNOVATIVE

FOUNDATION SOLUTIONS LTD.

www.ifsequip.com