



2013-2017 Gen V Viper Carbon Fiber Side Engine Braces

Overview:

The carbon fiber / aluminum side/lateral engine braces replace the OEM steel braces with the intent to reduce weight, reduce corrosion over time, improve performance, and cosmetically improve the engine compartment.

Compatibility:

These parts will fit any 2013-2017 Viper.

Construction:

The braces are constructed from hard anodized aluminum pieces bonded to high strength carbon fiber tubing and stainless steel and high strength steel hardware. High strength mounting bolts are included with the kit.

Weight:

The side brace pair saves about 7.7 lbs from the front of the engine bay.



Passenger Side Lateral Carbon Fiber Engine Brace Installed

Ordering Information:

<http://dougshelbyengineering.com/Viper.html>

DSE-VP-EB-002: Gen V Viper Carbon Fiber Side Engine Braces

Installation Guide:

Side Brace Removal -

- Ensure the vehicle is on flat level ground or support via the frame (lift or jackstands).
(Removal and installation are easier if the chassis is not unevenly stressed).
- Remove the X brace.

23 - Body / Exterior / BRACE, Engine Box Reinforcement / Removal

Removal

1. Open the hood.
2. Remove the eight fasteners (1) securing the engine box reinforcement brace (2) to the longitudinal reinforcement (3).
3. Remove the engine reinforcement brace (2) from the vehicle.

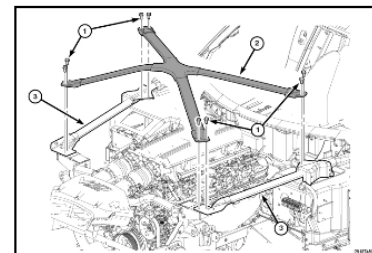

- Remove the engine cowl.

REMOVAL

1. Remove the wiper arms (3), ([Refer to 08 - Electrical/8R - Wipers/Washers/ARM, Wiper/Removal](#)).

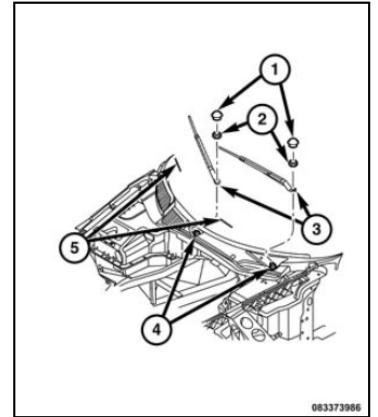

2. Remove the screws and remove the cowl screens.

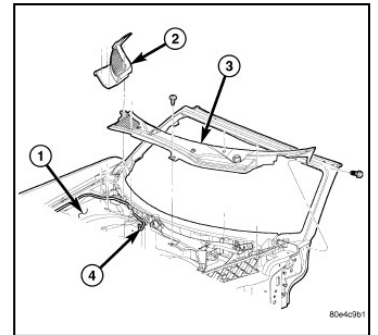

- Take note of the following locations and measurements on the passenger and driver side. Note them for the final installation. Photos may be helpful to ensure you have returned the pieces to their original location.
 - Hood to sill body gap
 - Hood to sill body flushness
 - Height of rubber hood bump stop above the surface of the rear mount area (not rear brace flange surface).
 - Hood latch mounting angle (use phone app or level for measurement, otherwise mark with sharpie on hood release and take photos).
- Remove the 2 bolts connecting the hood latch to the lateral brace and lay aside.

NOTE: Right side shown, left side typical.

2. With the use of a grease pencil or equivalent, mark the position of the hood latch (2) on the longitudinal reinforcement.
3. Remove hood latch fasteners (3).

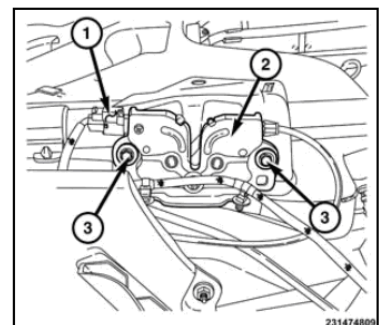

- Remove the hoses/lines attached to the lateral brace forward of the hood latch on the passenger side and at the rear mount on the passenger side.
- If you have DSE catch can(s) installed remove and lay aside (keeping hoses connected). Clean the adhesive from the clamps.
- Remove the bolt connecting the front side of the lateral brace to through the wheel well area.
- Remove the 3 nuts on the rear brace.
- Remove the brace from the car carefully to ensure all connections have been separated from the brace itself.
- Remove the rear rubber bump stops and transfer to the new braces (height can be adjusted before installation by laying the rear flange on a flat surface and measuring as was done on the old brace prior to removal)
- Remove the screw nut clips from the rear flanges and transfer to the new braces.

4. With the use of a grease pencil or equivalent (1), mark the longitudinal reinforcement (3) location.
5. Unfasten wiring and cable routing clips (4).
6. Position hood latch (2) aside.

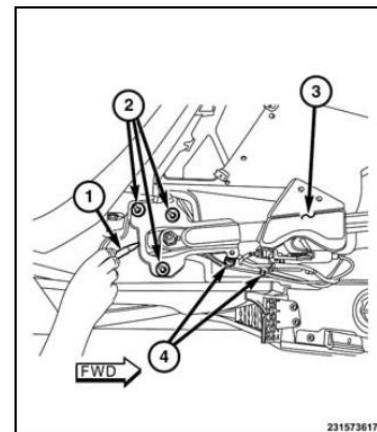

7. Remove the longitudinal reinforcement fastener (2) from within the wheelhouse (1).

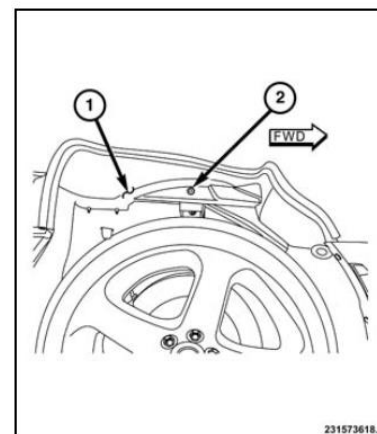

8. Remove the three nuts (2) securing the longitudinal reinforcement (1) to the dash panel (3).
9. Remove the longitudinal reinforcement (1) from the vehicle.

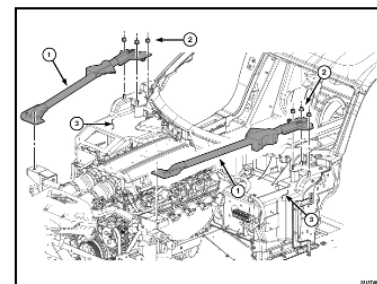

Side Brace Installation –

- Lay the braces in place. Install the front bolts first through the X brace. Alignment is most critical for the smallest hole on the front of the X brace area and it should be installed first.
- If the small hole does not align well attempt to adjust by forcing the brace in the direction required and start the bolt (carefully so that it is not cross-threaded)
- The hand-built nature of the car and suspension loading may require further adjustments. If the front small hole cannot be aligned with reasonable force on the brace, loosen the 3 socket cap screws connecting the tube mount to the front mounting flange. This should allow further adjustment if required. Install both front X-brace bolts and tighten the 3 socket cap screws.
- With the 2 front X brace bolts started and the 3 front tube mount bolts tightened, start the 3 nuts at the rear flange.
- Start the bolts at the rear X-brace mount.
- Start the bolt connecting the front flange to the wheel well area. **(NOTE THIS TORQUE IS INCCORRECT IN THE MANUAL BELOW, TIGHTEN TO 11 Nm , 8 ft lbs)**
- With all bolts started and in place, proceed with the tightening procedure for each. (details below).
- Install the hood latch using the new shorter bolts provided with the kit for the rearward mount. (refer to your measurements, marks, and photos taken before removal).

Side Brace Installation (continued)

23 - Body / Exterior / REINFORCEMENT, Longitudinal / Installation

Installation

1. Align the longitudinal reinforcement (3) to the marks (1) previously made during removal procedure.

2. Connect the latch wiring and cable routing clips (4).

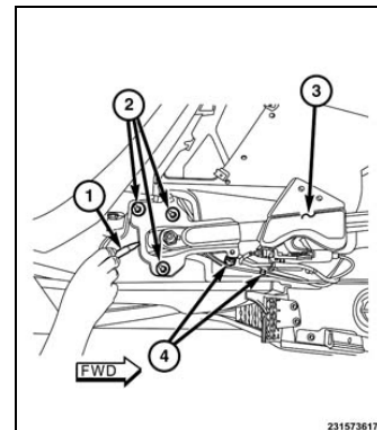

3. Install the three nuts (2) securing the longitudinal reinforcement (1) to the dash panel (3) and tighten to 28 N·m (21 ft. lbs.).

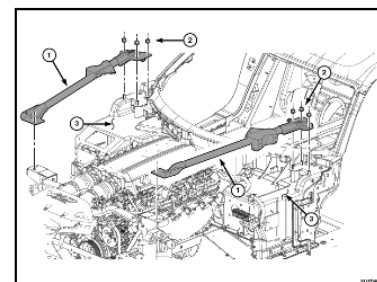

4. Install the longitudinal reinforcement fastener (2) through the wheelhouse (1) and tighten to 28 N·m (21 ft. lbs.).

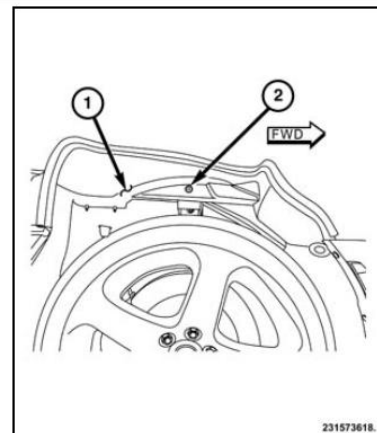

5. Align the hood latch (2) to the marks previously made on the longitudinal reinforcement.

6. Install hood latch fasteners (3) and tighten to 11 N·m (8 ft. lbs.).

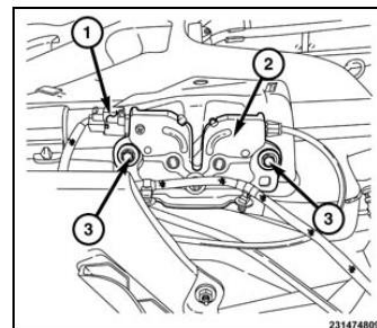

Side Brace Installation (continued)

23 - Body / Exterior / BRACE, Engine Box Reinforcement / Installation

Installation

1. Position the engine box reinforcement brace (2) to the vehicle.
2. Align the engine box reinforcement brace (2) to the longitudinal reinforcements (3).
3. Insert the eight fasteners (1) and tighten to 20 N·m (15 ft. lbs.).

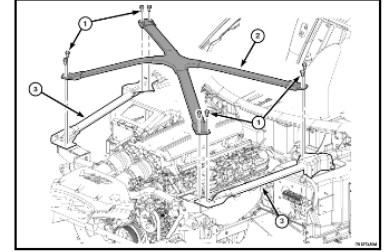

- Secure the harness and tube that was strain relieved on the brace previously. The passenger side tube mounting location moves to the forward inner hole on the rear flange. The driver side can be installed with the included tywrap if desired.
- Close the hood to test fit the gaps. Make adjustments as necessary.
- Reinstall the catch can(s) per the installation instructions using the new tape on the clamp and tywraps provided.
- Reinstall the cowl.

Factory Hood to Sill Body Gaps

5.0 +/- 1.0
Fore / Aft Front and Rear 0.0 +/- 1.5

Hood Over Flush 1.5 +/- 1.0

23 - Body / Exterior / COVER, Cowl Panel / Installation

INSTALLATION

1. Install the cowl screen panels and install the screws and tighten securely.
2. Install the wiper arms (3). ([Refer to 08 - Electrical/8R - Wipers/Washers/ARM_Wiper/Installation](#)).

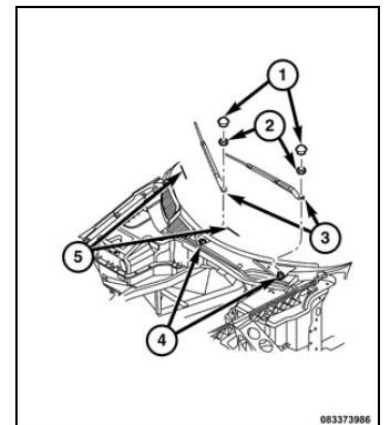
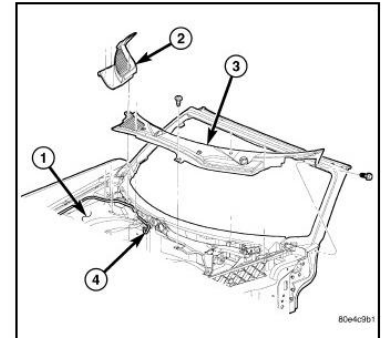

Inspection and Maintenance:

- Periodically inspect the brace to ensure everything is in place as installed including hoses and lines secured to the brace.

Doug Shelby Engineering

<https://www.facebook.com/dougshelbyengineering>

Email: dshelby1@hotmail.com

<https://www.instagram.com/dougshelbyengineering/>

Viper Owner / VOA Member and Sponsor

<http://dougshelbyengineering.com/Viper.html>

Thank you for your purchase!

Your business is appreciated and customer satisfaction is our top priority! Don't hesitate to contact us via email with any questions or feedback. Word of mouth is the best form of advertising so if you are satisfied please spread the word!

Disclaimer of Liability:

Doug Shelby Engineering assumes no liability expressed or implied for the improper installation or use of this product or its components. Doug Shelby Engineering is NOT responsible for any damage, consequential or otherwise for equipment failure after installation.

Vehicle Modification:

Modification of your vehicle with the parts identified above may alter its stock performance; the buyer hereby expressly assumes all risks associated with any such modification.

Disclaimer of Warranty:

Seller disclaims any warranty express or implied with respect to the parts sold hereby whether as to merchantability, fitness for particular purpose, or any other matter.