

SERIES



SWISS MADE



PRECISION BALANCES

Equilab s.r.l.
Equipos para laboratorios

Servicio de
Calibración
Suizo





PRECISA DNA: ZERO TOLERANCE.

Discerning technicians in the laboratory and research institutes are well aware of the critical importance of the results they deliver. That is why they are simply not prepared to compromise on their working equipment. This is exactly why leading specialists around the world count on Precisa, and have done so for decades.

Steffen Wander
General Manager

PRECISA DNA: SWISS PRECISION.

Precisa products are prime examples of Swiss perfection and reliability. They are tried and tested in discerning laboratory environments and in the industrial segment, and are subject to rigorous quality controls throughout the entire manufacturing process. Precisa continuously invests in new technologies and employs a highly qualified team of engineers and researchers. The result is a state-of-the-art range of precision instruments fit for the strictest demands.

Roger Grolimund
Head Research & Development

PRECISA DNA: SERIES 520.

Swiss idea, Swiss development, Swiss production. With over 40 years knowledge and experience, Precisa Gravimetrics AG has developed one of the most important innovations in weighing technology in recent years. The Precisa PHASTbloc™ weighing cell allows you to benefit from this advanced technology and provides a technically perfect, easy-to-use, attractive, economical and sustainable balance. Discover the innovations of the 520 series. We look forward to inspiring you - as many users have been already.

Mizuki Yuasa
Product Manager



PHASTbloc™

Precisa Hybrid Advanced Sensor Technology

PHASTbloc™ - Precisa's new and unique weighing technology combines the benefits of current weighing cells with monolithic design.

The ultimate in Swiss engineering from Precisa has created a world first weighing technology, representing 40 years of knowledge and expertise in developing weighing technologies and innovations.

The sustainable hybrid approach in the PHASTbloc™ unites the benefits of a conventional weighing cell and monolithic design. This enables the efficient maintenance and repair of a weighing cell instead of replacing it - sustainability in practice. Advanced materials, engineering and unique manufacturing methods lift quality and performance to new heights.

Using a range of materials such as standard grade and high tech aerospace aluminium, maximises reparability and performance,

offering affordability and an environmentally friendly product. All parts of the PHASTbloc™ are manufactured with the highest Swiss quality and precision. The division of the weighing cell into functional parts not only allows an optimal choice of material and manufacturing process for each section, but also opens up the possibility of replacing parts. This allows the PHASTbloc™ to be maintained costeffectively and ensures a long life.

All this makes the PHASTbloc™ weighing cell the most ecological and economical of its kind without compromising on performance.

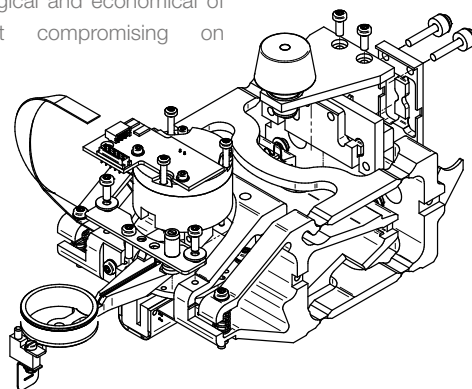
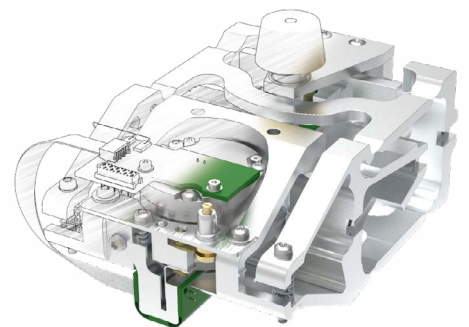

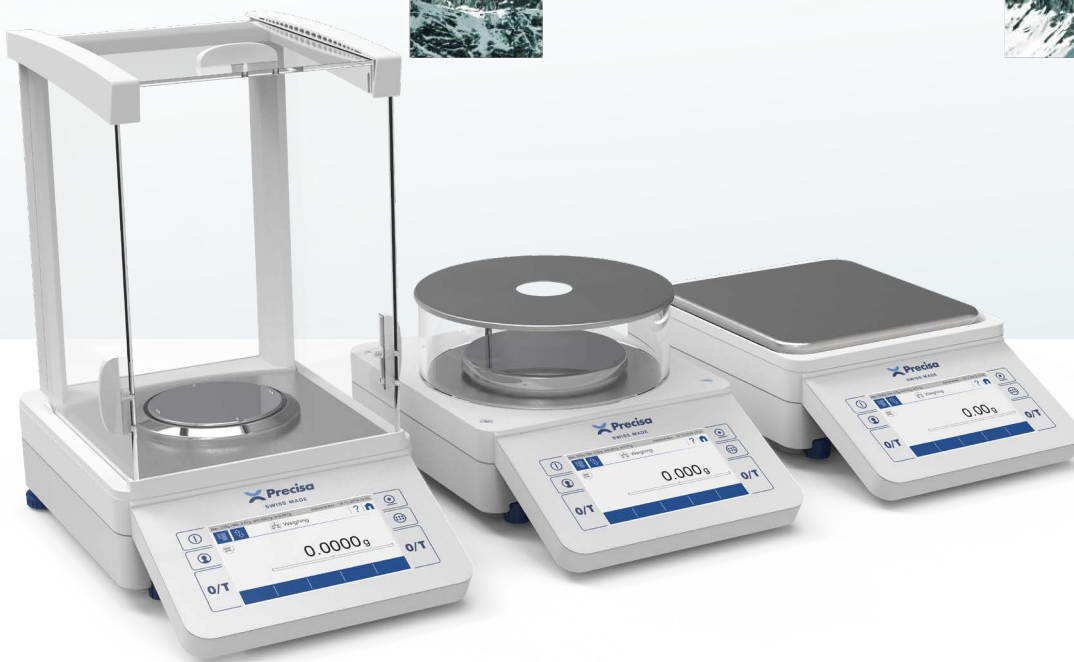

520 PT THE SMART BALANCE

With a 6.4" touch control screen, this is the largest in its class!

In working environments such as laboratories, research and development, where flexibility and individual user solutions are required, the Model 520 PT reveals its full potential. With the advantages of the touch screen in terms of visualization, intuitive operation and customization options, the 520 PT offers the highest degree of flexibility, safety and user-friendliness.

Six large fixed keys for the most common operating functions - on/off switch, tare, printing, user and application selection - optimize operation without reducing the display area.

With a complete range of applications such as counting, density, animal weighing, percentage, check, ... and the RS232, USB, plus optional Ethernet, WiFi and Bluetooth interfaces, there are no limits to the 520 PT.

The 520 PT with its touch screen is the right choice for maximum user-friendliness and flexibility.

Features

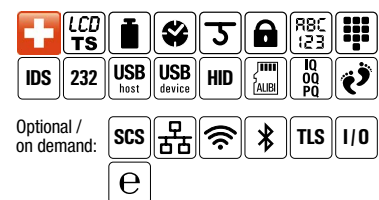

Applications

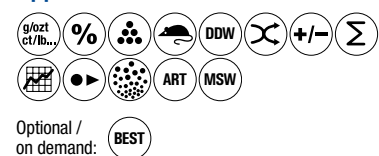

See Features / Applications for an explanation of terms and comparison with 520 PB.

SERIES 520 PT FEATURES

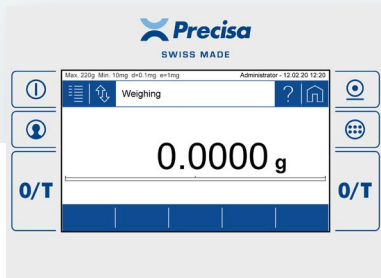

TOUCH SCREEN

Large 6.4" touch-sensitive user interface with an elegant and bright 5" colour display.

As with mobile devices, the balance's user interface is intuitive and easy to use. Precisa's user-friendly operating concept makes navigation and configuration much easier thanks to the colour scheme.

The desired application is just a fingertip away. The colour logic displays all touchactive surfaces in blue. The "Home" button, which is always available, guides you back to the active application.

Specifications:

- 6.4" touch-sensitive user interface
- 5" anti-reflective display
- Shock and scratch resistant
- Suitable to operate with laboratory gloves
- UV resistant
- Frameless for easy and thorough cleaning.

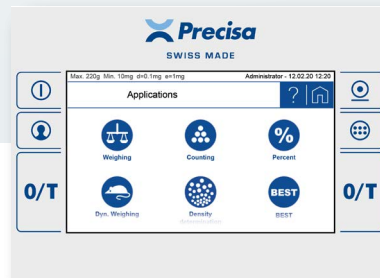

6 FIXED KEYS

Six quick-select keys with the most important functions.

To the right and left of the display there are three fixed position touch-sensitive keys. This gives you access at all times to the most important functions: switch on/off, print, application and user screen as well as taring or zeroing.

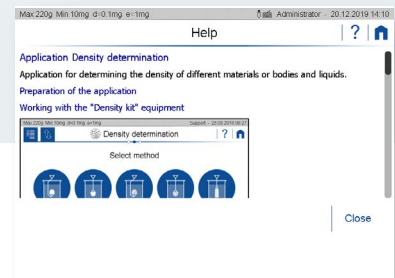

CONTEXT HELP

We simplify your life!

Simply touch the help icon and the context help appear on screen. You will find all relevant information, even if you are in an application, the context menu, the user screen or anywhere else. Help is available at the touch of a button! No more tedious and time-consuming browsing through user manuals.

SERIES 520 PT FEATURES

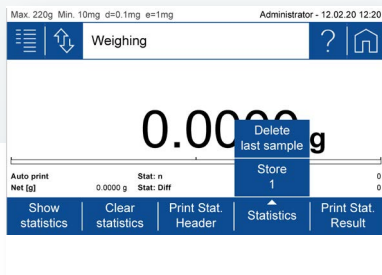

CUSTOMIZE YOUR SCREEN

Individual and efficient

The display of the 520 PT series can be fully adapted to suit your requirements. You decide what information is displayed in the notification area.

Six soft buttons can be freely configured in the action bar. Assign the most important functions to them or create a folder with up to four commands. Complex functions and processes are simplified in this way so that you can concentrate on your main tasks.

Nothing stands in the way of simple, efficient and safe work.

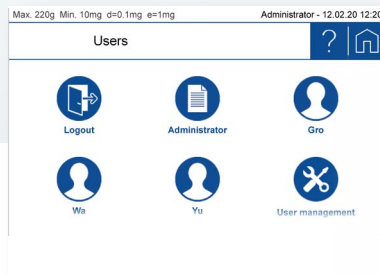

USER MANAGEMENT

Individual and secure

With the built-in, extensive user management, your balance can be optimally adjusted for up to 15 users.

Simply select your profile at the start of work and the balance loads your personal settings.

The balance's individual configuration is saved in your user profile: whether with full access rights, restricted to a single application or simply with the basic operating settings for right-handed or left-handed users. Each profile can be protected with a unique password.



ELECTRONIC LEVEL INDICATOR

Improved precision

With the built-in electronic levelling, you can be assured that your balance is level at all times. If the balance is no longer level, a message appears on the display. The balance can also be configured so that it can only be operated when level.

To reset the position of the balance correctly, a levelling guide is displayed on the screen. It shows which direction the feet need to be moved.

SERIES 520 PT FEATURES



COMMUNICATION & INTERFACES

Unlimited connectivity

The 520 PT Series meets your communication needs. Whether you already have a LIMS in a paperless laboratory or not.

We offer the balance with a range of standard interfaces:

- USB type A (host)
- USB type B (device)
- RS232
- 10/100M Ethernet (optional)
- Wi-Fi (optional)

The integration of your balance into the network, and the connection to a PC or printer is very easy.





520 PB TIMELESS AND PROVEN IN EVERYDAY PRACTICE

Five high-quality mechanical membrane keys guarantee longevity and a tactile feel with clearly noticeable feedback to the user.

The Model 520 PB is also suitable for laboratories, the pharmaceutical, food, light and consumer goods industries as well as production or for pharmacies and jewellery.

Wherever precise and demanding routine work is carried out on a regular basis, reliability and user-friendliness are key components.

State-of-the-art with an extensive range of applications such as counting, density, animal weighing etc.

Including statistics, a wide range of languages, RS232 and USB interfaces, all current and future requirements are met.

It has never been so easy to choose the right balance.

Features

Optional / on demand:						

Applications

See Features / Applications for an explanation of terms and comparison with 520 PT.

SERIES 520 PB FEATURES



ROBUST AND DURABLE DESIGN

Designed for almost any environment

When designing the 520 PB series, attention was paid to robustness and durability. The housing materials, keyboard and display were chosen to withstand rough environments and meet heavy demands.



LARGE ALPHANUMERIC LCD

Large and easy to read

The bright, high-contrast LC display with backlight and large digits (> 15mm) offers excellent readability.

FIVE KEYS MEMBRANE KEYPAD

Clear and simple

The five softkeys structure the various application possibilities in a user-friendly manner and considerably improve the operation of the device.

Navigation has been enhanced and simplified for the 520 PB series.

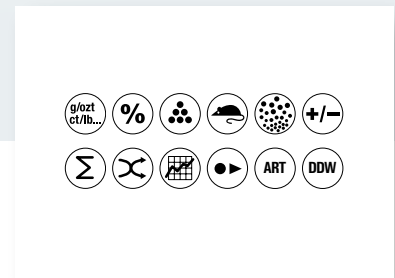

EXTENSIVE RANGE OF APPLICATIONS

Advanced functionality

The desired application can be easily selected from a large number of specific applications and guarantees maximum functionality. The 520 PB series offers an extremely wide range of applications for almost every possible application.

COMMON FEATURES



STURDY HOUSING

Robust and durable

Precisa's instrument housings have always been characterized by their robustness and longevity. This has not changed with the current Series 520.

Both the new PHASTbloc™ weighing cell and the entire balance have been designed for optimal material choice. For this reason, the base is a robust die-cast aluminium housing and the upper part is made of fibreglass-reinforced and durable plastic.



STABILITY INDICATOR

Real-time stability indicator with stability prediction

The optical stability indicator indicates measurement faults and provides real-time information on the influences of the environment which may affect the balance.

The more stable the environment, the faster the stability indicator disappears and a reliable value is displayed. The stability indicator allows estimating how long it takes for the balance to display a reliable value.

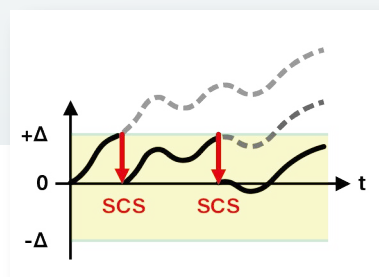

INTERNAL CALIBRATION (SCS)

Always accurate

The self-calibration system (SCS) developed by Precisa enables automatic adjustment / calibration of the balance. The function can be set to be temperature and/or time-controlled, so that the user can always expect maximum measuring accuracy. This option is often used in regulated environments (GLP).

COMMON FEATURES

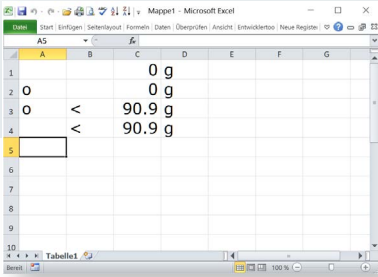

HUMAN INPUT DEVICE (HID)

Direct balances - PC communication

The balance can be connected to a computer via a USB cable and is recognized by the computer as a human input device (HID). This turns your balance into a keyboard and weight values can be sent directly from the balance to the PC without installing any software. No additional authorizations, apps or tools are required. In this way, the data can be written directly into the open program, for example Excel, Word, Notepad, etc.



USB (FLASH DRIVE)

Saving data on a USB memory stick

Data such as weight values or reports can be saved directly to a connected USB memory stick. This allows them to be processed on a PC that is not connected.

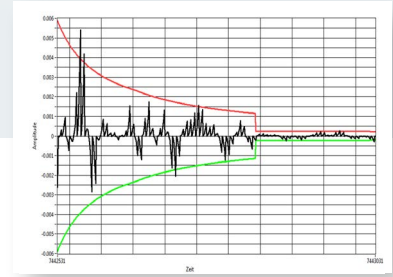

OTHER FEATURES

Suitable for a wide range of use

- Multilingual
- Improved digital filter to eliminate external effects
- Space saving
- Maximum stability, thanks to four adjustable feet
- Weighing below option
- Optionally IP65 protected

FEATURES APPLICATIONS



Features	PB	PT
Swiss made	✓	✓
Colour Touch Screen	-	✓
Backlit LCD	✓	-
Self-Calibration-System, fully automated	optional	optional
External Calibration (with calibration warning)	✓	✓
Clock (GLP/GMP printout, auto-cal, etc.)	✓	✓
Below balance weighing	✓	✓
Anti-theft protection (mechanical and code)	✓	✓
Easy alphanumeric input	-	✓
Direct tare and reference weight entry	-	✓
Identifier and label handling	-	✓
RS232 interface (PC / Printer)	✓	✓

Features	PB	PT
USB host (barcode, flash drive, ...)	✓	✓
USB device (to PC)	✓	✓
Human Interface Device (to PC)	✓	✓
Ethernet connection	on demand	350-8939
WiFi connection	on demand	350-8953
Bluetooth connection	on demand	on demand
Touch-Less-Sensor (Draft shield, tare, print, ...)	on demand	on demand
External I/O (Tare, Print, ..., Relais)	on demand	on demand
EU/OIML type approval	on demand	on demand
Integrated Alibi Memory (as part of EC-Verification)	✓	✓
Support IQ/OQ/PQ	✓	✓
Integrated Audit Trail	-	✓

Applications	PB	PT
Units g, mg, ozt, lb, tael, etc.	✓	✓
Percent weighing	✓	✓
Piece counting	✓	✓
Animal weighing	✓	✓
Dynamic Difference Weighing	✓	✓
Free conversion, Area conversion	✓	✓
Check weighing	✓	✓

Applications	PB	PT
Net total application (Add up summation, Dosing)	✓	✓
Statistics	✓	✓
Recorder	✓	✓
Density determination (liquids, solids, ...)	✓	✓
Automatic Repeatability Test	✓	✓
Minimum Sample Weight	-	✓
Buoyancy Error Suppression Technology * release code for report printout	-	* 350-8739-001

OPTIONS ACCESSORIES



Options	PB	PT
EC-Verification and alibi memory according to 2014/31/EU by Precisa (initial verification) available only for balances with EC/OIML Type approval and SCS	on demand	on demand
Protection IP65, protection against ingress of dust and low pressure water jets, fitted at factory, not all types available	on demand	on demand

Applications	PB	PT
BEST Buoyancy Error Suppression Technology	–	350-8739-001

Accessories	PB	PT
Draft shield PB, short	350-8742	350-8742
2nd Display	on demand	–
Carat bowl (for diamond weighing)	350-8322	350-8322
Animal weighing bowl complete for 0.01g, 0.1g and 1g balances	350-8743	350-8743
Hook for weighing below the balance	350-8744	350-8744
Anti-theft cable	350-8555	350-8555
Density kit for 0.1mg balances Container size Ø= 75mm, h= 100mm	350-8740	350-8740
Density kit solids only (w/o Glass body and Hook) for 0.1mg balances Container size Ø= 75mm, h= 100mm	350-8741	350-8741
Glass body 10ccm for density determination of liquids	350-7054	350-7054
Downholder for samples with density < 1 g/cm3	350-7194	350-7194
Signal Lamp, indicator with 3 lamps, green / red / yellow	350-8734	350-8734
Horn for Signal Lamp	350-8533	350-8533
Single foot switch USB for one function e.g. tare, print, ...	350-8747	350-8747
Double foot switch USB for two functions e.g. tare and print, tare and ...	350-8748	350-8748
Ethernet connection	on demand	350-8939
WiFi connection	on demand	350-8935
External USV accu power pack for continuous operation	350-8662	350-8662
Data cable DB9m-RJ45, crossed, length 1.5m, for balance used as reference balance	350-8661	350-8661
Data cable DB9m-DB9f, length 1.5m (to PC or Printer LP 4024)	350-8672	350-8672
Data cable DB9m-DB25m, length 1.5m (to Printer CBM910)	350-8673	350-8673
Dust cover 520 for the whole balance, set of 5 pieces	350-8745	350-8745
Carrying case 520	350-8746	350-8746
Printer LP4024, 230V / 115V	350-8391	350-8391
Paper roll for Printer LP4024, set of 4 pcs	350-8392	350-8392
Ribbon for Printer LP4024	PN 3953-013	PN 3953-013





SERIES 520 | Px 0.1 mg

Model	Capacity	Readability	Repeatability (load > 5%)	Min. weight (1%, k = 2)	Linearity	Pan Size (mm)	Class / „e“	Response time	Item No.
PB/PT 120A	120 g	0.1 mg	0.1 mg	20.0 mg**	0.2 mg	Ø 90	I / 1 mg	2 s	520-92y1-00x*
PB/PT 220A	220 g	0.1 mg	0.1 mg	20.0 mg**	0.2 mg	Ø 90	I / 1 mg	2 s	520-92y2-00x*

Net weight 6.6 kg, Sensitivity drift (10–30°C) 1.5 ppm / °C



SERIES 520 | Px 1 mg

Model	Capacity	Readability	Repeatability (load > 5%)	Min. weight (1%, k = 2)	Linearity	Pan Size (mm)	Class / „e“	Response time	Item No.
PB/PT 320M	320 g	1 mg	1 mg	200 mg**	1.5 mg	Ø 120	II / 10 mg	1.5 s	520-93y1-00x*
PB/PT 620M	620 g	1 mg	1 mg	200 mg**	1.5 mg	Ø 120	II / 10 mg	1.5 s	520-93y2-00x*

Net weight 5.6 kg, Sensitivity drift (10–30°C) 2.0 ppm / °C



SERIES 520 | Px 0.01 g

Model	Capacity	Readability	Repeatability (load > 5%)	Min. weight (1%, k = 2)	Linearity	Pan Size (mm)	Class / „e“	Response time	Item No.
PB/PT 320C	320 g	0.01 g	0.005 g	1 g**	10 mg	186 x 186	II / 0.01 g	1.5 s	520-94y1-00x*
PB/PT 620C	620 g	0.01 g	0.005 g	1 g**	10 mg	186 x 186	II / 0.1 g	1.5 s	520-94y2-00x*
PB/PT 1200C	1200 g	0.01 g	0.01 g	2 g**	10 mg	186 x 186	II / 0.1 g	1.5 s	520-94y3-00x*
PB/PT 2200C	2200 g	0.01 g	0.01 g	2 g**	15 mg	186 x 186	II / 0.1 g	1.5 s	520-94y4-00x*
PB/PT 3200C	3200 g	0.01 g	0.01 g	2 g**	15 mg	186 x 186	II / 0.1 g	1.5 s	520-94y5-00x*
PB/PT 4200C	4200 g	0.01 g	0.01 g	2 g**	15 mg	186 x 186	II / 0.1 g	1.5 s	520-94y6-00x*

Net weight 5.6 kg, Sensitivity drift (10–30°C) 2.0 ppm / °C



SERIES 520 | Px 0.1 g / Px 1 g

Model	Capacity	Readability	Repeatability (load > 5%)	Min. weight (1%, k = 2)	Linearity	Pan Size (mm)	Class / „e“	Response time	Item No.
PB/PT 3200D	3200 g	0.1 g	0.05 g	10 g**	0.1 g	186 x 186	II / 0.1 g	1 s	520-95y1-00x*
PB/PT 6200D	6200 g	0.1 g	0.05 g	10 g**	0.1 g	186 x 186	II / 1.0 g	1 s	520-95y2-00x*
PB/PT 10200D	10200 g	0.1 g	0.1 g	20 g**	0.15 g	186 x 186	II / 1.0 g	2 s	520-95y3-00x*
PB/PT 10200G	10200 g	1 g	0.5 g	100 g**	0.5 g	186 x 186	II / 1.0 g	1.5 s	520-96y1-00x*

Net weight 5.6 kg, Sensitivity drift (10–30°C) 2.0 ppm / °C

COMMON SPECIFICATIONS

Floating display	Temperature range	Line voltage, Tolerance	Stability settings	Power consumption	Frequency
Adjustable	5–40 °C	115V / 230V, +15% / -20%	Adjustable	18 VA	50–60 Hz

*x = 1 for balance with SCS / x = 2 for balance without SCS

**y = 1 for model PB / 2 for model PT

** USP Min. weight (0.1%, k=2, load > 5%) = 10 x Min. weight (1%, k=2)

PRECISION BALANCES
0.01 g / 0.1 g / 1 g

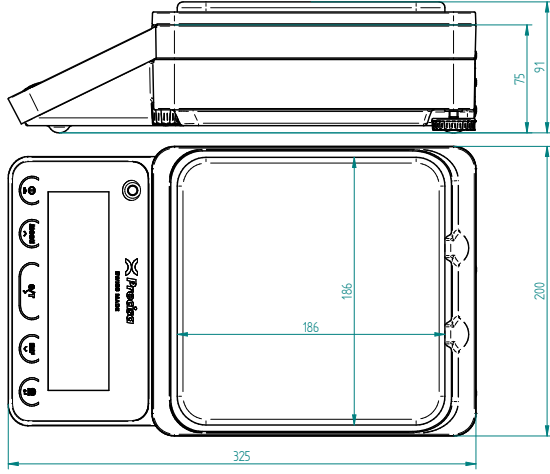

PRECISION BALANCES
1 mg

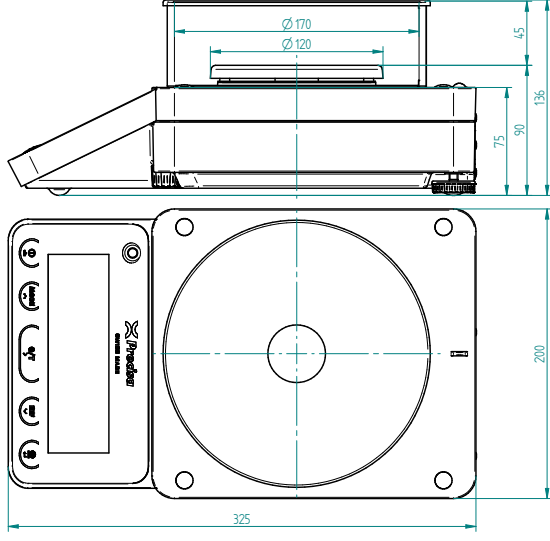

ANALYTICAL BALANCES
0.1 mg

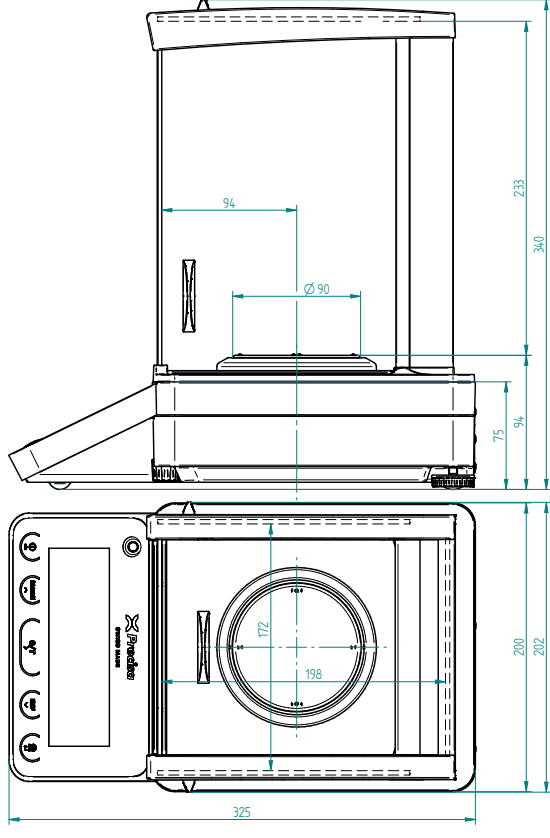

THE TECHCOMP GROUP

The following companies belong with Precisa to the internationally active Techcomp Group:



Precisa Gravimetrics AG
Moosmattstrasse 32
8953 Dietikon, Switzerland
Tel. +41 44 744 28 28
Fax +41 44 744 28 38
Email: info@precisa.ch
www.precisa.com



Equilab s.r.l.
Equipos para laboratorios

Servicio de Calibración Suizo

**Distribuidor Autorizado
Servicio Técnico**

Calle Salvador Estrella Sadhalá 6B, Gazcue
10205 Santo Domingo - República Dominicana
T: +1 (809) 412-7828, M: (809) 708-4000
bruno@equilab-rd.com, www.equilab-rd.com

RNC: 1-3099457-9
RPE: 60045

