

Mac Tools

MODEL LFMR6

PORTABLE MID-RISE LIFT

(6,000 lb Capacity)

**INSTALLATION, OPERATION AND
MAINTENANCE MANUAL**

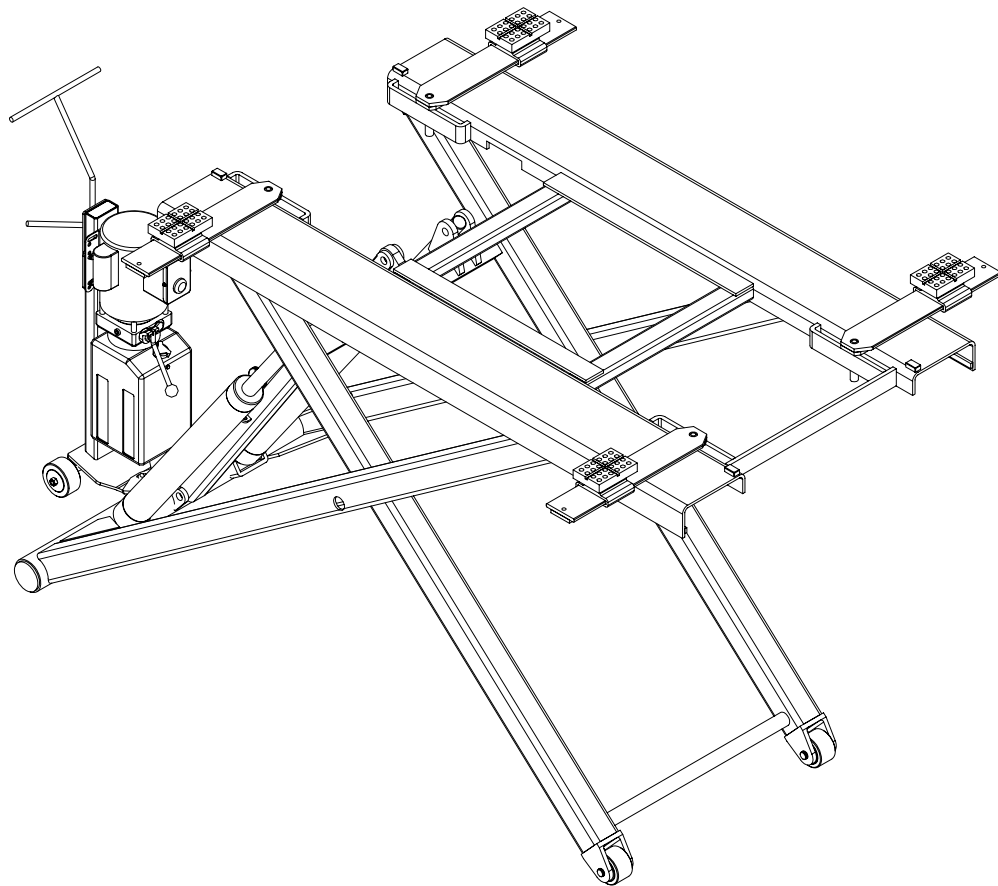

IMPORTANT!!!

**READ THIS MANUAL COMPLETELY BEFORE INSTALLING OR
OPERATING THE LIFT**

*200 CABEL STREET, P.O. BOX 3944
LOUISVILLE, KENTUCKY 40201-3944*

E-Mail - sales@challengerlifts.com

Web Site - www.challengerlifts.com

OFFICE (502) 625-0700

FAX (502) 587-1933

GENERAL SPECIFICATIONS

Maximum Capacity	6,000 lbs
Minimum Table Height	5 1/2 inches
Maximum Table Height	53 1/4 inches
Electrical Requirements	115V, 50/60 Hz, 1 phase
Lifting Time.....	45 seconds
Safety Lock	System Mechanical Safety Lock

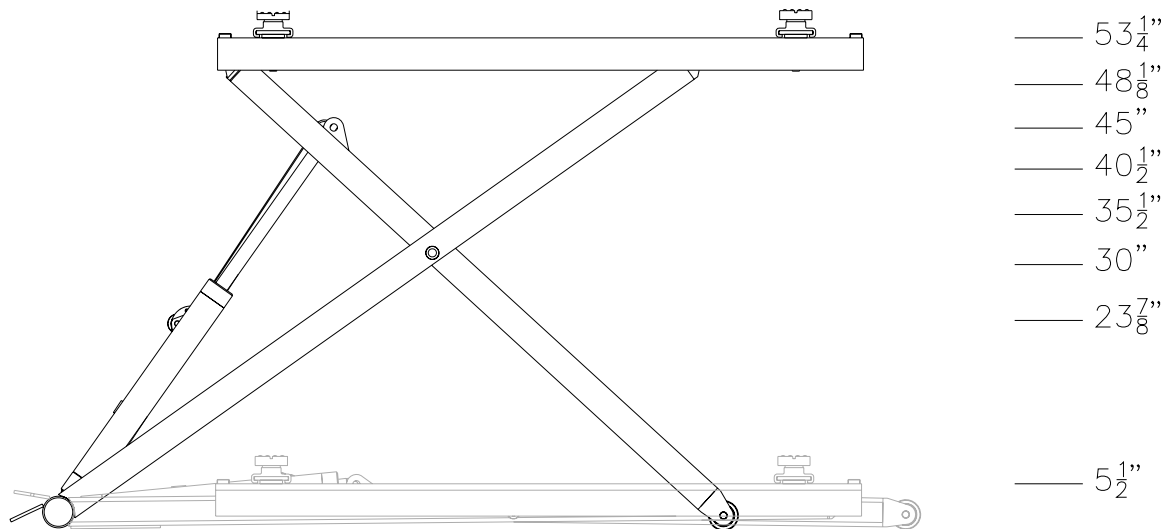
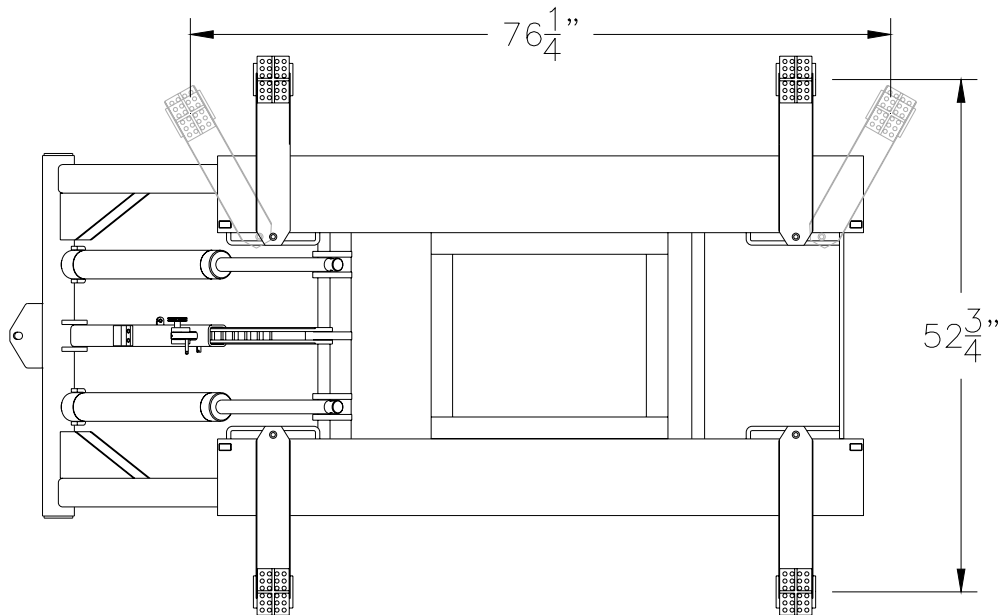

Before You Begin

Safety Notices and Decals
For you safety, and the safety of others, read and understand all of the safety notices and decals included here.

Read entire manual before assembling, installing, operating, or servicing this equipment.

Proper maintenance and inspection is necessary for safe operation.

DO NOT operate a damaged lift.

Safety decals similar to those shown here are found on a properly installed lift. Be sure that all safety decals have been correctly installed on the lift. Verify that all authorized operators know the location of these decals and fully understand their meaning. Replace worn, faded, or damaged decals promptly.

SAFETY WARNING LABELS FOR HINGED FRAME ENGAGING LIFTS

Lift Owner/User Responsibilities:

- A. This Safety Warning placard **SHALL** be displayed in a conspicuous location in the lift area.
- B. Use one of the mounting arrangements illustrated on back of this placard.
- C. These Safety Warning labels **SHALL** supplement other documents supplied with the lift.
- D. Be certain all lift operators read and understand these labels, operating instructions and other safety related information supplied with the lift.

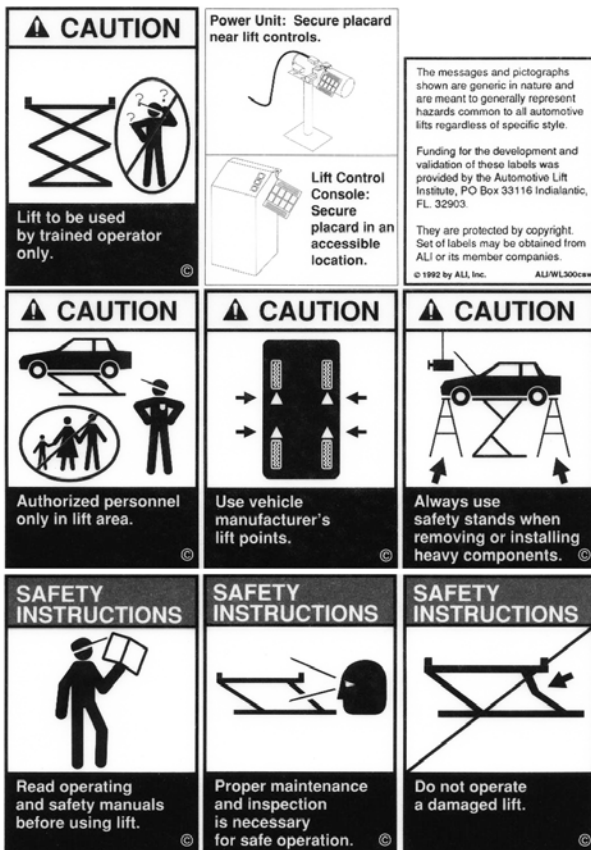

Do not attempt to raise a vehicle on the lift until the lift has been correctly installed and adjusted as described in this manual.

Electrical Requirements

For lift installation and operation, it is necessary to have a dedicated 115V single-phase 60-cycle circuit with a 20 amp circuit breaker or time delay fuse.

Tools Required for Installation

1. Wrenches: 7/16, 1/2, 9/16, 5/8, 11/16, 15/16, 1 1/8 inch
2. Ratchet drive with the following sockets: 7/16, 1/2, 9/16, 1 1/8 inch
3. Funnel
4. Adjustable wrenches: 8 and 12 inch

Installation

1. Locate the lift on a level concrete floor with adequate space on all sides. Minimum floor thickness is 4". Minimum floor strength is 3500 psi.

 **WARNING DO NOT** install on asphalt or other similar unstable surface.

 **CAUTION** If lift is to be used in a paint booth, the electrical power unit **MUST** be mounted outside the booth.

Power Unit

1. Connect the end of the hydraulic hose with the 90-degree elbow to the pressure port on the power unit. Tighten securely to prevent leaking.
NOTE: To avoid damage to the hose, never run the hose under the lift or in the path of the automobile tires.
2. Fill the reservoir with 6 quarts clean 10wt anti-foam, anti-rust hydraulic oil or Dexron III ATF.
DO NOT USE OILS WITH DETERGENTS.
3. Place the open end of the hose into a clean bucket.
4. Plug power unit cord into a dedicated 115V single phase 60 cycle circuit with a 25 amp circuit breaker or time delay fuse
5. Cycle the power unit (2 seconds on, 2 seconds off) until the hose expels a steady stream of fluid.
6. Connect the hose to the tee fitting on the lift.
7. Actuate the power unit and raise the lift fully, then lower the lift to the floor. Repeat 3 to 4 times.

Receiving

The shipment should be thoroughly inspected as soon as it is received. The signed bill of lading is acknowledgement by the carrier of receipt in good condition of shipment covered by our invoice.



If any of the goods called for on this bill of lading are shorted or damaged, do not accept them until the carrier makes a notation on the freight bill of the shorted or damaged goods. Do this for your own protection.

NOTIFY **Challenger Lifts** AT ONCE if any hidden loss or damage is discovered after receipt

IT IS DIFFICULT TO COLLECT FOR LOSS OR DAMAGE AFTER YOU HAVE GIVEN THE CARRIER A CLEAR RECEIPT.



File your claim with **Challenger Lifts** promptly. Support your claim with copies of the bill of lading, freight bill, and photographs, if available.

Flooring

Be certain you have the proper concrete floor to properly handle the loaded lift. Floor should be in generally good condition with no large cracks, spalling or deterioration. Minimum requirements for concrete are 4 inches minimum depth, with steel reinforcement per local commercial practice, 3500 psi, cured for 28 days. Floor should be level within 1/4 inch over the installation area. If these conditions cannot be met, pads can be poured to accommodate the lift. Pad must be minimum of 8 ft x 8 ft x 1 ft minimum thickness, 3500 psi steel reinforced mechanically attached to existing floor.



Failure by purchaser to provide the recommended mounting surface could result in unsatisfactory lift performance, property damage, or personal injury.

Vertical Clearance

Check the height of the area where the lift is to be installed. Clearance should be calculated based on the full raised height of the lift plus the height of the tallest vehicle you intend to service.



Failure by purchaser to provide adequate clearance could result in unsatisfactory lift performance, property damage, or personal injury.

CAUTION The power unit operates at high pressure.

Raise and lower lift a few times and check hose and fittings for leaks and tighten if required.

Check for binding, misalignment or damage. Correct any unusual condition before raising vehicle.

Owner/Operator Checklist

SAVE THESE INSTRUCTIONS deliver them to owner/user/employee along with other materials furnished with this lift.

Demonstrate the operation of the lift to the owner/operator and review correct and safe lifting procedures using the **Lifting It Right** booklet as a guide.

Safety Notices and Decals

This product is furnished with graphic safety warning labels, which are reproduced on page 3 of these instructions. Do not remove or deface these warning labels, or allow them to be removed or defaced. For your safety, and the safety of others, read and understand all of the safety notices and decals included.

Owner/Employer Responsibilities

This lift has been designed and constructed according to ANSI/ALI ALCTV-1998 standard. The standard applies to lift manufactures, as well as to owners and employers. The owner/employer's responsibilities as prescribed by ANSI/ALI ALOIM-2000, are summarized below. For exact wording refer to the actual standard provided with this manual in the literature pack.

The Owner/Employer shall insure that the lift operators are qualified and that they are trained in the safe use and operation of the lift using the manufacturer's operating instructions; ALI/SM 93-1, ALI Lifting It Right Safety Manual; ALI/ST-90 ALI Safety Tips Card; ANSI/ALI ALOIM-2000; American National Standard for Automotive Lifts-Safety Requirements for Operation, Inspection and Maintenance; ALI/WL Series, ALI Uniform Warning Label Decals/Placards; and in case of frame engaging lifts, ALI/LP-GUIDE, Vehicle Lifting Points/Quick Reference Guide for Frame Engaging Lifts.

The Owner/Employer shall establish procedures to periodically inspect the lift in accordance with

the lift manufacturer's instructions or ANSI/ALOIM-2000, American National Standard for Automotive Lifts-Safety Requirements for Operation, Inspection and Maintenance; and the employer shall insure that the lift inspectors are qualified and they are adequately trained in the inspection of the lift.

The Owner/Employer shall establish procedures to periodically maintain the lift in accordance with the lift manufacturer's instructions or ANSI/ALOIM-2000, American National Standard for Automotive Lifts-Safety Requirements for Operation, Inspection and Maintenance; and the employer shall insure that the lift maintenance personnel are qualified and they are adequately trained in the inspection of the lift.

The Owner/Employer shall maintain the periodic inspection and maintenance records recommended by the lift manufacturer or ANSI/ALOIM-2000, American National Standard for Automotive Lifts-Safety Requirements for Operation, Inspection and Maintenance.

The Owner/Employer shall display the lift manufacturer's operating instructions; ALI/SM 93-1, ALI Lifting It Right Safety Manual; ALI/ST-90 ALI Safety Tips Card; ANSI/ALI ALOIM-2000; American National Standard for Automotive Lifts-Safety Requirements for Operation, Inspection and Maintenance; and in case of frame engaging lift, ALI/LP-GUIDE, Vehicle Lifting Points/Quick Reference Guide for Frame Engaging Lifts; in a conspicuous location in the lift area convenient to the operator.

Operating Instructions

NOTE:

After reviewing these instructions and all decals, get familiar with lift controls by running the lift through a few cycles before loading vehicle on lift.

Loading Vehicle

1. Be sure lift is fully lowered and service bay is clear of all personnel before the vehicle is driven on to lift.
2. Position vehicle over lift having equal distance from front tire to end of front ramps and rear tire to end of rear ramps. Vehicle must also be centered side to side.

⚠ WARNING Lift is designed to raise complete vehicle. **NEVER** use to raise just one end or Side of vehicle.

NOTE:

Some vehicles may have the manufacturer's recommended lift points identified by triangle shape marks located on its undercarriage. Also, there may be a label located on the right front door lock face showing specific vehicle lift points. If the vehicles lift points are not identified, refer to the service garage lift points shown in Fig. 1. **ALWAYS** follow the operating instructions supplied with the lift.

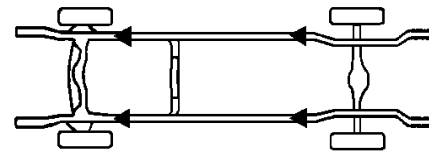

Ladder

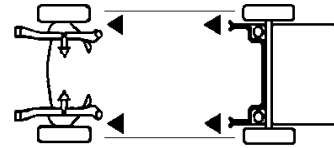

Unitized

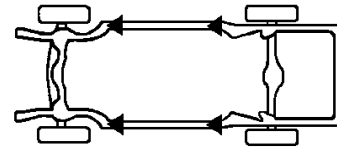

Perimeter

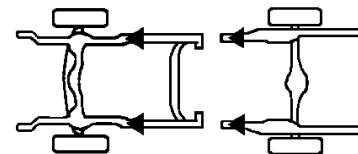

Stub

Fig 1 Service Garage Lift Points

CAUTION Most specialty or modified vehicles cannot be raised on a frame engaging or pad lift. Contact vehicle manufacturer for raising or jacking details.

3. Before lifting the vehicle be sure that:
 - A. Individual axle weight of vehicle does not exceed one-half lift capacity. See safety instructions (capacity).
 - B. Vehicle is stable on lift and neither front nor rear heavy.

 **CAUTION** With some vehicles, the removal (or installation) of heavy components may cause a critical shift in balance and result in vehicle instability. Refer to the vehicle manufacturer's service manual for recommended procedures when performing these services.

Raising Vehicle

4. To raise lift:
 - A. Actuate **RAISE** switch on electric power unit.
 - B. Raise vehicle until tires clear floor.
 - C. Check to make sure all four contact pads are secure on the vehicle.
 - D. Continue to raise to desired height **ONLY** if vehicle is secure on lift.
 - E. Once you have reached the required height set into lock by depressing the lowering handle.

Lowering Vehicle

5. To lower lift:

Stand clear of lift and vehicle when lowering. Observe pinch point warning decals.

 - A. Remove all tools or other objects from lift area.
 - B. Raise vehicle approximately 1" to disengage lock.
 - C. Push **LOWERING** valve handle to lower lift.

 **CAUTION** Lowering handle must be held down to continue to lower lift. **DO NOT** override self-closing lift controls.

6. Before moving vehicle, be sure lift is at the fully lowered position and is clear of any tools or objects.

NOTE:

The lock bar will reset automatically when the lift is fully lowered or raised a minimum of 1". If during the lowering process the lift is stopped before it gets to the fully lowered position. Reset by repeating steps 5 or 6 from above.

MAINTENANCE

NOTE:

To avoid personal injury, permit only qualified personnel to perform maintenance on this lift.

See repair parts breakdown for replacement parts.

ALWAYS: Keep all bolts tight. Check periodically.

ALWAYS: Keep lift clean. Raise lift when cleaning floor area.

DAILY: Check lock bar handle and release mechanism for damage or binding.

WEEKLY: Inspect all lift parts for signs of damage due to improper use.

MONTHLY: Lubricate lock bar pivot bolt and lock bar handle pivot points.

MONTHLY: Lubricate all hinge joints if there are signs of rusting.

SEMI-ANNUALLY: Check fluid level of lift power unit and refill if required. Use only Dexron III ATF or 10wt anti-foam, anti-rust hydraulic oil. If fluid is required, inspect hose and connections and cylinder seals. Repair as required.

Model LFMR6
Installation, Operation, and Maintenance

PARTS BREAKDOWN

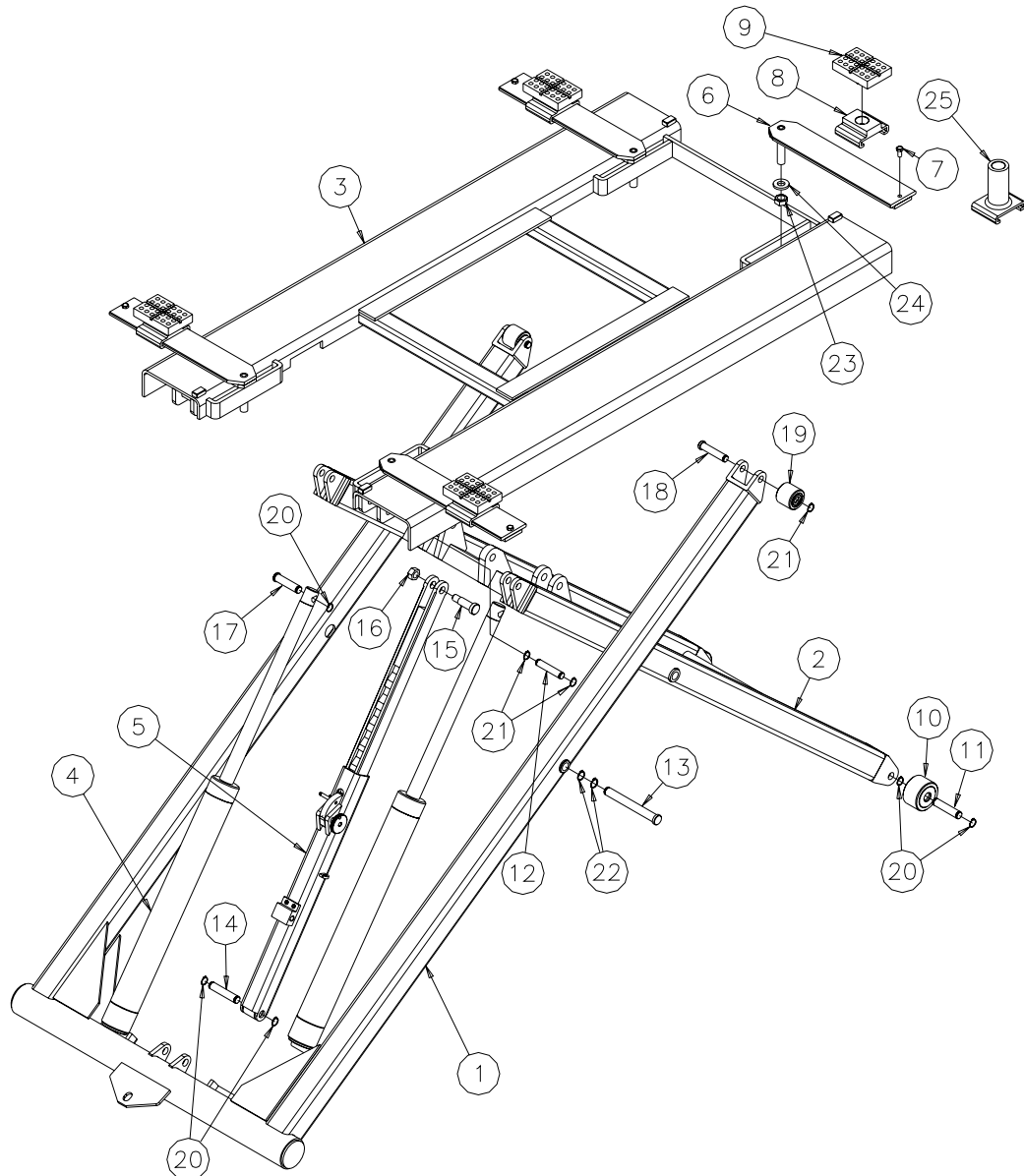

No	Part #	Qty	Description	No	Part #	Qty	Description
1	GTYJ3-01-00	1	Scissor Outside	14	TYJ3-08	1	Safety Locking Pin (Bottom)
2	GTYJ3-03-00	1	Scissor Inside	15	TYJ3-10	1	Safety Locking Pin (Top)
3	GTYJ3-02-00	1	Platform	16	SR-0114	1	Locking Nut, M18
4	GTYJ3-04-00	2	Cylinder Assy.	17	TYJ3-09	2	Cylinder Pin
5	GTYJ3-07-00	1	Safety Locking Assy.	18	TYJ3-15	2	Wheel Pin (Small)
6	TYJ3-05-03	4	Plate	19	TYJ3-14-00	2	Wheel (Small)
7	WBM1015	4	Bolt, M10x16	20	GB896-86	6	Retaining Pin 20
8	TYJ3-05-02	4	Saddle Holder	21	GB894.1-86	6	Retaining Pin 18
9	TYJ3-05-01	4	Rubber Saddle	22	GB894.1-86	4	Retaining Pin 24
10	TYJ3-11-00	2	Wheel (Big)	23	S240380	4	Nut, M20
11	TYJ3-12	2	Wheel Pin (Big)	24	X10-099	4	Washer, M20
12	TYJ3-16	2	Connecting Pin	25	TYJ3-05-02G	4	6 7/8" Extensions
13	TYJ3-13	2	Scissor Pin				

Model LFMR6
Installation, Operation, and Maintenance
SAFETY LOCK ASSEMBLY

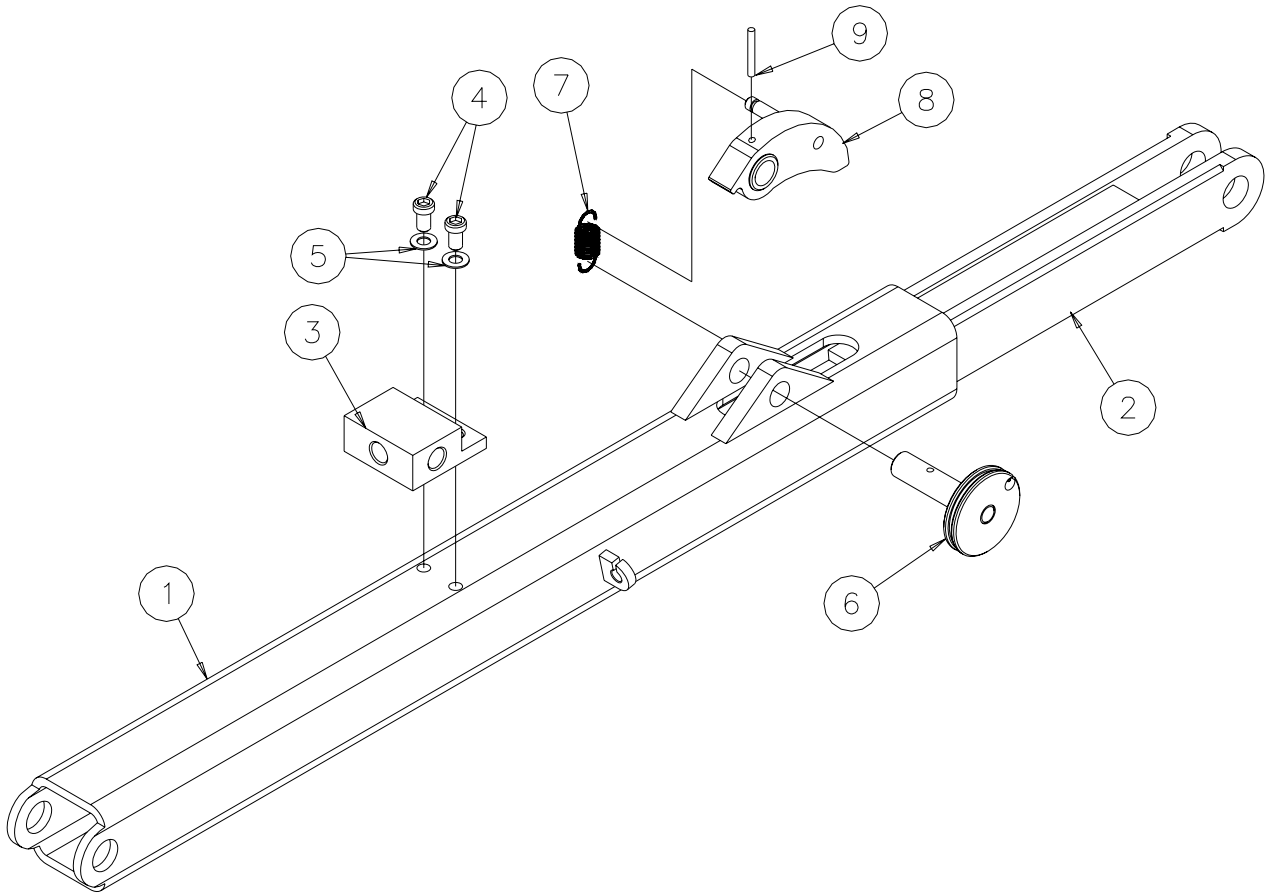

No.	Part #	Qty.	Description
1	GTYJ3-07-02	1	Lock Sheath
2	GTYJ3-07-01	1	Lock Pole
3	TYJ3-07-05	1	Base
4	S251397	2	Bolt, M8
5	SR-0112	2	Washer, M8
6	TYJ3-07-04	1	Pulley Assy.
7	TYJ3-07-06	1	Spring
8	TYJ3-07-03	1	Lock Block
9	GB879-86	1	Pin

Model LFMR6
 Installation, Operation, and Maintenance
POWER UNIT STAND / TOW DOLLY
ASSEMBLY INSTRUCTIONS

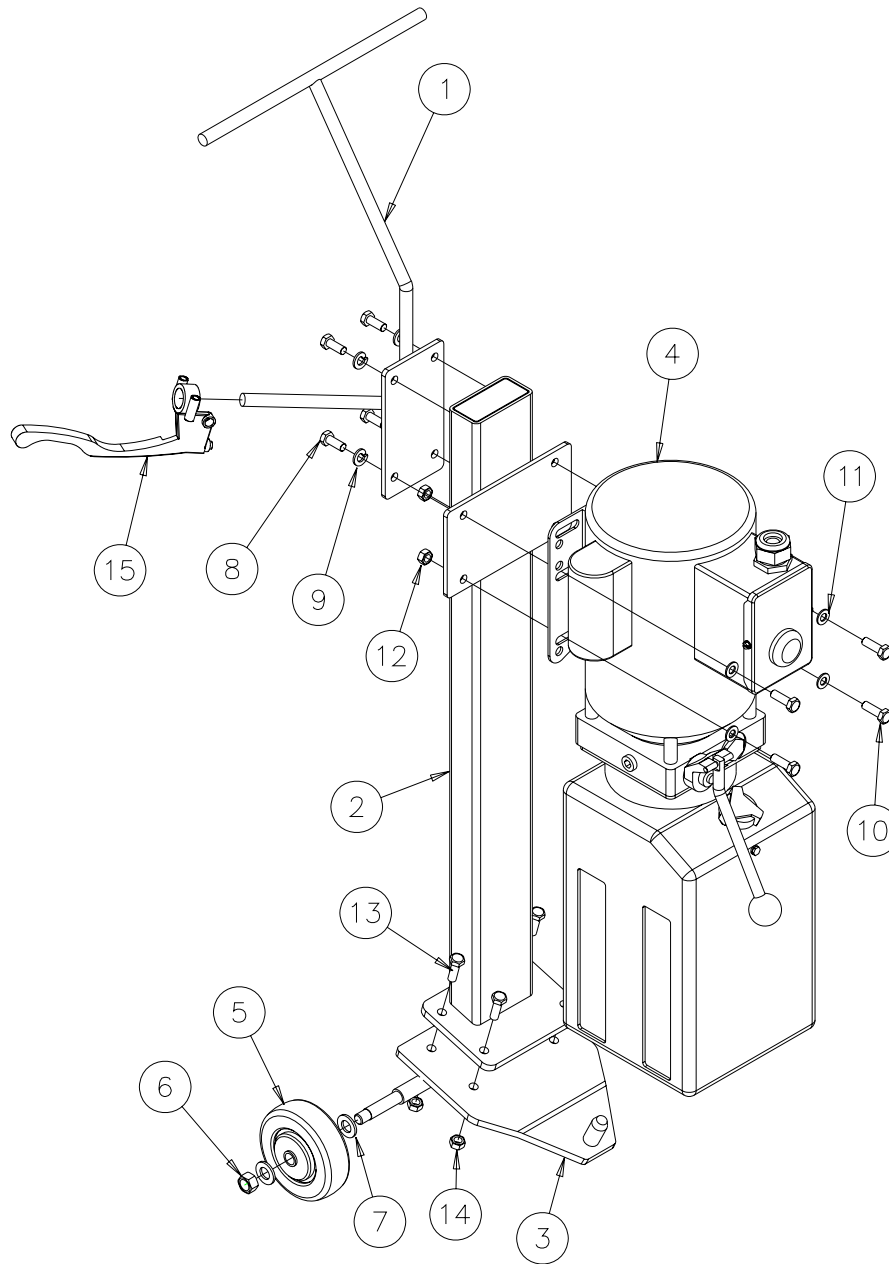

No.	Part #	Qty.	Description	No.	Part #	Qty.	Description
1	TYJ3-00-01-1	1	Handle	9	ZVS1882	4	Lock Washer, M8
2	TYJ3-00-01-2-1	1	Stand	10	S251401	4	Bolt, M8x25
3	TYJ3-00-01-2	1	Base	11	SR-0112	4	Washer, M8
4	AB-1653-B	1	Electric/Hyd. Unit	12	X10-040	4	Nut, M8
5	TYJ3-00-01-3	2	Wheel	13	4100342	4	Bolt, 5/16"-18 x 1/2"
6	X10-040	2	Nut, M12	14	4100237	4	Nut, 5/16"-18
7	Z10-038	4	Washer, M12	15	TYJ3-32	1	Lock Release Handle
8	S252903	4	Bolt, M8x20				

Model LFMR6
 Installation, Operation, and Maintenance

HYDRAULIC/LOCK RELEASE BREAKDOWN

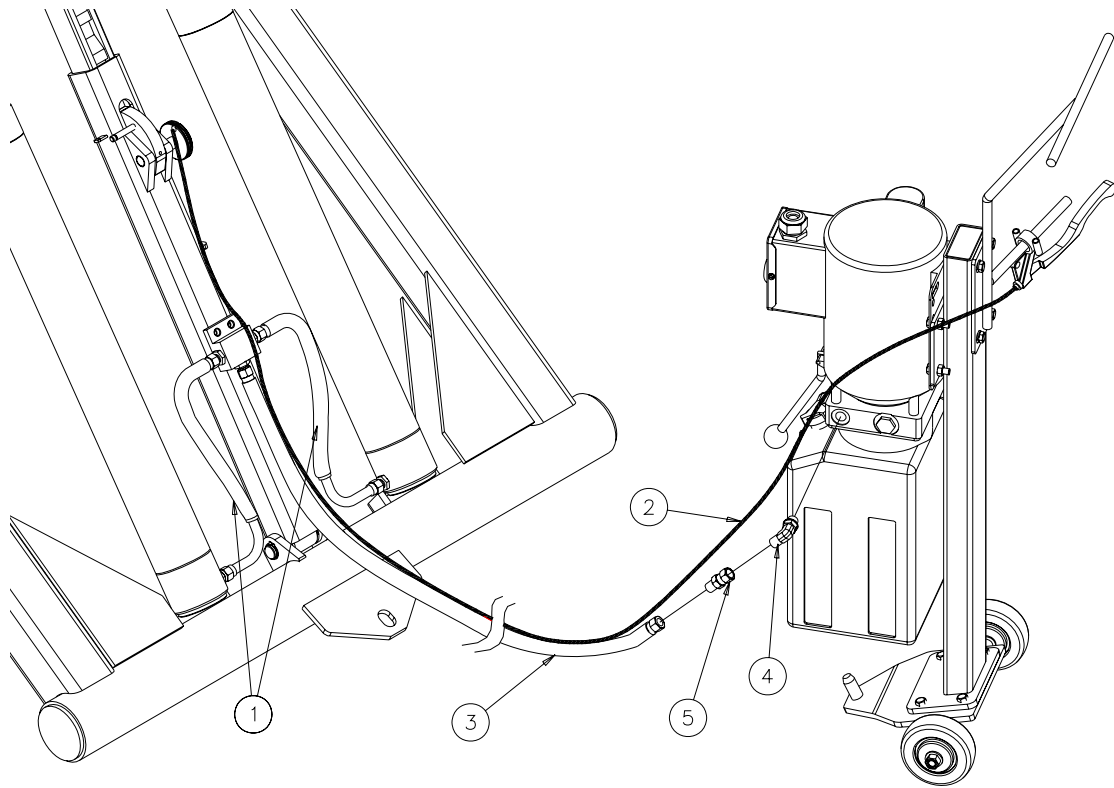

No	Part #	Qty.	Description
1	TYJ3-25	2	Hydraulic Hose Short
2	TYJ3-31	1	Lock Release Cable
3	TYJ3-26	1	Hydraulic Hose Long
4	16167	1	Hyd. Elbow; 9/16-18 O-Ring x 37 deg Male
5	66020	1	1/4 NPTM x #6 JIC 37 deg Female