

# Priority Based Conveyor Feeding System with IOT

F.Zumyla Shanaz<sup>1</sup>, Bala Karthika G, Hari Preetha S, Hari Priya J, Jayahari Krishna SA<sup>2</sup>,

<sup>1</sup> Assistant Professor, Dept. of ECE, Sri Shakthi Institute of Engg and Tech, Coimbatore

<sup>2</sup> Final Year ECE Students, Sri Shakthi Institute of Engg and Tech, Coimbatore.

(E-mail: [zumylashanaz@siet.ac.in](mailto:zumylashanaz@siet.ac.in) )

**Abstract**— This feeder system based on priority is a simple conveyor feeder system which has Master Hopper feeder as source. Conveyor is feeding materials for two machines which will be processed and is used for its production. Since those machines doesn't has material demand always we are planning this feeder system efficient manner by supplying materials to two machines simultaneously based on its demand. To know the machines supply demand we have sensor in both machines and also has no demand sensors. If a machine had demand we switch on the conveyor and feed the machine until no demand signals come. If both the machines has supply demand we have priority calculations and based on demand priority we feed the machine by switching on conveyor in forward and reverse direction. This conveyor system has main hopper feeder which also has full level and empty level sensors. If conveyor is switching of hopper feeder valve is opened to supply materials to conveyor. If hopper is empty whole system is stopped and alert lamp and buzzer is switched on until hopper is full. Here we are proposing Internet of Things (IoT) concept to monitor the whole function of feeder system remotely using a Computer or Mobile Phone. Raspberry Pi board is used as master controller and all the information from sensors are updated online..

**Keywords**— *feeder system; Conveyor; Raspberry Pi; Internet of Things; Mobile Phone; sensor.*

## I. INTRODUCTION

IOT or Internet things refer to the network of connected physical objects that can intervention. It has been formally defined as an "Infrastructure of Information Society" because IoT sanctions us to mass information from all kind of mediums such as humans, animals, conveyances, kitchen appliances. Thus, any object in the physical world which can be provided with an IP address to enable data transmission over a network can be made part IoT system by embedding them with electronic hardware such as sensors, software and networking gear. IoT is different than internet as in a way it transcends Internet connectivity by enabling everyday objects that utilizes embedded circuits to interact and communicate with each other utilizing the current internet infrastructure.

Since then the scope of IoT has grown tremendously as current it consists of more than 12 billion connected devices and according to the experts it will increase to 50 billion by the end of 2020. With the advent of IoT both manufacturers and consumers have benefited. Manufacturers have gained insight into how their products are used and how they perform out in the real world and increase their revenues by providing value added services which enhances and elongates the life cycle of their products or services. Consumers on the other hand have the ability to integrate and control more than one device for a more customized and improved user experience. Embedded system is a combination of hardware and software use to achieve a single task within a given time frame, repeatedly and endlessly, with or without human interactions. Embedded system of a computer system than monitor, respond to control an external environment. Environment connected to a system through sensors, actuators and other input output interfaces. Embedded system must meet timing and other constraints imposed on it by environment. An embedded system in general incorporates hardware operating system and peripheral devices and communication software to enable to perform the predefined functions. As Automation need is increasing day by day so many innovations are introduced into the industries and market on daily basis. So to be a leader in market every company need a R&D division and to introduce new innovation in their existing products or to introduce new products. Here we proposed a feeder system based on priority. This is a simple conveyor feeder system which has master Hopper feeder as source. Conveyor is feeding materials for two machines which will be processed and is used for its production.

Since those machines doesn't has material demand always we are planning this feeder system efficient manner by supplying materials to two machines simultaneously based on its demand. To know the machines supply demand we have sensor in both machines and also has no demand sensors. If a machine had demand we switch on the conveyor and feed the machine until no demand signals come. If both the machines has supply demand we have priority calculations and based on demand priority we feed the machine by switching on conveyor in forward and reverse direction. This conveyor system has main hopper feeder which also has full level and

empty level sensors. If conveyor is switching of hopper feeder valve is opened to supply materials to conveyor. If hopper is empty whole system is stopped and alert lamp and buzzer is switched on until hopper is filled. Here we are proposing Internet of Things (IoT) concept to monitor the whole function of feeder system remotely using a Computer or Mobile Phone. Raspberry Pi board is used as master controller and all the information from sensors are updated online..

## II. EXISTING SYSTEM

In this manual mode conveyor control system, manual zero speed module is only available. It has the facility to operate conveyor without proper control system. In this system, before starting conveyor system, it is necessary to start the receiving conveyor and then start the feeding conveyor i.e. operating logic is from downstream to upstream. For stopping the conveyor system, the operation will be just the opposite i.e. from upstream to downstream. So it is necessary, if any receiving conveyor is stopped in the system, all the upstream conveyor should stop automatically. If due to any problem, the rotation of conveyor becomes slow or towards zero it is necessary to stop the conveyor. This is known as manual zero speed protection Electronic intelligent conveyor control technology is useful for complex conveying tasks. The modern electronic intelligent conveyor control system using new generation microcontroller is to be designed for overcoming the limitations of existing systems. The boiler is fed with lignite at four points and each point is driven by motor. Three feeders and one transport conveyor are used to feed the lignite to the boiler. The various modules like zero speed module, chain positioned module, no flow module and speed transmitter module are involved in each feeder. [1]. Screw conveyors are systems that convey and meter the flow of dry particulate solids. In principle, they are based on the Archimedeian principle of conveying; relying on the friction between the materials and the rotating screw or its housing in order to continuously transport materials from the inlet to the outlet . The advantages of screw conveyors are compact and versatile design, easy installation and low maintenance. On the other hand, they are limited to low volume and non-abrasive materials. They are mainly composed of six parts: a helical screw, an actuator with a driving shaft, a shaft coupling, a U-trough or pipe shaped screw housing, a hopper, and a material outlet. Such systems find applications over a wide range of mass size, from as small as granular or powder in pharmaceutical and food processing industries to as big as rocks in mining, construction and agricultural industries.

In order to obtain a precise material feeding rate, accurate mass measurements are required. Mass flow estimate computed based on weight measurements is commonly known as gravimetric feeding. Weight measurement in gravimetric feeding mechanism is prone to vibrations caused by unbalanced feeder or screw/actuator misalignment as well as

surrounding equipment. In , capacitive sensing is utilized to obtain an accurate rotational speed and material fill level measurements. However, proper signal processing is required. [2]. As combined mining technology has been applied much widely in coal mine, the daily output from mining face has also increased greatly, and hence belt conveyor with long distance and huge traffic becomes one of the main delivery equipment in coal mine. Now, the safety and reliability of such conveyor is very important in mine production. However, due to the complexity of production conditions, centralized belt conveyor in many coal mines has to suffer such problems as impact of big gangue and uneven loads on the belt during the process of coal feeding, thus probably leads to decrease the strength of belt, in worse to destroy the driving motor or break the belt, which means great loss in economy and safety. To solve such problems, this paper, on the background of the production conditions of Shuguang Coal Mine, designs an auto control system based on armored belt feeder and Programmable Logic Controller (PLC).

The successful design of multi-loading control system for centralized belt conveyor, will ensure the transport system in mine to run more safely and reliably with high efficiency and economy. It will help staff in mine make better administration and will be very important in increasing the production efficiency [3].

## III. PROPOSED SYSTEM

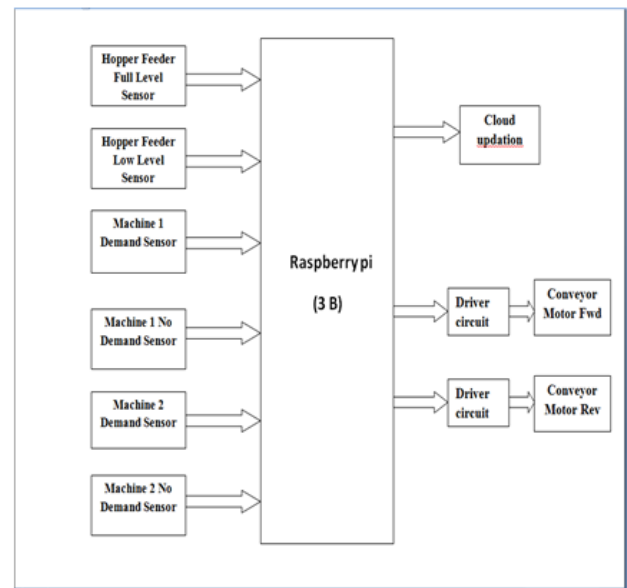

Figure 1; Block diagram of conveyor feeder system

Here the block diagram explains the schematic explanation of the system. It contains two bins attached with High level sensor as well as low level sensor. There is a main hopper feeder with high level sensor and low level sensor. If the high level sensor does not detect any object, it indicates that the

main hopper is in search of demand. As soon as the main hopper shows demand, it is filled with the products manually or automatically.

There is a single motor connected to both sensors of the bins. According to the priority of the demand, the motor runs in both forward and reverse direction to match the demand. The motor control is connected to the driver circuit or relay circuit.

All the data from the sensors are updated in the cloud. The cloud update is carried through cayenne mobile application or software. This is possible only by connecting the system and mobile through same network. This uses MQTT protocol for the information transfer and updating in cloud.

#### A. Power Supply

The power supply is very important section of all electronic devices as all the electronic devices works only in DC. One important aspect of the project is that the power supply should be compact. Most electronic devices need a source of DC power. The circuit is powered by a 12V dc adapter, which is given to LM7805 voltage regulator by means of a forward voltage regulator by means of a forward voltage protection diode and is decoupled by means of a 0.1 uf capacitor. The voltage regulator gives an output of exactly 5V dc supply. The 5V dc supply is given to all the components including motor, IR sensors, driver circuit. The AC supply which when fed to the step down transformer is leveled down to 12 volts AC. This is then fed to full wave rectifier which converts it into 12 volts DC. This is then passed to a filter to remove the ripples. Then it is fed to a voltage regulator that converts 12V to 5V stable voltages and currents.

A regulator circuit removes the ripples and also remains the same dc value even if the input dc voltage varies, or the load connected to the output dc voltage changes. The voltage regulation is usually obtained using one of the popular voltage regulator IC units.

#### B. Relay

A relay is an electrically operated switch. Electric current through the coil of the relay creates a magnetic field which attracts a lever and changes the switch contacts. The coil current can be on or off so relays have two switch positions and there are double-throw (changeover) switches. It consists of a coil of wire surrounding a soft iron core, an iron yoke, which provides a low reluctance path for magnetic flux, a movable iron armature, and a set, or sets, of contacts. In this condition, one of the two sets of contacts in the relay pictured is closed, and the other set is open. The P0\_0, P0\_1, P0\_2 and P0\_3 pin of controller is assumed as data transmit pins to the relay through relay driver ULN 2003.

#### C. IR Sensor

Infra-red sensors are the most often used sensor by amateur roboteers. Understanding how they behave can help address many of your requirements and would suffice to address most of the problem statements for various robotics events in India. Be it a typical white/black line follower, a wall follower, obstacle avoidance, micro mouse, an advanced flavor of line follower like red line follower, etc., all of these problem statements can be easily addressed and granular control can be exercised upon your robots performance if you have a good operational understanding of Infra-red sensors.

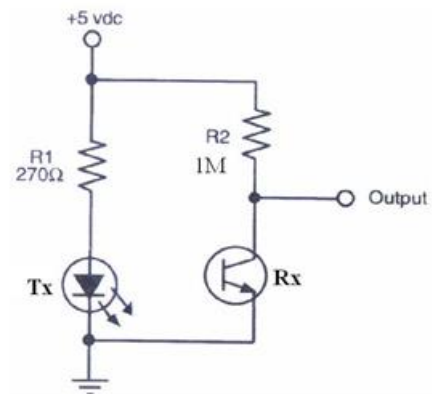

Figure 2; Infrared Sensor Circuit

Infra-red sensors are in the form of diodes with 2 terminals. You can buy a pair of such diode (one transmitter and one receiver) at a very low cost of about 5 - 7 rupees only. Here onwards, we will use Tx to refer to a transmitter and Rx to refer to a receiver diode. Upon careful observation, you will notice that amongst the two 'legs', one has a much wider base within the diode. That is normally the cathode (negative) whereas the leg having a smaller base would be the anode (positive terminal). When the Tx is forward biased, it begins emitting infra red. Since it's not in visible spectrum, you will not be able to see it through naked eyes but you will be able to view it through an ordinary cell phone camera. The resistance R1 in the above circuit can vary. It should not be a very high value (~ 1Kohm) as then the current flowing through the diode would be very less and hence the intensity of emitted IR would be lesser. By increasing the current flowing in the circuit, you can increase the effective distance of your IR sensor. However, there are drawbacks of reducing the resistance. Firstly, it would increase the current consumption of your circuit and hence drain the battery (one of the few 'precious' resources for any embedded system) faster. Secondly, increasing the current might destroy the Tx. So, the final choice should be a calculated tradeoff between these various factors.

To achieve better distance and immunity IR can be modulated. The receiver diode has a very high resistance, typically of the order of mega Ohms when IR is not incident upon it. However, when IR is incident upon it, the resistance decreases sharply to the order of a few kilo Ohms or even lesser. This feature forms

the basis of using IR as a sensor. You will need to connect a resistance of the order of a few mega Ohm in series with the Rx. Then tap the output voltage at the point of connectivity of these two resistors.

**D. IR Transmitter**

Infrared transmitter is a light emitting diode (LED which emits infrared radiations. Hence, they are called IR LED's. Even through an IR LED looks like a normal LED, the radiation emitted by it is invisible to the human eye. The picture of a typical infrared Led is show below. There are different types of infrared transmitters depending on their wavelengths, output power and respond time. A simple infrared transmitter can be constructed using an infrared LED, a current limiting resistor and a power supply .The schematic of a typical IR transmitter is shown below;

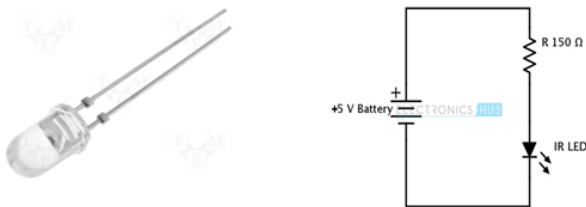

Figure 3; IR transmitter and circuit

**E. IR Receiver**

Infrared receivers are also called as infrared sensors as they detect the radiation from an IR transmitter. IR receivers come in the form of photodiodes and phototransistors. Infrared photodiodes are different from normal photo diodes as they detect only infrared radiation. Different types of IR receivers exists based on the wavelength, voltage, package, etc. When used in an infrared transmitter

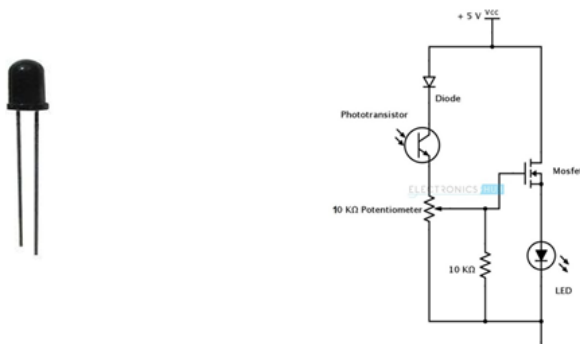

Figure 4 ; IR Receiver and circuit

**F. Obstacle Sensing Circuit or IR Sensor Circuit**

It consists of an IR LED, a photodiode, a potentiometer, an IC Operational amplifier and an LED. IR LED emits infrared light. The Photodiode detects the infrared light. An IC Op – Amp is used as a voltage comparator. The potentiometer is used to calibrate to output of the sensor

according to the requirement. When the light emitted by the IR LED is incident on the photodiode after hitting an object, the resistance of the photodiode falls down from a huge value. One of the input of the op – amp is at threshold value set by the potentiometer. The other input to the op-amp is from the photodiode's series resistor. When the incident radiation is more on the photodiode, the voltage drop across the series resistor will be high. In the IC, both the threshold voltage and the voltage across the series resistor are compared. If the voltage across the resistor series to photodiode is greater than that of the threshold voltage, the output of the IC Op – Amp is high. As the output of the IC is connected to an LED, it lightens up. The threshold voltage can be adjusted by adjusting the potentiometer depending on the environmental conditions. The positioning of the IR LED and the IR Receiver is an important factor. When the IR LED is held directly in front of the IR receiver, this setup is called Direct Incidence. In this case, almost the entire radiation from the IR LED will fall on the IR receiver. Hence there is a line of sight communication between the infrared transmitter and the receiver. If an object falls in this line, it obstructs the radiation from reaching the receiver either by reflecting the radiation or absorbing the radiation.

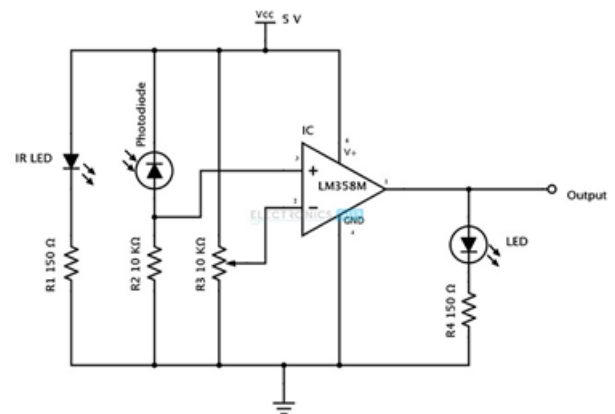

Figure 5; Obstacle Sensing Circuit

**G. Motor Control**

DC Motors are electromechanical devices which use the interaction of magnetic fields and conductors to convert the electrical energy into rotary mechanical energy. The DC motor achieves this by producing a continuous angular rotation that can be used to rotate pumps, fans, compressors, wheels, etc.

As well as conventional rotary DC motors, linear motors are also available which are capable of producing a continuous linear movement. There are basically three types of conventional electrical motor available: AC type Motors, DC type Motors and Stepper Motors.

Normal DC motors have almost linear characteristics with their speed of rotation being determined by the applied DC

voltage and their output torque being determined by the current flowing through the motor windings. The speed of rotation of any DC motor can be varied from a few revolutions per minute (rpm) to many thousands of revolutions per minute making them suitable for electronic, automotive or robotic applications. By connecting them to gearboxes or gear-trains.

#### H. DC motor

A DC motor is designed to run on DC electric power. Two examples of pure DC designs are Michael Faraday's homopolar motor (which is uncommon), and the ball bearing motor, which is (so far) a novelty. By far the most common DC motor types are the brushed and brushless types, which use internal and external commutation respectively to create an oscillating AC current from the DC source—so they are not purely DC machines in a strict sense. In our project are using brushed DC Motor, which will operate in the ratings of 12V DC 0.6A which will drive the flywheels in order to make the robot move.

#### I. Raspberry Pi

The Raspberry Pi 3 Model B+ is the latest product in the Raspberry Pi 3 range, boasting a 64-bit quad core processor running at 1.4GHz, dual-band 2.4GHz and 5GHz wireless LAN, Bluetooth 4.2/BLE, faster Ethernet, and PoE capability via a separate PoE HAT The dual-band wireless LAN comes with modular compliance certification, allowing the board to be designed into end products with significantly reduced wireless LAN compliance testing, improving both cost and time to market. The Raspberry Pi 3 Model B+ maintains the same mechanical footprint as both the Raspberry Pi 2 Model B and the Raspberry Pi 3 Model B. 2 Raspberry Pi 3 Model B+ BCM2837B0, Cortex-A53 64-bit SoC @ 1.4GHz 1GB LPDDR2 SDRAM 2.4GHz and 5GHz IEEE 802.11.b/g/n/ac wireless LAN, Bluetooth 4.2, BLE Gigabit Ethernet over USB 2.0 (maximum throughput 300Mbps) 4 × USB 2.0 ports Extended 40-pin GPIO header 1 × full size HDMI MIPI DSI display port MIPI CSI camera port 4 pole stereo output and composite video port H.264, MPEG-4 decode (1080p30); H.264 encode (1080p30);

### IV. SOFTWARE REQUIREMENT

#### IOT

The Internet of things (IoT) is the network of physical devices, vehicles, home appliances, and other embedded with electronics, software, sensors, actuators, and network connectivity which enable these object to connect and exchange data. Each thing is uniquely identifiable through its embedded computing system but is able to inter-operate within the existing Internet infrastructure. Experts estimate that the IoT will consist of about 30 billion object by 2020.

The IoT allows object to be sensed or controlled remotely across existing network infrastructure, creating opportunities for more direct integration of the physical world into computer-based system, and resulting in improved efficiency, accuracy and economic benefit in addition to reduced human intervention. When IoT is augmented with sensors and actuators, the technology becomes an instance of the more general class of cyber-physical system, which also encompasses technologies such as smart grids, virtual power plant, smart homes, intelligent transportation and smart cities.

#### Applications

##### Consumer applications

A growing portion of IoT devices are created for consumer use, including connected vehicles, home automation, wearable technology (as part of Internet of Wearable Things), connected health, and appliances with remote monitoring capabilities.

##### Commercial application

The Internet of Medical Things (also called the internet of health things) is an application of the IoT for medical and health related purposes, data collection and analysis for research, and monitoring. This 'Smart Healthcare as it can also be called led to the creation of a digitized healthcare system, connecting available medical resources and healthcare services.

IoT devices can be used to enable remote health monitoring and emergency notification systems. The IoT can assist in the integration of communications, control, and information processing across various transportation systems. Application of the IoT extends to all aspects of transportation systems (i.e. the vehicle, he infrastructure, and the driver or user). Dynamic interaction between these components of a transport system enables inter and intra vehicular communication, smart traffic control, smart parking, electronic toll collection systems, logistic and fleet management, vehicle control, and safety and road assistance.

##### Industrial Applications

The IoT can realize the seamless integration of various manufacturing devices equipped with sensing, identification, processing, communication, actuation, and networking capabilities. Based on such a highly integrated smart cyber physical space, it opens the door to create whole new business and market opportunities for manufacturing. Network control and management of manufacturing equipment, asset and situation management, or manufacturing process control bring the IoT within the realm of industrial applications and smart manufacturing as well. The IoT intelligent systems enable rapid manufacturing of new products, dynamic response to product demands, and real-time optimization of manufacturing production and supply chain networks, by networking machinery, sensors and control systems together.



There are numerous IoT applications in farming such as collecting data on temperature, rainfall, humidity, wind speed, pest infestation, and soil content. This data can be used to automate farming techniques, take informed decisions to improve quality and quantity, minimize risk and waste, and reduce effort required to manage crops. For example, farmers can now monitor soil temperature and moisture from afar, and even apply IoT-acquired data to precision fertilization programs.

### HTML

HTML or Hypertext Markup Language, is used by web programmers to describe the contents of a web page. It is not programming language. You simply use HTML to indicate what a certain chunk of text is—such as a paragraph, a heading or specially formatted text. All HTML directives are specified using matched sets of angle brackets and are usually called tags.

### Web Browsers

The purpose of a web browser (chrome, IE, Firefox, safari) is to read HTML documents and display them. The browser does not display the HTML tags, but uses them to determine how to display the documents.

### PHP

PHP is a server side scripting language designed for web development but also used as a general purpose programming language. As of January 2013, PHP was installed on more than 240 million websites (39% of those sampled) and 2.1 million web servers. Originally created by Ramus Leadoff in 1994, the reference implementation of PHP (powered by Zend engine) is now produced by the PHP group, while PHP originally stood for personal home page, it now stands for PHP: hypertext preprocessor, which is a recursive backronym. PHP code can be simply mixed with html code, or it can be used in combination with various templating engines and web frameworks. PHP code is usually processed by a PHP interpreter, which is usually implemented as a web server's native module or a common gateway interface (cgi) executable. After the PHP code is interpreted and executed, the web server sends the resulting output to its client, usually in the form of a part of the generated web page; for example, PHP code can generate a webpage's html code, an image or some other data. PHP has also evolved to include a command-line interface (cli) capability and can be used in standalone graphical applications. The standard PHP interpreter, powered by the zend engine, is free software released under the PHP license. PHP has been widely ported and can be deployed on most web services on almost every operating system and platform, free of charge.

## V. EXPERIMENTAL RESULTS

### HARDWARE

The hardware includes sensor circuit, driver circuit and the control. This feeder system based on priority is a simple conveyor feeder system which has Master Hopper feeder as source. Conveyor is feeding materials for two machines which will be processed and is used for its production. Since those machines don't have material demand always we are planning this feeder system efficient manner by supplying materials to two machines simultaneously based on its demand. To know the machines supply demand we have sensor in both machines and also has no demand sensors. If a machine had demand we switch on the conveyor and feed the machine until no demand signals come. If both the machines have supply demand we have priority calculations and based on demand priority we feed the machine by switching on conveyor in forward and reverse direction. This conveyor system has main hopper feeder which also has full level and empty level sensors. If conveyor is switching of hopper feeder valve is opened to supply materials to conveyor. If hopper is empty whole system is stopped and alert lamp and buzzer is switched on until hopper is full.

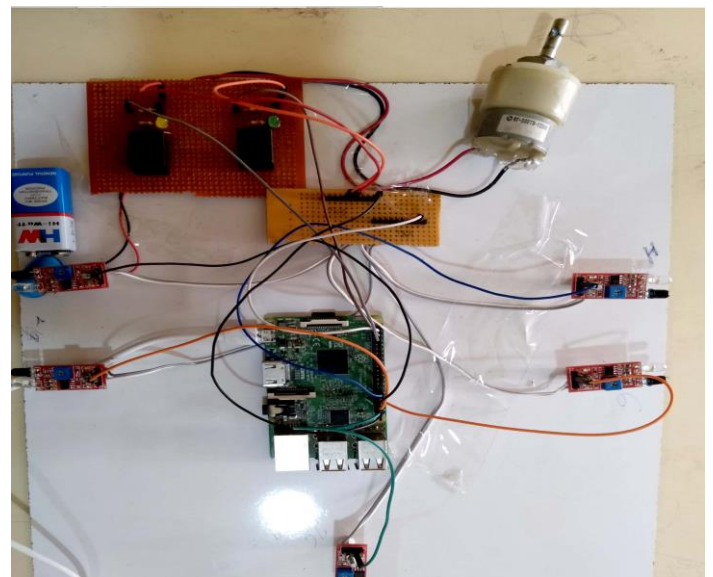

Figure 6; Hardware Kit

Here we are proposing Internet of Things (IoT) concept to monitor the whole function of feeder system remotely using a Computer or Mobile Phone. Raspberry Pi board is used as master controller and all the information from sensors are updated online. This advanced automated conveyor system eliminates the manpower and improves the monitoring process in remote areas. By implementing this project we can able to calculate the priority of two bins and to supply the products simultaneously.

Cayenne is an app for smart phones and computers that allows you to control the Raspberry Pi and soon also the Arduino through the use of an elegant graphical interface and a solid nice communication protocol.

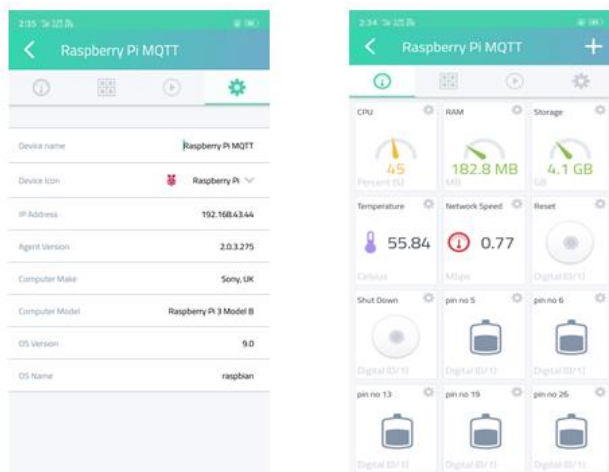

Figure 7 ; Cayenne IOT Inspections

## VI. CONCLUSION AND FUTURE SCOPE

The development of priority based conveyor feeding system will be very useful and it helps in better way in enhancing the feeding process. The IOT technique used is an modern technology and gives a good solution for monitoring which reduces the man power required. It is also helpful for continuously monitoring the parameters based on priority calculation and updates in cloud. The IOT technology helps to monitor the updates from anywhere in the globe which is the main intention of this project. This automatic feeder system technology reduces the need of man power that it is not necessary that we have to be near the machine to feed them which will save time. It is a stable mechanism and the sensed

values are stored in the cloud and the messages are sent to the user which indicates the process is done. With the continuous monitoring of the machine parameters we will be able to avoid the unexpected damages and can increase the machine's lifetime. It is a cost effective and thus monitoring the machine to improve the production

## ACKNOWLEDGMENT

The authors wish to thank Head of the department ECE and management of Sri Shakthi Institute of Engineering and Technology Coimbatore for his support throughout completion of this project.

## REFERENCES

- [1] R.Manochitra, S.Charles Raja," Modernization of lignite feeder control system using microcontroller with multidrop mode", International Conference on Circuit, Power and Computing Technologies, Jun 2015
- [2] Ambedkar.A.G, Mechanism of Machine Theory, prentice hall of India New Delhi,2007
- [3] Sclater Neil, "Chain and Belt Devices and Mechanisms",Mechanisms and mechanical devices source book, 5th Edition,2011
- [4] Thomasbevan,"Theory of Machines",CBS publisher and Distributor,1984
- [5] Burghardt, henry D, "Machine Tool Operation",. McGraw-Hill,1922
- [6] Vaziri.M, Brojeni.F, Shulman.E, Thakur, "Innovative Distribution Feeder Protection and Control Schemes Using New Capabilities of Microprocessor Relays," Published in 59th Annual conference, 2006
- [7] Technical paper on "An intelligent conveyor control system for coal handling plant" of thermal power station by Makarand Joshi in Plant Maintenance Resource Center