

Specifications				(The wire rope composition is a manufacturer recommendation.)	
Load Rating	980N (= 100kgf)	Handle Force	Handle Length	Number of Wire Rope Winding Layer	
Wire Rope Tension	4th Layer (Standard Layer)		250mm	Wire Rope Tension	1st Layer 143N (= 14.6kgf)
Drum Capacity	Wire Rope 6-Layer Windings φ 5mm (6 × 19) × 35m	Standard Accessories		One Handle	
Gear Ratio	1/1	Painting		One Hex Wrench for Anchoring the Wire Rope	
Effective Handle Length	250mm (Maximum)			Melamine Resin Coating At Two Layers	
Weight	8.1kg (Winch + Handle)			Painting Color Drum : Black (Munsell N1 Semi Gloss) Others : Munsell 7.5YR6/11	

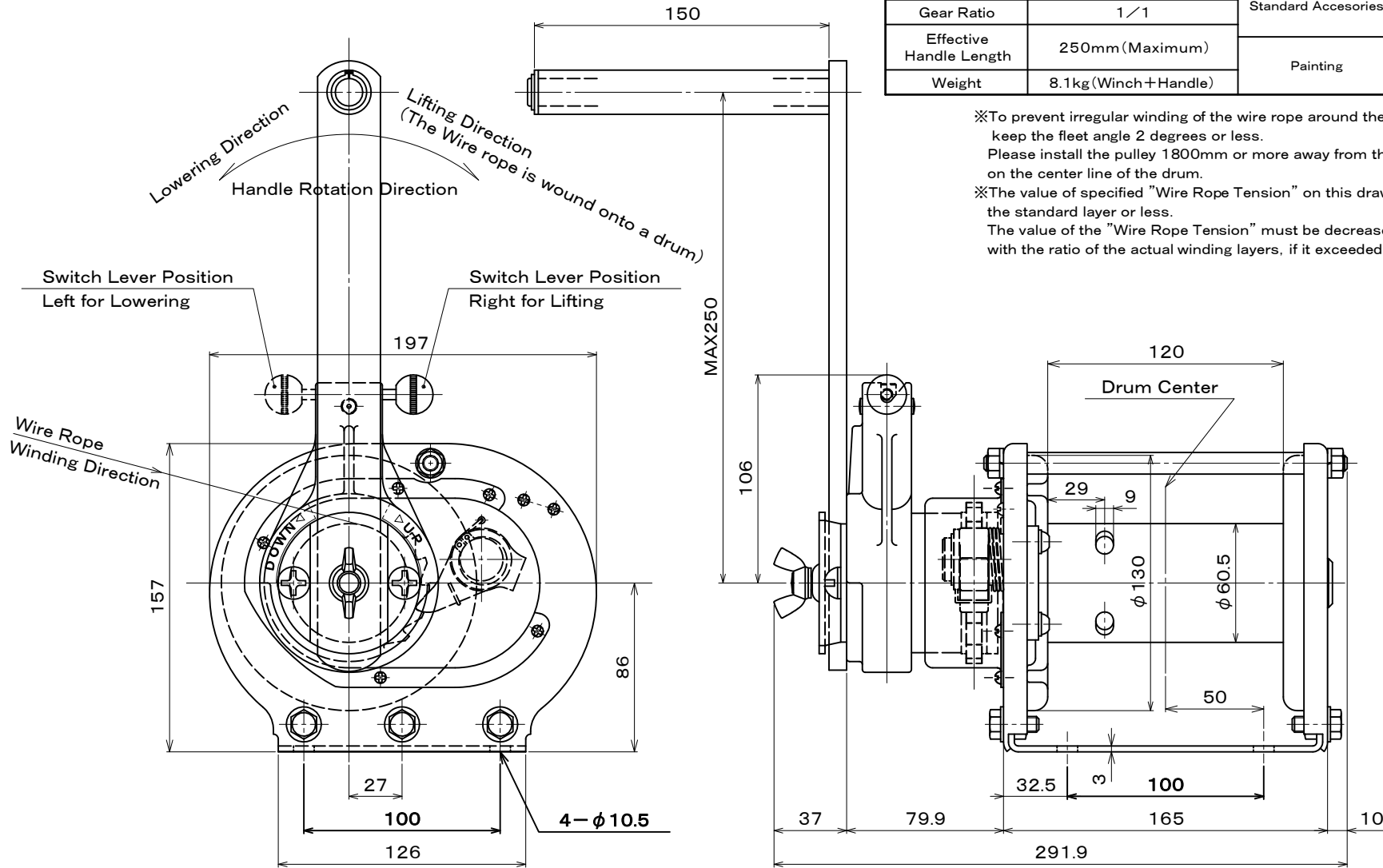

※To prevent irregular winding of the wire rope around the drum, keep the fleet angle 2 degrees or less. Please install the pulley 1800mm or more away from the drum on the center line of the drum.

※The value of specified "Wire Rope Tension" on this drawing is for the standard layer or less. The value of the "Wire Rope Tension" must be decreased accordance with the ratio of the actual winding layers, if it exceeded.

△ ×			図面番号 / DRAWING No.	MR1SI-160804-01E	改訂番号 / REVISION No.	00	お客様 / CUSTOMER		符号 / MARK	項目 / PARTICULARS	材料 / MATERIAL	数量 / QTY	単体 / 合計 / PER ONE / TOTAL	備考 / REMARKS
△ ×			承認 / APPROVED	検図 / CHECKED	作成 / DRAWN	図面名 / TITLE			第三角法 / THIRD ANGLE PROJECTION					
△ ×			設計部	設計部	設計部	MAXPULL WINCH STOPPER ARMLESS RATCHET TYPE MODEL MR-1-SI			尺度 / SCALE	台数 / QTY				
△ ×			'16.08.04	'16.08.04	'16.08.04									
改訂 / REVISION			米澤	松嶺	武松									

