

AUTO CAL II

PO Box 10083 Sta. 1
233 Safety Road
Houma, LA 70363
Tel # 985-868-1477 Fax # 985-879-1617
email - autocalflow@aol.com
www.autocalflow.com

Operating Instructions

Metric System

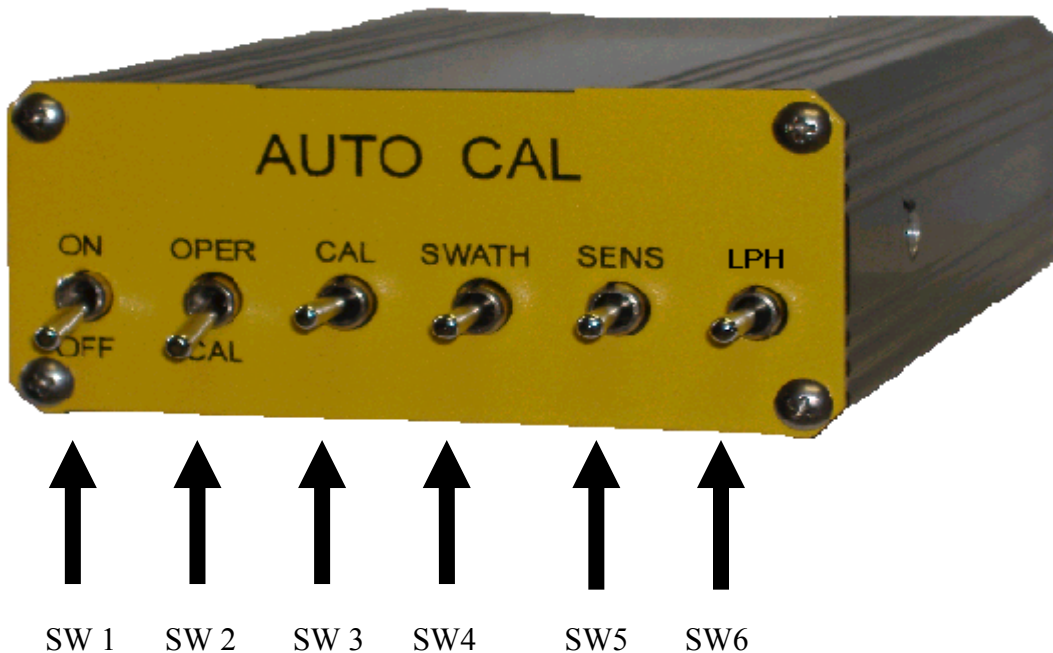

Switch 1 – Power on and power off.

Switch 2 – Sets computer in operation or calibration mode.

Switch 3 – (a) Sets calibration code when switch 2 is in Cal position.
(b) Extends or retracts servo when switch 2 is in Cal position.
This feature is used during maintenance or emergency and can not be used for spraying.

Switch 4 – Sets desired swath width.

Switch 5 – Sets sensitivity of system.

Switch 6 – Sets desired rate.

Display

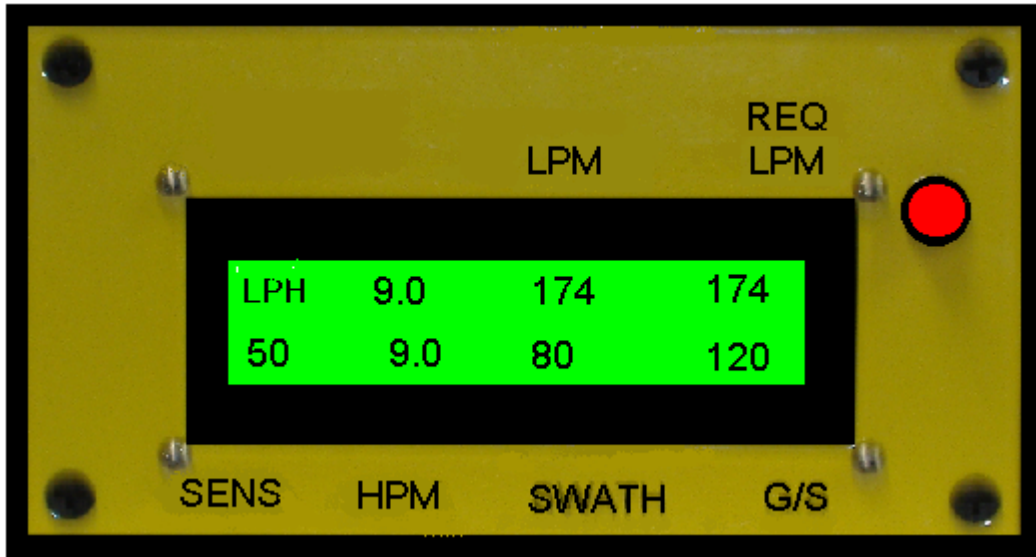

Height 6.35 cm – Width 11.4 cm – Depth 2.79 cm – Weight .1361 kg

1. LPH – Liters per hectare desired.
2. LPM – Liters per minute being pumped through booms.
3. REQ LPM – Liters per minute required at your current speed. Auto Cal II will automatically and continuously adjust flow to match REQ LPM when spray system is on. Upwind, downwind, heavy or light aircraft, Auto Cal II will maintain your selected rate per hectare.
4. SENS – This setting controls the sensitivity of the actuator or other controllers. It controls the minimum movement. Settings to high will cause boom pressure fluctuations.

General Guidelines

- a. 20 is the maximum setting for servo. 100 for hydraulic or electric.
 - b. Keep setting as low as possible.
 - c. A setting of 6-12 for servo or 40-50 for hydraulic or electric is an average place to start.
 - d. If LPM and required LPM are too slow matching up, bump up the SENS setting. Keep in mind that this will never be instantaneous, the display has a small delay.
 - e. CAUTION – Excessive play in the bell cranks, rod ends and spray valve must be kept to a minimum for Auto Cal II to perform at its peak.
 - f. Suggested Sens – Servo 8, Hydraulic or Electric 50.
5. HPM – Hectares per minute being covered at the current ground speed and selected swath width. Optional – Servo position or liters per hectare, most units are shipped using this optional information.
 6. SWATH – Swath width selected in meters.
 7. G/S – Current ground speed in miles per hour.

Operating Auto Cal II

1. Turn power on.
2. Select “oper” for operation mode.
3. Now the operator can select swath, width, sensitivity, or liters per hectare. (These selections can be made anytime the system is receiving a GPS signal.)
4. As the switches are operated, you can read your desired value on the remote display.
5. The selectable values, LPH, sensitivity, swath and calibration codes are stored in memory. The values will remain set even when Auto Cal II is shut down and powered up again. New values are stored as the operator changes them.
6. When warning light illuminates, the display will either read “GPS Signal Lost”, “GPS Bad 2”, or “Increase or Decrease Flow”. When it displays “GPS Signal Lost” the unit is not receiving ground speed and stops working. GPS Bad 2 indicates signal being received but not correct. When the display reads “Increase Flow or Decrease Flow” this means the flow rate through the booms cannot be controlled with the Auto Cal due to adjustment problems. To correct this problem, you should either adjust your fan, handle, or booms to adjust you boom pressure. For some applications, the handle will probably need to be closed to fix the “Decrease Flow Warning”.
7. When using a servo bypass regulating system, servo position is displayed above HPM and should be used for help adjusting flow. 1450 is valve ½ open. ***The fan should be adjusted for a no wind*** condition for the reading to be close to the 1450 number. This will help the Auto Cal II to be on target entering the field.
8. When turning on, the display will not advance to the spray screen if it is not receiving a GPS signal. A switch can be selected and held before turning unit on and that switch will be active. If a switch is not selected before turning unit on without a GPS, it cannot be selected without first turning unit off.
9. When the first two switches are up (on and open) the third switch can be used to increase or decrease the servo position or voltages to the electric motor or the hydraulic controller. This switch is used for presetting the dry gate opening to the desired position.
10. The Auto Cal unit can be operated in the Cal mode without GPS to see liters per minute that is being pumped while spraying.

Calibration

Height 4.13 cm – Width 9.37 cm – Depth 14.6 cm – Weight .4536 kg

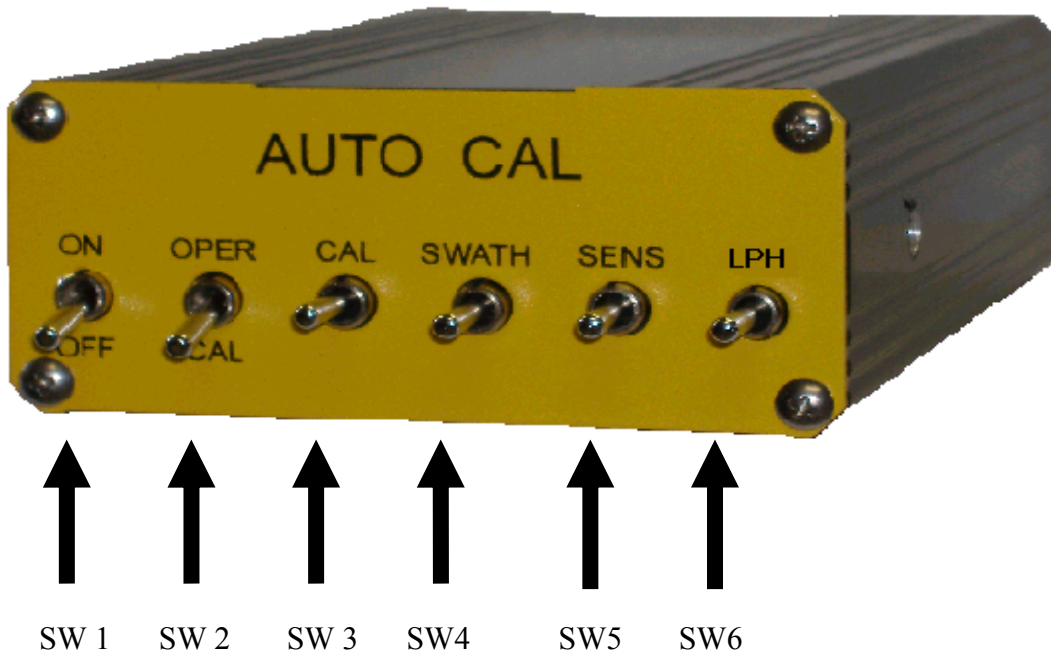

1. Select Cal on switch 2.
2. Switch 3 will increase or decrease cal code.
3. Notice the display format changes.
4. If you have SPD displayed in the cal mode, switch 6 will set the speed. The speed is used as a minimum speed and can be used for a minimum flow out of booms.
5. While pumping a known rate, liters per minute, through the flow transducer, simply adjust cal code until the proper liters per minute appears in the display.
6. If you already have a crop hawk installed, simply adjust the cal code until liters per minute matches LPM on your crop hawk.
7. If you are sure of the area that you are spraying and you are not coming out on target, a small correction to the cal code will fix the error.
8. Increasing the cal code will increase the amount of chemical being sprayed on the ground. If you put a 10 hectares load in and run out at 9 hectares, you are applying 10% too much. You would need to decrease your CAL code by 10%. This would put you very close. After this 1st adjustment, one or two numbers changed at a time should be done until the load fits the hectares.

Installation

1. Locate desired position in cockpit for computer. Preferred location is under instrument panel. **DO NOT** mount on *side* where water can drip or where the pilot might step on switches.
2. Install the display in full view of pilot. The display gives warnings, and if something is wrong, the pilot should not have to look down to read the display.
3. Install flow transducer adapter at a location that will allow interconnection with the flow transducer. NOTE: For crop hawk, the connectors are identical to crop hawk flow transducer and is simply a plug and play. The Auto Cal, Crop Hawk, or Micron Air will operate independently of each other with the one flow transducer.
4. Install a 5-amp circuit breaker in panel and label it “Auto Cal” Ref. 43.13.
5. Connect power (RED) wire of system harness to 5-amp circuit breaker, only after other wiring is completed to prevent accidental damage
6. Connect ground (BLACK) wire of system harness to ground of aircraft at same location that the GPS is grounded to.
7. All wiring, connection and routing to be I/A/W 43.13.
8. For wiring diagrams and overall view of systems, see applicable pages.
9. The average current on the Auto Cal II is less than 1 amp. The maximum current is limited to 5 amps by the circuit breaker.
10. The microswitch wire cannot share the same microswitch or relay contact that the GPS microswitch uses or **damage will occur**.
11. The control board has fuses on it for protection. Do **not** try to wire the system with power on or **damage will occur**.
12. The 1/3 boom, 1/2 boom, and high low flow wires do not have to be used unless needed. Open switch contacts are full boom and high flow. Wires must have separate switch contacts. No external power to contacts.

For any questions regarding installation, parts or operation, please call, fax, email or write the factory at 233 Safety Road – Houma, LA 70363 – (Tel) 985-868-1477 (Fax) 985-879-1617 – (email) autocalflow@aol.com

Block Diagram

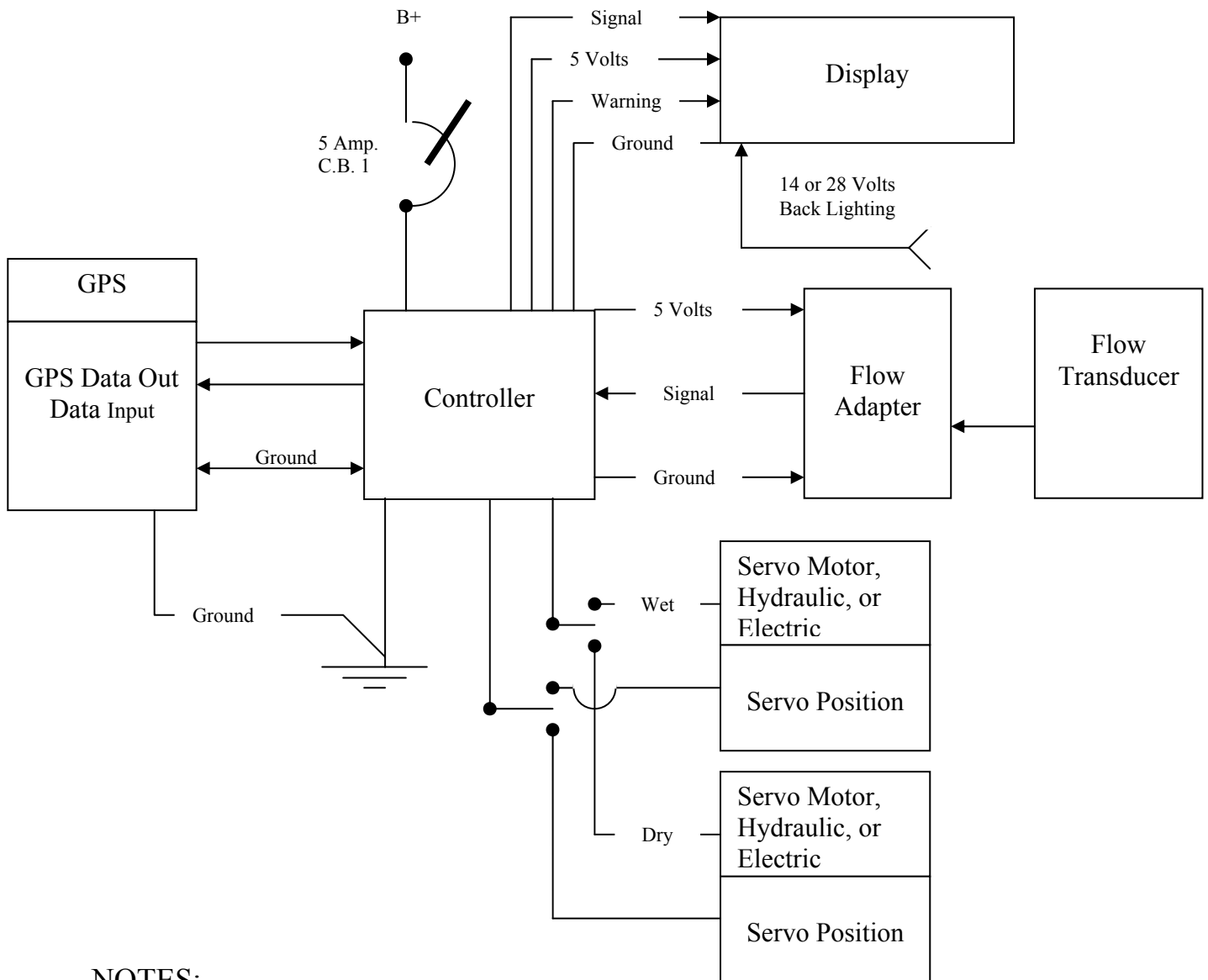

NOTES:

1. Units are made as 14 Volt or 28 Volt only.
2. A WET only or DRY only will not have a wet/dry switch.
3. The Flow Adapter is for wet and it will vary depending upon type of Flow Transducer used.
4. A Trimble, AgNav, Satlock, or Garmin GPS interface is not interchangeable.
5. The Wet Servo and Dry Servo will both run on either cable, but the servos have different gearing and length.

Installation of Flow Transducer Wiring (If aircraft has Flow Meter installed)

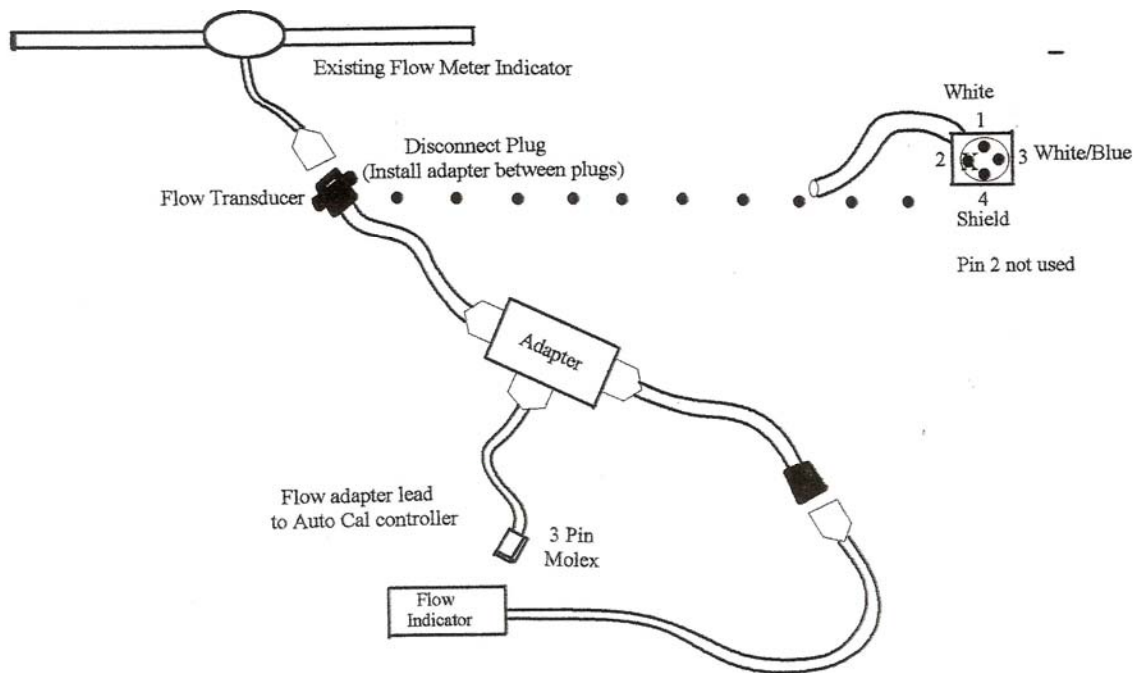

Installation of Flow Transducer (Typical on all models)

Install I/A/W aircraft manufacturer's installation procedure, typical instructions listed below:

1. Cut and remove a section of pipe between spray valve & spray boom.
2. Install flow transducer using hoses and clamps.
3. Route transducer wiring up to the flow adapter.

By Pass Regulating System

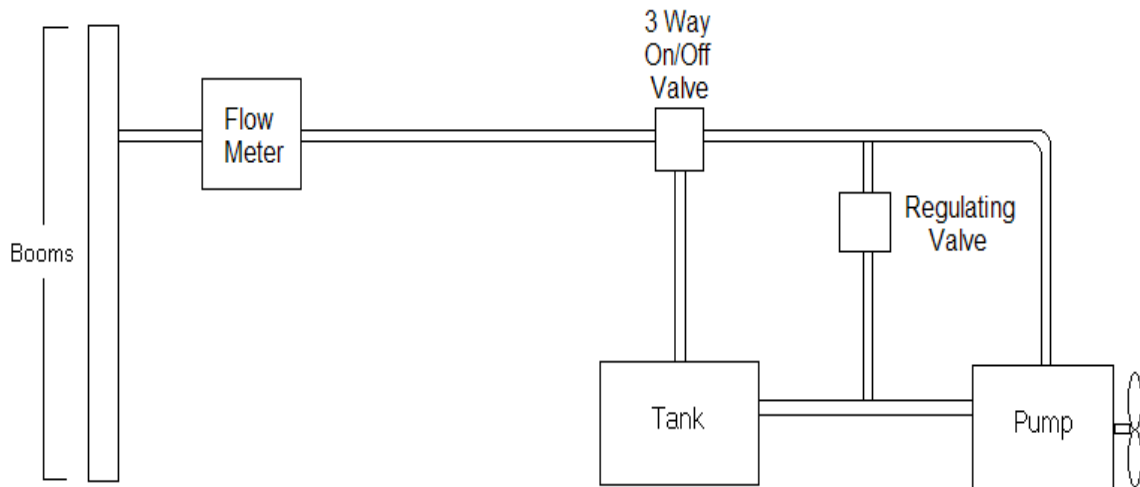

Auto Cal Bypass Valve Setup

This system re-circulates anything not needed by the boom, back through the pump.

The servo position is shown on the Auto Cal Display above HPM or APM.

If it is reading Below 350, the valve should be open.

If it is reading Above 2100, the valve should be closed.

If it is reading Between 1400 to 1500, the valve should be half opened.

This will be the place the valve goes while the aircraft is on the ground and receiving GPS signal.

The fan gets set to produce a position indication between 1400 to 1500 when spraying with no wind or with a crosswind. The pilot's spray handle should be all the way OPEN.

To run the servo, switch SW 1 to the "ON" position, switch SW 2 to the "OPER" position. When holding SW 3 (CAL Switch) in the up position, it will extend the servo. When holding SW 3 in the down position it will retract the servo. You will hear the servo when doing this. It is very important that the servo position goes to the extended and retracted positions and stops clicking while you are holding the switch. If clicking is still heard, a cable adjustment will be necessary.

GPS INSTALLATION

Note: This page does not apply when using existing spray GPS system to operate the Auto Cal II system.

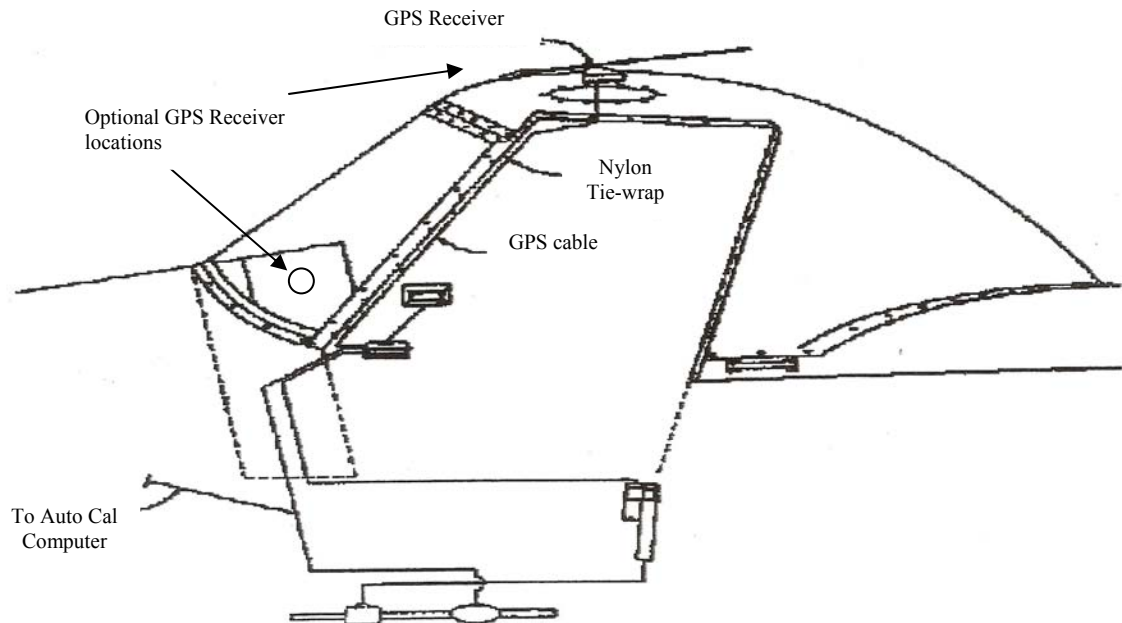

1. Using bracket supplied, locate and drill holes in to of fuselage.
2. Drill 1/4" holes for GPS cable.
3. Apply sealer under bracket before tightening screws.
4. Apply sealer around cable after pulling through 1/4" hole.

Note: GPS MOLEX PLUG INSTALLATION – The GPS is shipped without the plug installed to allow cable to fit through the 1/4" hole in the aircraft. The Molex plug is temporarily tied to the cable. Remove the Molex plug, pull cable through hole drilled in aircraft, install pins per interconnect drawing.

Interconnect Block Diagram

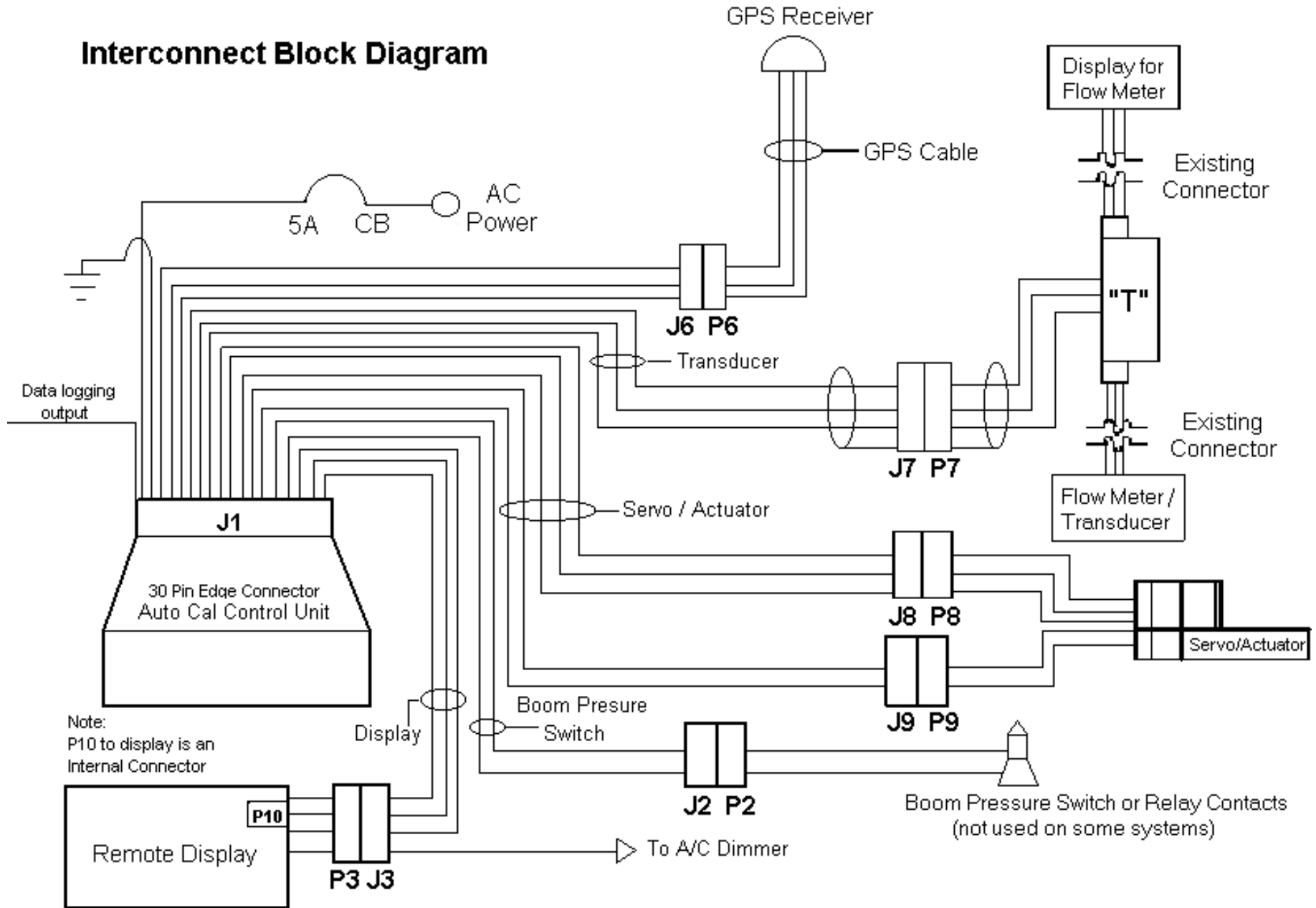

Interconnect

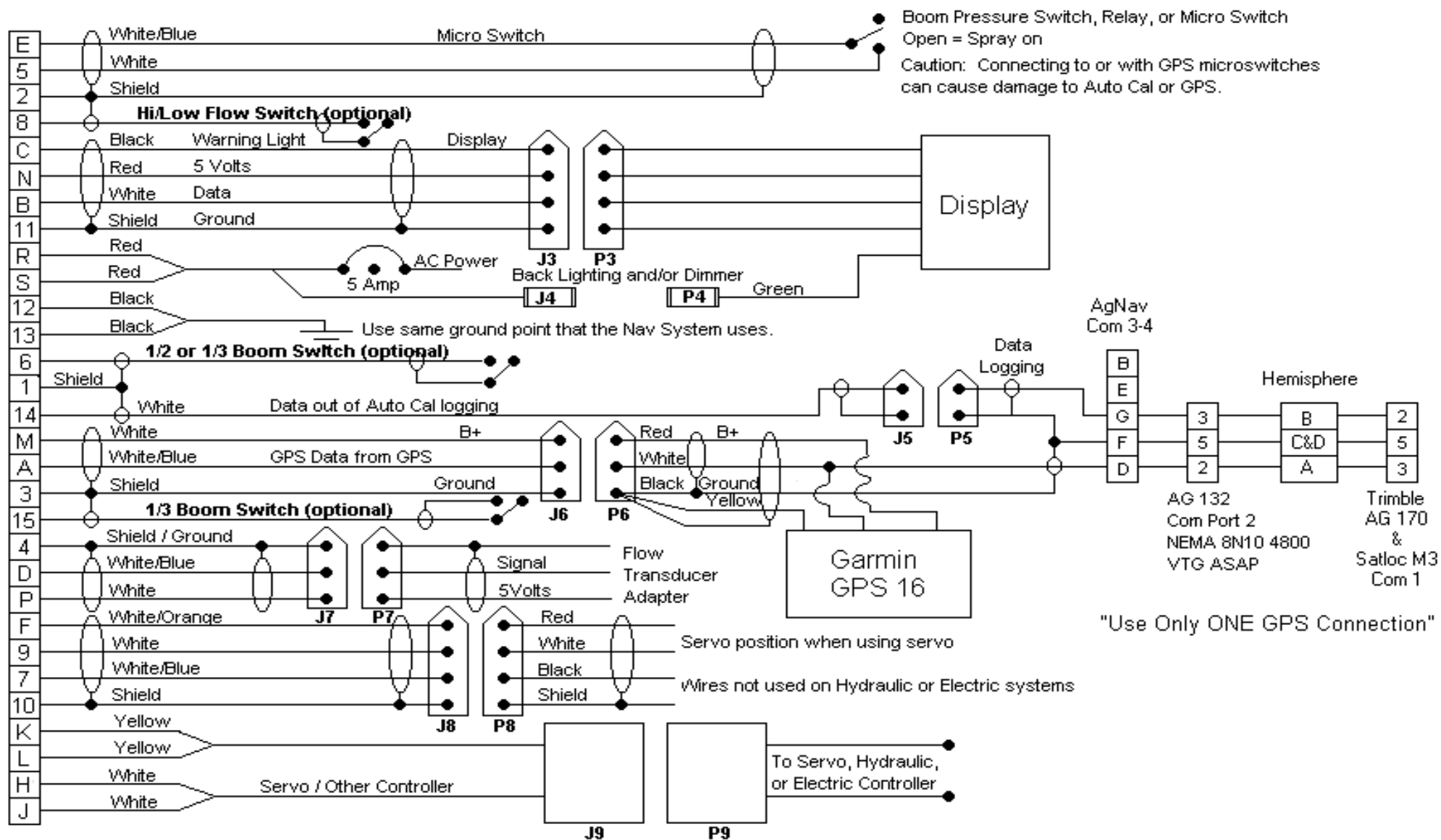

(SEE OTHER PAGES FOR MORE DETAILS)

Ag Air Hydraulic Interconnect

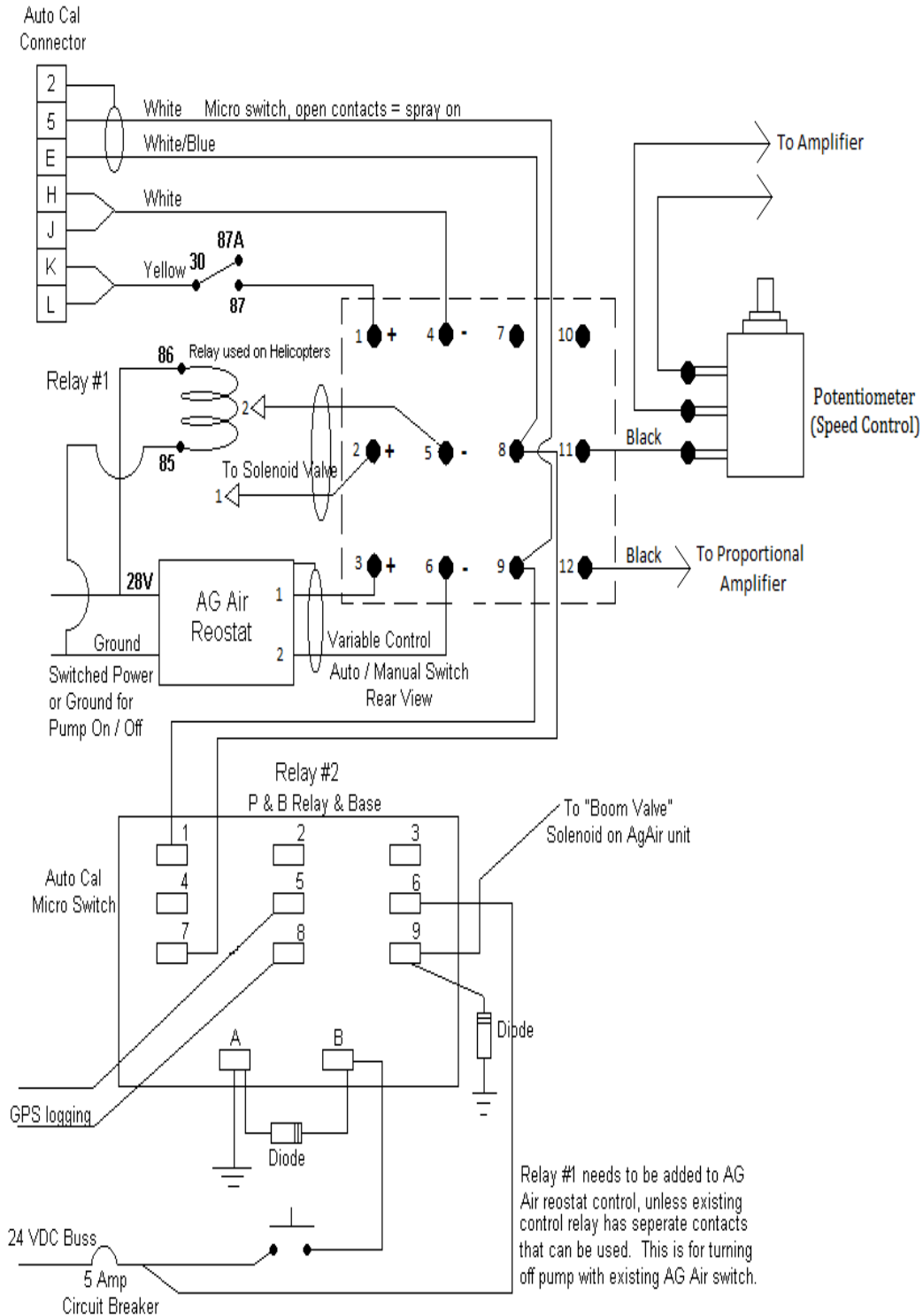

AUTO / MANUAL BOOMS CONTROL

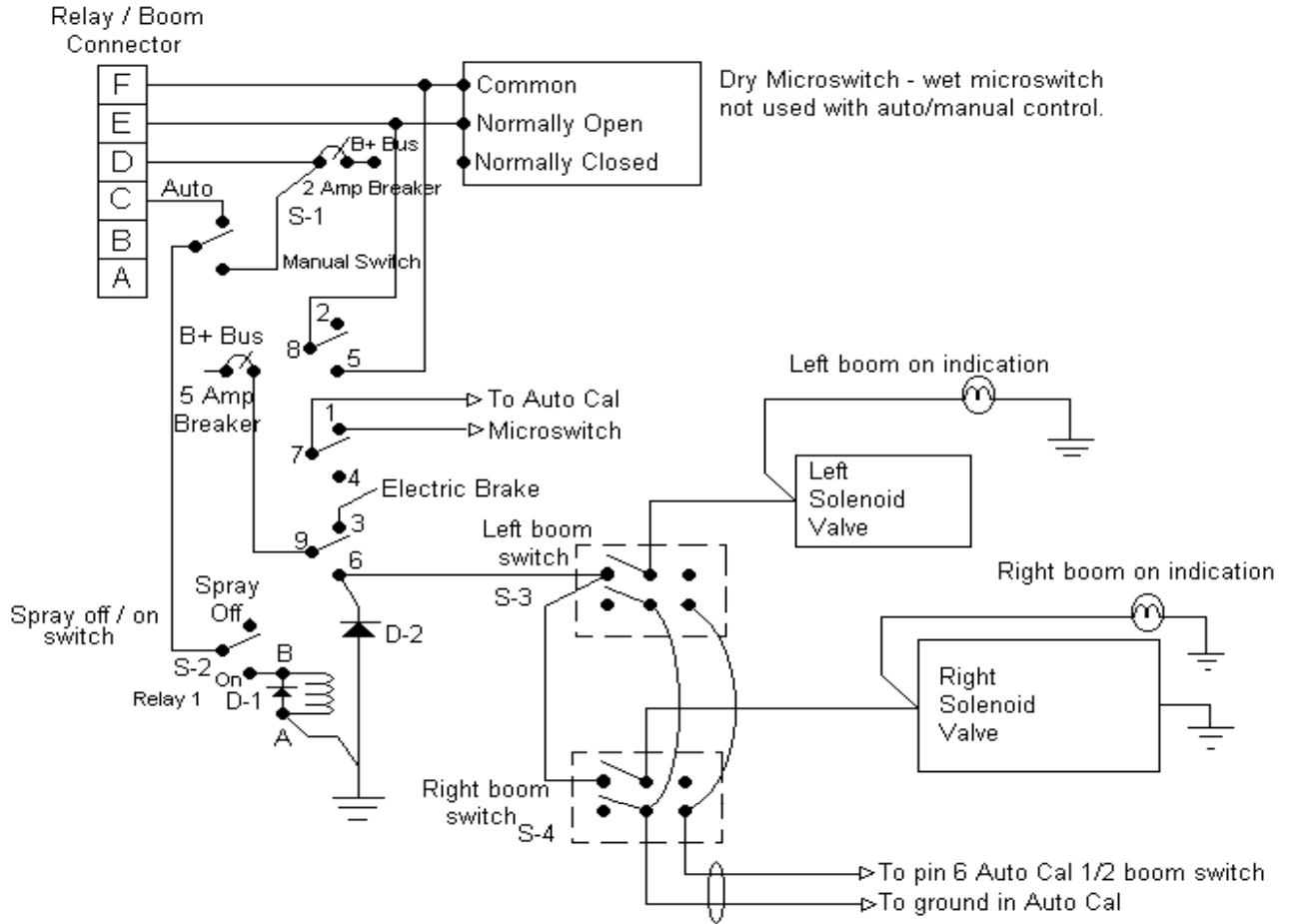

Helicopter version with 1/3 boom, S-3 & S-4 not jumpered.
Individual 1/3 & 1/2 boom to S-3 & S-4.

Spray On / Off switch should be located by throttle or spray on/off handle, this switch allows pilot to turn off at any time and if in the manual position on S-1 to turn on and off spray at the pilot's discretion.

4	Solenoid valves can be Air, Electric, or Hydraulic
3	S-3, S-4, GC 35-141 or equivalent
2	D-1, D-2, 1N4004 or equivalent
1	Relay 1 KUMP-14D18-24, Socket 27E121

Wet \ Dry Combo Servo Switching / 4 Pole Switch Rear View

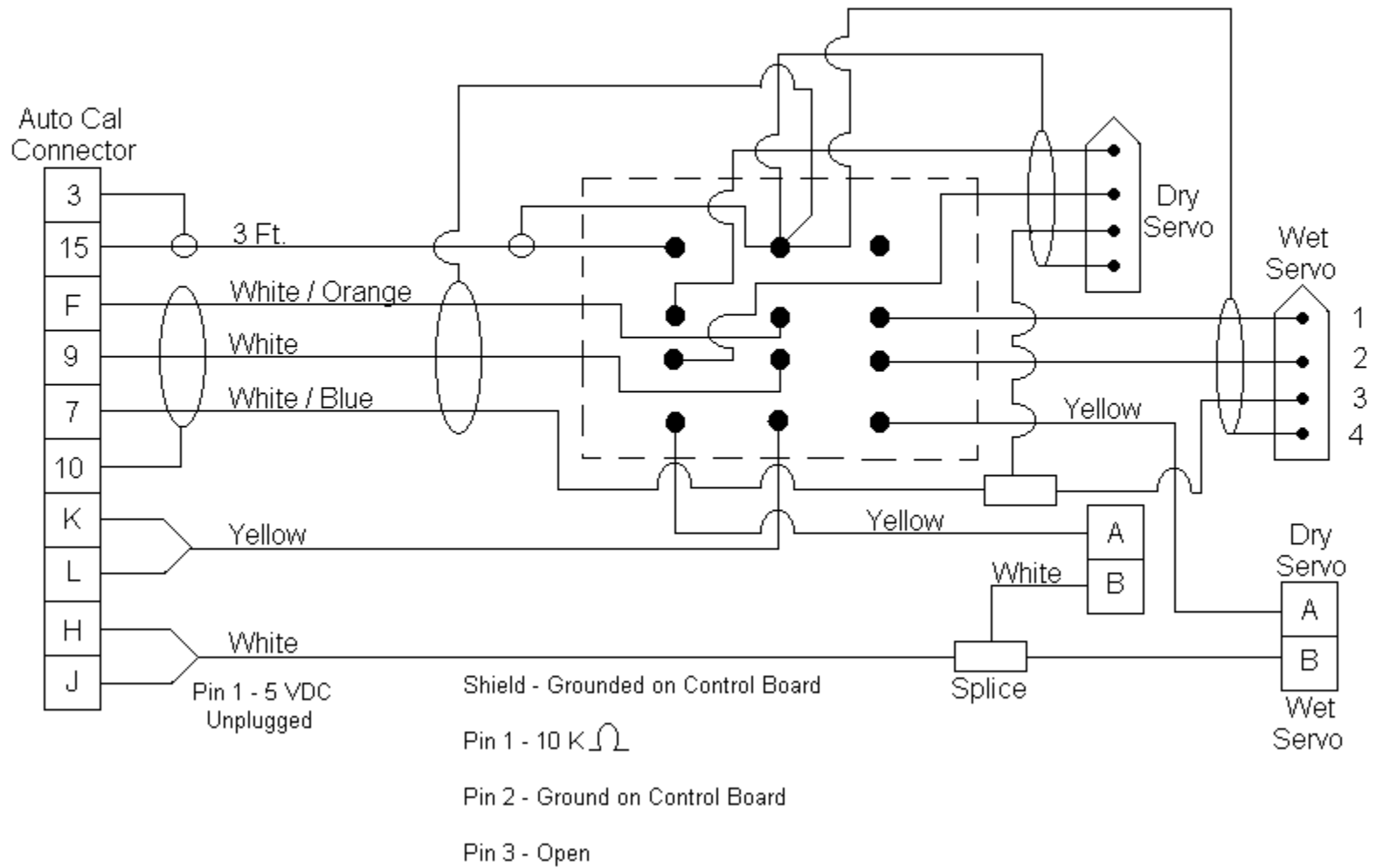

Data Logger

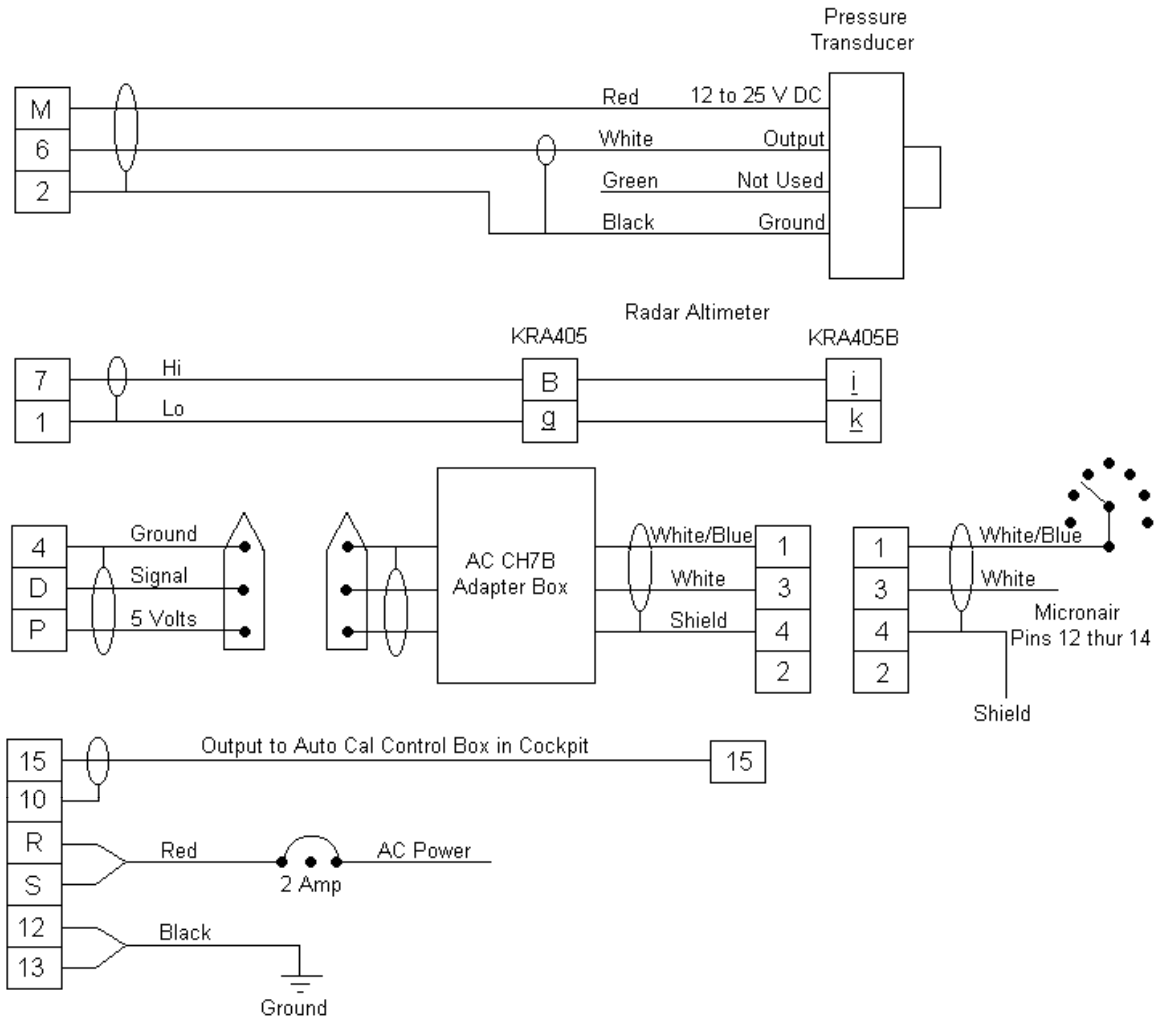

AUTO CAL - ACTUATOR FOR DRY

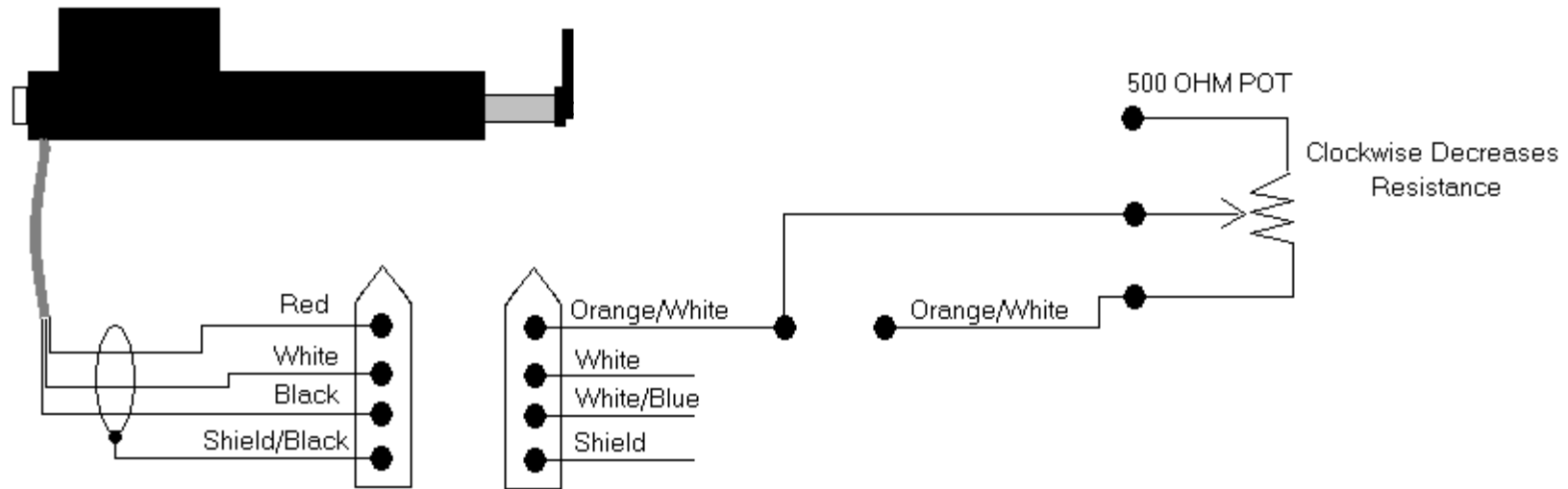

Cut Orange/White wire. Add potentiometer as shown in the diagram above. Mount the potentiometer where pilot can adjust it during flight.

To Operate:

Before starting: Set pot at 1/2 position (centered). Set actuator stop for 100 lbs or 100 kilos

In flight: The pot can be used to increase or decrease the output without using the switches. The switches can only be used on the ground.

On the ground: Look at the handle stop on the actuator. Set the pot back to the center, using the switches to reset the actuator to where it was before centering the potentiometer. The system always uses 100 Kilos or 100 lbs as the default rate. If the Cal Code is correct, and you go 75 on the rate, the handle will pull back to the 75 lb or 75 kilo position. When you go back to 100, the stop will go to the 100 position. To set the cal code, you must be using the same swath for both rates. On later systems, if a 1/2 Boom Switch is installed, it can be used to go from 100 to 50 on the rate, for help in setting Gate Cal Code.

Note: When you change swath width, the 100 position will be different. Look at the records for your airplane, for the new 100 position for the new swath width. When the unit boots up, the speed shown is the average spray speed. This can be set in the cal mode using the GPA or LPM switch. Most speeds are set in MPH. The Auto Cal Simulator only outputs knots or kilos.

AUTO CAL CALIBRATION METRIC

<u>CAL CODES</u>	<u>FLOW RATES</u>	<u>JUMPER POSITION</u>
TM0100 – Low Flow Position About – 155	Minimum – 15 LPM Maximum – 190 LPM	Left Side
TM0150 – High Flow Position About – 270	Minimum – 50 LPM Maximum – 680 LPM	Left Side
AC0200 – High Flow Position About – 137	Minimum – 150 LPM Maximum – 1500 LPM	Right Side
AC0300 – High Flow Position About – 150	Minimum – 227 LPM Maximum – 2270 LPM	Right Side

Crophawk 2” Flow meter jumper on the right side
Basket #1 High Rate Flow / Cal Code = 260
Basket #2 Low Rate Flow / Cal Code = 210

Micronair Flow Meters that are the same size as the Turbine Flow Meters would be the same Cal Codes as the Turbines

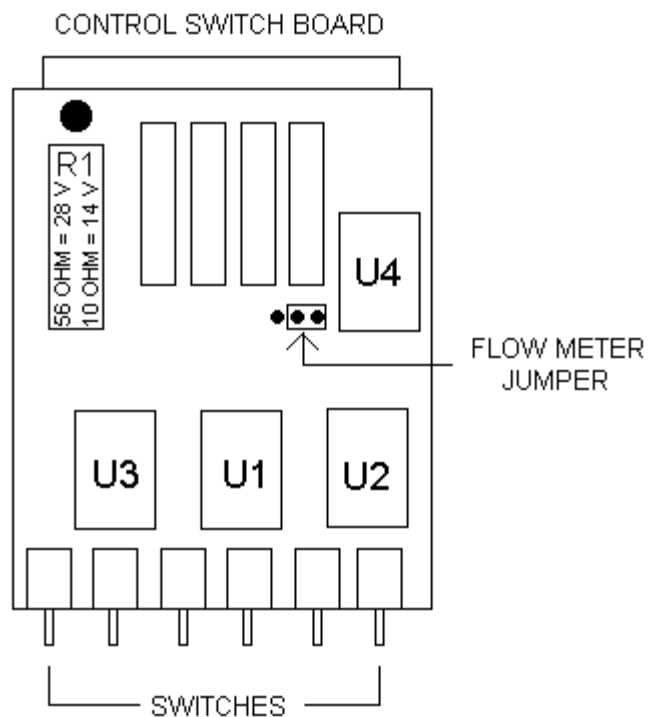

Diagram represents Crophawk 2” – showing jumper in right position (Spare pin on left side)

Move jumper to the left side (spare pin on right side) for TM0150 and smaller Flow Meters

If your display has FM on the screen when in CAL MODE, please see next page.

FOR USE IF AUTO CAL DISPLAYS FM
 FM IS FOR FLOW METER SELECTION - TO CHANGE THE FM, WHILE IN CAL, USE THE SWATH
 SWITCH - THERE IS A DELAY

METRIC CAL	HI/LOW FLOW SWITCH	CAL CODE	LPM
FM 1 TM0038	LO	420	1.14 TO 11.36
FM 2 TM0050	LO	463	2.48 TO 28.39
FM 3 TM0075	LO	411	7.50 TO 56.8
FM 4 TM0078	LO	491	11.0 TO 113
FM 5 TM0100	HI	360	19.0 TO 190
FM 6 TM0150	HI	343	57.0 TO 680
FM 7 TM0200	HI	188	151 TO 1500
FM 8 TM0300	HI	119	227 TO 2270
FM 9 CROPHAWK	HI	138 (MOVE JUMPER ON CONTROL BOARD TO RIGHT SIDE)	
FM 9 TM0100	LO	155 (MOVE JUMPER ON CONTROL BOARD TO LEFT SIDE)	
FM 9 TM0100	HI	500 (MOVE JUMPER ON CONTROL BOARD TO LEFT SIDE)	
FM 9 TM0150	HI	260 (MOVE JUMPER ON CONTROL BOARD TO LEFT SIDE)	

WHEN USING FM 9 SETTING, THE CALIBRATION SETTINGS WOULD BE THE SAME AS FIRST PAGE AND YOUR CAL CODES WOULD BE THE SAME AS THEY WERE BEFORE THE CHANGE.

FLOW METER SPECIFICATIONS

PART #	FLOW AREA	CONNECTION TYPE	MIN / MAX LPM	MIN / MAX GPM
TM0038	.38 INCH	0.5" MALE NPT 1.0" MALE NPT	1.14 / 11.36	.30 / 3.0
TM0075	.75 INCH	0.5" MALE NPT 1.0" MALE NPT	7.57 / 56.78	2.0 / 15
TM0100	1.0 INCH	1.0" MALE NPT	19 / 190	5.0 / 50
TM0150	1.5 INCH	1.5" MALE NPT	57 / 680	15 / 180
TM0200 (TRUCK / TANK ONLY)	2.0 INCH	2.0" FEMALE NPT	151 / 1500	40 / 400
TM0300 (TRUCK / TANK ONLY)	3.0 INCH	3.0" VICTAULIC CONNECTOR	227 / 2270	60 / 600
AC0200	2.0 INCH	2.0" W/CLAMPS, GASKETS, AND FERRULES TO BE WELDED TO PIPE	151 / 1500	40 / 400
AC0300	3.0 INCH	3.0" W/CLAMPS, GASKETS, AND FERRULES TO BE WELDED TO PIPE	227 / 2270	60 / 600

ADDITIONAL CABLE REQUIRED FOR FLOW METERS:

PT# AC10354-01