

Project: \_\_\_\_\_

Type: \_\_\_\_\_ Quantity: \_\_\_\_\_

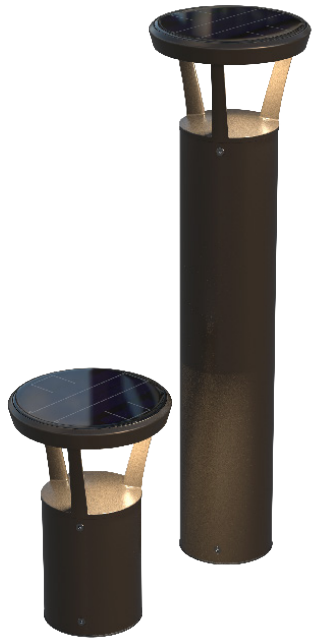

The PLB series solar powered LED bollard is ideal for architectural and commercial pathway applications. The stylish, contemporary design combined with high quality construction and unequalled solar powered performance make the PLB series an excellent fit where quality lighting is required.

PLB solar powered bollards are fully self-contained and offer significant advantages over typical wired bollards:

- Low installation, remediation and electrical design costs
- No electricity bills and no scheduled maintenance
- Immune from power outages
- A sustainable choice without recurring carbon emissions

All of our solar powered lights are enabled by our innovative Solar Lighting Controller (SLC). The SLC in each light is “self-learning” and allows the lights to predictively adapt to their surroundings, providing a level of lighting performance and reliability unavailable in other solar lighting products.

## TECHNICAL SPECIFICATIONS

- Solar Module:**
- High impact, UV resistant encapsulation
  - High-efficiency mono-crystalline cells
  - Integrated into bollard housing
  - Used for day/night detection (no photocell required)

- Solar Lighting Controller (SLC):**
- High efficiency Maximum Power Point Tracking (MPPT) charge controller
  - Micro-controller based technology
  - High-efficiency LED driver
  - Integrated into bollard housing
  - Designed to automatically manage lighting performance based on environmental conditions and lighting requirements

- Battery:**
- High performance lithium (LiFePO<sub>4</sub>)
  - Exceptional 8 – 10 year life cycle
  - High temperature tolerance
  - Contained within bollard post
  - Easy battery changes when required
  - Plug-and-play, sealed connector

- LEDs and Optics:**
- High output Cree LEDs
  - Greater than 100,000 hour L70 lifetime LED
  - Warm (3000K) and neutral (4000K) white color temperatures available
  - Type 3 full cut-off and Type 5 cut-off high efficiency optics
  - IP67 protection
  - Typical lumen output of 239 - 370 lumens

- Mechanical Construction:**
- Cast, low copper aluminum housing
  - Extruded, low copper aluminum post
  - Stainless fasteners with security fastener option
  - High strength mounting base
  - Architectural grade, super durable, TGIC powder coat
  - Four standard colors with custom colors available

- Factory Set Lighting Profiles:**
- On at dusk, off at dawn
  - On at dusk, turn off after 6 hours
  - On at dusk, dim to 30% after 6 hours till dawn
  - On at dusk, off after 5 hours, on 1 hour before dawn
  - On at dusk, dim to 30% after 5 hours, on 1 hour before dawn

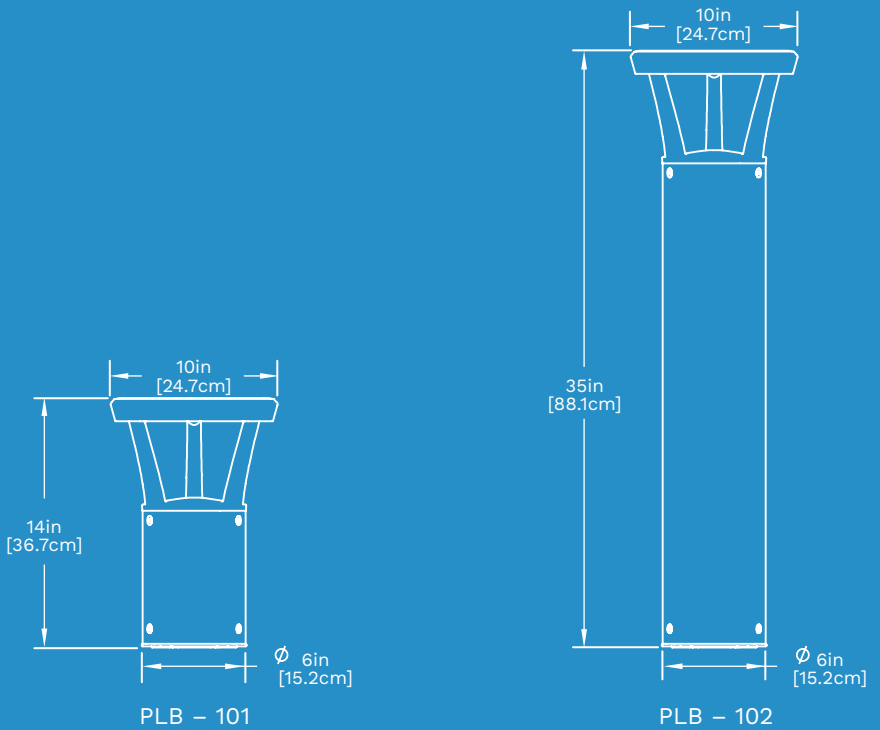
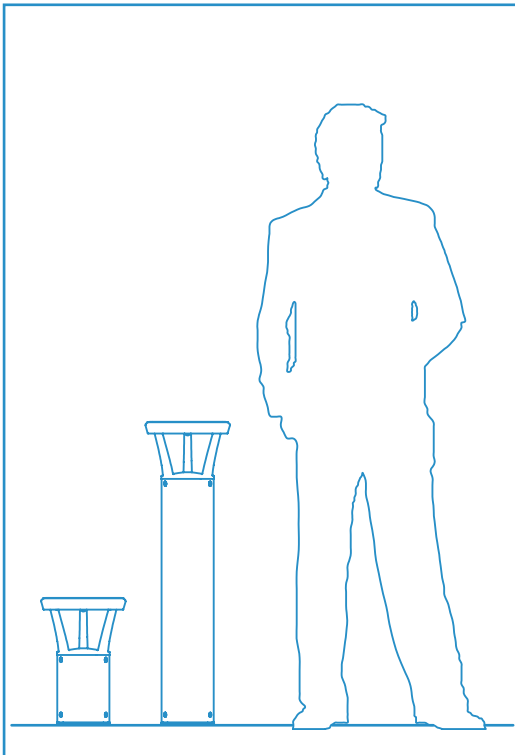

**PHOTOMETRICS** (IES files available on website)

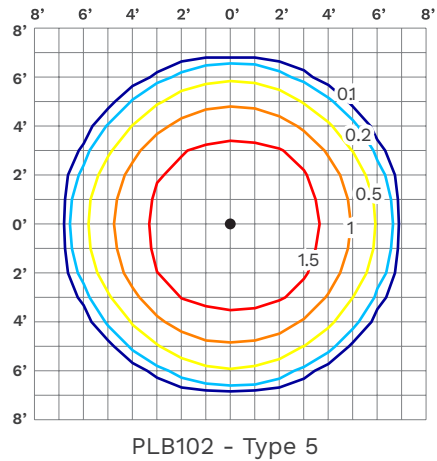
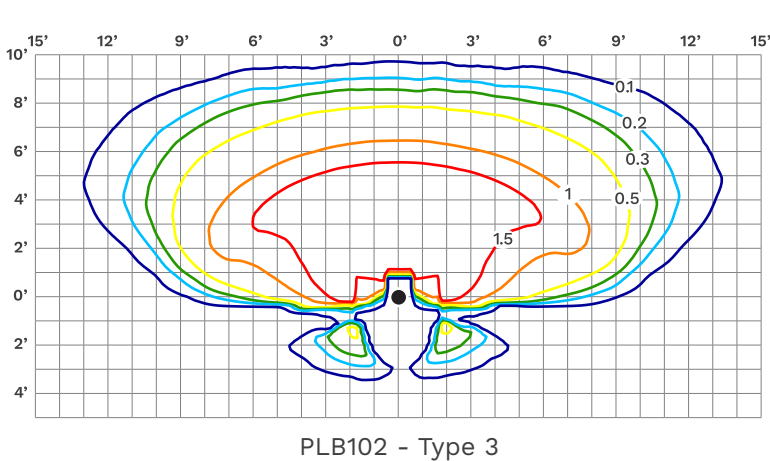

- Notes:**
- Specifications subject to change without notice
  - Photometrics based on PLB 102 mounting height
  - All light levels in foot candles (fc) with 4000K color temperature and 300 lumen output
  - To convert to lux multiply light level by 10.7

**ORDER MATRIX**



Series	Height	Finish	Distribution	LED Color	Lighting Profile	Options
<b>PLB</b>	<b>101</b> - 14"	<b>BK</b> - Black	<b>ASM</b> - Type 3	<b>WW</b> - 3000K	<b>00</b> - On at dusk, off at dawn	<b>SEC</b> - Security Fasteners
	<b>102</b> - 36"	<b>BZ</b> - Bronze	<b>SYM</b> - Type 5	<b>NW</b> - 4000K	<b>01</b> - On at dusk, off after 6 hours	<b>PA</b> - Pre-Ship Anchor Bolts
		<b>SV</b> - Silver			<b>02</b> - On at dusk, dim to 30% after 6 hours	
		<b>WH</b> - White			<b>03</b> - On at dusk, off after 5 hours, on 1 hour before dawn, off at dawn	
		<b>CC</b> - Custom			<b>04</b> - On at dusk, dim to 30% after 5 hours, on 1 hour before dawn, off at dawn (default)	