

**Master Cylinder Installation**  
**For Pilot side only and dual Brakes**  
**Brake line Installation**

**Required Items:** 2 pedal assemblies, 2 master cylinders (std) 4 if dual brakes, 7 90 degree line fittings (std) 4 extra for dual brakes, 1 T fitting, 4 AN3-7A, 4 AN3-12A, AN3 nyloc nuts, 3/16 washers, plastic brake line.

1. Locate the 2 pedal assemblies, part #ALR-0030, the assemblies are identical.
2. If your kit does not have the powder coated parts, you must first de-grease the metal and prime with a self etching primer then paint what color you like.
3. Drill out the holes in the mounting tabs for the MCs with a #10 drill bit.
4. Note that the brake pedal is tilted back some from the main tube. This keeps your feet off of the brakes unless needed.
5. Depending on the amount of tilt you want the MC can be adjusted for it, we suggest some tilt do not build them parallel. And in some cases the treaded end of the MC can be cut down some to allow the end to tread on further.

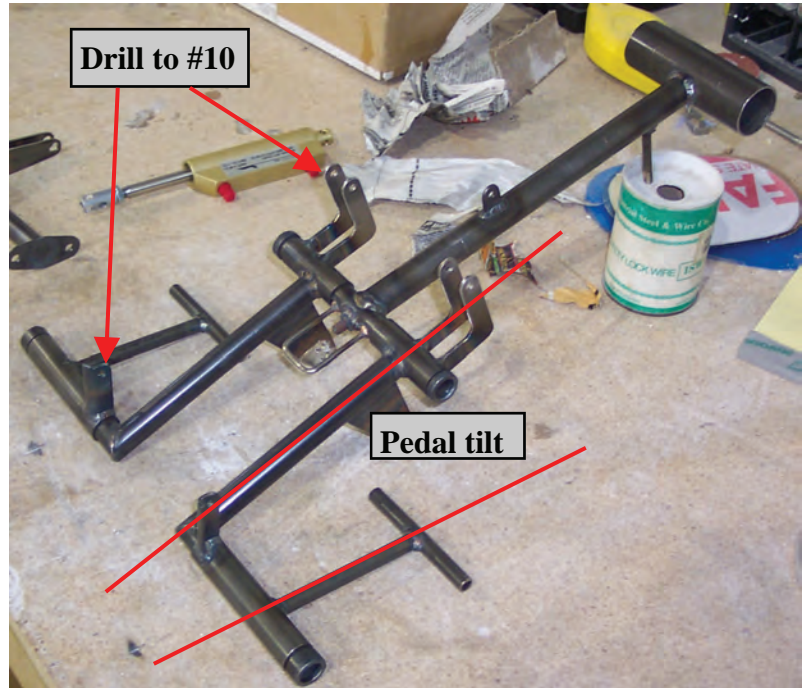

6. Install the 90 degree fittings on to the MCs, the top fitting can be faced vertically with the bottom fitting faced slightly towards the firewall so that the brake lines will not interfere with each other.
7. The MCs must be installed as shown with the fittings facing inward.
8. Slide the shown bolts in to the correct locations, The upper bolts will normally have 2 washers on the insides and the bottom bolts have the 1 on the side of the attach fork
9. Do not tighten them completely the bolt should be free and the pedal operate with out binding.

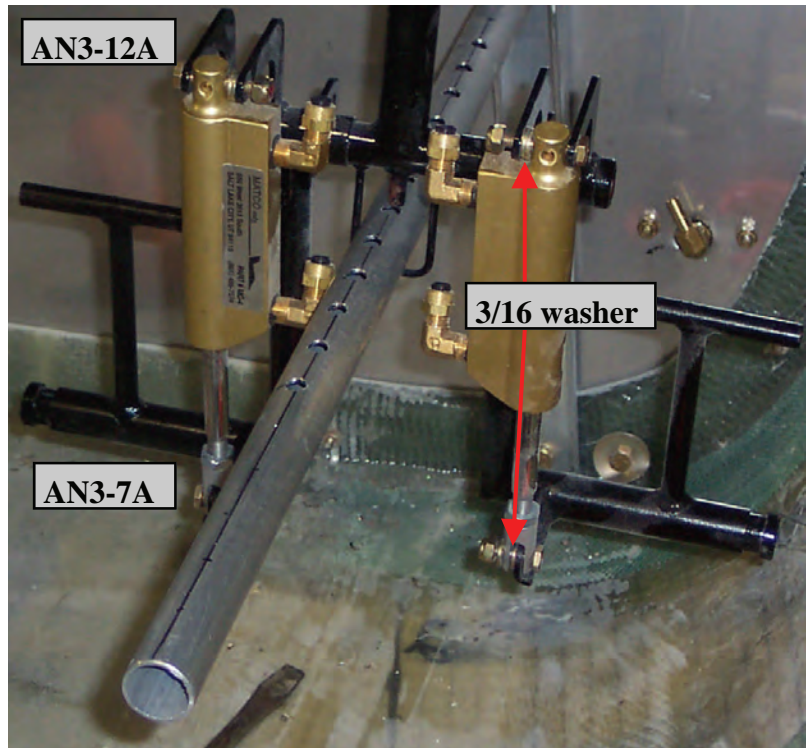

10. Repeat for the other set of pedals if installing dual brakes.
11. If not dual brakes, fabricate a part to fit between the 2 MC mounting tabs. Or the retaining rings at the ends of the brake pedal may be cut off and the pedal removed.
12. These can be a push rod assembly as shown or a 1/2" 4130 steel tube of proper length, this material is not supplied in the kit

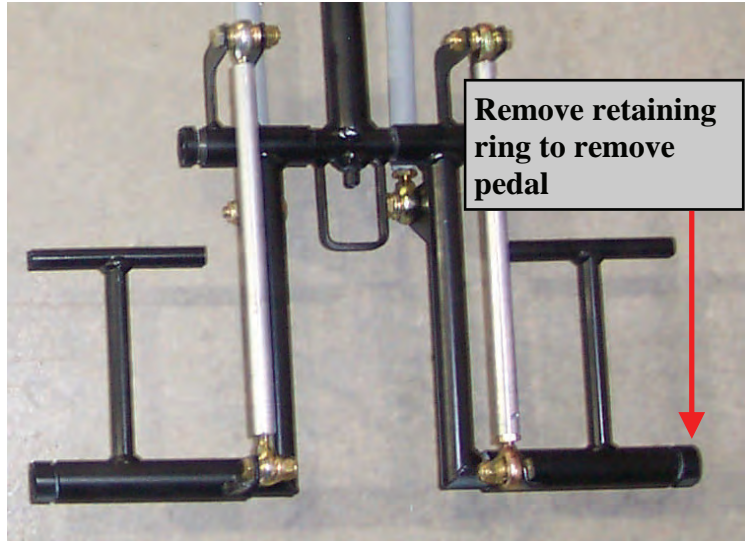

13. The picture to the right shows how the bottom lines must run on behind the top lines than up around the pedals to the T fitting.
14. When running the line remember that they must have enough slack for the pedal adjustment to operate properly, and that when running the line from the top fittings down the center console it is good to have a large loop at the top to allow them to move freely.
15. Use some 1/4" ID plastic tubing around the brake line in areas where it might rub on another part.
16. Use the diagram below for proper plumbing of a single or standard brake setup.

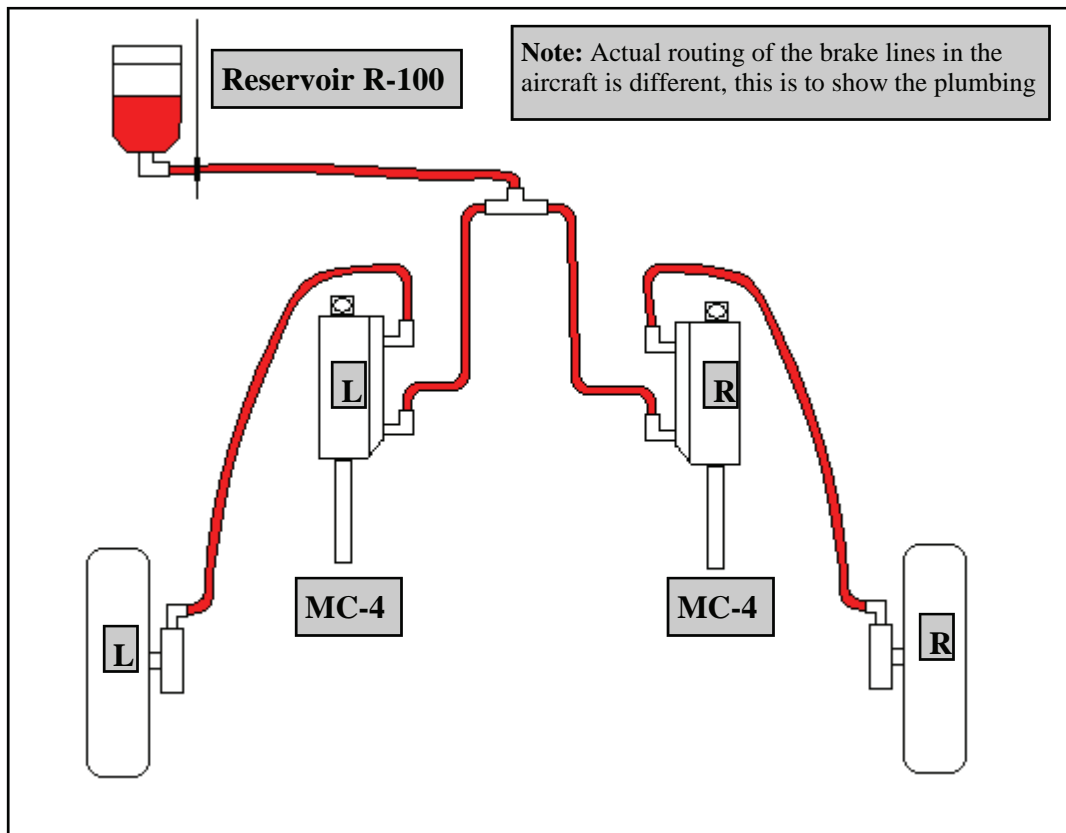
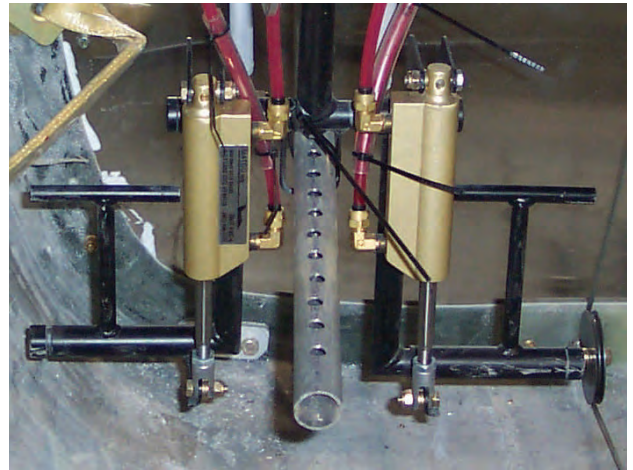

17. Use the diagram below for the proper plumbing of a dual brake system in the Lightning.

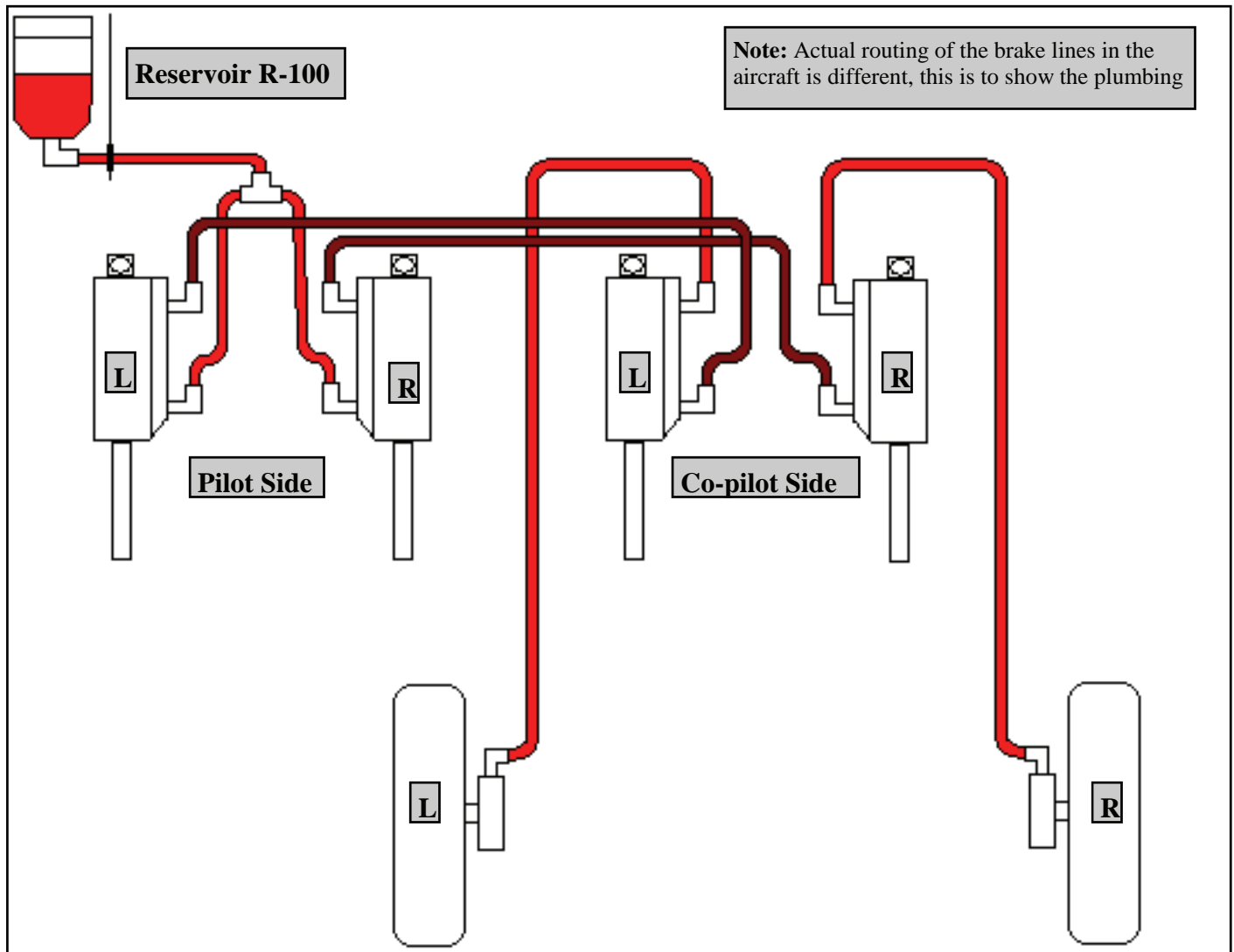

18. Use the picture as a reference, the brake lines are run up from the spar box with a large loop up to the sub bulk head. This keeps them from being pulled when the pedals are adjusted.
19. Installing an adle clamp at the top ( cushion clamp) keeps the brake lines from getting to out of hand, do not make the clamp tight on the line, it should be large enough so that all it does is keep them in the right place.

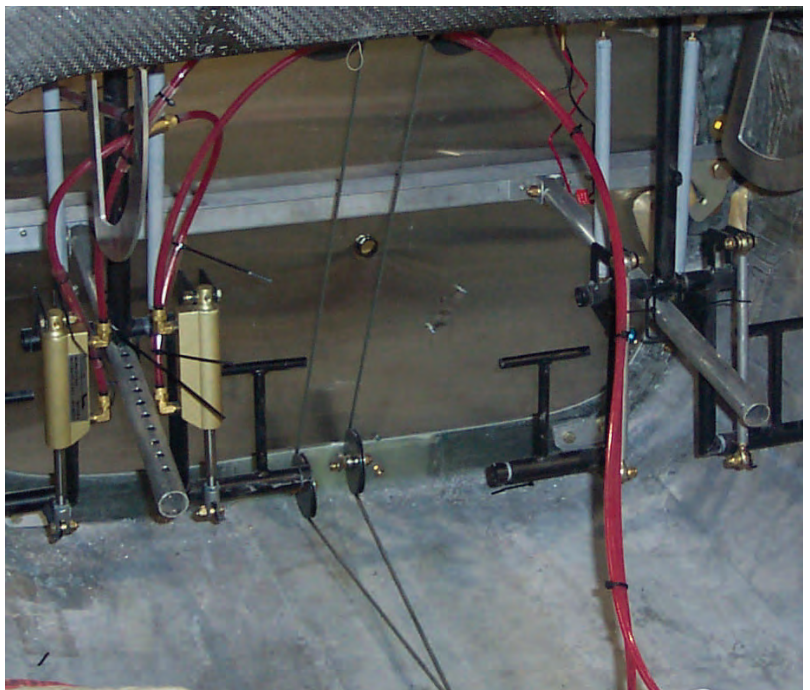

20. The photo shows the use of clear plastic line around the brake line in areas where the line may rub.
21. Note the T fitting and how it runs thru the push rods, in this aircraft this worked, however this may not be ideal for yours. The most important part is that the lines are not bound up in any way when the pedals are moved with rudder application and when the pedals are adjusted for pilot height.

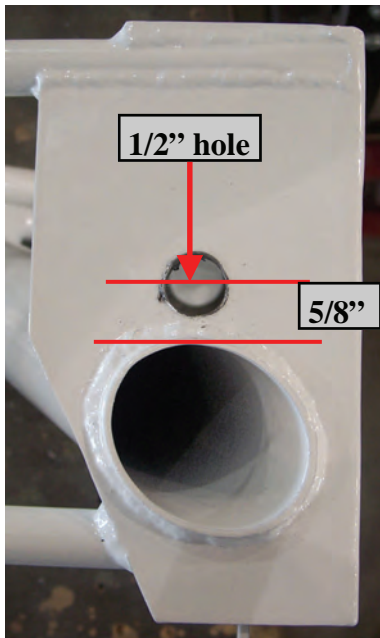
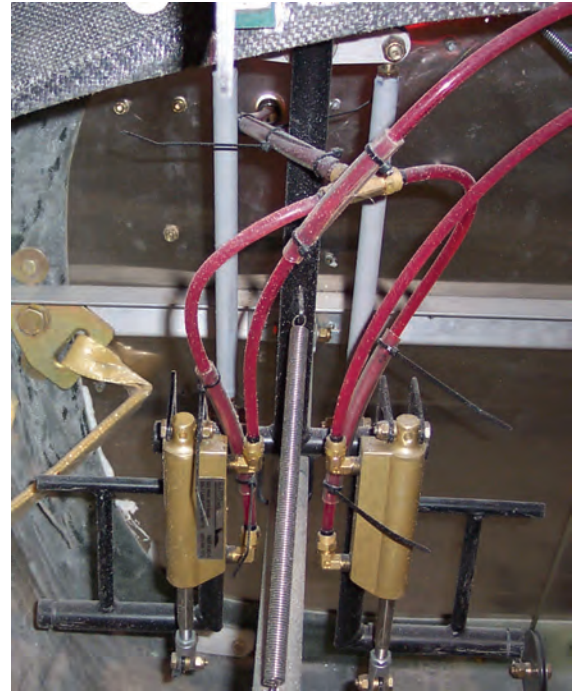

22. In the bottom of the rear spar box measure forward from the main gear leg socket 5/8", and in line with the socket. You should measure from the edge of the hole not the weld.
23. Drill a 1/2" hole here. Start with smaller bit and work your way up, this will be more accurate.
24. When running the brake line thru here a piece of 1/4" fuel line can be used as a grommet to prevent wear.

25. Matco Mfg does offer a parking brake valve.
26. This must be installed in the brake lines before they enter the master cylinders, and in the case of a dual brake system the first set of master cylinders that the brake lines enter.
27. This can be ordered as an option

