

Specifications				(The wire rope composition is a manufacturer recommendation.)
Load Rating Wire Rope Tension	1,100 lbs (=500 kgf)	Handle Force	Handle Length 9 27/32"	18.7lbs (=8.5kgf)
Wire Rope Diameter	φ 1/4" (6 × 36)		Wire Rope Tension 1,100lbs	
Gear Ratio	1/8.9	Standard Accesories		One Handle
Effective Handle Length	9 27/32" (Maximum)	Painting		Melamine Resin Coating At Two Layers Painting Color Drum : Black (Munsell N1 Semi Gloss) Others : Munsell 7.5YR6/11
Weight	39.2 lbs (Winch + Handle)			

※Model MC winch is designed only for horizontal pulling.  
Never use this winch for vertical lifting.  
It may result in serious accident and breakage of the winch.

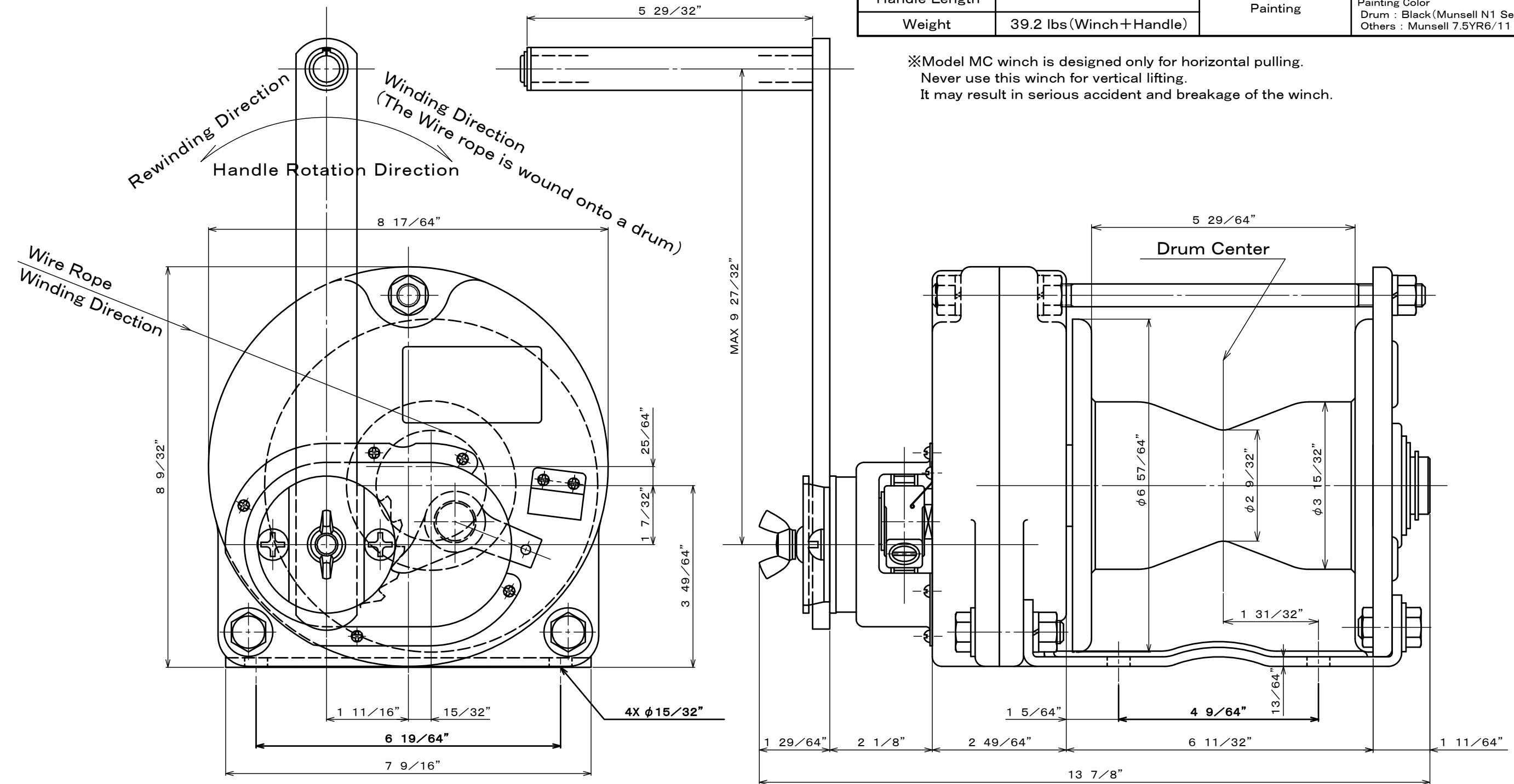

4 × 3 × 2 × 1 × 改訂 / REVISION	図面番号 / DRAWING No. <b>MC5-180402-01U</b>	改訂番号 / REVISION No. <b>00</b>	お客様 / CUSTOMER	符号 / MARK	項目 / PARTICULARS	材料 / MATERIAL	数量 / QTY	単体重量 (kg) / TOTAL WEIGHT	備考 / REMARKS	
	承認 / APPROVED 	検図 / CHECKED 	作成 / DRAWN 	図面名 / TITLE <b>MAXPULL WINCH CAPSTAN TYPE MODEL MC-5</b>	投影法 / PROJECTION METHOD 第三角法 / THIRD ANGLE PROJECTION 尺度 / SCALE : 台数 / QTY	<b>MAXPULL MACHINERY &amp; ENGINEERING CO., LTD.</b> <b>マックスプル工業株式会社</b>				