

FIREDRAGON Field Notes © #200 Test Set

GA1 – Test Adapter for Honeywell SmartValves™

The GA1, **Figure 1**, allows for electrical troubleshooting of the Honeywell Gas SmartValve™ Series and upgrades and replaces Honeywell's 396085 GA1 Testing Harness. These instructions will reference the 81B Victor multimeter, **Figure 2**.



Figure 1

The GA2 Test Adapter helps a qualified technician to confirm proper appliance control operation in the field. When installed between the appliance wiring and the gas valve, the GA2 Adapter can easily introduce a multi-meter or voltmeter to the circuit. This will allow you to observe the input voltages from the system controls to the gas valve. The following are the mandatory steps for connecting the GA2 Adapter to Honeywell SmartValve™ models SV9X00, SV9X01, SV9X02, and SV9X03.

NOTE: Do not use the GA2 with SV9X10, SV9X20, and SV9X40 SmartValve™ Systems that control combustion air blowers and monitor airflow proving switches

WARNING: Prior to using the GA1 Test Adapter read these instructions carefully.

1. Failure to follow the instructions can damage the appliance control set, the gas valve and the meter. In addition, inaccurate readings will be obtained making the test procedure useless.
2. Serviceman/installer must be a trained, experienced (licensed) service technician, familiar with the sequence of operation of gas appliances.

REQUIRED ITEMS:

Use the following items to attach and test SmartValve™ Systems with the GA1 Adapter:

1. The GA1 Adapter, Figure 1.
2. Multi-meter or voltmeter with an AC voltage scale (Vac), Figure 2.



Figure 2

TEST PROCEDURE

NOTE: Leave the SmartValve™ switch in the ON position, **Figure 3**. Turn off gas supply at the appliance shut-off valve.

1. Make sure the appliance is powered.
2. Lower the temperature controller setting to make sure there is **no call for heat**.
3. Disconnect the appliance wiring (Figure 3, CONTROLS CONNECTOR) from the SmartValve™.
4. Connect the GA1 Adapter between the appliance wiring and the SmartValve™ in place of the connector removed in Step 4, **Figure 4**. Make sure the keyed connectors lock into place. Make sure your meter is connected properly.

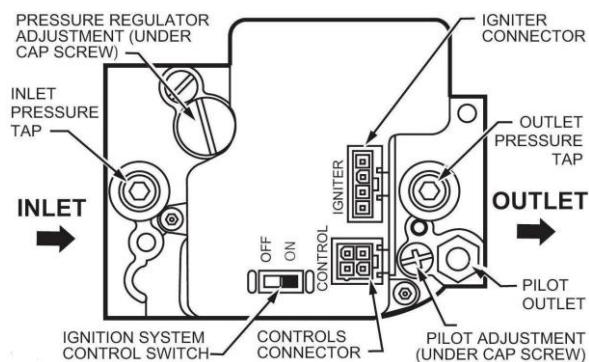

Figure 3

- a. Insert the **BLACK** test lead into the **COM terminal** and the **RED** one into the **V/Ω/Hz terminal** of the meter.
- b. Insert the **BLACK** test lead into the GREEN (COMMON) wire.
- c. Insert the **RED** test lead into the YELLOW (HOT) wire test points of the GA1.

5. Turn the selector knob to $V \sim$ range.
6. Auto range is the original mode, it will display AUTO symbol.
Press the RANGE key to change to the manual range mode, 400mV, 4V, 40V, 400V, 750V range is selective.

NOTE: When measuring Vac under auto range mode, pressing the **RANGE** key will display AC mV range.

7. Measure the voltage between the 24 Vac HOT (YELLOW wire) lead and the 24 Vac COMMON (GREEN wire) lead on the GA2 Adapter. If the voltage is less than 20 volts or more than 28 volts, check the appliance power supply and the system transformer for proper operation.

NOTE: If an appliance is wired so the 24 Vac HOT lead is controlled with the 24 Vac TSTAT/PSWITCH (RED wire) lead, there is no voltage between the 24 Vac HOT lead and the 24 Vac COMMON (GREEN) lead in Step 6.

8. Disconnect the meter test leads from the 24Vac HOT (YELLOW wire) lead test point of the GA1.
9. Connect the meter test leads to the 24 Vac TSTAT/PSWITCH (RED wire) test point of the GA2.
10. Set the temperature controller so it calls for heat.
11. Make sure the meter displays nominal 24 Vac while the light-off sequence progresses, and the reading is steady with the element glowing.

NOTE: The voltage in steps 10 and 11 should be between 19 Vac and 26 Vac with the Q3450 element glowing and the gas turned off. If the measured voltage is outside the acceptable range, analyze the appliance control system wiring, the input voltage supply, and the transformer to identify the problem. Correct the problem and retest the appliance.

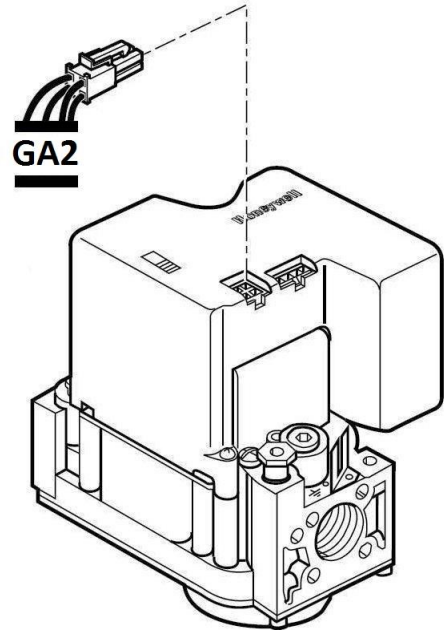

Figure 4

12. If the voltage is within the acceptable range, turn off the call for heat and make sure the measured
13. Voltage decreases to zero.
14. Disconnect the meter test leads from the GA1 Adapter.
15. Connect the meter test leads to the EFT output (BLUE wire) lead and the 24 Vac COMMON lead (GREEN wire) lead on the GA2 Adapter.
16. Turn on the gas supply.
17. Initiate a new call for heat.
18. When the appliance main burner lights, measure the voltage between the EFT OUTPUT LEAD (BLUE) and the 24 Vac COMMON LEAD (GREEN). This is a logic signal and can range from 15 Vac through 28 Vac.
19. Test is complete.
20. Turn off the appliance call for heat.
21. Disconnect the GA2 Adapter and meter test leads from the SmartValve™.
22. Reconnect the appliance wiring to the SmartValve™ .
23. Turn on call for heat and make sure the appliance works properly.

CAUTION: Electrical Shock or Equipment Damage Hazard. Can shock individuals or short equipment circuitry.

NOTE: The #GA2 is shipped with two parts.

- 1. The Test Harness which must be repaired using two butt connectors (not supplied).**
- 2. The Signal Converter.**

Test Adapter Set for Honeywell SmartValves™

The GA2 is a complete set of adapters and leads that allows a qualified technician to troubleshoot Honeywell's Gas SmartValve™ Series and replaces Honeywell's 395466 Testing Harness.

The GA2 consists of two components:

1. A repaired Test Harness, **Figure 5**, to be installed between the SmartValve™ and the pilot burner or HSI element/flame rod harness.
2. A Signal Converter, **Figure 6**, which allows measurement of the flame current in dc millivolts, mVdc, using a digital multimeter, Figure 2.

Read these instructions carefully before starting the tests procedures. Failure to follow these instructions can damage the meter, adapter and or gas valve and other connected components and may cause a hazardous condition.

3. Check the ratings given in the instructions and the specific gas valve to make sure the valve is the correct valve for the application.
4. After completing the measurements, use the appliance instructions to check for the proper operation as specified by the appliance manufacturer.
5. The GA2 will allow a trained, experienced service technician to determine the flame current levels being generated in a SmartValve™ System equipped gas-fired appliance.

Many things can influence the flame current being generated in an installed appliance. The ignition control generates a Vac voltage potential between the flame sensing rod and the burner ground. When flame is present, the shape of the flame rod and its ground combines with the voltage potential present to generate a low-level (microamperes) rectified dc current μAdc . The ignition control monitors this current to determine if a sufficient flame is present to operate the appliance. If the appliance does not generate a sufficient flame current, the main burner will not operate and the appliance will not deliver heat. If the flame current generated is unstable and fluctuates, there is high likelihood for inconsistent appliance operation. The service technician must insure that the appliance generates a strong and steady flame current well above the minimum threshold to assure reliable appliance operation.

Honeywell SmartValve™ Systems are available with two types of ignition:

1. Intermittent pilot models use a low voltage hot surface ignition (HSI) element to light the pilot gas; main burner gas flows and the main burner lights when the pilot flame is sensed.
2. Direct hot surface ignition models use a 120 volt hot surface ignition element to directly light main burner gas; if the main flame is sensed at the end of the trial for ignition, the main burner continues to fire.

Intermittent Pilot SmartValve™ Systems

Intermittent Pilot SmartValve™ Systems include: SV9401, SV9402, SV9403, SV9501, SV9502, SV9503, SV9601, SV9602, SV9440, SV9540, SV9541 and SV9640.

NOTE: Accurate pilot flame current measurement can be performed only with the pilot flame lit and the main flame not lit. When measuring with this adapter, the appliance main burner orifices should be

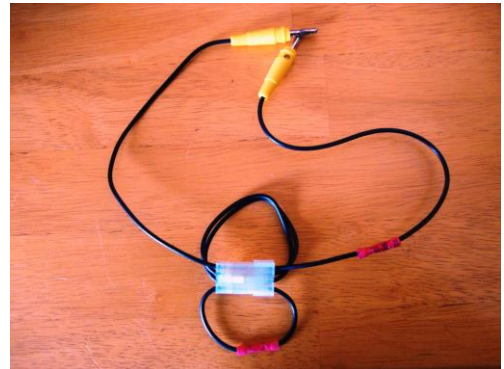

Figure 5



Figure 6

temporarily plugged while measuring system flame current. Be sure to remove the temporary plug and check the appliance for proper operation after completing the test.

Direct Measurement

Direct measurement requires a dc micro-ammeter, μA_{dc} , capable of reading to 0.01 microampere accuracy and a repaired Test Harness of the GA2, Figure 1. The Signal Converter, Figure 6, is not used.

1. Disconnect all power to the appliance.
2. Connect the GA2 between the valve control and the pilot burner.
3. Insert the meter plug connected to the valve side of the GA2 into the **mA terminal** on the meter.
4. Insert the other meter plug connected to the pilot burner side of the GA2 into the **COM terminal** on the meter.
5. Use the selector knob and set the meter to the μA range, then press the **DC/AC** key to select the measurement mode to dc, the LCD will display the current present.
6. Reconnect power to the appliance.
7. Generate a call for heat.
8. Make sure the pilot flame lights and the main burner does not light.
9. After the pilot flame is on for ten seconds, note the reading on the meter. The readings must be steady.
10. Take the action recommended in **Table 1**.

Millivolt Measurement

Millivolt measurement requires a voltmeter capable of reading dc millivolts mV_{dc} , and the Signal Converter portion of the GA2, see Figure 2.

NOTE: The Signal Converter is not polarity sensitive.

1. Disconnect all power to the appliance.
2. Connect the Signal Converter to the voltmeter.
3. Connect the Test Harness between the valve control and the pilot burner.
 - a. Insert the valve side of the Test Harness through the female end of the Signal Converter jack and into the **V/ Ω /Hz terminal** of the meter.
 - b. Insert the pilot burner side of the Test Harness through the female end of the Signal Converter jack and into the **COM terminal** of the meter.
4. Turn the selector knob to $\text{V}=\text{=}$ range.
5. Reconnect power to the appliance.
6. Generate a call for heat.
7. Make sure the pilot flame lights and the main burner does not light.
8. After the pilot flame is on for ten seconds, read the meter. The readings must be steady.
9. Take the action recommended in Table 1.

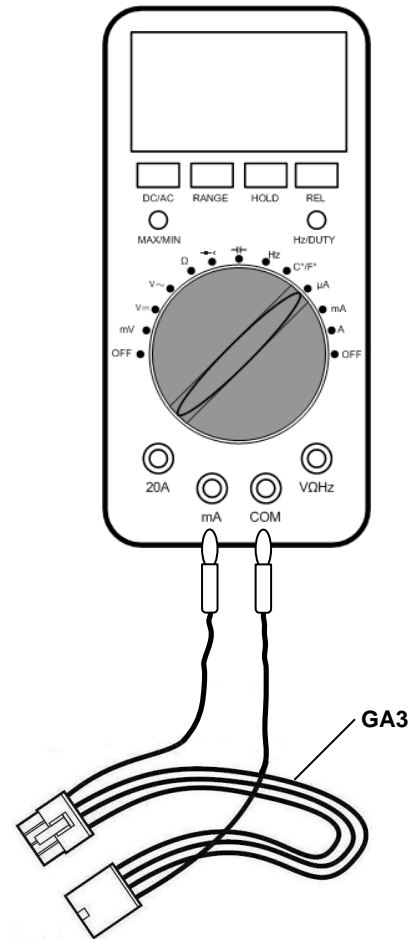

Figure 7

Measuring Main Burner Flame Current On 120 Volt Hot Surface Ignition Smartvalve® Systems

For 120 Volt Hot Surface Ignition (HSI) SmartValve® systems including SV9410, SV9420, SV9510, SV9520, SV9610, SV9620.

NOTE: Before measuring the flame current, check the appliance installation carefully to make sure that the 120 volt line input voltage polarity to the appliance control system is correct. Also, confirm that the appliance chassis is properly earth grounded and that the line voltage neutral wire is reliably connected to earth ground at the circuit box. The appliance will not operate properly if the electrical supply and earth ground are not correct.

WARNING: Read these instructions carefully. Failure to follow the instructions can damage the adapter, the meter or cause a hazardous condition.

1. Check the ratings given in the instructions and on the valve to make sure the valve is suitable for your application.
2. your application.
3. Serviceman/installer must be a trained, experienced (licensed) service technician, familiar with the sequence of operation of gas appliances.
4. After completing the measurements, use the appliance instructions to check the appliance operation.

IMPORTANT:

Accurate flame measurement can be performed only with the main burner flame lit after the ignition system trial for ignition has been completed. Trial for ignition is defined as the time that the main gas flows while the HSI element is hot. Typical trial for ignition times are five to nine seconds.

The appliance will then move to the RUN mode. If the main burner fails to light, flame current is not the problem. If the main burner lights but goes out at the end of the trial for ignition, recheck appliance power supply and ensure earth ground is present. Then check for other potential problems as directed in **Table 2**.

Direct Measurement

NOTE: Direct measurement requires an analog dc micro-ammeter capable of reading to 0.01 microampere accuracy. The Signal Converter is not required.

WARNING: Electrical Shock Hazard. Can cause serious injury, death or property damage. All direct ignition, hot surface ignition (HSI) SmartValve Systems have line voltage (120 Vac) present while the hot surface element is powered. Use extreme caution when the HSI element is energized.

1. Disconnect all power to the appliance.
2. Connect the Test Harness between the valve control socket, Figure 3, and the HSI element/flame rod.
 - a. Insert the male plug connected to the valve side of the Test Harness into the **mA terminal**.
 - b. Insert the other male plug connected to the HSI element/flame rod side of the Test Harness into the **COM terminal**.

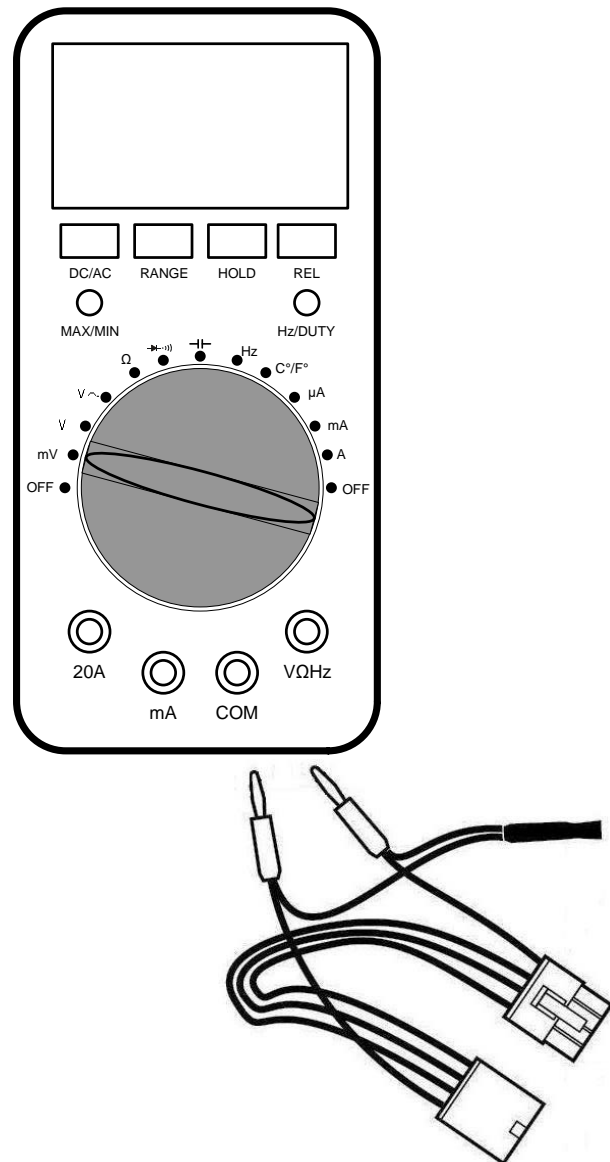

Figure 8

3. Use the selector knob and set to the μA range, press the **DC/AC** key to select the measurement mode to DC.
4. Reconnect power to the appliance.
5. Generate a call for heat.
6. Make sure the main burner lights and stays on after the trial for ignition ends.
7. After the main flame is on for ten seconds, read the dc micro-ammeter. The readings must be steady.
8. Take the action recommended in Table 2.

Millivolt Measurement

NOTE: Millivolt measurement requires a digital voltmeter capable of reading dc millivolts and the Signal Converter included with this kit.

1. Disconnect all power to the appliance.
2. Connect the Signal Converter to the voltmeter.
3. Set the voltmeter to read dc millivolts.
4. Connect the Test Harness between the valve control and the HSI element/flame rod.
 - a. Insert the valve side of the Test Harness through the female end of the Signal Converter connector and into the **V/ Ω /Hz terminal** of the meter.
 - b. Insert the HSI element/flame rod side of the Test Harness through the female end of the Signal Converter connector and into the **COM terminal** of the meter.
5. Turn the selector knob to $V\text{---}$ range.
6. Reconnect power to the appliance.
7. Generate a call for heat.
8. Make sure the main burner lights and stays lit.
9. After the main flame is on for ten seconds, read the meter. The readings must be steady.
10. Take the action recommended in Table 2.

CAUTION: Electrical Shock or Equipment Damage Hazard. Can shock individuals or short equipment circuitry.

Notes for Table 1 and Table 2

NOTE A

The SmartValve™ control is not likely to be the cause of low readings. Investigate the pilot burner location and gas supply. Also check for contamination on the flame sensing rod or ground strap, an obstructed or damaged pilot orifice, improper combustion air flow, poor electrical connections, loose or corroded pilot tubing, and damaged wiring.

NOTE B

A steady flame current reading at the required minimum levels mean there is enough flame current to open the main burner valve. A typical appliance, even under less than optimum operating conditions, should readily generate at least twice the required minimum flame current levels. If the pilot flame current generated by the appliance is less than twice the minimum reading, investigate further and take any necessary action.

Table 1
SmartValve™ Intermittent Pilot Flame Current

SmartValve™ Model	Meter Reading	System Status	Recommended Action
SV9500 SV9600	Less than 0.12 μ A or less than 12mV	Pilot lit, main valve not pulled in when pilot lights, the valve will click	Check the following: <ul style="list-style-type: none"> • Low inlet gas pressure • Flame rod contamination • Poor flame current path (including pilot tubing) • Pilot flame blown away from flame rod See Note A
	More than 0.12 μ A or more than 12mV		Replace control. See Note B
SV9401/SV9402/SV9403 SV9501/SV9502/SV9503 SV9601/SV9602	Less than 1.3 μ A or less than 130mV	Pilot lit, main valve not pulled in when pilot lights, the valve will click	Check the following: <ul style="list-style-type: none"> • Low inlet gas pressure • Flame rod contamination • Poor flame current path (including pilot tubing) • Pilot flame blown away from flame rod See Note A
	More than 1.3 μ A or more than 130mV		Replace control. See Note B
SV9440 SV9540 SV9541 SV9640	Less than 0.8 μ A or less than 80mV	Pilot lit, main valve not pulled in when pilot lights, the valve will click	Check the following: <ul style="list-style-type: none"> • Low inlet gas pressure • Flame rod contamination • Poor flame current path (including pilot tubing) • Pilot flame blown away from flame rod See Note A
	More than 0.8 μ A or more than 80mV		Replace control. See Note B

Table 2
SmartValve™ System Hot Surface Ignition (HSI) Flame Current

SmartValve™ Model	Meter Reading (10 seconds after main flame lights)	System Status	Recommended Action
SV9410 SV9420 SV9510 SV9520 SV9610 SV9620	NONE	Main flame does not light during trial for ignition	Check the following: <ul style="list-style-type: none"> • Gas supply off • Low inlet gas pressure • Excessive inlet gas pressure that keeps valve from opening • HSI element defective or broken • HSI not positioned properly • Main burner orifice(s) are wrong size See Note A
		Main flame lights but goes out at end of trial for ignition	Check the following: <ul style="list-style-type: none"> • Low inlet gas pressure • Line voltage polarity is reversed • Appliance is not grounded • Contaminated flame rod • Flame rod in wrong position • Flame sensor wiring is damaged • If all checks out, replace control
	Less than 1.1 microampere or less than 110mV	Main flame stays on after trial for ignition	Check the following: <ul style="list-style-type: none"> • Low inlet gas pressure • Contaminated flame rod • Flame rod in wrong position See Note B
	More than 1.1 microampere or more than 110mV		See Note A

FIREDRAGON Field Notes © REPAIR of the GA3 Test Harness Adapter

To complete the field repair of the GA3 Test Harness obtain two each standard 18-22 butt connectors.

1. Remove the Test Harness from the bag, **Figure A**.
2. Remove the Signal Converter (RED LEADS and CONNECTORS) from the Test Harness, **Figure B** and place the Signal Converter aside. It is correct and needs no repair.
3. Plug the two end connectors of the Test Harness together and make sure the Molex connector lock is facing you and to the left, **Figure C**.
4. Cut the wire that runs from the left bottom to the top right of the Molex connector, **Figure D**.
5. Now cut the wire that runs from the bottom right of the Molex connector to the yellow plug, **Figure D**.
6. Take the two bottom wires in the Molex connector and butt splice them together, **Figure E**.
7. Take the wire now leaving the top right of the Molex connector and butt splice it to the wire ending in the yellow plug, **Figure E**, completing the repair. The Test Harness is now ready for use.



Figure A



Figure B

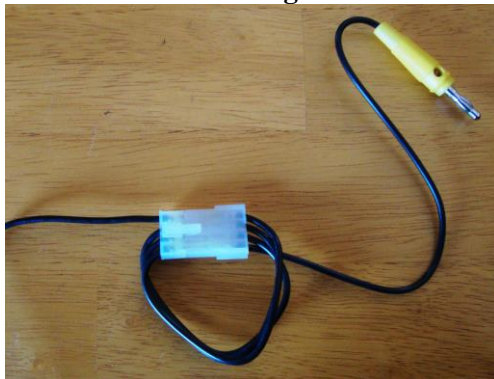

Figure C

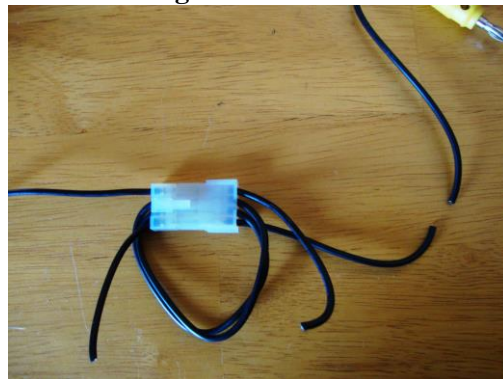

Figure D

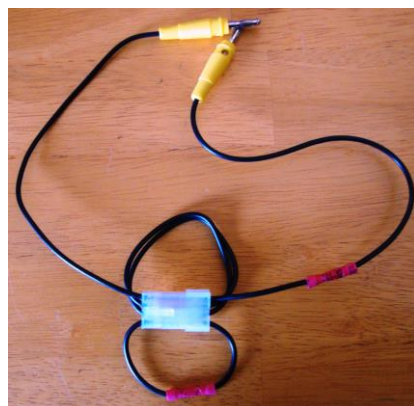

Figure E