



## **Scrambler**

### **Valve Measurement and Adjustment User Guide**

**Contents**

Introduction .....3

Operation .....3

Checking Valve Clearances .....4

Remove the Spark Plugs .....4

Opening Shim Clearance Measurement.....6

Closing Shim Clearance Measurement.....6

Determine if valves are within specification.....7

Opening Shim Removal, Measurement, Replacement.....7

    Measure .....8

    Record.....8

Closing Shim Removal and Measurement.....8

    Measure .....9

    Reassembly.....10

Appendix 1 – Ducati Scrambler Valve Measurement Recording Sheet .....11

## Introduction



The Scrambler engine is an updated version of Ducati's classic SOHC V-twin. It is an air-and-oil cooled two-valve engine displacing 803cc. The valve service intervals are more frequent with the air/oil cooled engines; therefore the Scrambler Valve Adjustment Intervals are 7500 miles.

The shims don't wear as much as the valve seats do. As the engine is run, the face of the valves and seats wear as they bed into each other (opener clearances get smaller and the closer clearances get bigger). The result is opening and closing clearances that change with use.

Bringing the valve clearances into factory specifications assures the best possible performance of from your scrambler.

## Operation

The Desmodromic (Desmo) engines use a positive valve control system to open and close the valves at the same time in the combustion cycle regardless of RPM. The Desmo valve system uses an opening rocker arm and a closing rocker arm that press on shims attached to the valve stem to open and close the valve in a precisely controlled manner: as the components wear, the gap (clearance) between the rocker and the shim changes. To compensate for these naturally occurring changes, the shims are replaced with thicker/thinner shims to bring the gap back into specification.

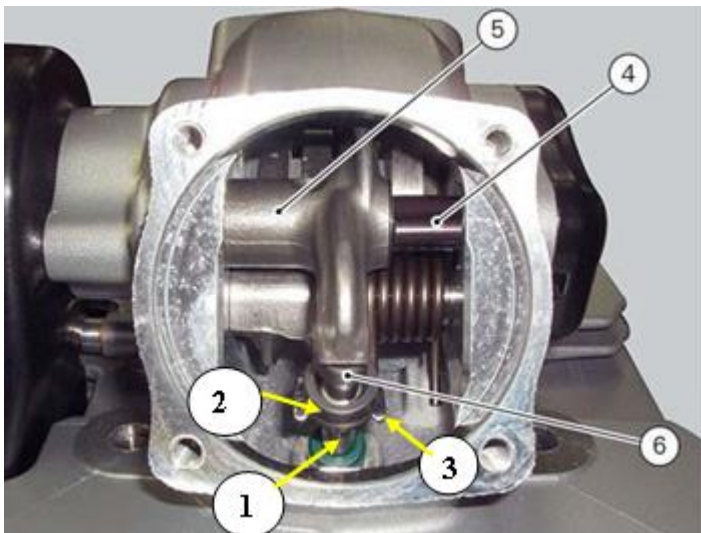

1. Valve
2. Closing Shim
3. Closing Rocker Arm
4. Retaining Clip
5. Opening Rocker Arm
6. Opening Shim

## Checking Valve Clearances

Before the clearances can be checked there is some disassembly required. Try and have as little fuel as possible in the gas tank before beginning this procedure. It is easiest to measure all the clearances prior to disassembling the valve train to replace the shims.

1. Place the motorcycle on a swing arm stand, transmission in neutral.
2. Remove the seat.
3. Remove the fuel tank.
4. Remove the blow-by (part of the air box)
5. Remove the following components from the electrical component box:
  - a. Battery
  - b. Starter Relay
  - c. Fuse box
6. Remove the cylinder head valve covers (1), be careful if not replacing the gaskets with new ones

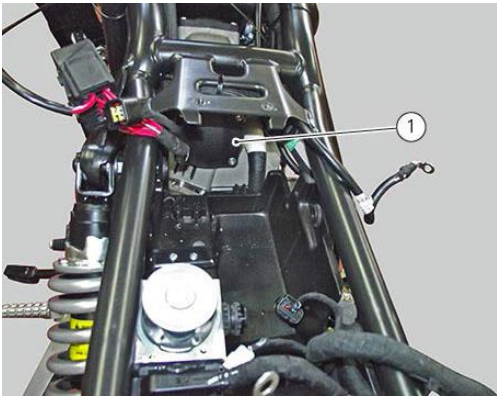

Vertical Cylinder



Vertical Cylinder

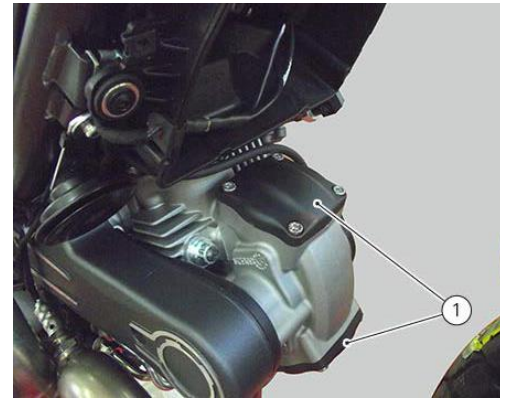

Horizontal Cylinder

## Remove the Spark Plugs

Remove the spark plug boots (1) and the spark plugs (2) from the horizontal and vertical cylinders.

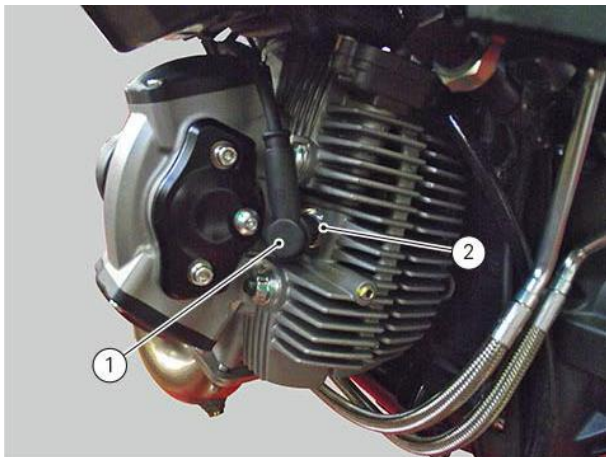



Working from vehicle left-hand side, loosen the two screws (3) and remove plug (1) from generator cover (2)

Once the plug is removed from the generator cover, install the engine turning tool, making sure the **fangs** on the tool engage the indents on the crank shaft (4).



Tighten the retaining bolt snug with a 13 mm wrench.

With the sparkplugs removed rotate the engine turning tool counter clockwise (from the left side of the engine) until the horizontal cylinder comes to the top of its stroke: Top Dead Center (TDC).

TDC occurs at the top of the compression stroke. You can feel air rushing out of the cylinder as the piston comes up on the compression stroke. The magnet gently inserted into the cylinder will give a visual indication when the piston has reached the top of the stroke. (The handle of the engine turning tool will be in line with the horizontal cylinder)

**IMPORTANT:** With the horizontal cylinder at TDC, the engine is in the "HOME" position. The HOME position is the condition where all of the timing marks will align (useful for belt changes).

The horizontal cylinder is also in the "rest" position (no tension on the valves). The "rest" position is the correct position to measure the valve clearances. Verify the rest position by spinning the opening shim with your finger.

## OPENING SHIM CLEARANCE MEASUREMENT



With the valve in the “rest” position, slide the feeler gauge between the opening rocker arm and the opening shim. Begin measuring using a thin gauge, ~ .05mm; proceed using thicker/thinner gauges until the gap can be determined. The correct feeling is one of slight resistance, similar to the feeling of inserting the gauge into a large book and moving it between the pages.

Measure the valve clearances for both the intake valve (middle of the “vee,) and the exhaust side (where the exhaust exits the cylinder head).

Record measurements in APPENDIX 1.

## CLOSING SHIM CLEARANCE MEASUREMENT



Once the opening clearances have been measured, measure and record the closing clearances.

Slide a feeler gauge between the closing rocker arm and the closing shim to measure the clearance.

Record your measurements in APPENDIX 1.

The clearances for the horizontal cylinder have been measured.

The clearances for the horizontal

### Repeat the measurements for the vertical cylinder:

Slowly rotate the engine turning tool counter clockwise 270 degrees to bring the vertical cylinder to top dead center. When the vertical cylinder is on the compression stroke, the air will rush out of the cylinder; a thumb or finger lightly covering the spark plug hole is a good way to feel the air rushing out. Using the magnet and slight adjustments with the engine turning tool, you will quickly locate the TDC of the vertical cylinder. Repeat the measurements for the opening and closing clearances and record those readings in APPENDIX 1.

## Determine if valves are within specification.

Determine if the clearances are within specification by comparing the measurements you recorded to the Factory Specification. Any measurement that exceeds Factory Specified Clearance will require changing a shim to bring the clearance back into Factory Specification. The basic sequence is:

1. Look at the values you measured and recorded in (Column A) APPENDIX 1. Note which measured clearances exceed the Factory Specified Clearance (Column B).
2. Subtract the lowest Factory Specification (.1 for intake, .0 for exhaust) from your measurement and record that number in Column C.
3. Measure the existing shim and record this number in Column D.
4. Add Columns C and D in order to determine the size of the new shim to bring the clearances back into specification. Note, it is not always possible to get the exact shim size. A larger shim can be made to the correct size using emery paper or 400 grit wet/dry sandpaper to adjust the size of the shim.

Refer to the following sections for shim removal, measurement, and replacement. Remember to place the cylinder being worked on at TDC for ease of shim removal (no tension on the valve/shims).

Refer to Appendix 1.

## Opening Shim Removal, Measurement, Replacement

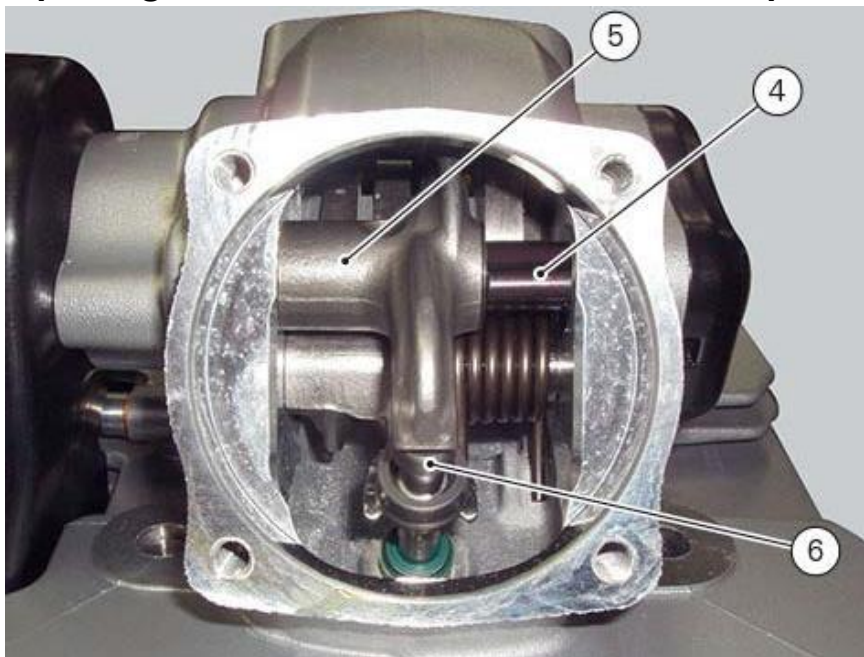

If either the opening or the closing shims require replacement to bring the gap(s) into specification follow this procedure.

Pry off the spring clip (4) from the rocker shaft.

**WARNING**, this clip will fly into your eye or to parts unknown if it isn't restrained.

Note: be sure to

segregate and mark all pieces/parts removed so there is no question on reassembly.

Once the clip is removed the opening rocker (5) will need to be slid out of the way to access the opening shim. This will take some wiggling/working the cams back and forth to get the opening rocker to slide. If the cam belts are removed, wiggle the cam gear to get the rocker to slide off. If the cam belts are still in place, use the engine turning tool to wiggle the shaft and release the opening rocker to slide to the side (arrow).



Remove the Opening shim (6) from the valve stem.

### Measure

NOTE: The Opening Shim has a Flat side and a recessed side. Using light pressure, close the dial caliper all the way and “zero” the unit: hold the On/Off/Set button until all Zeros appear in the display.

Open the Caliper sufficiently to allow the Opening Shim to fit between the jaws of the micrometer. The flat side of the Opening Shim should rest against the stationary jaw of the micrometer. The moveable portion of the micrometer will fit inside the recessed portion of the opening shim.



### Record

Record the measurements in Appendix 1.

### Closing Shim Removal and Measurement

If the closing shim needs replacement, remove the opening shim as described in the previous section. The valve stem is exposed with the opening rocker slid to the side.



Place a clamp on the valve. In addition to having the cylinder at TDC, this is a little extra insurance to keep the valve from dropping into the cylinder.



Press down on the Closing rocker to expose the retaining rings. Slight engine rotation may be required to get the rocker to move far enough to expose the retaining rings. The retaining rings are in two halves.





Use the magnet or magnet end of the screwdriver to extract both halves of the retaining rings and set aside in a very safe place (a zip lock bag properly labelled with the valve the rings belong to).



With the retaining rings removed, you can now slide the closing shim up and off the valve stem. If the shim gets "stuck" at the top of the valve stem, it is an indication the valve stem has mushroomed a bit. Some emery cloth/sandpaper is needed to remove the wide part at the top of the valve stem to provide clearance for the shim to slide off.

## Measure



The valve shim measuring tool and the electronic caliper will be used to take the measurement. The tool sets inside of the closing shim and gives a standard 10mm addition to your measurement.



Turn the caliper on. Close the jaws using light pressure. Select the unit of measure: either inch or mm. The shims are designated by Ducati in millimeters and using mm as the unit of measure simplifies new shim size selection. Press ZERO to set the base line for the caliper.



Place the Shim Measuring Tool inside the closing shim (narrow end in) and measure the overall length.

REMEMBER- The TOOL adds 10mm to the measurement: subtract 10mm from the measurement and record your number in Appendix 1.

In this example, the closing shim size would be 6.57mm.

## Reassembly

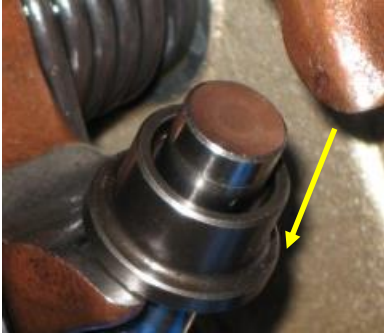

Obtain the correct shim(s) and reassemble the valve train. Slide the closing shim onto the valve stem. The wider side slides onto the valve stem first.

Depress the closing rocker and install the half rings (retaining rings). Do this with your finger or dip the end of the screwdriver in a little oil and use the screwdriver to install the half rings.

While depressing the closing rocker, set a half ring in place on the valve stem. Rotate this ring around to the back side of the valve stem to leave room for the other half ring. Install the other half ring and slowly release the pressure from the closing rocker, making sure the half-rings sit onto the valve stem correctly.

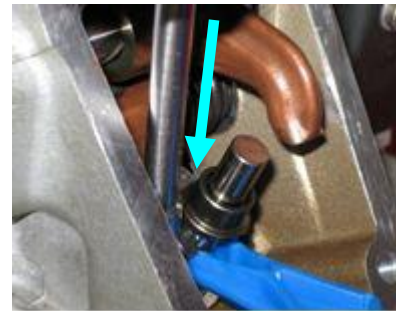

Put Opening shim onto valve stem

Once installed, slide the opening rocker over the opening shim.

REMEMBER, you will have to wiggle the cam (belts removed) or the motor using the Engine rotating tool (belts installed) to get the cams in position to slide the rocker over the valve.



Once the rocker is in place, press the spring clip into place. Some firm pressure will be required.

Once the valve is reassembled, re-check the clearances to verify the valve train is within specification. With the cam belts installed, rotate the engine to verify smooth operation. Reassemble as required.

## Appendix 1 – Ducati Scrambler Valve Measurement Recording Sheet

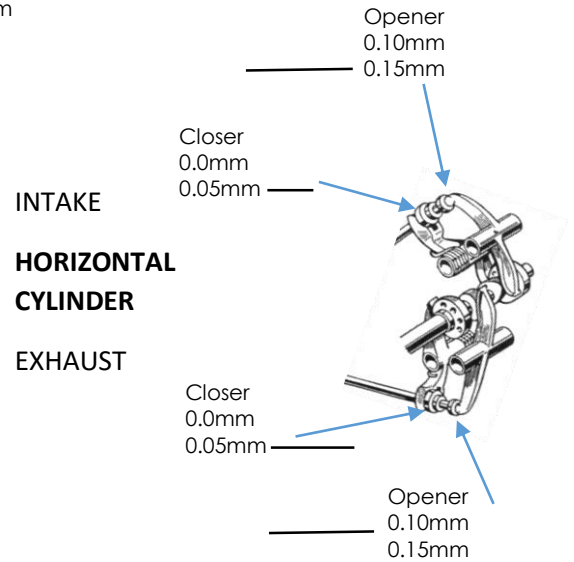
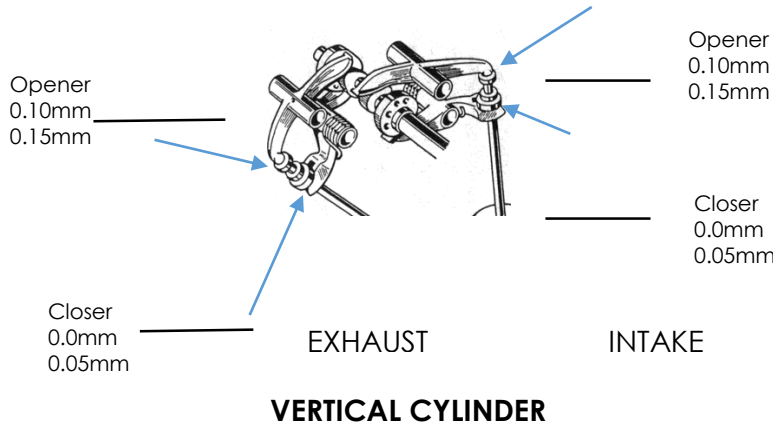

If there is a clearance out of specification, that is the gap is larger than the Ducati Specified Clearance there is a little calculation to figure out the new shim size to bring the gap back into spec.

- Record the measured clearance in the column A.
- Subtract the Ducati Specified clearance, column B, (use .10mm for Openers and .00 for Closers). Record the result in column C.
- Remove the existing shim and measure. Record this number in column D.
- Add columns C and D together and you will have the new shim size.
- Shims come in .05mm increments. If the new shim size you calculate is between shims available in the kit, you may have to use 400 grit wet/dry sandpaper and sand a larger shim into the perfect size.

		A		B		C		D		E	
		MEASURED CLEARANCE		DUCATI SPECIFIED CLEARANCE		NUMBER TO BE ADDED TO SHIM		SHIM MEASUREMENT		NEW SHIM SIZE	
HORIZONTAL CYLINDER	INTAKE	OPENER	-	.10 - .15mm	=		+		=		
		CLOSER	-	.00 - .05mm	=		+		=		
	EXHAUST	OPENER	-	.10 - .15mm	=		+		=		
		CLOSER	-	.00 - .05mm	=		+		=		
	VERTICAL CYLINDER	INTAKE	OPENER	-	.10 - .15mm	=		+		=	
			CLOSER	-	.00 - .05mm	=		+		=	
EXHAUST		OPENER	-	.10 - .15mm	=		+		=		
		CLOSER	-	.00 - .05mm	=		+		=		