

SHADYBOWL SPEEDWAY 2019
WOOTEN AUTOMOTIVE AND TOWING MODIFIED RULES

IT IS UP TO YOU AS A DRIVER OR CAR OWNER TO FOLLOW THESE RULES AND COMPLY WITH THEM AT ALL TIMES AS WE (SHADYBOWL SPEEDWAY) RESERVE THE RIGHT TO TECH ANY CAR AT ANY TIME ON THE PREMISES. FAILURE TO COMPLY WILL RESULT IN PENALTIES/DISQUALIFICATIONS/LOSS OF POINTS AND MONEY. IF SOMETHING IS NOT LISTED HERE IN THE RULES DOES NOT MEAN IT'S LEGAL. **INSPECTION EQUIPMENT USED BY AN OFFICIAL WILL BE THE STANDARD OF THE RACE TRACK AND ALL TESTS WILL BE FINAL. ALTERING OF A MANUFACTURING PART NUMBER WILL NOT BE PERMITTED. ANY PART FOUND WITH ALTERED PART NUMBERS WILL BE DISALLOWED IN COMPETITION. (EXAMPLE: SPRINGS AND SHOCKS MUST MAINTAIN ORIGINAL COLOR BY MANUFACTURER, CAN NOT REPAINT ANY SPRINGS OR SHOCKS.)**

OWNER/DRIVER MUST MAKE SURE THEIR EQUIPMENT (SPRINGS AND SHOCKS, ETC.) MEETS THE STANDARDS SET FORTH ON THE TRACKS TEST EQUIPMENT.

ATTENTION MOD DRIVERS - If needed 6" body rake will be measured at a 4" ride height.

11" motor height will be measured at a 4" ride height.

Minimum Oil Pan depth 6 1/2"

1. FRAME: 1964 or newer OEM perimeter American made rear wheel drive passenger car frame only. No sports car frames. No strut front suspension of any kind allowed. Square tube front clips will be allowed but must be square tube chassis/clips UNALTERED Howe part # 358-09 OR Howe part # 358-10 2x4 or 3x4 only at this time. Frame cannot be widened or narrowed. Exceptions: Weight jack in original center line of spring tower; frame may be cut a maximum 36 inches forward from center of rear housing; horns may be removed in front of steering box; front cross member may be notched and boxed for radiator and/or steering clearance but not raised; maximum 7 inch wide opening in side of spring tower for spring removal. OEM upper A mounts may be replaced with aftermarket mounts. Minimum wheelbase 108 inches, maximum 112 inches, both sides. Maximum overall width, front and rear, shall not exceed 78 inches from outside of tire, to outside of tire. No part of frame or body shall be lower than 4 inches from ground, except the front cross member, in race trim. Left side frame rail must run to interior footbox.

2. ROLL CAGE: Must consist of continuous hoops, minimum 1.75 inch O.D. tubing, with a minimum wall thickness of .095 inch for the main cage. Frame mounted in at least 6 places, low carbon or mild steel recommended. Must consist of a configuration of front, rear, and top hoops connected by tubing on the sides or side hoops. Driver's head must not protrude outside cage with helmet on. Roll cage must be securely supported and braced with minimum 1 cross bar in top halo.

Foot protection bar(s) required. Main cage no further forward than rear of engine. All bars forward of the cage must be lower than the hood

3. DOOR BARS: All driver side door bars and uprights must be a minimum 1.75 inch and .095 inch wall thickness. Minimum 4 driver side door bars, parallel to the ground and perpendicular to the driver, and welded to the front and rear roll cage. Passenger side must have at least 1 cross door bar, horizontal or angled, and 1 top door bar, minimum 1.5 inch O.D. Steel door plate, 16 gauge (.065) minimum thickness,

must be securely welded to outside of the driver side door bars and cover the area from top door bar to bottom door bar and from rear hoop down post to front cage down post.

4. FRONT SUSPENSION: All components must be steel, unaltered OEM, in OEM location, and replaceable by OEM parts. Exceptions: Tube type upper A frames with or without aluminum or steel cross shaft, and mounts can be moved; stamped steel OEM replacement lower a-frames; rubber, nylon, or steel lower a-frame bushings; no offset bushings; welded or bolted shock mounts on lower a-frames. Lower a-frames must be right and left, and of the same design. "NO MANIPULATION" of lower a-frame mounts and bolt holes on frame must be in OEM location, "NO MANIPULATION". OEM TYPE BALL JOINTS ONLY. Sway bar must be OEM type, no splined bars.

5. STEERING: No rack and pinion. All components must be steel, unaltered OEM, in OEM location. Exceptions: tie rod ends and adjuster sleeves may be replaced by a minimum .625 inch steel rod ends and steel tubes; OEM spindles can be modified for ball joints and tie rod ends; passenger car drop spindles allowed; (NO MADE FOR RACING OR FABRICATED SPINDLES.) Bolt on spindle savers allowed; spindles must be right and left, and of the same design; steel steering shafts and knuckles only; steering quickener, steering wheel and quick release may be aluminum; driver compartment steering may be modified, but must be kept on left side. OEM center link or OEM after market type center links allowed. After market center links could be phased out in the future.

6.. SPRINGS (FRONT) : Steel coil springs only. Coil springs right front 650# minimum, left front 600# minimum. Spring heights minimum 10". 5" diameter minimum. NO tender/ progressive rate springs. NO take up springs of any kind. 1 spring per wheel only. All springs must be visible/NO covers. No torsion bars or air bags. ONE SPRING RUBBER PER SPRING. (NO COIL BINDING)

7. SPRINGS (REAR): Steel coil springs and leaf springs allowed. Coil springs must be at least 5" diameter. Spring heights minimum 10". Steel coil over eliminators, and steel or aluminum (5") coil over kits allowed on the rear only. Must conform to shock and spring rules. ONE SPRING RUBBER PER SPRING. (NO COIL BINDING) No spring preloaders.

8. SWAY BAR: OEM style only maximum size 1 1/8. NO splined ends.

9. REAR SUSPENSION: No independent rear suspension. All components must be steel. No covers allowed. All trailing arms/link bars must be made of steel tubing. Rear of frame may be altered to accept leaf or coil springs. Pull bar may utilize smaller O.D. spring. One (1) mechanical traction bar only. No rear sway bars. Aluminum panhard bar adjuster allowed. No bird cage type suspensions or multiple mounting points, wish bone, 4 link, or any active system is NOT allowed. Race track reserves ALL rights to approve/disapprove any system.

10. SHOCKS: Steel, factory sealed, non rebuildable. Pro WB series or AFKO #14 series only! Rates 3 through 5 50/50 valving. NO split valve shocks. 7" or 9" lengths allowed. Right front shock must be heaviest rate. One (1) shock per wheel, with one (1) additional shock allowed in the lift / pull bar area. No air shocks. No shock covers. No chassis limiting devices..example..frame stops, frame extensions. Absolutely No bump stops. Fine for limiting devices will be the same as shock altering.

SHOCK CLAIM: SHOCKS CAN BE CLAIMED BY RACE TRACK OR ANY OTHER DRIVER FINISHING IN THE TOP 5 IN COMPETITION IN THIS CLASS THAT NIGHT FOR \$90.00 PER SHOCK.

NO SALE PENALTY: \$250.00 FINE. LOSS OF POINTS AND MONEY THAT NIGHT. CAN NOT COMPETE IN THE FOLLOWING 2 RACES.

ALTERING SHOCKS: 1ST OFFENSE..\$250.00 FINE PLUS CAN NOT COMPETE IN FOLLOWING 2 RACES.

2ND OFFENSE...\$1000.00

FINE PLUS 1 YEAR SUSPENSION FROM COMPETITION.

11. REAR END: LOCKED DIFFERENTIALS ONLY. NO traction style differentials allowed. Examples.. Gold/Black track, Gleason, Detroit locker, But not limited to names listed. Any steel approved OEM passenger car or truck rear end allowed. Closed, steel tube Quick changes allowed. Safety hubs (floater) mandatory. Steel axles only. No cambered rear ends. One (1) piece drive flange only. All components must be steel. Exceptions:lowering blocks, axle caps, rotor plates, and drive flanges. No aluminum hubs permitted.

12. BODIES: Body must be same width front to rear and parallel to the OEM frame. Bodies on both sides must not extend no further forward than the rear of the engine block. Fabricated body parts may be made of steel/ aluminum/ fiberglass (no carbon fiber or plastic) with the exception of Howe part #'s 622 & 624 along with the MD3 plastic nose piece #020-410 (available through Performance Bodies and Five Star Bodies) They are the only approved plastic body parts. Engine compartment must remain open on both sides. No panel in front of right door to engine compartment. No inner panels. Hood sides may have up to a maximum of 6 inch drop and must be enclosed to front firewall. Hood also may have up to a maximum 6 inch rake from front back to firewall. (known as a Bice car or Stacy car nose) Driver and Passenger windows must have at least 12 x 18 inch opening. (height and width) measured at center of window between lowest point at top of window whether roof or roll cage, and the highest point at bottom of window whether interior or body. Must have front windshield support and rear window support post. (painted roll bars are not acceptable) No wings or aerodynamic devices inside, outside or under the car. Outside of tires must be the widest part of car. Body sides must remain perpendicular and not be flared out. Body width should be the same at the top and bottom of the panels. Quarter panels and b/c pillars (sail panels) must be 2 distinct pieces. Sail panel design must match from side to side. Use of lexan in sail panels are permitted. You may run a lip (maximum 3/4" x 3/4" on sail panels) Sail panels must be on a single plane (not concave or convex) Oil coolers/ radiator must not protrude above interior or outside of body. TOP OF QUARTER PANELS AND TOP OF DOORS: Where body joins together you may bend it at a straight 90 degree bend. You may round it off, or join together flat with a maximum 1/2 inch lip. ROOF: Roof must be made of a single material aluminum or fiberglass only. (NO multi material or multi layered roofs, NO carbon fiber) Roof must be full size, rounded and stock appearing, convex from side to side, and front to rear. (NO flat or concaved roofs) Roof panel can be no higher than 4 inches above top of roll cage. NOSES: On the aluminum or any nose you must run full upper and lower nose. You may run a maximum 1.50 inch lip on the top sides of nose, and 3 inches around the bottom of nose. NO portion of nose will protrude past front edge of bumper or will be lower than the 4 inch ride height. ANY BODY DEEMED TO BE TOO RADICAL OR NOT IN COMPLIANCE WITH THESE RULES WILL ADD A MINIMUM OF 100 POUNDS OF WEIGHT (LOCATION OF OFFICIALS CHOICE) PLUS WILL RACE FOR 75 % OF PAYOUT FOR FINISHING POSITION AND 50 % OF POINTS EARNED FOR THAT RACE UNTIL BODY IS BROUGHT INTO COMPLIANCE.

13.. DRIVER COMPARTMENT: Must have a minimum 3 windshield bars in front of the driver. (NO full windshields) Lexan or aluminum cowl panel in front of the driver can be no wider than the cockpit and no farther back than the steering wheel. Minimum .125 inch aluminum, or 22 (.035 inch) gauge steel, complete floor pan required. Aluminum high back seat only and must be bolted in securely, inside the left

OEM frame and ahead of the rear tires. Bottom of seat can be no lower than bottom of frame. (NASCAR style right and left head, shoulder supports and leg restraints highly recommended). Driver must be sealed off from track, driveline, engine, fuel cell, battery and pumps. No driver adjustable devices allowed in cockpit except brake adjusters.

13A. MIRRORS/RADIOS: No mirrors and/or two way radios are not permitted in the car or in the driver's equipment. All divisions must have a RACEceiver radio system.

14. SAFETY EQUIPMENT: Snell-rated SA2010 helmet required. Roll bar padding required in drivers compartment (Fire retardant highly recommended). SFI full fire suit required. Fire retardant neck brace, gloves and shoes required. (Fire retardant head sock and underwear; head and neck restraints; collapsible steering shaft; highly recommended). Driver side window net required, and must be mounted so that the latch is at the top front of window. Minimum three inch wide, five point safety belt assembly required, must be mounted securely to the role cage and must be less than 3 years old. Fire extinguisher required. Kill switch required within easy reach of driver and must be marked 'OFF' and 'ON'.

15. BUMPERS: (See diagram) NO variations from this will be permitted. Steel bumpers must be on front and rear at all times and welded or bolted securely to the frame. Must be a minimum 1.25 inch O.D. tubing, .065 wall thickness. Two bar front bumper must be mounted frame end to frame end, no wider than width of OEM frame horns. Bottom loop must be parallel to the ground. Top bar must be directly above bottom bar, minimum 6.5 inches apart, measured center to center. Aluminum I-beam rear bumper are allowed. No sharp edges.

16. WHEELS: Eight (8) inch steel wheel only, measured from inside bead to inside bead. No bead locks, screws, or rim mounted bleeder valves. Steel and aluminum wheel spacers are allowed.

17. TIRES: American Racing Tires (purchased at the track). No softening, soaking, conditioning, siping, or grooving of tires. No re-caps. Soaking of tires is strictly prohibited. (This rule applies to ALL tires in the pits, on the car, in the trailer or hauler, ALL tires) Tires may be checked at any time. **All race tires MUST have baby powder in them. After feature the top 3 finishers may be asked to break down one (1) or two (2) to check for powder.**

One (1) new tire per night of racing. ALL TIRES WILL BE BRANDED!!!

18. BRAKES: Must be steel OEM type, operative on all 4 wheels, drum or disc. Must maintain minimum OEM dimensions for hub/rotor and calipers, cannot be drilled or lightened. Bolt pattern may be changed. Larger studs allowed. Rear rotors may be aftermarket, minimum .810 inch thick, vented rotors only. No aluminum hubs. No scalloped or drilled rotors.

19. EXHAUST: Round tube headers only. All primary tubes must enter into 1 collector, at the end of the header. Mufflers required. Right side exhaust must exit under the car (not out right side door).

20. FUEL SYSTEM: Mechanical or belt driven pump only and must be mounted on front of motor. Racing fuel cell required 22 gallon maximum capacity, square or rectangle in shape (no tear drop, wedge, or exotic F-1 type fuel cells allowed). Must be in a minimum 22 gauge steel container. Cell must be securely mounted behind the rear axles and between the rear tires. Cell must be no lower than bottom of rear end housing. Cell must be mounted with a minimum 2 solid steel strap around the entire cell, 2 inches wide and .125 inches thick or equivalent. All cell mounts must be steel and securely welded or bolted to the frame. Protective tubing must cover rear of cell and extend past both ends of the cell. No part of the cell is

to be lower than the protective tubing. Vents and lids must have check valves. Fuel line pick up must be on top of cell. No cool cans and (1) fuel filter only.

21. FUEL: Racing gasoline, no alcohol allowed.

22. WEIGHT: Minimum weight limit of 2,400 pounds, 58% left side weight (No Tolerance), after race with driver and helmet in car setting in normal driving position. Weights must be securely mounted with at least (2) half inch bolts to frame or roll cage, and painted white with car number on it. No weight outside of the body. No titanium, carbon fiber, or exotic materials used on race car. No gun-drilled, tubular, hollow bolts or studs. Steel fasteners only.

23. BATTERY / STARTER: One 12/16 volt battery only, must be securely mounted between frame rails, behind cross member, in front of rear end and outside of driver cockpit, with positive terminal covered. Car must have the capacity of starting without being pushed or pulled. Standard or reverse mount starters allowed.

24. GAUGES / ELECTRONICS: No electronic monitoring computer devices capable of storing or transmitting information. Exception: Analog tach. No adjustable ignition control boxes. One (1) 12/16 volt ignition box allowed, with rev chip, must be out of reach of driver. No additional ignition accessories allowed. No magnetos. No traction control devices.

25. TRANSMISSION: Must have at least two forward gears and one reverse, plus a neutral position. With engine running and car in still position, must be able to engage car in gear and move forward, then backward. OEM production type or approved aftermarket transmissions (Bert, Brinn, Falcon) allowed. (2-speed, 3-speed, 4-speed and automatic). No 5-speed or more transmissions, No 'in and

'out boxes allowed. Standard clutch type transmissions must have a blow proof bell housing (steel or aluminum). Automatic transmissions must have an approved scatter shield.

26. DRIVE SHAFT: Minimum 2.5 inch diameter, steel drive shaft, painted white. Steel slip-yokes only. 360 degree drive shaft loop required and must be constructed of at least .25 inch by 2 inch steel or equivalent, mounted 6 inches back from front u-joint.

27. ENGINE COMPARTMENT: Rear of engine must be mounted at least 72 inches forward from centerline of rear axle. Engine offset must be kept within 2 inches of centerline of front cross member with engine level. Minimum 11 inches from centerline of crank shaft to ground. Radiator must be mounted in front of engine. Cooling system may be modified. No anti-freeze.

28. ENGINE: Any American make engine allowed. Steel block. No machine work to the outside of block (lighting). Wet sump oiling system only. Minimum 6 1/2" Oil Pan. One (1) naturally aspirated two or four barrel carburetor only. (No fuel injection) No magnetos. No external oil pumps. Intake must be steel or aluminum.

29. NUMBERS / DECALS: All numbers shall be in contrasting color from body, affixed to both doors and top, be at least 4 inches thick and 20 inches tall, and be readable from the passenger side of car. Competitors are to reserve the front 24 inches of each door and the first 6 inches of the roof for Sanctioning Body and/or Track Sponsors.

ASPHALT BODY DIAGRAM & DIMENSIONS (DIAGRAM PICTURED BELOW)

(A)20" Max. – 16" Min. (Ground to center of bumper front & rear)

(B)6.5" Min. (Center to center)

(C)52" Max. – 42"Min.

(D)6" Max. Hood sides – 3" Max. Rake in hood.

(E)32" Max. (Bumper & Nose)

(F)6" Max. (Scoop/Deflector)

(G)4" Min. at Nose and Sides– 8" Min. at Quarters

(H)19" Max. (Same both sides)

(I)112" Max. – 108" Min.

(J)29" Max. – 22" Min.

(K)72" Max. Or not past back of block, right side. Left side may extend forward to cover foot box if necessary.

(L)18" Max. – 12" Min. Opening, both sides.

(M)With 4' level, must have 2" gradual clearance at rear and no more than 5" at front

(N)120" Max. – 106" Min.

(O)45" Max. – 34" Min.

(P)3" Max. height at rear of sail panel, gradual slope from roof to this point.

(4" x 66" Max. spoiler allowed with supports to the rear only.)

(Q)Interior slope is 6" Maximum. Front to rear and flat across. If flat at front half of interior you have used up 50% of your 6" so from behind the driver to the rear you only have 3" of slope. Top of interior must be flush with top of doors and quarter panels.

(R)38" Max. – 28" Min.

(S)38" Max. – 24" Min.

(T)66" Max. – 24" Min. No narrower than radiator

(U)52" Max. – 44" Min.

(V)56" Max. – 41" Min.

(W)Tires must be the widest part of the car. Must be able to see side wall of tire from front, top, and rear.

(X)66" Max. – 53" Min.

(Y)8" Panel / 90 degrees to ground. Must be solid, attached to the deck and extend to the quarter panels, securely fastened.

(Z) Aluminum "I" beam or tubular steel rear bumpers allowed, must have rounded nerf bars that follow quarter panel and connect back to frame on both sides.

Rules are subject to change. Any part found illegal will be confiscated by track officials and remain track property

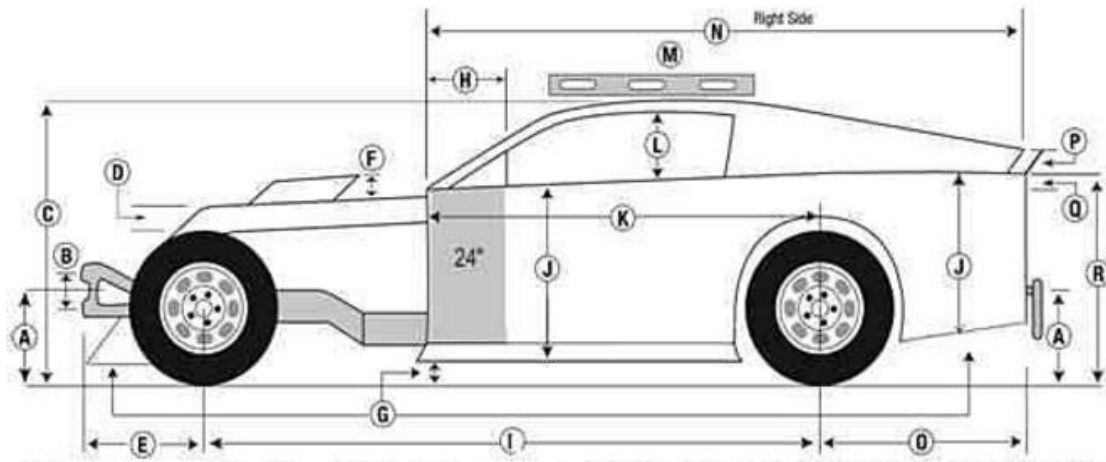

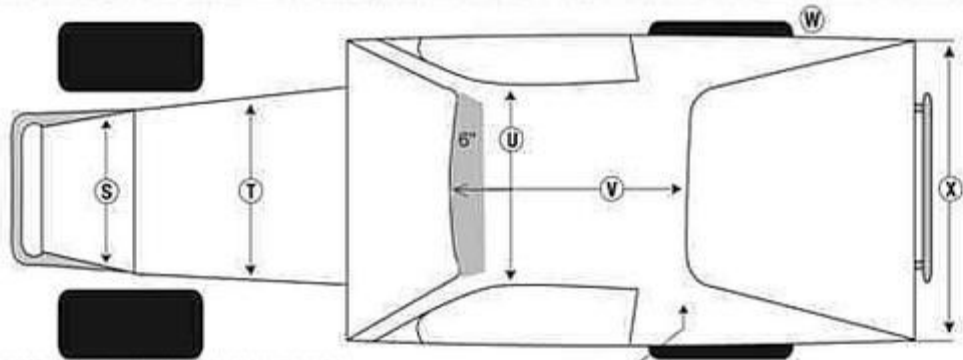

SAIL PANELS: Must not be wider than the body and must attach to the quarters in a single stock appearing plane that angles inward to the roof. No fins or lips on sail panels, body, or nose.

