

# MOUSE POINTER NAVIGATION USING SST MICROCONTROLLER

Shravan S Jois<sup>1</sup>, Sandeep Hegde<sup>1</sup>, Sugam Raju Revankar<sup>1</sup>, Sudhanva M S<sup>1</sup>, Smt.B.M.Nandini<sup>2</sup>

<sup>1</sup>Final year B.E under graduates, The National Institute of Engineering Mysore

<sup>2</sup>Department of ISE, The National Institute of Engineering Mysore  
(E-mail: shravansjois7@gmail.com)

**Abstract**—The Human-computer interaction is the study of designing the computer technology for the enhancement of communication of humans with computers.. In this paper, we have proposed designing of an economical head operated computer mouse pointer. The paper concentrates on the invention of a head-operated computer mouse pointer for paralyzed users. It uses accelerometer which is placed in the head device to estimate the position of head. Accelerometer detects the head orientation to drive displacement of the mouse pointer. The blinking of the eye activates the eye blink sensor which in turn makes the mouse pointer clicked. The keyboard functionality is achieved by the virtual keyboard where the user hovers through the keys and clicks it by blinking the eye. Since this system does not use any gesture input, it will be useful for paralyzed users.

**Keywords**—Microcontroller, Accelerometer/sensor, Eye blink sensor, Zigbee transceiver.

## I. INTRODUCTION

Use of computers has become a basic necessity in our daily lives. There are wide varieties of users including physically disabled and paralyzed persons. To simplify Human Computer interaction for these type of users a sophisticated user interface is needed. Most of the paralyzed users find it difficult to use the conventional mouse as they cannot move their hands. So there is a need for a system where use of hand is not needed and it uses head motion instead.

## II. EXISTING SYSTEM

Existing system uses gesture recognition [3] and image-based approaches which requires sophisticated image processing platform. Image based approaches require the object to be in front of camera which restricts their mobility. Devices such as a Wiimote, joystick, trackball and touch tablet need gesture . Gesture recognition systems are difficult for paralyzed users. Some of the devices measuring head movement are not efficient. The existing systems are based on ARM7TDMI [1] microcontroller which are expensive and less accurate. The compatibility of the current systems are limited only to Windows XP. The existing systems include wired modules for communication which are tedious.

## III. PROPOSED SYSTEM

To resolve the limitations such as inaccuracy of the gesture recognition, cost effectiveness and incompatibility ,is the aim of the proposed system.

The expensive ARM7TDMI [1] microcontroller has been replaced by SST microcontroller [6] which is comparatively less expensive and more accurate. Wired communication is replaced by wireless ZigBee transceiver[5] which has higher range and better connectivity. The compatibility has been extended to Windows 7. Since gesture recognition devices are not the most useful thing for the paralyzed users, proposed system uses head motion and eye blink sensor.

## IV. HARDWARE REQUIREMENTS

### A. 8051 SST Microcontroller

One of the variant of 80C51 microcontroller is P89V51RD2[6] which has 1kB RAM and 64 kB flash. The memory of flash can be wiped out and written again as many times as needed. The capability to reprogram multiple times and its inexpensiveness is the reason for its use wide variety of applications. The combination of intelligent hardware and software makes this product ideal. The protocol sent through the serial port from the computer is understood by the boot loader inside the microcontroller. The hardware and the chip inserted is identified by the "Flash magic" which is a software on the computer side. The program in the format of Intel format HEX file is sent to the target microcontroller and also can be read back. The reading back of the programmed chip is prevented by locking of the devices. It can still be wiped and used for new loading the programs even after the chip is locked.



FIGURE 1: SST microcontroller.

### B. ADXL335 Accelerometer

The ADXL335 [2][4] from the analog devices is the basis for first generation three-axis acceleration sensor board. Its wide areas of applications are movement ,slope and shock detection. The acceleration values are generated for the X-axis, Y-axis and Z-axis. The variation of voltage on few pins varies the sensitivity of the output. An analog to digital converter is needed to read the acceleration values since the output of MMA7260Q is analog.



FIGURE 2: ADXL335 accelerometer

### C. Eye blink sensor

The eye blink sensor [2] uses the phototransistor and differentiator circuit to monitor the changes in the light reflected from the eye and eyelid area by illuminating the IR rays. Emitter-detector positioning and aiming with respect to the eye, determines the exact functionality of the eye blink sensor.



FIGURE 3: Wearable with eye blink sensor

### D. Zigbee transceiver

For a flawless performance in wireless transmission with inexpensiveness and small form factor solution, in the performance of OEMs, the first choice would be the XBEE family of ZigBee/802.15.4 RF modules[5]. In the license-free 2.4 GHz ISM band Xbee modules are used throughout the globe in the field of wireless communication and are considered to be reliable.

XBee module has regular version and long-range PRO version. The pin for pin compatibility exists in all Zigbee modules but in few modules input-output features are different, which gives a basic foundation for OEMs with many applications.

Xbee modules are famous for their simplicity in the usage. They are ready to be operated out of the box. There are simple AT commands and APIs for the advanced custom configurations.



FIGURE 4: Zigbee transceiver

## V. ARCHITECTURE

The input devices are eye blink sensor and accelerometer. When the head is tilted the analog signal will be generated from the accelerometer. This analog signal is sent to the ADC0809 IC [6] which converts analog signal into digital signal. When the eyelid is closed for a fixed amount of time the infrared light generates a signal is sent from the eye blink sensor to the 8051 microcontroller [6].

8051 microcontroller which works as a small CPU used to process the incoming signal sent from the input devices. The input signals are in the digital form and they should be in hexadecimal form before sending it to the computer. An Embedded program which is burned in the 8051 microcontroller converts digital signals to the hexadecimal values. The hexadecimal values are then sent to the zigbee transmitter. Zigbee is a wireless communication medium between computer and microcontroller which uses radio frequencies for the transmission.

Zigbee transmitter is attached to the microcontroller which transmits the hexadecimal to the zigbee receiver which is connected to the computer. Hexadecimal values received from the zigbee receiver determine the motion and operation of the mouse pointer. The stored Java program in the computer uses the hexadecimal values as the input in order to implement the mouse pointer operations. The detection of the signal and the mouse pointer operations in the computer is continuous unless or until the device is disconnected from the system.

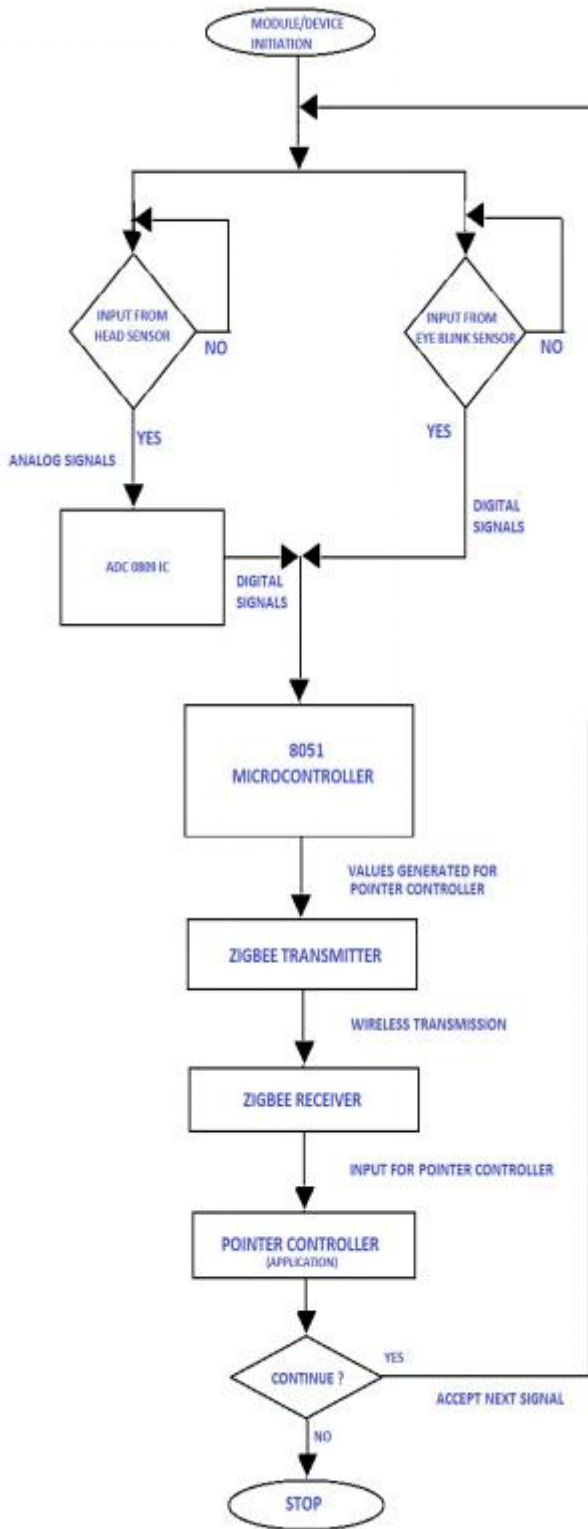

FIGURE 5: Data flow diagram for the proposed system

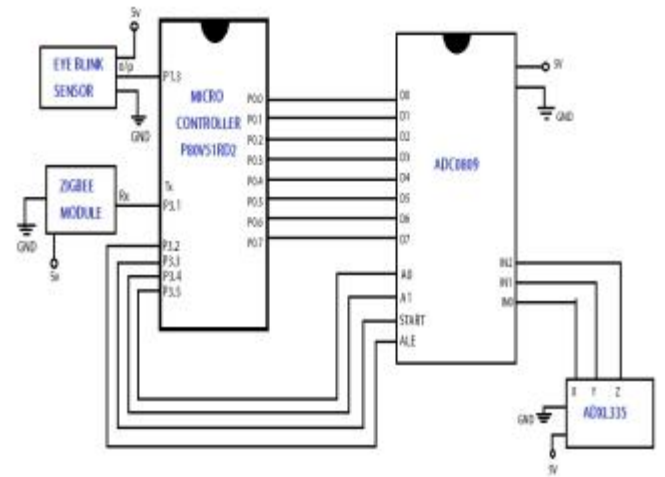

FIGURE 6: Architecture of the proposed system

VI. CONCLUSION

The implementation of the proposed system will help wide range of users especially physically challenged to be able to access computer. This wireless wearable device is accurate, efficient and cost effective. In addition to the control of general purpose PC the user can also control many embedded devices such as robotic arm, electronic wheel chair which helps the user in a variety of tasks.

REFERENCES

- [1] N. Pranathi, Syed Musthak Ahmed “Mouse navigation system with eye blink sensor for paralyzed persons”, IEEE Transactions on dependable and secure computing, Vol 12, No. 3, MAY/JUNE 2018
- [2] Meten Ayberk Fikirli, Cengiz Polat Uzunoglu, Iskender Alkin Solmaz, Mukden Ugur “Dedection of eye blink movements with sensors”
- [3] Shengli Zhou, Quing Shan, Fei Fie, Wen J Li, “Gesture recognition for interactive controllers using MEMS motion sensors”, proceedings of the 2009, 4th IEEE international conference.
- [4] A. Heydari Gorji, S. M. Safavi, Ch.T.Lee, P.H. Chou “Head Mouse- Simple cursor controller based on optical measurement of head tilt”
- [5] Shahin Farhani “Zigbee wireless networks and transceivers”
- [6] Chris Braithwaite , Fred Cowan, Hassan Parchizadeh “8051 Microcontroller an application based introduction”



Shravan S Jois  
Final year BE The National Institute of Engineering Mysuru.

Currently pursuing final year bachelor's degree in Information science and engineering in The National Institute of Engineering Mysuru. He has done projects in the area of machine learning, data mining and human computer interaction



Sandeep Hegde  
Final year BE The National Institute of Engineering Mysuru.

Currently pursuing final year bachelor's degree in Information science and engineering in The National Institute of Engineering Mysuru. He has done projects in the area of Web development, database management and human computer interaction



Sugam Raju Revankar  
Final year BE The National Institute of Engineering Mysuru.

Currently pursuing final year bachelor's degree in Information science and engineering in The National Institute of Engineering Mysuru. He has done projects in the area of web development, database management and human computer interaction



Sudhanva M S  
Final year BE The National Institute of Engineering Mysuru.

Currently pursuing final year bachelor's degree in Information science and engineering in The National Institute of Engineering Mysuru. He has done projects in the area of web development, database management and human computer interaction