



www.sealsit.com & www.sealsitoffroad.com

ECONOMY AXLE SEAL EAS15 / EAS25 / EAS35



PART # EAS15	HOUSING I.D.	AXLE SEAL I.D.	FITS AXLE O.D.	PASS THRU MAX
EAS15100 FITS	2.500 / 2.750	1.000	1.300 – 1 5/16" – 1 7/16" – 1 3/8" – 1.400	1.850
EAS15125 FITS	2.500 / 2.750	1.250	1.500 / 1 1/2" – 1.600	1.850
EAS15132 FITS	2.500 / 2.750	1.320	1 5/8" – 1.750 / 1 3/4"	1.850
PART # EAS25	HOUSING I.D.	AXLE SEAL I.D.	FITS AXLE O.D.	PASS THRU MAX
EAS25875 FITS	2.125 / 2.250	.875	1.000/1" – 1 1/16" – 1 1/8" – 1 3/16" – 1.250/1 1/4"	1.850
EAS25100 FITS	2.125 / 2.250	1.000	1.300 – 1 5/16" – 1 7/16" – 1 3/8" – 1.400	1.850
EAS25125 FITS	2.125 / 2.250	1.250	1.500/1 1/2" – 1.600	1.850
EAS25132 FITS	2.125 / 2.250	1.320	1 5/8" – 1.750/1 3/4"	1.850
PART # EAS35	HOUSING I.D.	AXLE SEAL I.D.	FITS AXLE O.D.	PASS THRU MAX
EAS35875 FITS	1.900 / 2.000	.875	1.000/1" – 1 1/16" – 1 1/8" – 1 3/16" – 1.250/1 1/4"	1.850
EAS35100 FITS	1.900 / 2.000	1.000	1.300 – 1 5/16" – 1 7/16" – 1 3/8" – 1.400	1.850
EAS35125 FITS	1.900 / 2.000	1.250	1.500/1 1/2" – 1.600	1.850

7087 RTV SILICONE - ORANGE

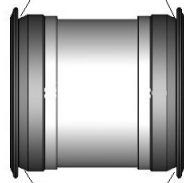

PLACE O-RING IN THESE LOCATIONS

2.000 IN HOUSING

-ONLY- AS568A-224 STD O-RING

BEFORE ASSEMBLY...

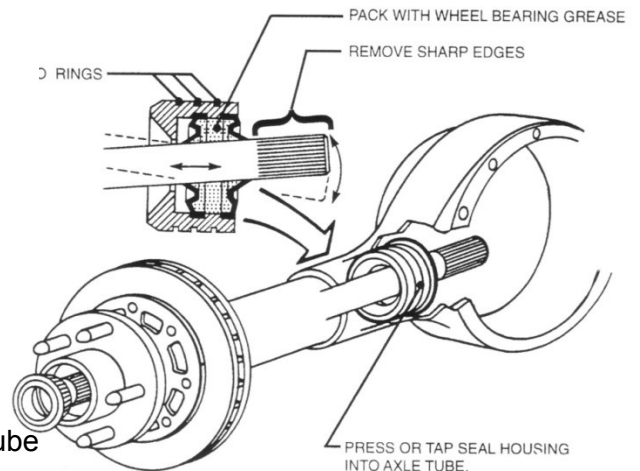

- Seal can be used at either end or both ends of the tube
- Use seal to retain gear oil in the ring and pinion
- Seal used by circle track, drag, and street customers
- Before installing seal, lightly pack a "low melt" temperature grease inside between the two seals, leaving enough room for the axle to pass through. A coating of about 1/8"–3/16" is sufficient.
- Applying a bead of orange high temperature silicone around the rubber flange of the seal will help lubricate for installation and to retain the seals location
- DO NOT HIT OR DRIVE SEAL INTO PLACE. THIS COULD RESULT IN CUTTING THE SEAL ON THE HOUSING. IF NEEDED, CALL TECH FOR ASSISTANCE ON INSTALLATION: 860-979-0045