

**Turbo air**  
AIR CONDITIONER MANUFACTURER

4184 E. Conant St.  
Long Beach, CA 90808  
Tel. 888-900-1002  
Fax. 310-900-1088  
[www.turboairinc.net](http://www.turboairinc.net)

Project :

Model # :

Item # :

Qty :

Approval :

## Top Mount Package Units (SMART 7)

**Model : STX100MR404A2**

**SMART 7**



### ≡ FEATURES / BENEFITS ≡

**SM 1: Blue Anti-corrosion-fin and Coated Copper Tube** protects aluminum and copper pipes from toxic gases generated from foods, retards refrigerant leakage, and prolongs the cooling capacity.

**SM 2: Expansion Valve** allows safe storage of foods with a feature that self-adjusts the circulation of refrigerant as the internal temperature changes, thus recovering the required temperature fast.

**SM 3: Compressor Protected Solenoid Valve** decreases the inflow of refrigerant into the compressor when it is restarted after a stop. This extends compressor life and reduces compressor failure.

**SM 4: 18% Bigger Condenser than the Standard :** The condenser's efficiency affects most of the refrigerator's performance. Particularly, when used in a small compartment under high ambient temperatures or a dusty area, the package unit's condenser needs to be bigger than standard ones in order to get the best performance. In consideration of the environments that our products may be subject to, condensers utilized in our products are 18% larger than competitors'.

**SM 5: Energy Efficient EC Motor :** Through the use of a highly efficient EC motors, our products reduce energy consumption and lower electricity costs, thus protecting the environment. Our products are designed with easy to replace motor and fan blades.

**SM 6: Leak Free Patented Hot Gas Condensate System :** The hot gas condensate system is an ideal system because of its fast evaporation of condensed water and its enhancing refrigeration efficiency. In spite of these advantages, many companies have stopped or stop the application of such a system because of its high risk of discarding the refrigerators due to the rapid corrosion of hot gas lines causing refrigerant leakage and water inflow into the cooling pipes. Such problems as this are completely resolved in our products, thanks to a patented technology that prevents pipes from corrosion.

**SM 7: Highly Efficient Air Circulation Enclosure** is designed to release hot air to the outside faster than competitors' and to enhance the cooling efficiency. At the same time, it retards elevation of compressor temperature and keeps refrigerant pressure from increasing, thus saving energy as a result.

# Top Mount Package Units (SMART 7)

## Model : STX100MR404A2

### MODEL NOMENCLATURE

S	T	I	050	M	R404A	2
Model		Location		Capacity	Temp.	Refrigerant
Turbo air		I = Indoor		BTUH	M = Medium	R404A
Top Mount		O = Outdoor		x 100	Temp.	1 = 115V
Package Unit				L = Low	Temp.	2 = 208-230V
						1PH 60Hz
						3 = 208-230V
						3PH 60Hz

### Performance Data - Medium Temperature Models, Air Defrost

Model	Capacity BTU/HR ( Ambient Temp )									
	80°F		90°F		95°F		100°F		110°F	
	Room Temperature °F.									
	35°F	38°F	35°F	38°F	35°F	38°F	35°F	38°F	35°F	38°F
STX100MR404A2	14028	15064	11868	12784	11652	12556	10799	11651	9537	10305

### Unit Specifications - Medium Temperature Models

Model	Power Supply			Unit		Evaporator	Plug	Matching	Dim.	Net Weight	
Numbet	Voltage	PH	Hz	MCA	MOPD	Amps	CFM	Supplied	Receptacle	Fig.	STI / STX
											Lbs (kg)
STX100MR404A2	208-230	1	60	14.0	20	11.6	890	No	-	C	311 (141) / 319 (145)

Design and specifications subject to change without notice

■ **WARRANTY : 2 Year Compressor and Parts Warranty & 1 Year Labor Warranty**

## PLAN VIEW

(unit : inch)

Figure C. INDOOR UNIT – Large Cabinet (Opening Size : 25 inch x 38.5 inch)

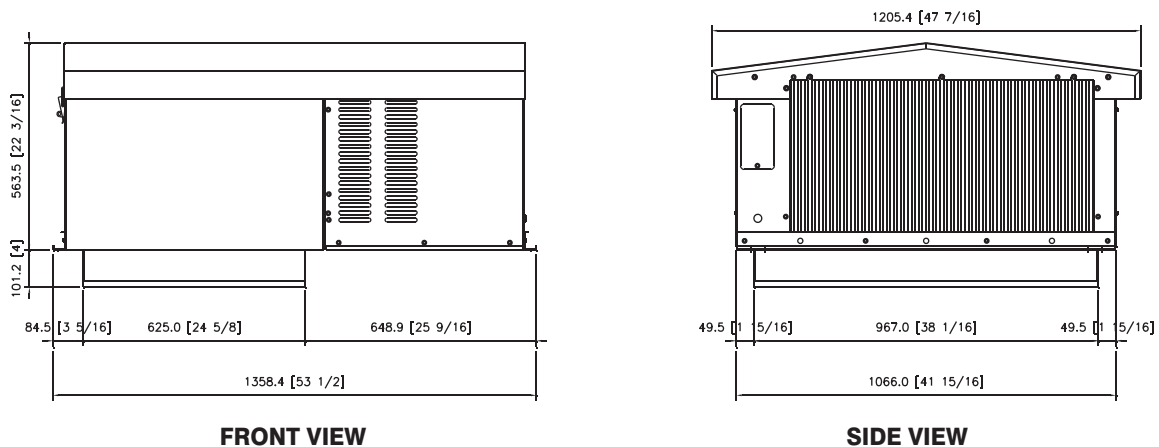

■ Toll Free : 888-900-1002

TURBO AIR REFRIGERATOR MANUFACTURER

GERMAN KNIFE

RADIANCE

GREEN WORLD

TURBO AIR AIR CONDITIONER MANUFACTURER