

# **FP14KCX-ALK**

## **FP14KC-X**

### **Airline Kit w/ FRL**

**(FRL - Filter, Regulator & Lubricator)**

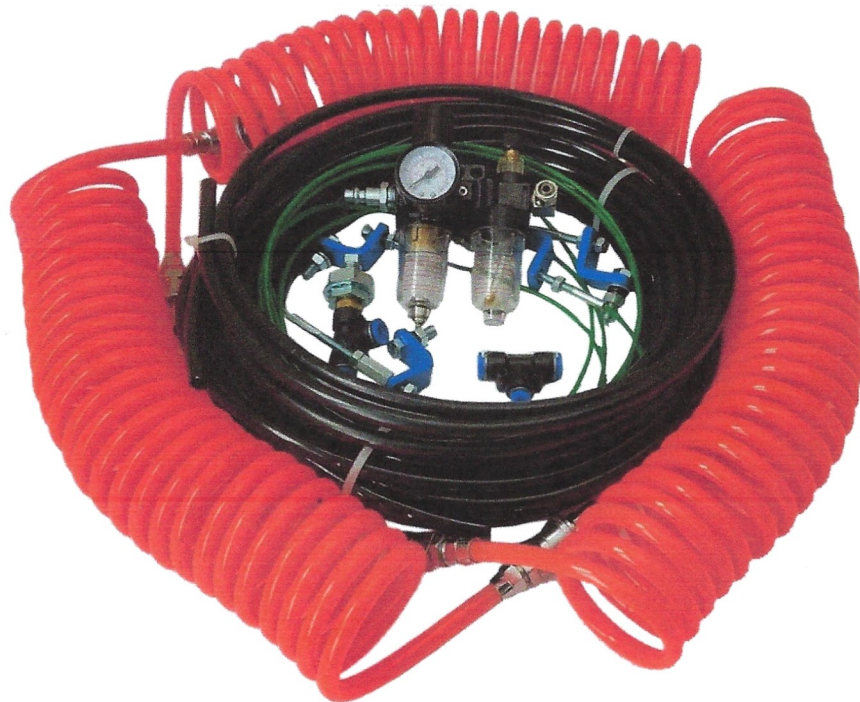

## **Installation Instructions**

### **IMPORTANT!!**

**READ MANUAL THOROUGHLY BEFORE ASSEMBLING, INSTALLING, OPERATING, OR MAINTAINING AIRLINE KIT. WHEN DONE WITH INSTALLATION BE SURE TO RETURN DOCUMENTS TO PACKAGE AND GIVE ALL MATERIALS TO LIFT OWNER / OPERATOR.**

# FP14KCX-ALK

## Air-Line Kit w/ FRL (Filter, Regulator & Lubricator)

### Product Description:

The iDEAL Air-Line Kit (FP14KCX-ALK) is designed to be applied to the four post, closed front flat deck iDEAL FP14KC-X & FP14KAC-X lift models. The Air-Line Kit provides the iDEAL FP14KCX lift models with an internal airline that provides directed compressed air to for two rolling bridge air jacks, while including an extra 'outlet' access point for air driven tools. The Air-Line Kit also includes a FRL (Filter, Regulator & Lubricator) providing additional protection & adjustments for pneumatic lift components, as well as for rolling bridge air jacks. The iDEAL Air-Line Kit is an optional accessory for the FP14KC-X Service Lift and included as standard for the FP14KAC-X Alignment Lift.

### Main Kit Components: (See Exploded View & Part List for Details)

- FRL (Filter, Regulator & Lubricator)
- Coiled Air Tubing Assy.
- Wire Guides & Brackets
- Air Fitting Connectors
- 10mm Air Tubing
- RAJ Front & Rear 'Redirect' Tubing & Fitting Components
- All Mounting Hardware

### Required Tools:

- Sockets or Open Wrench Set
- Air Tubing Cutter, Razor Blade, or Sharp Knife
- Medium Flat & Philip Screwdrivers
- Large Pliers or Channel Lock Pliers
- Safety Glasses
- Gloves

### Installation Instructions:

**CAUTION:** Disconnect compressed shop air supply from lift, prior to Air-Line Kit installation.

#### Step 1: Control Bracket & Air Valve

- 1) Raise lift to a comfortable working height to gain access to the underside of Main Side Runway, then lower lift onto Safety Latches.
- 2) If already connected, remove Air Inlet Fitting Assembly from Control Bracket, and set aside for reuse. Air Tubing connected to Inlet Fitting Assembly to stay connected to Air Valve inlet port, Fig. 1.

**NOTE:** Use 'Quick Disconnect' Air Inlet Fitting used from FP14KC-X Hardware for FLR 'Inlet' Port, Fig. 2.

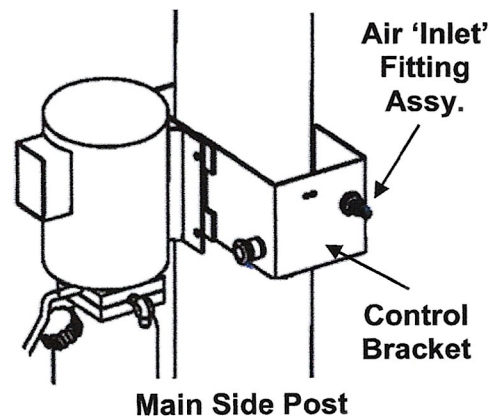
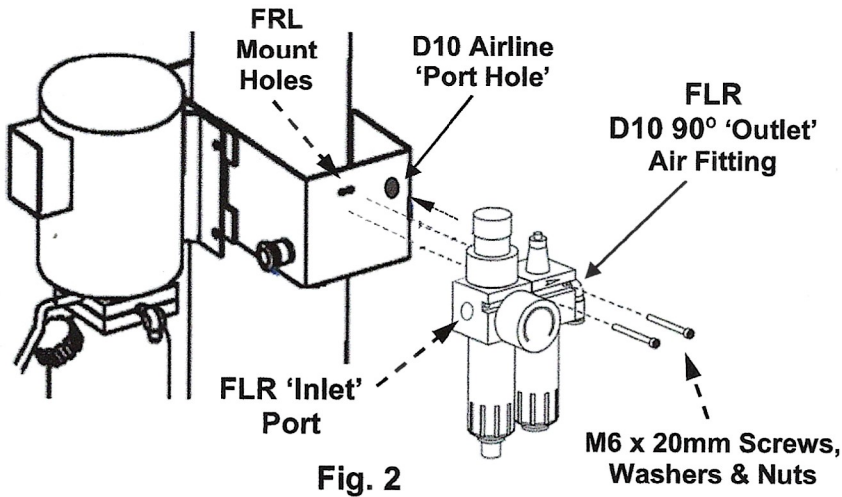

Fig. 1



- 3) Using the M6 x 20mm Screws, Washers & Nuts, mount FRL (Filter, Regulator & Lubricator) to the two holes located on the side of Control Bracket, **Fig. 2**. Ensure FLR's 90° 'Outlet' Air Fitting is aligned with 'port hole' in Control Bracket to route D10 Airline in following steps.
- 4) Install Quick-Disconnect 'Inlet' Fitting to the FLR 'Inlet' port, **Figs. 2 & 3**.



**Fig. 2**

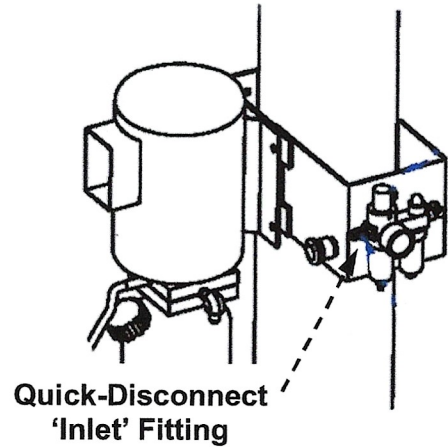

**Fig. 3**

**NOTE:** To assemble airline tubing into push fittings, use firm pressure to push tubing into fitting until it bottoms out. Ensure tubing is cut square with no burrs.

- 5) Using D10 Airline & Air Fitting T-Connector Reducer (M10-M6), cut a 4" to 5" length and connect to outlet port on FRL, making sure to route through the hole in the Control Bracket. Connect the other end, routed through hole in Bracket to one of the (M10) T-Fitting push ends, **Figs. 4 & 5**.
- 6) Connect the previously disconnect D6 Airline end from the Air 'Inlet' Fitting to the (M6) T-Fitting end that goes to the Air 'Inlet' Valve Port 'A', **Figs. 4 & 5**.

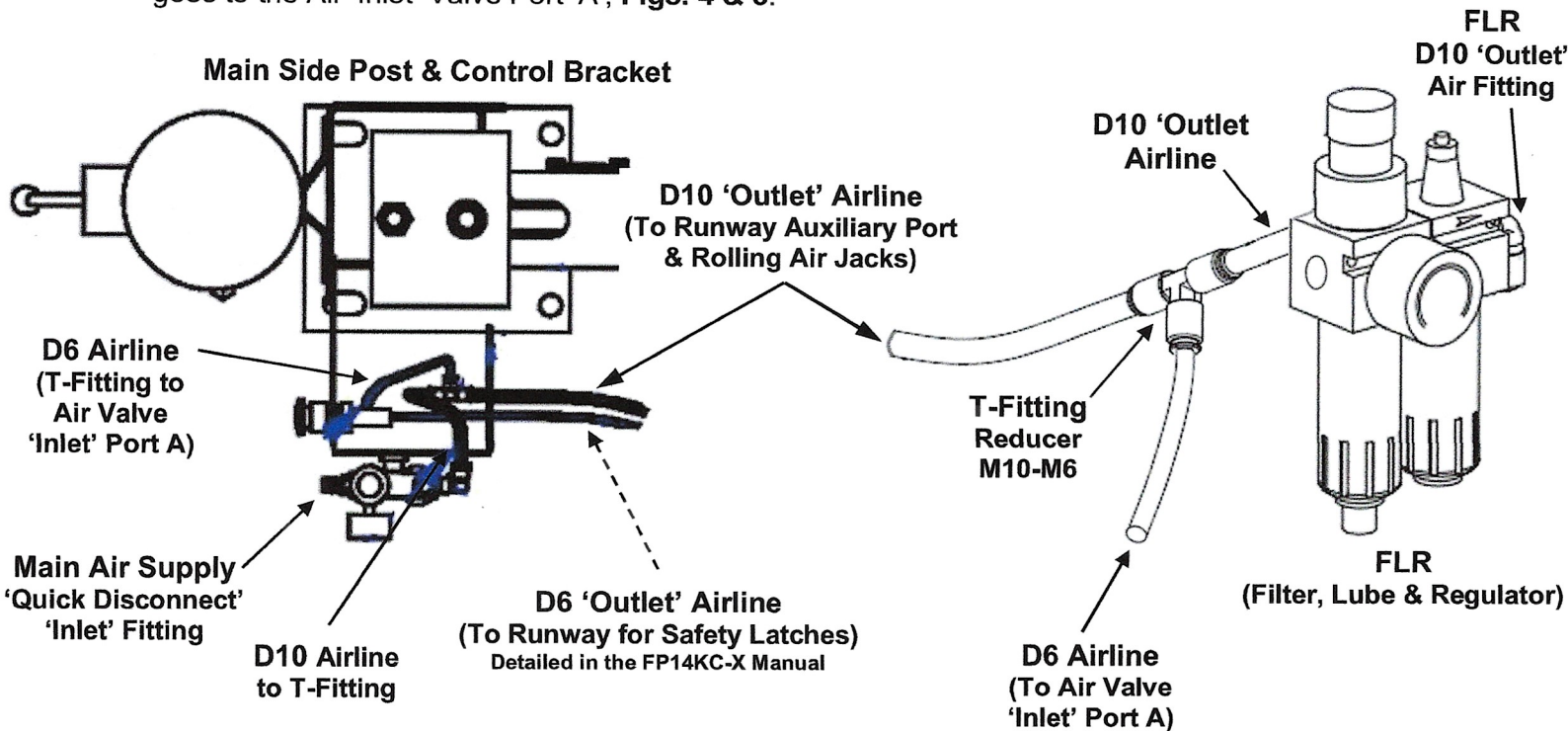

**Fig. 4**

**Fig. 5**

- 7) Using D10 x 71" Airline, connect to remaining (M10) T-Fitting end in Fig. 5, then carefully route through the Corrugated Tubing to extend through runway hole and over & across to Auxiliary Air Outlet Port located on inside, front section of the runway, Fig. 6.

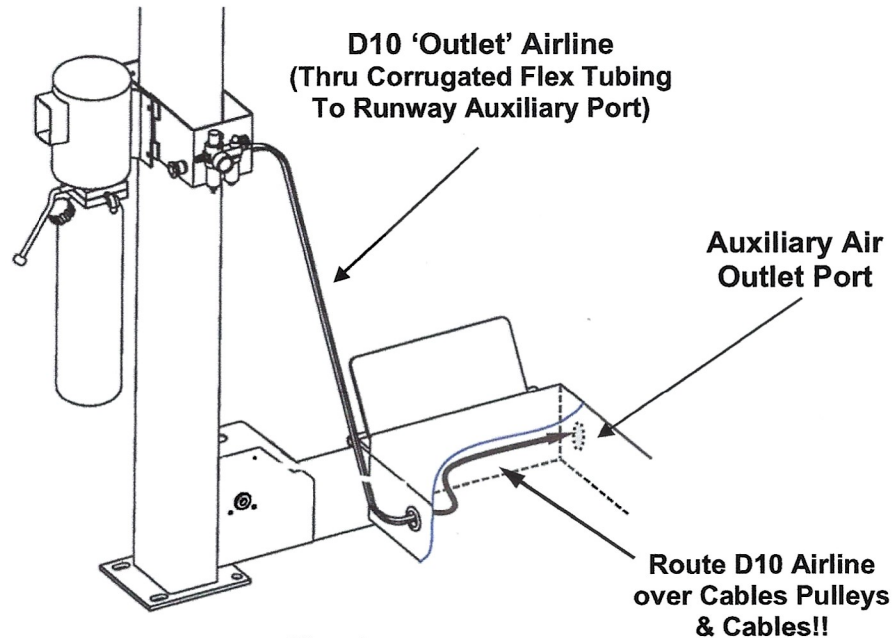

Fig. 6

**CAUTION:** Ensure D10 Airline is routed above the Cable Pulleys on underside on Runway!!

## Step 2: Main Side Runway

- 1) For Auxiliary Air Outlet Port. mount the (M10) Run T-Fitting Connector & Plug Assembly to runway port, ensuring the 'T' section of Run T-Fitting is pointed towards the rear of runway, with the Hex Female Bushing & Plug end inserted through port hole in Runway. Secure T-Fitting with 45mm Jam Nut, Fig 7.
- 2) Using the previously routed D10 Airline, cut airline to length (if needed) to connect to the T-Fitting's push end, directly across, ensuring the D10 airline is routed above & clear of Cable Pulleys, Figs. 7 & 8.

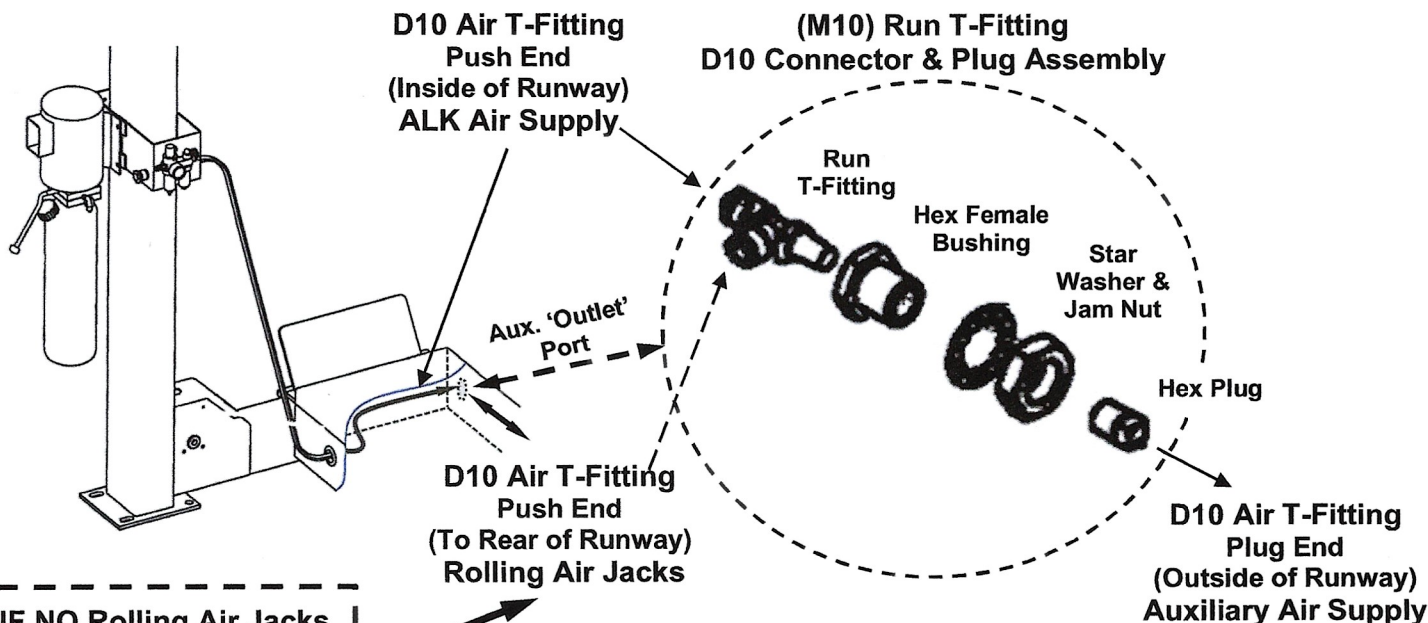

Fig. 7

**NOTE:** IF NO Rolling Air Jacks  
Must Plug T-Fitting Push End!  
(Plug Not Supplied in Kit)

Air Fitting T-Connector to the middle of section of Main Side Runway, ensuring



the 'T' end is positioned to the outside of runway towards jack rails. Secure Bulkhead Air Fitting T-Connector to runway with 45mm Female Busing, Washers & Jam Nut. Next, mount (M10) Air Fitting 90° Connector to Hex Female Bushing, positioned to the inside of the runway, **Fig 8**.

- 4) Using D10 x 110" Airline, connect to Auxiliary Port's T-Fitting's push end, on the inside of front of runway, **Fig. 7**; then route D10 airline to connect to the (M10) Air Fitting 90° Connector, **Fig. 8**.
- 5) Connect both Coiled Air Tubing's 'threaded ends' to each side of the Bulkhead T-Connector. Note: The Female 'Quick Connector ends will connect to Rolling Jacks, **Fig. 8**.

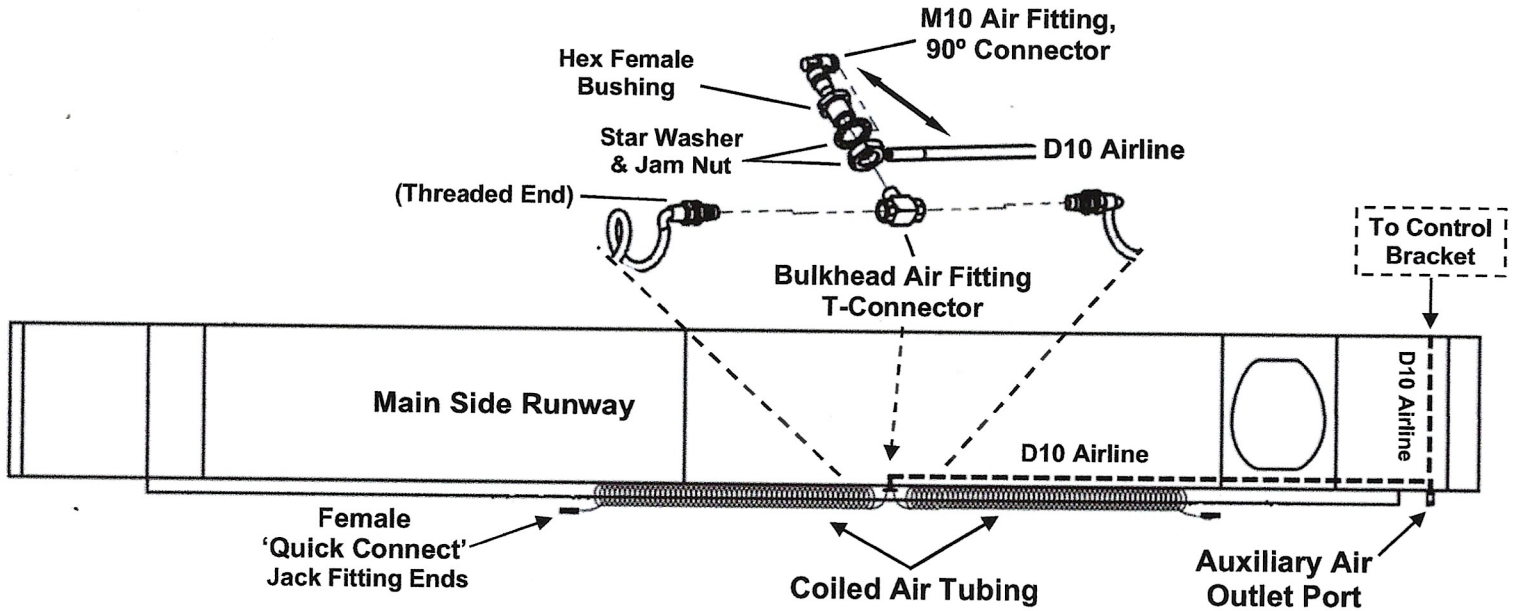

**Fig. 8**

- 6) Attach 4ea Angle Brackets to the mount holes on the inside of Main Side Runway using M8 x 30mm Hex Bolts, M8 Flat & Lock Washers, and Hex Nuts, as shown in **Fig 9**.
- 7) After attaching Angle Brackets to runway, route the Guide Wires (Front, Rear & Center) through Coiled Air Tubing, then attach ends to Angle Brackets using 8ea 1/4" Hex Nuts & 2ea Hex Coupler Nuts, **Fig 9**.

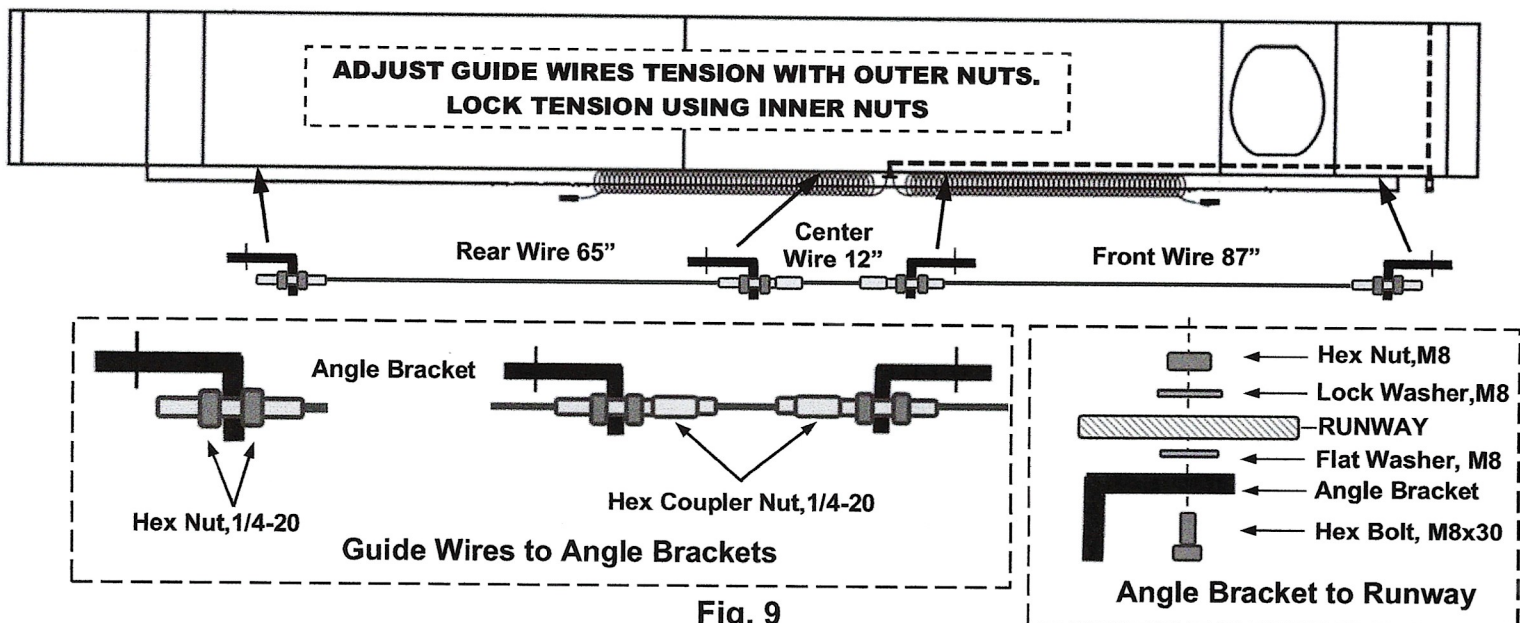
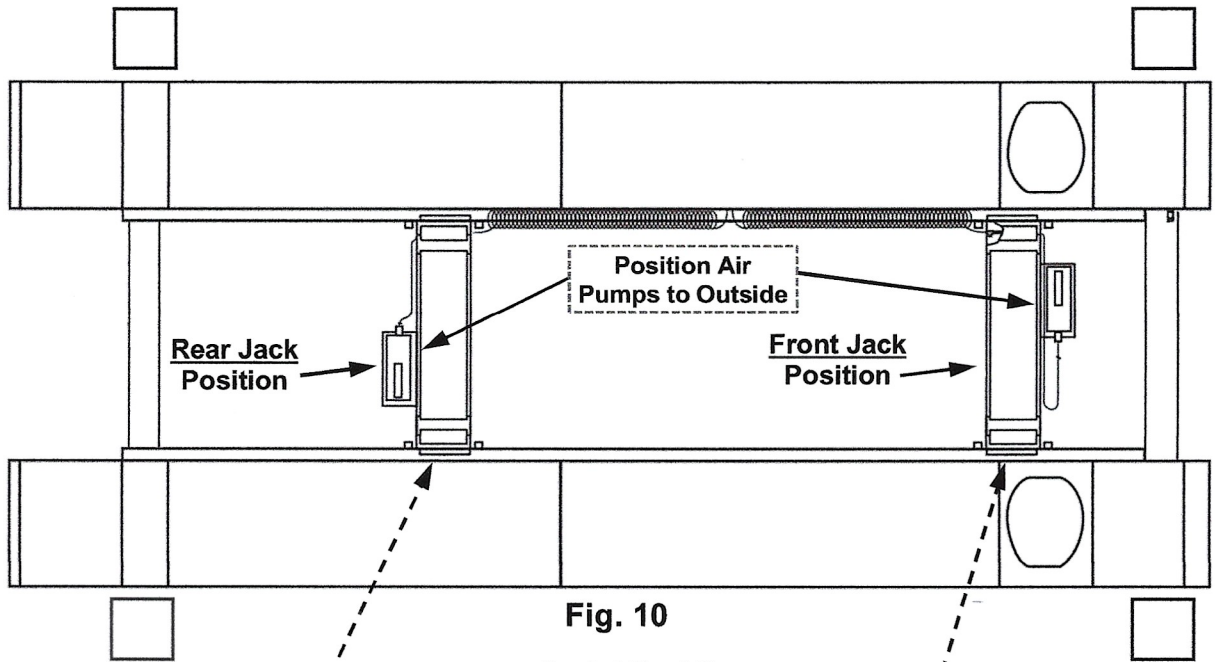

**Fig. 9**

### Step 3: Rolling Bridge Jacks (RAJ-7K-H)

**NOTE:** RAJ-7K-H Rolling Bridge Jacks should already be installed on Runways.

- 1) Ensure Rolling Bridge Jacks are already positioned & installed on runways, as shown below in **Fig. 10**.
- 2) For both Front & Rear Rolling Jacks, mount Connector Block to the threaded holes already applied to top & side of each Jack's Frame using 2ea M6 x 12mm Socket Head Screws & D6 Lock Washers, **Fig. 11**.
- 3) Install (M8) Air Fitting, Straight Connectors to the 'inside' of each Connector Block, while also installing Straight Connectors to the Hex Coupler Fittings (already applied) for each Air / Hydraulic Pump, **Fig. 11**.
- 4) Using D8 Airline, cut to length & route for Front & Rear Jacks, as shown in **Figs. 11A & 11B**. After Airlines are connected to both Jacks, connect to Coiled Tubing ends to Jacks, using Quick Disconnect Fittings.



**Fig. 10**

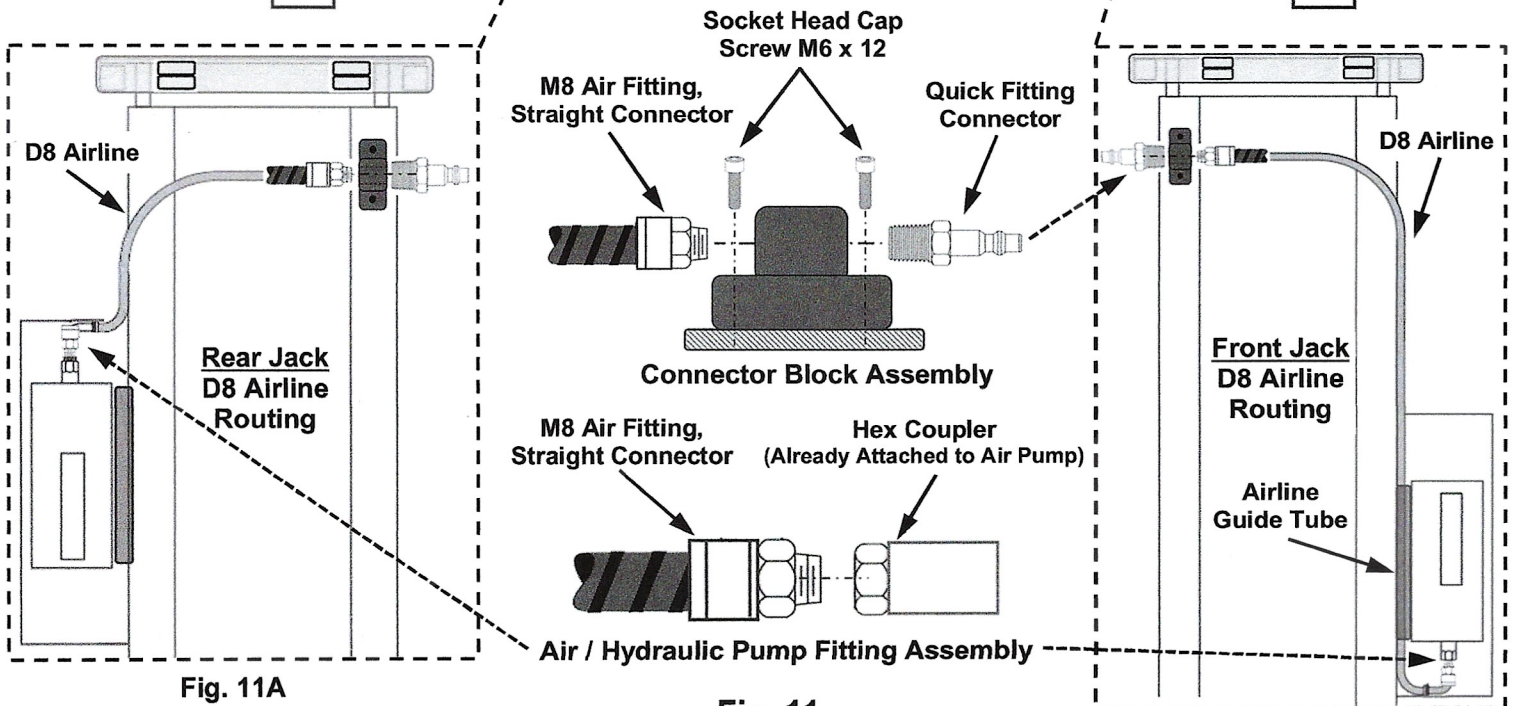

**Fig. 11A**

**Fig. 11**

**Fig. 11B**





## Parts List

ITEM	Tux P/N	M-REF P/N	DESCRIPTION	QTY
1	FP14KCX-ALK-001	Ø10 x 1.8 meter	Air Tubing, D10 x 71"	1
2	FP14KCX-ALK-002	Ø10 x 12'	Coiled Air Tubing Assy. D10 x 12'L	2
3.1	FP14KCX-ALK-003.1	TT-8861-600-01-3.1	Rear Guide Wire - 65.7" (1670mm)	1
3.2	FP14KCX-ALK-003.2	TT-8861-600-01-3.2	Front Guide Wire - 87" (2210mm)	1
3.3	FP14KCX-ALK-003.3	TT-8861-600-01-3.3	Center Guide Wire - 12.2" (309mm)	1
4	FP14KCX-ALK-004	Ø10 x L=2.8meter	Air Tubing, D10 x 110"	1
6	FP14KCX-ALK-006	SPL10-02	Air Fitting, 90° Connector, M10	1
7	FP14KCX-ALK-007	TT-8861-600-02	Angle Bracket, Guide Wire	4
8	FP14KCX-ALK-008	TT-8861-600-03	Hex Female Bushing, 45mm	2
9	FP14KCX-ALK-009	TT-8861-600-04	Jam Nut, 45mm	1
10	FP14KCX-ALK-010	GB/T861.1-1987 D20	Star Lock Washer, D20	2
11	FP14KCX-ALK-011	GB5783-2000 M8x30	Bolt, M8 x 30mm	4
12	FP14KCX-ALK-012	GB95-1985 D8	Flat Washer, D8	4
13	FP14KCX-ALK-013	GB6170-2000 M8	Hex Nut, M8	4
14	FP14KCX-ALK-014	UNC1/4"-20	Hex Nut, 1/4"-20	8
15	FP14KCX-ALK-015	GB93-1987 D8	Lock Washer, D8	4
16	FP14KCX-ALK-016	TT-8861-600-05	Hex Coupler Nut, 1/4"-20	2
17	FP14KCX-ALK-017	TT-8861-600-06	Bulkhead Air Fitting T-Connector	1
18	FP14KCX-ALK-018	TT-8861-600-07	Hex Cap Plug	1
19	FP14KCX-ALK-019	SPEN10-6	Air Fitting, T-Connector, M10/M6	1
20	FP14KCX-ALK-020	SPL10-02	Air Fitting, 90° Connector, M10	1
21	FP14KCX-ALK-021	SPD10-02	Air Fitting, Run T-Connector, M10	1
22	FP14KCX-ALK-022	TT-8861-600-08A	*Air Inlet Fitting, 1/4" (Type D)	*RPL
23	FP14KCX-ALK-023	DAFC2000	(FRL) Filter, Regulator & Lubricator	1
24	FP14KCX-ALK-024	TT-8861-600-08	Air Fitting, Quick Connector (PM20)	2
25	FP14KCX-ALK-025	GB818-2000 M6x20	Screw, M6 x 20mm	2
26	FP14KCX-ALK-026	GB95-1985 D6	Flat Washer, D6	2
27	FP14KCX-ALK-027	GB93-1987 D6	Lock Washer, D6	2
28	FP14KCX-ALK-028	GB6170-2000 M6	Hex Nut, M6	2
29	FP14KCX-ALK-029	LJ07-0100-000	Air Fitting, Connector Block (RAJ-7K)	2
30	FP14KCX-ALK-030	DT01-13001-000	Air Fitting, Straight Connector, M8 (RAJ-7K)	4
31	FP14KCX-ALK-031	LJ01-11000-FJ1	Air Tubing #1, D8 (Front, RAJ-7K)	1
32	FP14KCX-ALK-032	LJ01-12000-FJ1	Air Tubing #2, D8 (Rear, RAJ-7K)	1
33	FP14KCX-ALK-033	GB70.1-2000 M6*12	Socket Head Cap Screw, M6 x 12mm	4
34	FP14KCX-ALK-034	GB93-1987 D6	Lock Washer, D6	4