

TESA Micro-Hite 3D manual Machine Version 454 or 474

- Fast and easy workpiece alignment.
- Point-to-point part probing or manual scanning.
- ZMouse for significant time savings.
- Fine adjust device.
- TESA-REFLEX MH3D software.

Main Features

- Three probe heads are available:
 - TESASTAR with adjustable trigger force
 - Indexable TESASTAR-i
 - Indexable TESASTAR-i M8 with matching coupling thread (optional)

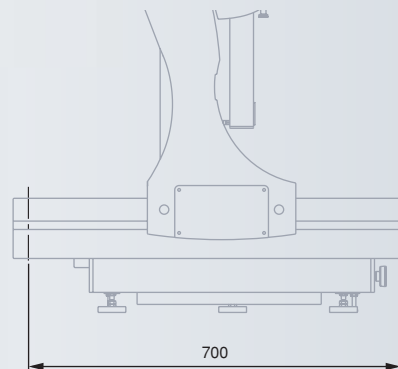
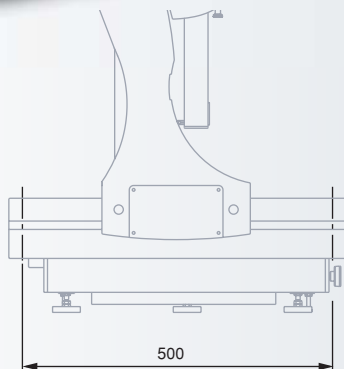

General

- ✓
- EN ISO 10360-2
- CMM with moving bridge.
- Measuring systems along with air bearing guiding in the three axes.
- Measuring volume (X/Y/Z):
Machine version 454 460 x 510 x 420 mm
Machine version 474 460 x 710 x 420 mm
- TESA-REFLEX MH3D:
0,001 mm or 0.00001 in
- Manual or motorised (RC version only)
- Light alloy machine base; measuring table in granite.
- Opto-electronic measuring systems based on incremental glass scales
- 0,039 µm (system)
- Manual version: 760 mm/sec.
RC version: 1 µm/pas, 10 or 20 mm/sec.
- TESA-REFLEX MH3D Control Panel**
- 154 x 116 mm display field with illuminated background
- 7-decade display (digits) plus sign for the measured values. Icon-based graphic User's interface .
- RS232
- $MPE_E^* = (3 + 4 L/1000) \mu m$
 $MPE_P = 3 \mu m$
* L in mm

