



Instruction Manual
PLS 9600 Series
8 Point level System



Sensaras

275 Marcus Blvd. Unit S
Hauppauge NY.11788
USA
1-631-524-5775

General.

The PLS9600 Series is a multipoint liquid level system that is designed primarily for the Semiconductor Industry to detect various purity liquid chemicals at specified levels in precursor bubblers and ampoules.

The system uses Ultrasonic Technology to sense the presence or absence of the chemical in a container. There are no moving parts in the system; it is not dependent on the dielectric constants, color, density and viscosity of the chemical to function correctly.

The Probe is constructed in 316LSS and is designed to stay with the container during use and transport for refill. The probes are Vacuum leak tested to within 5E-09 ATM-CC/Sec HE.

The option for a K-type thermocouple is available.

The Electronic Module is designed to function without calibration allowing the probe to be functional no matter the chemical, the chemical density, color or viscosity. The standard output is a 1A SPDT for each point. A fail safe is built in to notify if the sensor is connected or not.

Installation.

The probes are to be installed in the vessel as per requirements, be careful not to damage the VCR seal. Leak test the system before filling the vessel with chemical.

The electronic module has 4 mounting holes in the enclosure for installation (see dimensions). Be sure to install the enclosure on an electrically grounded surface.

The input power to the system is 24VDC +/- 10% consuming 250mA.

Remove the 2 pin terminal block from the electronic module to connect the power (see power wiring).

Make certain that the power source is off before connecting the 3 pin power connector to the electronic module.

Connect power to the electronic module.

- Power on – No sensor connected – Relays De-energized – LEDs Blink.
- Sensor connected (dry) - Relays de-energize- LED's turn RED.
- Sensor connected (wet)- Relays energize - LED's turn Green.

Dimensions.

The Probe is custom made per drawing with Customer approval.

Dimensions of sensing points (A,B,C,D,E,F,G,H and L) Taken from VCR gland.

The Electronic Module.

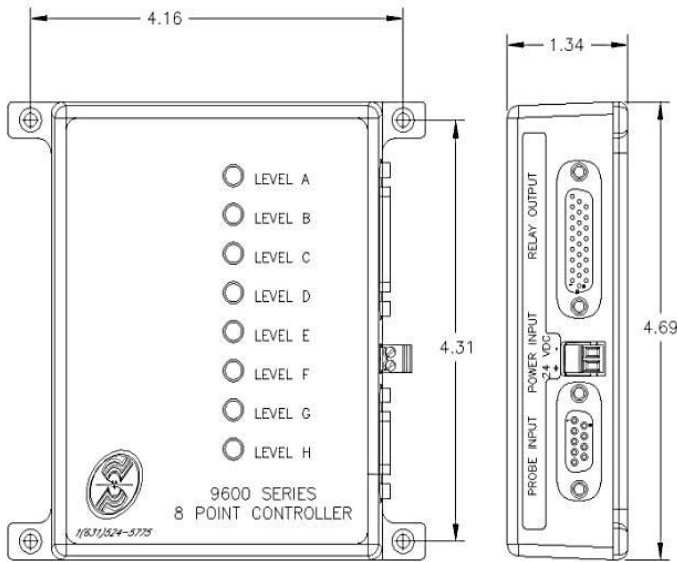

WIRING 15 PIN HD MALE
RELAY OUTPUT

PIN	FUNCTION
1	LEVEL A N.O. CONTACT
2	LEVEL B N.O. CONTACT
3	LEVEL C N.O. CONTACT
4	LEVEL D N.O. CONTACT
5	LEVEL E N.O. CONTACT
6	LEVEL F N.O. CONTACT
7	LEVEL G N.O. CONTACT
8	LEVEL H N.O. CONTACT
9	SPARE
10	LEVEL A C. CONTACT
11	LEVEL B C. CONTACT
12	LEVEL C C. CONTACT
13	LEVEL D C. CONTACT
14	LEVEL E C. CONTACT
15	LEVEL F C. CONTACT
16	LEVEL G C. CONTACT
17	LEVEL H C. CONTACT
18	SPARE
19	LEVEL A N.C. CONTACT
20	LEVEL B N.C. CONTACT
21	LEVEL C N.C. CONTACT
22	LEVEL D N.C. CONTACT
23	LEVEL E N.C. CONTACT
24	LEVEL F N.C. CONTACT
25	LEVEL G N.C. CONTACT
26	LEVEL H N.C. CONTACT

WIRING 9 PIN D FEMALE
SENSOR INPUT

PIN	FUNCTION
1	SIGNAL 'A'
2	SIGNAL 'B'
3	SIGNAL 'C'
4	SIGNAL 'D'
5	SIGNAL 'E'
6	SIGNAL 'F'
7	SIGNAL 'G'
8	SIGNAL 'H'
9	V-PROBE CONNECT/ GND

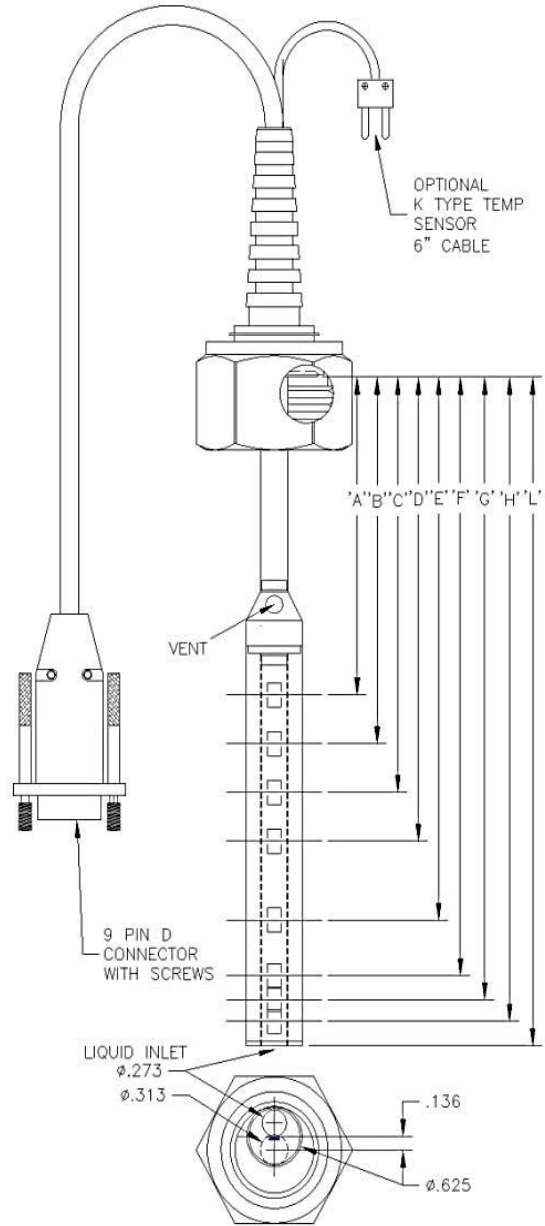

Warranty:

Sensaras LLC, products are warranted to be free from defects in material and workmanship for a period of 12 months from the date of shipment of the original Purchaser and Order. This warranty applies to the general purchaser and to components installed, serviced and operated according to the instruction manual. Sensaras will repair or replace at its option.

Claims are to be made in the warranty period. It does not apply to any component that has been damaged due to improper installation, exposed to unusual atmospheric conditions, misuse, misapplied or damage due to neglect, damage, abuse, altering or repairing.

- The Sensaras products must be maintained and installed in strict accordance with the National Electrical Code and the applicable.
- The Sensaras Product Instruction Bulletin that covers installation, operation and proper maintenance. Failure to observe this information may result in serious injury or damages.
- Please adhere to the pressure and temperature limitations shown in drawings and specifications. These limitations must not be exceeded. These pressures and temperatures take into consideration possible system surge pressures / temperatures and their frequencies.
- Selection of materials for compatibility with the media is critical to the life and operation of the Sensaras products.
- Ambient temperature changes do affect switch set points, since the gravity of a liquid can vary with temperature.
- Our sensors have been designed to resist shock and vibration. However, shock and vibration should be minimized.
- Filter liquid media containing particulate and/or debris to ensure the proper operation of our products.
- Our sensors must not be field-repaired.
- Physical damage sustained by product may render it unserviceable.

Material Returns:

Returns are accepted on stock items up to 30 days from date of order. You must contact our Returns Department for a Return Material Authorization (RMA) # Return the goods - freight prepaid - in the original container and include original packing slip.

C. O. D. returns are not accepted. Sensaras reserves the right to apply restocking charges.

Telephone: 1-631-524-5775.

PLS9608-11/14