

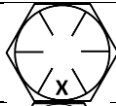





TABLE OF CONTENTS

BEAM CLAMPS	16-17	STRUT FITTINGS	11-12
BLUE BANGER HANGERS	40-44	TEK SCREWS - DOMESTIC	45-50
CARBON STEEL NUTS	2	WEDGE ANCHORS	37
CHANNEL (STRUT)	4-9		
CLEVIS HANGER	18		
CONTINUOUS THREADED ROD	3		
DROP-IN ANCHORS	38-39		
DURA-BLOK	10		
HANGER SIZING GUIDE -	28		
HEX BOLTS	1		
HOLDRITE	30-36		
INSULATION SHIELDS	27		
LIGHT DUTY CLEVIS HANGERS	22		
METACAULK	51-52		
PIPE ROLLER HANGER	22		
PRO SHIELDS	25		
QUICK SHIELDS	26		
RING HANGERS	20-21		
RISER CLAMPS	23-24		
SIKA FLEX	53-54		
SNAPPITZ	29		
STRUT CLAMPS	13-15		

HEX BOLTS

Grade Designation	Nominal Size of Product, in.	Material and Treatment	Proof Load Stress, ksi	Yield Strength ksi Minimum	Tensile Strength ksi Minimum	Surface Maximum	Core Minimum	Core Maximum	Grade I.D. Marking
A307 Gr.A ZINC	1/4 - 4	Low or medium carbon steel	---	---	60	---	B69	B100	N/A
A307 Gr.B ZINC	1/4 - 4		---	---	60 min 100 max	---	B95	B95	
SAE Gr.1	1/4 - 1-1/2		33	36	30	---	B70	B100	
SAE Gr.2	1/4 - 3/4	Low or medium carbon steel, cold worked	55	57	74	---	B80	B100	N/A
SAE Gr.5	1/4 - 1	Medium carbon steel - material is quenched and tempered	85	92	120	30N54	C25	C34	
	1-1/8 - 1-1/2		74	81	105	30N50	C19	C30	
A449 Type 1	1/4 - 1		85	92	120	---	C25	C34	
	1-1/8 - 1-1/2		74	81	105	---	C19	C30	
	1-3/4 - 3		55	58	90	---	B91	B100	
A325 Type 1	1/2 - 1		85	92	120	---	C24	C35	
	1-1/8 - 1-1/2		74	81	105	---	C19	C31	
SAE Gr.5.2	1/4 - 1	Low carbon boron steel - product is quenched and tempered	85	92	120	30N56	C26	C26	
A325 Type 3	1/2 - 1	atmospheric corrosion resistant steel; the product is quenched and tempered	85	92	120	---	C26	C36	
	1-1/8 - 1-1/2		74	81	105	---	C19		
SAE Gr.8	1/4 - 1-1/2	medium carbon alloy steel; the product is quenched and tempered	120	130	150	30N58.6	C33	C39	
A354 Gr.BD	1/4 - 2-1/2		120	130	150	---	C33	C39	
	2-3/4 - 4		105	115	140	---	C31	C38	
A490 Type 1	1/2 - 1-1/2		120	130	150 min 170 max	---	C33	C38	
SAE Gr.8.2	1/4 - 1	low carbon boron steel; the product is quenched and tempered	120	130	150	30N58.6	C33	C39	
A490 Type2	1/2 - 1		120	130	150 min 170 max	---	C33	C38	
A490 Type 3	1/2 - 1-1/2	atmospheric corrosion resistant steel; the product is quenched and tempered	120	130	150 min 170 max	---	C33	C38	

CARBON STEEL NUTS

Strength Grade of Nuts	Dimensional Style of Nut	Nominal Nut Size, in.	Non-Galvanized Nuts	Galvanized Nuts	Minimum	Maximum
A563 Gr. A	Hex	1/4 to 1-1/2	90	68	B68	C32
	Heavy Hex	1/4 to 4	100	75		
	Hex Thick	1/4 to 1-1/2				
SAE Gr. 2	Hex	1/4 to 1-1/2	90	---	---	C32
A563 Gr. B	Hex	1/4 to 1	120	90	B69	C32
		1-1/8 to 1-1/2	105	79		
	Heavy Hex & Hex Thick	1/4 to 1	133	100	B69	C32
		1-1/8 to 1-1/2	116	87		
SAE Gr. 5	Hex	1/4 to 1	120	---	---	C32
		1-1/8 to 1-1/2	105	---		
A563 Gr. C A563 Gr. C3	Heavy Hex	1/4 to 4	144	144	B78	C38
A563 Gr. D A194 Gr. 2	Hex	1/4 to 1-1/2	135	135	B84	C38
	Heavy Hex	1/4 to 4	150	150		
A563 Gr. D	Hex Thick	1/4 to 1-1/2	150	150	B84	C38
SAE Gr. 8	Hex	1/4 to 5/8	150	---	C24	C32
		3/4 to 1			C26	C34
		1-1/8 to 1-1/2			C26	C36
A563 Gr. DH A194 Gr. 2H	Hex	1/4 to 1-1/2	150	150	C24	C38
A563 Gr. DH A563 Gr. DH3 A194 Gr. 2H	Heavy Hex	1/4 to 4	175	175		
A563 Gr. DH	Hex Thick	1/4 to 1-1/2	175	175		

A307 Zinc Bolts and Nuts electrodeposited plating are covered in ASTM B633 and in Federal Specification QQ-Z-325.

Cadmium electrodeposited plating are described in ASTM A165 and QQ-P-416. ASTM B695 deals with zinc mechanical plating, and ASTM B696 with cadmium mechanical plating. Electroplated threaded metric fasteners are described in an ISO standard (ISO 4042) and a companion ASTM standard. These two documents detail recommendations on thread assembly characteristics and give guidance on needed adjustments to thread sizes prior to plating. There are no nationally recognized standards for phosphate coatings although one is being developed under the auspices of the ASTM. A comprehensive cross index of standards covering the ASTM, Federal, Military, SAE, and ISO documents for all types of organic and inorganic coatings and plating is published in Volume 02.05 of the Annual Book of ASTM Standards.

CONTINUOUS THREADED ROD



FUNCTION: Useful in applications where stud lengths cannot be predetermined.

MATERIAL: Low carbon steel

FINISH: Plain, Zinc, and Stainless Steel 304

MANUFACTURER: Vulcan Threaded Products

Rod Size	Packaging Feet per Bundle 6 ft.	Packaging Feet per Bundle 10 ft.	Packaging Feet per Bundle 12 ft.	Max. Rec. Load/lbs. 650 F	Max. Rec. Load/lbs. 750F	Wt. Per Inch/lbs.
1/4"-20	300	500	600	240	210	0.12
3/8"-16	150	200	240	610	540	0.29
1/2"-13	72	120	144	1130	1010	0.54
5/8"-11	48	80	96	1810	1610	0.83
3/4"-10	30	50	60	2710	2420	1.25
7/8"-9	24	40	48	3770	3360	1.65
1"-8	12	20	24	4960	4420	2.25

STAINLESS STEEL THREADED ROD				
Rod Size	Packaging Feet per Bundle 12 ft.	Tensile PSI	Yield 0.2% - PSI	Hardness
1/4"-20	600	111,800	80,700	92
5/16"-18	420	105,471	86,675	96
3/8"-16	300	100,400	87,700	99
1/2"-13	144	112,622	90,924	99
5/8"-11	96	113,738	92,882	98
3/4"-10	60	110,025	88,284	97
7/8"-9	48	94,200	70,100	83
1"-8	24	94,492	74,781	94

1-5/8" x 1-5/8" x 12ga. Channel

MATERIAL: Low Carbon Steel

FINISH: Plain, Painted Green, or Pre-Galvanized

STOCK LENGTH: 10' or 20' lengths

MANUFACTURER: Haydon Corporation

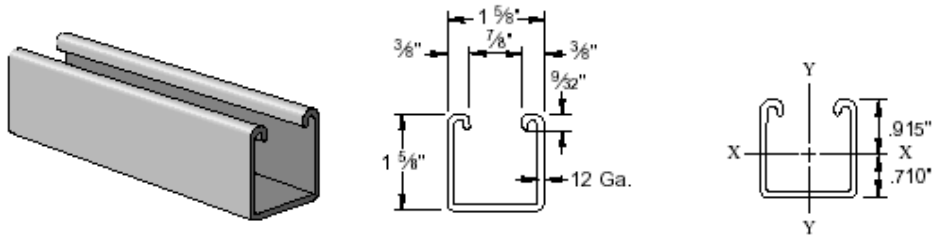

Channel	Weight	Areas of Section	X - X Axis			Y - Y Axis		
			Moment of Inertia (I)	Section of Modulus (S)	Radius of Gyration (r)	Moment of Inertia (I)	Section of Modulus (S)	Radius of Gyration (r)
			Lbs/ft.	Sq. in.	Inch ⁴	Inch ³	Inch	Inch ⁴
H-132-OS	1.89	0.552	0.188	0.208	0.584	0.236	0.290	0.654
H-132-OSA	3.78	1.104	0.947	0.583	0.926	0.473	0.582	0.655

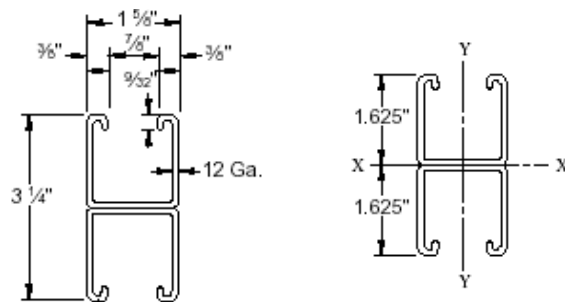
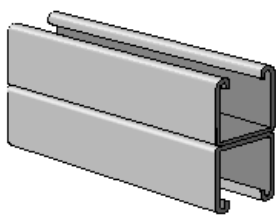

Elongated Holes

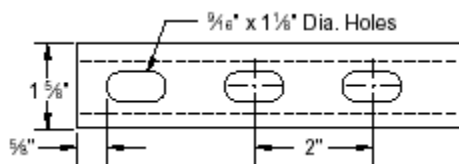
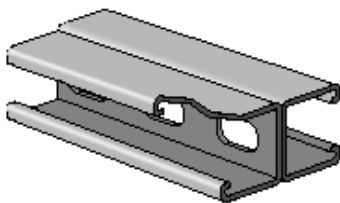

BEAM LOADING DATA

1-5/8" x 1-5/8" x 12ga. CHANNEL

Span or Unbraced Height (In)	Static Beam Load (X-X Axis)						Max. Allowable Load at Slot Face (Lbs)	Column Loading Data			
	Max Allowable Uniform Load (Lbs)	Deflection at Uniform Load (In)	Uniform Load at Deflection					Max. Column Load Applied at C.G.			
			Span/180 Deflection (Lbs)	Span/240 Deflection (Lbs)	Span/360 Deflection (Lbs)	Weight of Channel (Lbs)		k=.65 (Lbs)	k=.80 (Lbs)	k=1.0 (Lbs)	k=1.2 (Lbs)
12	3,500 *	0.01	3,500 *	3,500 *	3,500 *	3.9	6,640	25,540	25,430	25,240	25,020
18	3,500 *	0.02	3,500 *	3,500 *	3,500 *	5.8	6,580	25,270	25,020	24,610	24,120
24	3,500 *	0.03	3,500 *	3,500 *	3,500 *	7.8	6,510	24,890	24,460	23,750	22,920
30	3,500 *	0.05	3,500 *	3,500 *	3,500 *	9.7	6,410	24,420	23,750	22,690	21,460
36	3,260	0.07	3,260	3,260	3,260	11.6	6,300	23,850	22,920	21,460	19,800
42	2,790	0.10	2,790	2,790	2,790	13.6	6,170	23,190	21,970	20,090	18,010
48	2,440	0.13	2,440	2,440	2,440	15.5	6,030	22,460	20,930	18,620	16,140
60	1,950	0.20	1,950	1,950	1,660	19.4	5,690	20,790	18,620	15,510	12,410
72	1,630	0.28	1,630	1,630	1,150	23.3	5,310	18,920	16,140	12,410	8,990
84	1,400	0.39	1,400	1,270	840	27.2	4,890	16,920	13,630	9,510	6,600
96	1,220	0.50	1,220	970	650	31.0	4,450	14,880	11,220	7,280	5,060
108	1,090	0.64	1,020	770	510	34.9	3,980	12,860	8,990	5,750	3,990
120	980	0.79	830	620	410	38.8	3,560	10,930	7,280	4,660	**
144	810	1.13	570	430	290	46.6	2,870	7,660	5,060	**	**
168	700	1.54	420	320	210	54.3	**	5,630	**	**	**
180	650	1.77	370	280	180	58.2	**	4,900	**	**	**
192	610	2.01	320	240	160	62.1	**	4,310	**	**	**
216	540	2.55	260	190	130	69.8	**	**	**	**	**
240	490	3.15	210	160	100	77.6	**	**	**	**	**

Span or Unbraced Height (In)	Static Beam Load (X-X Axis)						Max. Allowable Load at Slot Face (Lbs)	Column Loading Data			
	Max Allowable Uniform Load (Lbs)	Deflection at Uniform Load (In)	Uniform Load at Deflection					Max. Column Load Applied at C.G.			
			Span/180 Deflection (Lbs)	Span/240 Deflection (Lbs)	Span/360 Deflection (Lbs)	Weight of Channel (Lbs)		k=.65 (Lbs)	k=.80 (Lbs)	k=1.0 (Lbs)	k=1.2 (Lbs)
12	3,480	0.01	3,480	3,480	3,480	1.9	3,850	12,240	11,940	11,480	10,960
18	2,320	0.03	2,320	2,320	2,320	2.9	3,710	11,540	10,960	10,130	9,290
24	1,740	0.06	1,740	1,740	1,740	3.9	3,530	10,690	9,850	8,740	7,710
30	1,390	0.09	1,390	1,390	1,310	4.9	3,330	9,780	8,740	7,470	6,380
36	1,160	0.13	1,160	1,160	910	5.8	3,120	8,880	7,710	6,380	5,310
42	990	0.17	990	990	670	6.8	2,910	8,020	6,800	5,470	4,430
48	870	0.23	870	770	510	7.8	2,710	7,240	6,000	4,690	3,810
60	700	0.35	660	490	330	9.7	2,340	5,910	4,690	3,630	2,960
72	580	0.51	460	340	230	11.6	2,040	4,840	3,810	2,960	2,400
84	500	0.69	340	250	170	13.6	1,800	4,040	3,200	2,480	1,980
96	430	0.90	260	190	130	15.5	1,600	3,480	2,750	2,110	1,670
108	390	1.14	200	150	100	17.5	1,440	3,050	2,400	1,820	**
120	350	1.41	160	120	80	19.4	1,290	2,700	2,110	**	**
144	290	2.03	110	90	60	23.3	1,060	2,180	1,670	**	**
168	250	2.77	80	60	40	27.2	**	1,790	**	**	**
180	230	3.18	70	50	40	29.1	**	**	**	**	**
192	220	3.61	60	50	NR	31.0	**	**	**	**	**
216	190	4.57	50	40	NR	34.9	**	**	**	**	**
240	170	5.65	40	NR	NR	38.8	**	**	**	**	**

7/8" X 1-5/8" X 12ga. Channel

MATERIAL: Low Carbon Steel

FINISH: Plain, Painted Green, or Pre-Galvanized

STOCK LENGTH: 10' or 20' lengths

MANUFACTURER: Haydon Corporation

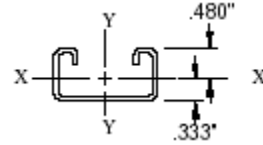
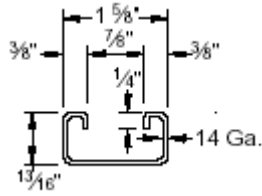
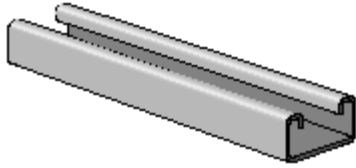

Channel	Weight Lbs/ft.	Areas of Section Sq. in.	X - X Axis			Y - Y Axis		
			Moment of Inertia (I)	Section of Modulus (S)	Radius of Gyration (r)	Moment of Inertia (I)	Section of Modulus (S)	Radius of Gyration (r)
			Inch ⁴	Inch ³	Inch	Inch ⁴	Inch ³	Inch
H-172-OS	1.34	0.397	0.039	0.077	0.313	0.147	0.181	0.609
H-172-OA	2.68	0.794	0.184	0.210	0.481	0.293	0.360	0.607

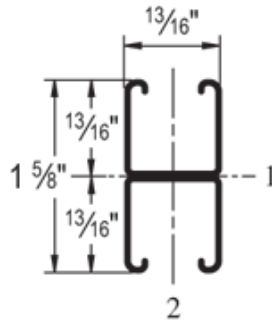
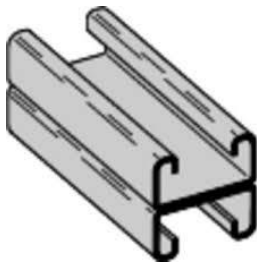

BEAM LOADING

Span or Unbraced Height (In)	Static Beam Load (X-X Axis)						Max. Allowable Load at Slot Face (Lbs)	Column Loading Data			
	Max Allowable Uniform Load (Lbs)	Deflection at Uniform Load (In)	Uniform Load at Deflection					Max. Column Load Applied at C.G.			
			Span/180 Deflection (Lbs)	Span/240 Deflection (Lbs)	Span/360 Deflection (Lbs)	Weight of Channel (Lbs)		k=.65 (Lbs)	k=.80 (Lbs)	k=1.0 (Lbs)	k=1.2 (Lbs)
12	1,280	0.03	1,280	1,280	1,280	1.4	2,550	8,760	8,550	8,250	7,940
18	860	0.06	860	860	760	2.1	2,410	8,280	7,940	7,490	6,950
24	640	0.10	640	640	430	2.8	2,260	7,780	7,350	6,500	5,560
30	510	0.16	510	410	270	3.5	2,060	7,320	6,500	5,330	4,180
36	430	0.23	380	280	190	4.2	1,860	6,620	5,560	4,180	2,960
42	370	0.31	280	210	140	4.9	1,660	5,860	4,630	3,140	2,180
48	320	0.40	210	160	110	5.6	1,460	5,090	3,740	2,400	1,670
60	260	0.63	140	100	70	7.0	1,130	3,640	2,400	1,540	**
72	210	0.90	90	70	50	8.3	890	2,530	1,670	**	**
84	180	1.23	70	50	30	9.7	**	1,860	**	**	**
96	160	1.61	50	40	30	11.1	**	1,420	**	**	**
108	140	2.04	40	30	20	12.5	**	**	**	**	**
120	130	2.51	30	30	20	13.9	**	**	**	**	**
144	110	3.62	20	20	NR	16.7	**	**	**	**	**
168	90	4.92	20	NR	NR	19.5	**	**	**	**	**
180	90	5.65	NR	NR	NR	20.9	**	**	**	**	**
192	80	6.43	NR	NR	NR	22.2	**	**	**	**	**
216	70	8.14	NR	NR	NR	25.0	**	**	**	**	**
240	60	10.05	NR	NR	NR	27.8	**	**	**	**	**

Span or Unbraced Height (In)	Static Beam Load (X-X Axis)						Max. Allowable Load at Slot Face (Lbs)	Column Loading Data			
	Max Allowable Uniform Load (Lbs)	Deflection at Uniform Load (In)	Uniform Load at Deflection					Max. Column Load Applied at C.G.			
			Span/180 Deflection (Lbs)	Span/240 Deflection (Lbs)	Span/360 Deflection (Lbs)	Weight of Channel (Lbs)		k=.65 (Lbs)	k=.80 (Lbs)	k=1.0 (Lbs)	k=1.2 (Lbs)
12	1,850 *	0.01	1,850 *	1,850 *	1,850 *	2.8	4,480	18,240	18,090	17,840	17,550
18	1,850 *	0.03	1,850 *	1,850 *	1,850 *	4.2	4,390	17,880	17,550	17,030	16,410
24	1,760	0.06	1,760	1,760	1,760	5.6	4,260	17,390	16,830	15,940	14,930
30	1,410	0.09	1,410	1,410	1,290	7.0	4,110	16,780	15,940	14,650	13,220
36	1,180	0.13	1,180	1,180	890	8.3	3,930	16,060	14,930	13,220	11,390
42	1,010	0.18	1,010	980	660	9.7	3,740	15,260	13,810	11,700	9,560
48	880	0.23	880	750	500	11.1	3,540	14,380	12,620	10,160	7,810
60	710	0.37	640	480	320	13.9	3,110	12,470	10,160	7,250	5,040
72	590	0.53	450	340	220	16.7	2,690	10,470	7,810	5,040	3,500
84	500	0.72	330	250	160	19.5	2,290	8,520	5,780	3,700	**
96	440	0.94	250	190	130	22.2	1,960	6,700	4,430	2,830	**
108	390	1.18	200	150	100	25.0	1,700	5,300	3,500	**	**
120	350	1.46	160	120	80	27.8	1,480	4,290	2,830	**	**
144	290	2.10	110	80	60	33.4	**	2,980	**	**	**
168	250	2.86	80	60	40	38.9	**	**	**	**	**
180	240	3.29	70	50	NR	41.7	**	**	**	**	**
192	220	3.74	60	50	NR	44.5	**	**	**	**	**
216	200	4.74	NR	NR	NR	50.0	**	**	**	**	**
240	180	5.85	NR	NR	NR	55.6	**	**	**	**	**

DURA-BLOK - Rooftop Supports

Base with Galvanized Channel - 1" high

Dimensions: 5" High x 6" Wide x length (overall length)

Material: 100% recycled rubber, UV resistant



Part No.	Height	Width	Overall Length (in.)	Weight Each (Lbs.)	Ultimate Load Capacity Lbs. (Uniform Load)
DB5	5"	6"	4.8"	2.75	500
DB10	5"	6"	9.6"	5.28	500
DB20	5"	6"	20.2"	10.63	1000
DB30	5"	6"	30.8"	15.99	1500
DB40	5"	6"	41.4"	21.34	2000
DB48	5"	6"	52.0"	26.70	2500

DURA-BLOK DB-Series channel support is designed for superior support of piping systems, cable tray, HVAC equipment, walkway systems and many other applications. The DURA-BLOK is UV resistant and suitable for installation on any type of roofing material or other flat surfaces. For sloped roofs see adjustable hinge fitting.

STRUT FITTINGS

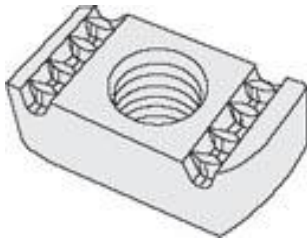

Strut Nut without Spring

MATERIAL: Low Carbon Steel

FINISH: Electro-Galvanized

* Available in Stainless Steel upon request

Thread Size	Std. Package	Thickness	Weight Each	
			Lbs.	Kg.
#8-32	100	1/4"	.07	.03
#10-24	100	1/4"	.07	.03
#10-32	100	1/4"	.07	.03
1/4"*	100	1/4"	.07	.03
5/16"	100	1/4"	.07	.03
3/8"*	100	3/8"	.10	.04
7/16"	100	3/8"	.10	.04
1/2"*	100	1/2"	.13	.05
5/8"	100	1/2"	.15	.06
3/4"	100	1/2"	.15	.06
7/8"	100	1/2"	.15	.06



Shallow Strut Nut without Spring

MATERIAL: Low Carbon Steel

FINISH: Electro-Galvanized

Thread Size	Std. Package	Thickness	Weight Each	
			Lbs.	Kg.
1/2"	100	3/8"	.09	.04
5/8"	100	3/8"	.11	.05
3/4"	100	3/8"	.09	.04



Strut Nut with Spring

MATERIAL: Low Carbon Steel

FINISH: Electro-Galvanized

* Available in Stainless Steel upon request

Thread Size	Std. Package	Thickness	Weight Each	
			Lbs.	Kg.
#8-32	100	1/4"	.06	.03
#10-24	100	1/4"	.06	.03
#10-32	100	1/4"	.06	.03
1/4"*	100	1/4"	.06	.03
5/16"	100	1/4"	.07	.03
3/8"*	100	3/8"	.09	.04
7/16"	100	3/8"	.09	.04
1/2"*	100	1/2"	.12	.05
5/8"	100	1/2"	.13	.06
3/4"	100	1/2"	.13	.06
7/8"	100	1/2"	.13	.06

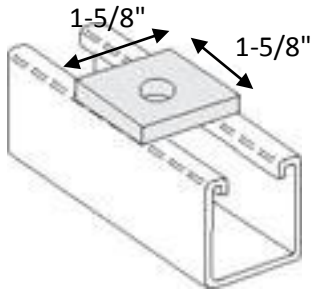

Rod Size	Std. Package	Weight Each	
		Lbs.	Kg.
1/4"	100	.18	.08
3/8"	100	.17	.08
1/2"	100	.17	.08
5/8"	100	.16	.07
3/4"	100	.16	.07

Square Washer

MATERIAL: Low Carbon Steel

SIZE: 1-5/8" X 1-5/8" X 1/4"

FINISH: Electro-Galvanized

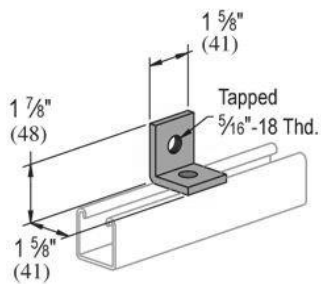

2-HOLE

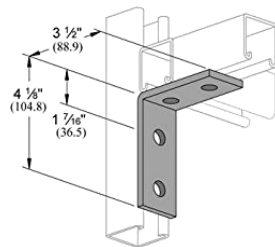

4-HOLE

Description	Thickness	Std. Packaging	Wt. Each (In Lbs.)
2-Hole	1/4"	50	.36
4-Hole	1/4"	50	.78

90° Fittings

MATERIAL: Low Carbon Steel

FINISH: Electro-Galvanized

STRUT CLAMPS

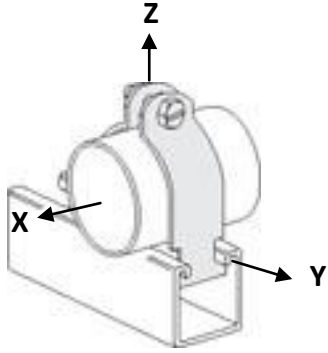

Iron Pipe Strut Clamp

MATERIAL: Low Carbon Steel

FINISH: Electro-Galvanized

Pipe Size	OD Size	Material Gauge	Max Rec. Loads (in lbs.)			Wt. Each (in lbs.)
			X	Y	Z	
3/8	-	16	50	50	400	.10
1/2	-	16	50	50	400	.10
3/4	-	14	75	75	600	.14
1	-	14	75	75	600	.17
1-1/4	-	14	75	75	600	.21
1-1/2	-	12	125	125	800	.30
2	2-3/8	12	125	125	800	.35
2-1/2	2-7/8	12	125	125	800	.39
3	3-1/2	12	125	125	800	.46
3-1/2	4	11	150	200	1000	.65
4	4-1/2	11	150	200	1000	.66
5	-	11	150	200	1000	.79
6	6-5/8	11	150	200	1000	1.00
8	8-5/8	11	200	250	1000	1.14
10	10-3/4	11	200	250	1000	1.43
12	12-3/4	11	200	250	1000	1.74

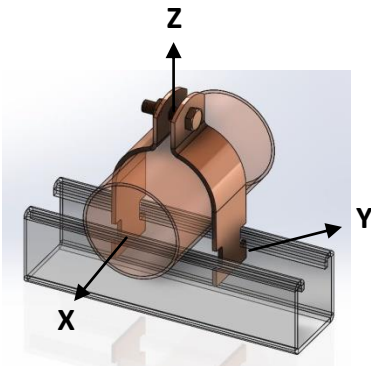

Copper Tubing Strut Clamp

MATERIAL: Low Carbon Steel

FINISH: Copper

Pipe Size	Material Gauge	Max Rec. Loads (in lbs.)			Wt. Each (in lbs.)
		X	Y	Z	
1/4	16	50	50	400	.09
3/8	16	50	50	400	.09
1/2	16	50	50	400	.09
3/4	16	50	50	400	.10
1	14	75	75	600	.14
1-1/4	14	75	75	600	.16
1-1/2	14	75	75	600	.17
2	12	125	125	800	.29
2-1/2	12	125	125	800	.35
3	12	125	125	800	.40
3-1/2	12	150	200	1000	.51
4	12	150	200	1000	.61
5	11	150	200	1000	.74
6	11	200	250	1000	.94

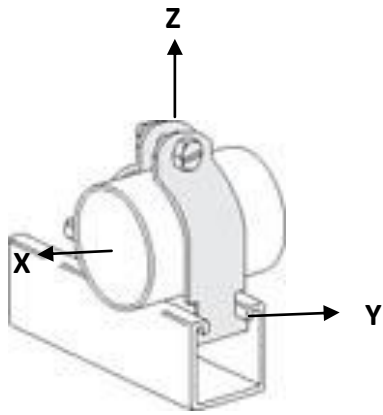

O.D. Tube Strut Clamp

MATERIAL: Low Carbon Steel

FINISH: Electro-Galvanized

Pipe Size	Material Gauge	Max Rec. Loads (in lbs.)			Wt. Each (in lbs.)
		X	Y	Z	
1/4	16	50	50	400	.09
3/8	16	50	50	400	.09
1/2	16	50	50	400	.10
5/8	16	50	50	400	.10
3/4	16	50	50	400	.10
7/8	16	50	50	400	.10
1	14	75	75	600	.13
1-1/8	14	75	75	600	.14
1-1/4	14	75	75	600	.14
1-3/8	14	75	75	600	.16
1-1/2	14	75	75	600	.16
1-5/8	14	75	75	600	.17
1-3/4	12	125	125	800	.27
1-7/8	12	125	125	800	.28
2	12	125	125	800	.28
2-1/8	12	125	125	800	.29
2-1/4	12	125	125	800	.32
2-1/2	12	125	125	800	.34
2-5/8	12	125	125	800	.35
2-3/4	12	125	125	800	.37
3	12	125	125	800	.39
3-1/8	12	125	125	800	.40
3-1/4	12	125	125	800	.42
3-3/8	12	125	125	800	.43
3-5/8	11	150	200	1000	.51
3-3/4	11	150	200	1000	.53
3-7/8	11	150	200	1000	.54
4-1/8	11	150	200	1000	.57
4-1/4	11	150	200	1000	.59
4-3/8	11	150	200	1000	.60
4-5/8	11	150	200	1000	.52
4-3/4	11	150	200	1000	.64
4-7/8	11	150	200	1000	.65
5	11	150	200	1000	.67
5-1/8	11	150	200	1000	.68
5-1/4	11	150	200	1000	.70
5-3/8	11	150	200	1000	.71
5-1/2	11	150	200	1000	.72
5-5/8	11	150	200	1000	.85
5-3/4	11	150	200	1000	.87
5-7/8	11	150	200	1000	.88
6	11	150	200	1000	.90
6-1/8	11	200	250	1000	.94
6-1/4	11	200	250	1000	.93
6-3/8	11	200	250	1000	.95

O.D. Tube Strut Clamp Continued

MATERIAL: Low Carbon Steel

FINISH: Electro-Galvanized

Pipe Size	Material Gauge	Max Rec. Loads (in lbs.)			Wt. Each (in lbs.)
		X	Y	Z	
6-1/2	11	200	250	1000	.98
6-3/4	11	200	250	1000	.99
6-7/8	11	200	250	1000	1.00
7	11	200	250	1000	1.01
7-1/8	11	200	250	1000	1.02
7-1/4	11	200	250	1000	1.04
7-3/8	11	200	250	1000	1.07
7-1/2	11	200	250	1000	1.09
7-5/8	11	200	250	1000	1.10
7-3/4	11	200	250	1000	1.12
7-7/8	11	200	250	1000	1.13
8	11	200	250	1000	1.15
8-1/8	11	200	250	1000	1.17
8-1/4	11	200	250	1000	1.18
8-3/8	11	200	250	1000	1.20
8-1/2	11	200	250	1000	1.21

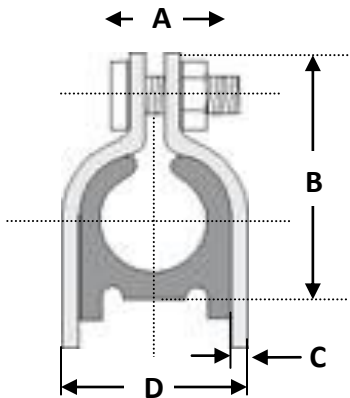

O.D. Clamp with Cushion

MATERIAL: Low Carbon Steel

FINISH: Western Gold

CUSHION MATERIAL: Multi-Flex TES

A9110 EV1 Black, in accordance with ASTM D4474 TES 0130 A90000

TEMPERATURE RANGE: -65°F to 275°F (-54°C to 135°C)

O.D Size (A)	Nom. Tube Size	B	C	D	Wt. Each (in lbs.)
1/4	1/8	1-1/16	.060	1/8	.12
3/8	1/4	1-1/4	.060	5/8	.13
1/2	3/8	1-3/8	.060	3/4	.13
5/8	1/2	1-1/2	.060	7/8	.15
3/4	5/8	1-3/4	.075	1-1/8	.21
7/8	3/4	1-7/8	.075	1-1/4	.22
1-1/4	1	2-1/16	.075	1-1/8	.29
1-3/8	1-1/4	2-7/16	.075	1-3/4	.33
1-5/8	1-1/2	3	.105	2-1/4	.42
2-1/8	2	3-3/8	.105	2-3/4	.50
2-5/8	2-1/2	3-7/8	.105	3-1/4	.62
3-1/8	3	4-5/16	.105	3-3/4	.66
4-1/8	4	5-1/2	.125	4-3/4	.88

BEAM CLAMPS

Strut Beam Clamp (Window Clamp)

MATERIAL: 1/4"

FINISH: Electro-Galvanized

Size	Max Rec. Load/Lbs	Wt. Each (in Lbs.)
1-5/8"	1000	.80
3-1/4"	1000	.88

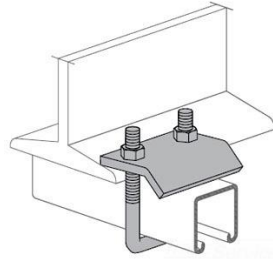

1-5/8"
(also to be used for 7/8")

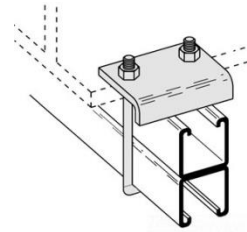

3-1/4"
(Back-to-Back)

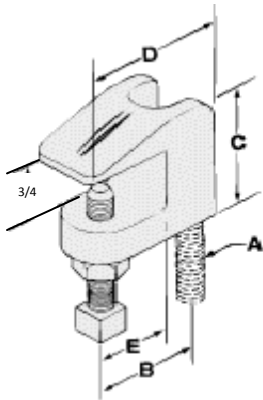

Rod Size (A)	B	C	D	E	Max Pipe Size	Max Rec. Load/lbs.	Wt. Each (in lbs.)
1/4	7/8	1-1/2	1-5/8	1/2	-	250	.34
3/8	7/8	1-1/2	1-5/8	1/2	4	400	.33
1/2	1	1-1/2	1-11/16	1/2	8	500	.34
5/8	1-1/16	1-1/2	1-7/8	5/8	8	600	.39
3/4	1-5/16	1-3/4	2-3/8	5/8	8	800	.63
7/8	1-5/16	1-3/4	2-3/8	5/8	8	1200	.60

Beam Clamp

MATERIAL: Malleable iron with hardened steel cup point set screw and locknut.

FINISH: Plain or Electro-Galvanized

Set Screw Torque		
Nominal Thread Size	3/8	1/2
Rec. Torque (in lbs.)	60	125

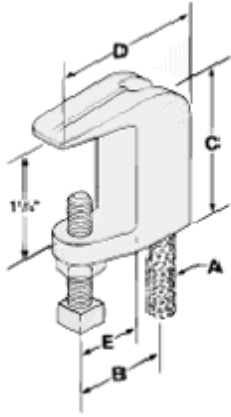

Rod Size (A)	B	C	D	E	Max Pipe Size	Max Rec. Load/lbs.	Wt. Each (in lbs.)
3/8	1	1-7/8	1-5/8	1/2	4	400	.37
1/2	1	1-7/8	1-5/8	1/2	8	500	.35
5/8	1-3/8	2-5/16	2-1/4	3/4	5	850	.74
3/4	1-1/2	2-3/8	2-3/8	3/4	6	900	.87

Wide Mouth Beam Clamp

MATERIAL: Malleable iron with hardened steel cup point set screw and locknut.

FINISH: Plain or Electro-Galvanized

Set Screw Torque		
Nominal Thread Size	3/8	
Rec. Torque (in lbs.)	60	

CLEVIS HANGERS

Function: Recommended for the suspension of non-insulated, stationary pipe lines.

APPROVALS: U.L. - U.L.C. listed (sizes 2-1/2" - 8" excluding 7") and FM approved (3/4" - 2" galv only. 2-1/2" - 8" plain and galv.). Complies with Federal Specification WW-H-171-E (Type# 1), A-A-1192 A (Type# 1) and Manufacturers' Standardization Society MSS SP-58 2) and SP-69(Type# 1). Approvals do not apply to 11RR.

MATERIAL: Steel

MAXIMUM TEMPERATURE: 650 degrees Fahrenheit (343 degrees C)

ORDERING: Specify pipe size, material, finish type, and figure number.

Note: For sizes 20" and larger a spacer sleeve is added over the cross bolt. Upper locknut must be tightened securely to assure proper hanger performance. Stainless Steel hangers are recommended for applications where protection from a corrosive environment is required

Do not use dimensions shown for NFPA hanger sizes

- 11B – Plain Carbon Steel
- 11G – Electro-Galvanized
- 11SS – T-304 Stainless
- 11SX – T-316 Stainless
- Manufacturer: Empire

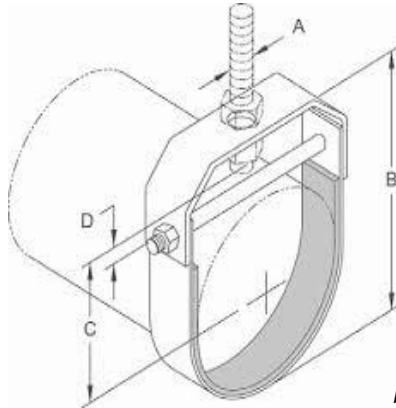

Pipe Size	Rod Size (A)	B	C	Adj. D	E	Adj. F	Design Load	Approx. Wt./100
1/2	3/8-16	2-1/8	1-3/4"	15/16	2-1/2	7/16"	730	25
3/4	3/8-16	2-1/2	2	1-1/8	2-1/2	1/2	730	29
1	3/8-16	2-7/8	2-1/4	1-3/8	2-1/2	5/8	730	35
1-1/4	3/8-16	3-1/2	2-11/16	1-13/16	2-1/2	7/8	730	40
1-1/2	3/8-16	4	3-1/16	2-1/4	2-1/2	1-3/16	730	42
2	3/8-16	4-1/2	3-5/16	2-1/2	2-1/2	1-5/8	730	52
2-1/2	1/2-13	5-3/8	3-15/16	3-1/16	2-1/2	2	1350	90
3	1/2-13	6-1/2	4-3/4	3-15/16	2-1/2	2	1350	110
3-1/2	1/2-13	7-1/4	5-1/4	4-1/16	2-1/2	2	1350	142
4	5/8-11	7-3/4	5-1/2	5-1/2	2-1/2	2	1430	132
5	5/8-11	8-3/4	6-1/8	6	2-1/2	2	1430	215
6	3/4-10	10-15/16	6-15/16	7	3	2	1940	320
8	3/4-10	12-3/4	8-7/16	7-1/8	3-1/2	2-15/16	2000	485
10	7/8-9	15-1/8	9-3/4	8-3/8	3-1/2	2-5/16	3600	846
12	7/8-9	17-1/2	11-1/8	9-11/16	3-1/2	2-5/8	3800	1083
14	1-8	19-3/8	12-3/8	10-5/8	4	2-7/8	4200	1432
16	1-8	21-3/8	13-3/8	11-9/16	4	2-11/16	4600	2200
18	1-8	25	16	14-3/16	4-1/2	3-15/16	4800	2500
20	1-1/4-7	28-3/4	17-3/4	16-5/8	5	5-3/8	4800	4400
24	1-1/4-7	32-3/4	19-3/4	18-5/8	5	5-3/8	4800	5000
30	1-1/4-7	39-15/16	24-15/16	22-3/4	5	6-1/4	6000	6600
36	1-1/4-7	46	28	25	5	5-7/16	6000	8474

Note: Use of an upper locknut ensures proper performance.

LIGHT DUTY CLEVIS HANGERS

110B-Plain Carbon Steel

110G-Electro-Galvanized

110GI-Electro-Galvanized, Imported

Manufacturer: Empire

FUNCTION: Recommended for the suspension of light stationary pipe allowing for vertical adjustment

APPROVALS: Complies with Federal Specification WW-H-171-E (Type#12) and Manufacturers' Standardization Society MSS SP-58 and SP-69 (Type#1). Galvanized only.

MATERIAL: Steel

MAXIMUM TEMPERATURE: 650 degrees Fahrenheit (343 degrees C)

ORDERING: Specify pipe size, material, finish type, and figure number.

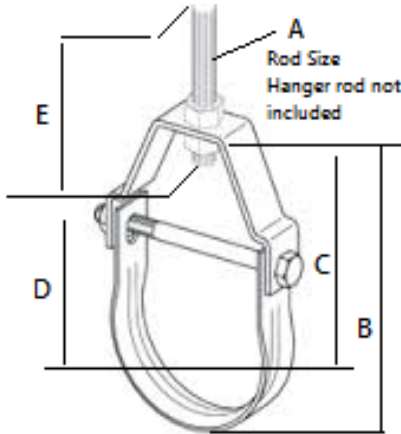

Pipe Size	Rod Size (A)	B	C	Rod Take-Out D	E	Adj. F	Design Load	Wt. Each (lbs.)
1/2	3/8	1-5/16	1-1/2	13/16	2-1/2	7/16"	150	13
3/4	3/8	2-5/16	1-3/4	1	2-1/2	7/16"	250	22
1	3/8	2-3/4	2-1/16	1-3/8	2-1/2	9/16"	250	24
1-1/4	3/8	3-5/16	2-7/16	1-3/4	2-1/2	13/16"	250	29
1-1/2	3/8	3-5/8	2-5/8	2	2-1/2	1"	250	30
2	3/8	4-13/16	3-5/8	2-15/16	2-1/2	1-3/4"	250	35
2-1/2	1/2	5-13/16	4-5/16	3-7/16	2-1/2	2"	350	82
3	1/2	6-7/16	4-5/8	3-3/4	2-1/2	2"	350	91
3-1/2	1/2	6-15/16	4-15/16	4	2-1/2	2"	350	98
4	1/2"	7-3/4	5-1/2	4-9/16	2-1/2	2-3/16"	400	132

Note: Upper locknut must be tightened securely to assure proper hanger performance. Conduit comes in various outside diameters. Verify outside diameter of conduit is equal to outside diameter of schedule 40 steel pipe.

Note: Use of an upper locknut ensures proper performance.

B	C	D	E	F
Bottom of pipe to top of hanger	center to top of hanger	Rod take-out center of pipe to bottom of rod hanger	Minimum thread length of hanger rod	Adjustment top of cross bolt to bottom of hanger rod nut inside the hanger

BAND (RING) HANGERS

Fig. 200 - Adjustable Band Hanger "Ring Hanger Electro-Galvanized

Fig. 200F - Adjustable Band Hanger w/ Felt Lining for Copper Tubing

Fig. 200C - Adjustable Band Hanger w/ Plastic Coated

Fig. 200S - Adjustable Band Hanger w/ Removable Nut (Sizes 1" - 2")

Manufacturer: Empire

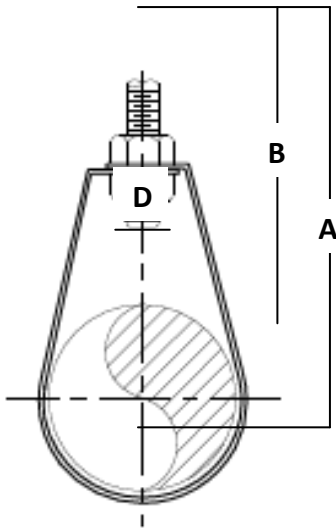

FUNCTION: For Fire Sprinkler and other general purposes. Knurled swivel nut design permits hanger adjustment after installation

APPROVALS: Underwriters Laboratories listed 1/2" thru 8" in the USA (UL) & Canada (cUL) for steel and CPVC plastic pipe and factory mutual engineering approved. Conforms to Federal specifications WW-H-171E & A-A-1192A

MATERIAL: Steel, Pre- Galvanized to G90 Specifications

MAXIMUM TEMPERATURE: 650 degrees Fahrenheit (343 Degrees C)



A	B	D
Overall Height	Center of pipe to top of knurled hanger rod nut.	Top of pipe to bottom of hanger rod nut.

Pipe Size	Rod Size	A	B	D	Max. Rec. Load (lbs.)	Approx Wt./100 (lbs.)
1/2	3/8	3-1/8	2-5/8	1-11/32	400	11
3/4	3/8	3-1/8	2-1/2	1-1/16	400	11
1	3/8	3-3/8	2-5/8	1-1/8	400	12
1 1/4	3/8	3-3/4	2-7/8	1-5/32	400	13
1 1/2	3/8	3-7/8	2-7/8	1-3/16	400	14
2	3/8	4-1/2	3	13/16	400	15
2-1/2	3/8	5-5/8	4-1/8	1-7/16	600	27
3	3/8	5-7/8	4	1-1/4	600	29
3-1/2	3/8	7-3/8	5-1/4	2-3/16	600	34
4	3/8	73/8	5	1-3/8	1000	35
5	1/2	9-7/8	6-1/4	3-11/32	1250	66
6	1/2	10-1/8	6-3/4	2-7/32	1250	73
8	1/2	13-1/8	8-3/4	3-7/32	1250	136

BAND (RING) HANGERS - COPPER

31CTP - Adjustable Swivel Hanger for Copper Tubing

31CTI - Adjustable Swivel Hanger for Copper Tubing - Plastic Coated

Manufacturer: Empire

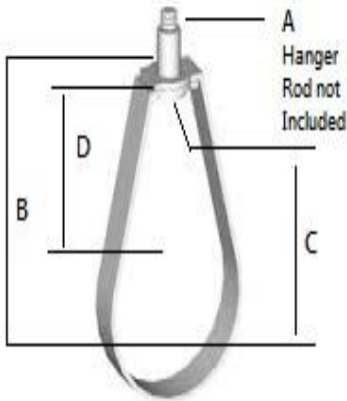

FUNCTION: Recommended for the suspension of copper tubing, allowing for vertical adjustment. Available with plastic coating to provide additional separation between tubing and hanger.

APPROVALS: Conforms to Federal Specifications WW-H-171E & A-A-1192A

MATERIAL: Steel

STANDARD FINISH: DURA-COPPER



A	B	C	D
Rod Size Hanger Rod Not Included.	Center of Pipe to top of knurled hanger rod nut.	Rod Take-Out Center of pipe to bottom of hanger rod.	Top of pipe to bottom of hanger rod nut.

Pipe Size	Rod Size	A	B	D	Max. Rec. Load (lbs.)	Approx Wt./100 (lbs.)
1/2	3/8	3/8-16	1-1/8"	31/32"	180	8
3/4	3/8	3/8-16	1-5/16"	1-1/32"	180	10
1	3/8	3/8-16	1-9/16"	1-5/32"	180	10
1-1/4	3/8	3/8-16	1-9/16"	1"	180	12
1-1/2	3/8	3/8-16	2"	1-5/16"	180	12
2	3/8	3/8-16	2-1/8"	1-3/16"	180	12
2-1/2	1/2	1/2-13	2-9/16"	1-3/8"	200	31
3	1/2	1/2-13	3-3/4"	1-1/4"	250	33
3-1/2	1/2	1/2-13	3-1/4"	1-1/2"	300	39
4	1/2	1/2-13	3-9/16"	1-9/16"	360	40
5	1/2	1/2-13	4-5/16"	1-25/32"	480	95
6	1/2	1/2-13	5-3/16"	2-1/8"	630	118

PIPE ROLLER HANGERS

272B-Plain Carbon Steel

272G-Electro-Galvanized

272SS-T-304 Stainless Steel

272SX-T-316 Stainless Steel

Finish: Plain

Manufacturer: Empire

FUNCTION: For Supporting pipe where movement may occur due to thermal expansion

APPROVALS: Conforms to Federal Specifications WW-H-171E & A-A-1192A, and manufacturers Standardization Society ANSI/MSS

MATERIAL: Cast Iron and Steel

SIZING: Pipe roller size shown is for bare pipe. For proper sizing with insulation, refer to pipe roller selection guide.

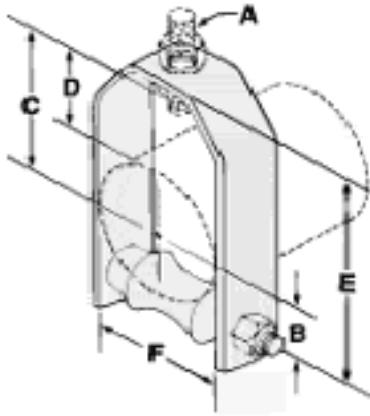

A	B	C	D	E
Rod Size Hanger Rod Not Included	Center of Axel to Center of Pipe.	Center of Axel to top of hanger steel.	Rod Take-Out Center of pipe to bottom of hanger rod	Adjustment top of pipe to bottom of hanger rod nut.

Pipe Roller Size	Rod Size A	B	C	D	E	F	Max. O.D. of Covering	Max. Rec. Load/lbs.	Wt. Each (lbs.)
2	3/8"	1-9/16"	4-3/4"	2-3/8"	1-7/16"	2-7/8"	2-5/8"	150	123
2-1/2	1/2	1-7/8"	6	3-3/16	2	3-1/4	3	225	178
3	1/2	2-3/16"	6-5/8	3-1/2	2	3-7/8	3-5/8	310	206
3-1/2	1/2	2-1/2"	7-1/4	3-3/4	2	4-3/8	4-1/8	390	267
4	5/8	2-3/4	7-7/8	4	2	4-7/8	4-11/16	475	344
5	5/8	3-3/8"	9-3/16	4-9/16	2	5-15/16	5-3/4	685	600
6	3/4	3-15/16"	10-3/8	5-1/16	2	7	6-3/4	780	800
8	3/4	5-1/16"	12-5/8	6-1/16	2	9	8-3/4	780	1300
10	7/8	6-1/4"	14-15/16	7-3/16	2-1/16	11-1/8	10-3/4	965	1600
12	7/8	7-3/8"	17-3/8	8-3/8	2-1/4	13-3/8	13	1200	2600
14	1	8-1/4"	19	8-3/4	2-1/4	14-1/2	14-1/4	1200	3400
16	1	9-1/4"	20-3/4	9-3/4	2	16-3/8	16-1/8	1200	3900
18	1	10-3/8"	23-11/16	11-7/16	2-11/16	18-3/8	18-1/8	1400	4900
20	1-1/4	11-1/2"	25-7/8	12-1/4	2-1/2	20-3/8	20-1/8	1600	6686
24	1-1/2	13-13/16	31-9/16	15	3-1/2	24-5/8	24-3/8	1800	11630

RISER CLAMPS

50B-Plain Carbon Steel

50G-Electro-Galvanized

50PC-Plastic Coated

50SS-T-304 Stainless

50SX-T-316 Stainless

Manufacturer: Empire

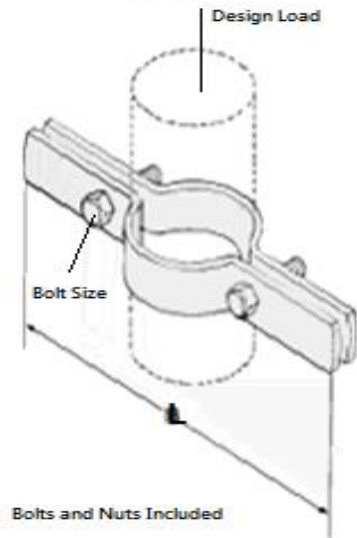

FUNCTION: Used for supporting vertical piping

APPROVALS: Underwriters Laboratories Listed in the USA (UL)
Conforms to Federal Specifications WW-H-171E & A-A-1192A,
Type 8 and Manufacturers Standardization Society ANSI/MSS SP-
69 & SP-58, Type 8

MATERIAL: Steel

MAXIMUM TEMPERATURE: 650 degrees Fahrenheit

Pipe Size	L	Bolt Size	Design Load	Wt. Each (lbs.)
1/2	9	3/8 x 1-1/4	255	101
3/4	9-1/4	3/8 x 1-1/4	255	105
1	9-9/16	3/8 x 1-1/4	255	109
1-1/4	10	3/8 x 1-1/2	255	112
1-1/2	10-1/4	3/8 x 1-1/2	255	113
2	10-3/4	3/8 x 1-1/2	255	165
2-1/2	11-1/4	3/8 x 1-1/2	390	180
3	11-15/16	3/8 x 1-1/2	530	195
3-1/2	12-3/8	3/8 x 1-3/4	670	217
4	12-7/8	1/2 x 1-3/4	810	228
5	14	1/2 x 1-3/4	1160	480
6	15-3/16	1/2 x 2	1570	526
8	17-3/4	5/8 x 2-1/2	2500	957
10	19-7/16	5/8 x 2-1/2	2500	1101
12	21-11/16	5/8 x 3	2700	1622
14	23-9/16	5/8 x 3	2700	1732
16	26-3/8	3/4 x 3-1/4	2900	2959
18	28-7/8	3/4 x 3-1/4	2900	3235
20	30-7/8	3/4 x 3-1/2	2900	3568
24	34-7/8	7/8 x 3-1/2	2900	4064
30	40-3/4	7/8 x 3-1/2	2900	6016

RISER CLAMPS - COPPER

50CTP - Copper Tubing Riser Clamp

50CTI - PVC Coated Copper Tubing Riser Clamp

Finish: DURA-COPPER

Manufacturer: Empire

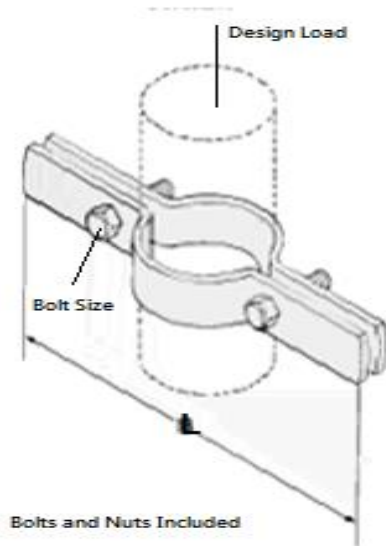

FUNCTION: Used for supporting vertical copper tubing

APPROVALS: Conforms to Federal Specifications WW-H-171E & A-A-1192A Type 8 and Manufacturers Standardization Society ANSI/ MSS SP-69 & SP-58 Type 8.

MATERIAL: Steel



Pipe Size	L	Bolt Size	Design Load	Wt. Each (lbs.)
1/2"	8-3/4"	5/16" x 1"	75	72
3/4"	9-1/16"	5/16" x 1"	75	73
1"	9-5/16"	3/8" x 1"	120	74
1-1/4"	9-5/8"	3/8" x 1"	150	77
1-1/2"	9-3/4"	3/8" x 1-1/4"	150	111
2"	10-7/16"	3/8" x 1-1/4"	150	120
2-1/2"	10-15/16"	3/8" x 1-1/4"	300	128
3"	11-7/16"	3/8" x 1-1/4"	300	136
3-1/2"	11-15/16"	3/8" x 1-1/4"	300	145
4"	12-1/2"	1/2" x 1-3/4"	300	170
5"	13-5/8"	1/2 x 2"	500	355
6"	14-5/8"	1/2" x 2"	500	386

PRO-SHIELDS

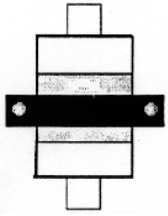

FUNCTION: 360 degree thermal hanger shield for pipe support applications. Provide insulation and vapor barrier for a wide range of pipe systems operating between 20 degrees Fahrenheit and 1200 degrees Fahrenheit. Pro-Shield are suitable for indoor use with any type of clamp, band-type hangers, flat surfaces and on correctly sized roller hangers.

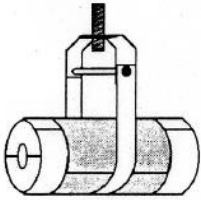

APPROVALS: Meets the MSS standard for a Type 40 shield per MSS SP-58, Paragraph 9.2.2.

MATERIAL: 140 PSI Calcium silicate meeting ASTM C-533, C-585, C-795, E-84. Adhesive meeting NFPA 90-A, ASTM E-84. Galvanized steel shield ASTM A-527. Vapor Barrier meeting ASTM D-774, D-828, and E-84. Structural insert (12" pipe and larger) minimum 450 PSI meeting ASTM C-533, C-795, E-84.

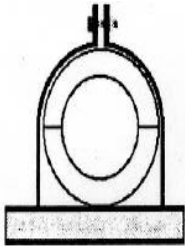

ORDERING: Specify Size:

- Pipe Size - Copper or Iron
- Insulation thickness

MANUFACTURER: Value Engineered Products

Pipe Size	1/2" to 1-1/2"	2" to 5"	6" to 10"	12" & 14"	16" to 24"
Insulation	6" 150mm	6" 150mm	9" 230mm	12" 300mm	18" 450mm
Shield Length	4" 100mm	4" 100mm	6" 150mm	9" 230mm	15" 375mm
Shield Gauge	22 ga. .9mm	20 ga. 1mm	16 ga. 1.6mm	16 ga. 1.6mm	14 ga. 2mm

Nominal Steel Pipe Size	Spacing		Maximum Load		Roller
	Feet	Meters	Band	Trapeze	
2	10	3.0	240	190	190
4	10	3.0	800	630	650
6	10	3.0	1625	1250	975
8	10	3.0	1850	1250	N/R
10	10	3.0	2150	1375	N/R
12	10	3.0	2900	2100	N/R
14	10	3.0	4000	3750	N/R
16	10	3.0	5250	N/R	N/R
18	10	3.0	6250	N/R	N/R
20	10	3.0	7950	N/R	N/R

Spans are based on MSS SP-69 Table 5, Type 40 Shields

When using the recommended maximum load to determine hanger spacing, the load must include pipe weight, weight of transported media and any valves or fittings which may affect the total weight of that span of pipe.

QUIK-SHIELDS

FUNCTION: 180 degree thermal hanger shield for pipe support applications. Provide insulation and vapor barrier for a wide range of pipe systems. Quik-Shield are suitable for indoor use with clevis, band-type hangers, flat surfaces and on correctly sized roller hangers. Available for pipe from 1/2 inch through 30 inches. Insulation thickness from 1/2 inch through 4 inches. To assure proper support in all situations, high density 450 PSI inserts are installed on units for 10" pipe with 1" wall thickness and on all units for 12" pipe and larger.

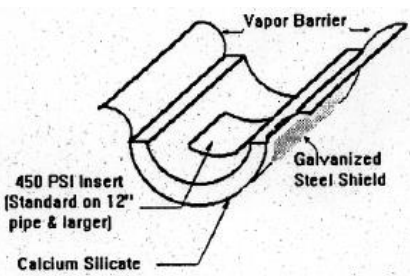
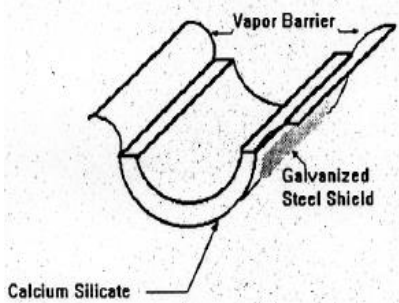

APPROVALS: Meets the MSS standard for a Type 40 shield per MSS SP-69, Table 5

MATERIAL: 140 PSI Calcium silicate meeting ASTM C-533, C-585, C-795, E-84. Adhesive meeting NFPA 90-A, ASTM E-84. Galvanized steel shield ASTM A-527. Vapor Barrier meeting ASTM D-774, D-828, and E-84. Structural insert (12" pipe and larger) minimum 450 PSI meeting ASTM C-533, C-795, E-84.

MANUFACTURER: Value Engineered Products

Pipe Size	1/2" to 1-1/2"	2" to 5"	6" to 10"	12" & 14"	16" to 24"
Insulation	6" 150mm	6" 150mm	9" 230mm	12" 300mm	18" 450mm
Shield Length	4" 100mm	4" 100mm	6" 150mm	9" 230mm	15" 375mm
Shield Gauge	22 ga. .9mm	20 ga. 1mm	16 ga. 1.6mm	16 ga. 1.6mm	14 ga. 2mm

Nominal Steel Pipe Size	Spacing		Maximum Load		Roller
	Feet	Meters	Band	Trapeze	
2	10	3.0	240	190	190
4	10	3.0	800	630	650
6	10	3.0	1625	1250	975
8	10	3.0	1850	1250	N/R
10	10	3.0	2150	1375	N/R
12	10	3.0	2900	2100	N/R
14	10	3.0	4000	3750	N/R
16	10	3.0	5250	N/R	N/R
18	10	3.0	6250	N/R	N/R
20	10	3.0	7950	N/R	N/R

Spans are based on MSS SP-69 Table 5, Type 40 Shields

When using the recommended maximum load to determine hanger spacing, the load must include pipe weight, weight of transported media and any valves or fittings which may affect the total weight of that span of pipe.

INSULATION PROTECTION SHIELDS

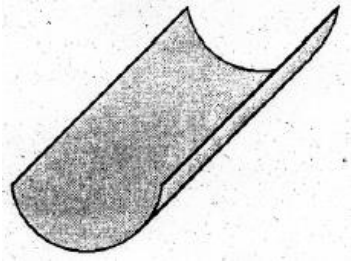

FUNCTION: All insulation systems require steel shields either with or without high density inserts to be installed at each point the pipe is supported. Shield lengths and gauges may vary widely between specifications, for this reason there are a variety of shield lengths and gauges to meet the industry's different requirements. All shields are precision stamped or rolled to meet ASTM C-585 dimensional standards and match the various pipe insulation outside diameters.

MATERIAL: G-90 galvanized per ASTM A-527. or 304 or 316 stainless steel available.

MANUFACTURER: Value Engineered Products

Pipe Size	Shield Gauge	Shield Length
1/2" - 3-1/2"	18	12"
4"	16	12"
5" and 6"	16	18"
8" - 14"	14	24"
16" - 24"	12	24"

The MSS SP-58 and SP-69 list the following shield lengths and gauges for use with insulation having a compressive strength of 15 PSI when the system uses clevis hangers with a maximum span of 10 feet.

HANGER SIZING GUIDE

Reference Guide For Matching Insulated Pipe Supports with Standard Hanger ID's

Outcome - use OD strut Clamps

Minimum Hanger Inside Diameter in Inches				
Iron Pipe Size	X 1/2	X 1	X 1-1/2	X 2
1/2	2"	3"	4-1/8"	5-1/8"
3/4	2-1/4"	3"	4-1/8"	5-1/8"
1	2-1/2"	3-5/8"	4-5/8"	5-5/8"
1-1/4	3"	3-5/8"	5-1/8"	5-5/8"
1-1/2		4-1/8"	5-1/8"	6-3/4"
2	3-5/8"	4-5/8"	5-5/8"	6-3/4"
2-1/2	4-1/8"	5-1/8"	6-3/4"	7-3/4"
3	4-5/8"	5-5/8"	6-3/4"	7-3/4"
4	5-5/8"	6-3/4"	7-3/4"	8-3/4"
5	6-3/4"	7-3/4"	8-3/4"	9-3/4"
6	7-3/4"	8-3/4"	9-3/4"	10-7/8"
8	9-7/8"	10-7/8"	11-7/8"	12-7/8"
10	12"	12-7/8"	14-1/4"	15-1/4"
12	14"	15-1/4"	16-1/4"	17-1/4"
14	15-1/8"	16-3/8"	17-3/8"	18-3/8"

Minimum Hanger Inside Diameter in Inches				
Copper Tubing	X 1/2	X 1	X 1-1/2	X 2
5/8"	2"	3"	3-1/2"	4-5/8"
7/8"	2"	3"	4-1/8"	5-1/8"
1-1/8"	2-1/4"	3"	4-1/8"	5-1/8"
1-3/8"	2-1/2"	3-5/8"	4-5/8"	5-5/8"
1-5/8"	3"	3-5/8"	5-1/8"	5-5/8"
2-1/8"	3-5/8"	4-1/8"	5-1/8"	6-3/4"
2-5/8"	4-1/8"	4-5/8"	5-5/8"	6-3/4"
3-1/8"	4-5/8"	5-1/8"	6-3/4"	7-3/4"
4-1/8"	5-5/8"	6-3/4"	7-3/4"	8-3/4"
6-1/8"	7-3/4"	8-3/4"	9-3/4"	10-7/8"

SNAPPITZ

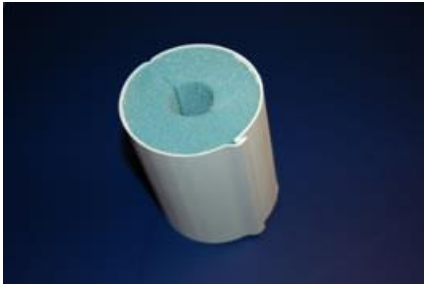

DESCRIPTION: Self locking PVC Jacket, insulation varies from Trymer Urethane or Insul-phen and are adhered inside a 360 degree PVC jacket.

WALL THICKNESS: 1"-4"

USES: Cold water, air, dual temperature, hot water, chilled water heating, clean room application

PHYSICAL PROPERTIES:

INSULATION: Polyisocyanurate (Trymer Foam Insulation)

JACKET: Special Purpose rigid PVC extrusion compound complies with the ASTM E 84-05 Standard Test Method for surface burning characteristics of materials.

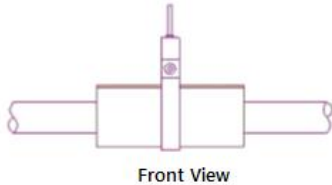

Front View

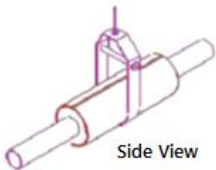

Side View



Side View

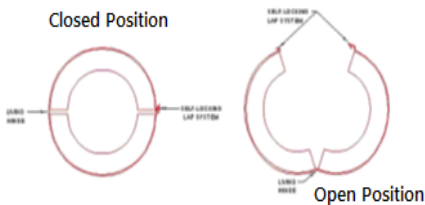

Closed Position

Open Position

TRYMER 2000 - URETHANE HAS THE FOLLOW CHARACTERISTICS:

- Compressive Strength = 24 p.s.i. average
- Flexural Strength = 44 p.s.i. average
- K Factor = .190 @ 75 Degrees F - aged 180 days
- Working Temperature Range = -297 Degrees F to 300+ Degrees F
- Trymer 2000 Insulation is used for 1/2" wall thickness insulation inserts

INSUL-PHEN - PHENOLIC FOAM HAS THE FOLLOWING CHARACTERISTICS:

- Compressive Strength = 3.75 54 p.s.i. average
- K Factor = .16 @ 250 Degrees F - aged 7 days
- Working Temperature Range = -290 Degrees F to = 250 Degrees F
- Insul-Phen density is used for over 1" wall thickness size

PRODUCT SPECIFICATION DRAWING
HOLDRITE® Stout Bracket® #SB1, #SB1S, #SB2 & #SB2S
Adjustable length support system

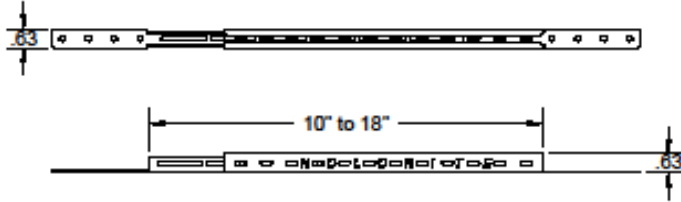

#SB1 / #SB1S

Beam Span Inches	Maximum Load (lbs.)	
	Center Pt.	Uniform Load
10	100	1150
14.5	164	300
18	104	131

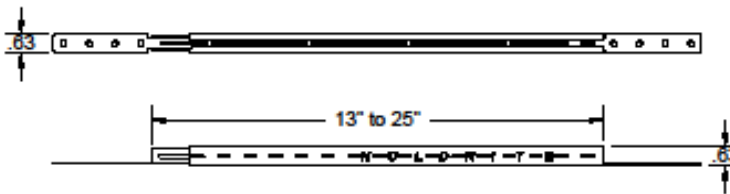

#SB2 / #SB2S

Beam Span Inches	Maximum Load (lbs.)	
	Center Pt.	Uniform Load
18	158	225
22.5	121	165
24	68	120

ALL DIMENSIONS IN INCHES

Slot pattern permits wide versatility in positioning. Mount fittings, clamps, etc. vertically or horizontally. Use with high-ear or wing-ear fittings. Supports shower head, tub spout, piping, etc. Holds HOLDRITE Pro Clamp™, Stout Clamp™ and others. Attaches between studs, joists, etc. Bendable end tabs allow recessed or surface mounting. Use anywhere high strength is required.

Product Information:

- Material: 16 gage CRS, galvanized per ASTM-A653, G90
- SB1S, SB2S series includes (4) #8 X 5/8" long self-drilling sheet metal screw with 1/4" X #2 phillips hex head
- UPC / IPC / IAPMO listed
- UL listing



Product Submittal	
Job Name:	
Date:	
Part Number:	Qty:
Architect / Owner:	
Contractor:	
Notes:	

THIS INFORMATION IS PROPRIETARY TO HOLDRITE AND IS SUBJECT TO CHANGE WITHOUT NOTICE. IT MAY NOT BE REPRODUCED IN PART OR WHOLE WITHOUT WRITTEN PERMISSION.



CONVERTING MAKESHIFT METHODS INTO ENGINEERED SOLUTIONS™
 800-321-0316 OR 760-744-6944 / FAX: 760-744-0507 / WWW.HOLDRITE.COM
 spec_SB_Series_RevP

Installation Instructions

HOLDRITE Stout Bracket® #SB3 & #SB4

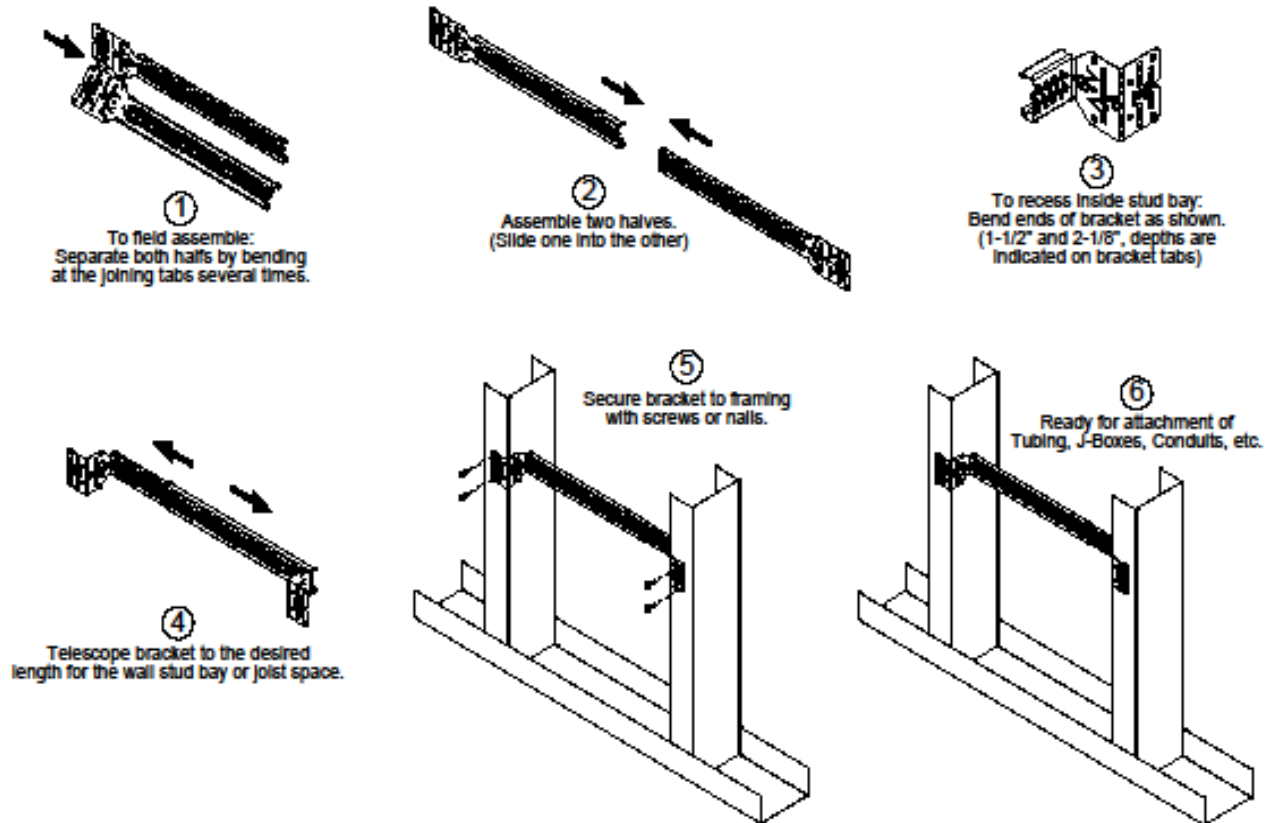

Model #	Description	Stud Bay Spacing	Ideal Recess Depths
SB3	Galvanized Steel Telescoping Bracket	10-1/4" to 16"	1-1/2" or 2-1/8"
SB4	Galvanized Steel Telescoping Bracket	14.5" to 24"	1-1/2" or 2-1/8"

WARNING:

- The buyer and/or installer is responsible for:
 - Application in conformance to local codes.
 - The integrity of structures to which the fasteners is attached, including their capability of safety accepting the load imposed, as evaluated by a qualified engineer. (Product load ratings are shown on the product's Specification Sheet at WWW.HOLDRITE.COM)
 - Using appropriate industry standard hardware such as sheet metal screws or dry wall screws. (Avoid using self-drilling screws tips, which remove excessive base materials)
- Failure to observe these Installation Instructions may cause product malfunction resulting in property damage or bodily injury.

SAFETY INSTRUCTIONS: All safety regulations required by the job site must be observed. Special attention should be given to the following instructions. While working on a job site:

- Wear safety glasses with side shields
- Wear gloves to avoid splinters and cuts.
- Be sure power tools are properly grounded.

HOLDRITE®

CONCRETE, MASONRY, STEEL, WOOD, BRICK, BLOCK, GYPSUM BOARD

800-321-0316 OR 760-744-6944 / FAX: 760-744-0507 / WWW.HOLDRITE.COM
77-000599-000, RevB (#SB3 & #SB4)

**PRODUCT SPECIFICATION DRAWING
HOLDRITE® STOUT CLAMP™ #250**

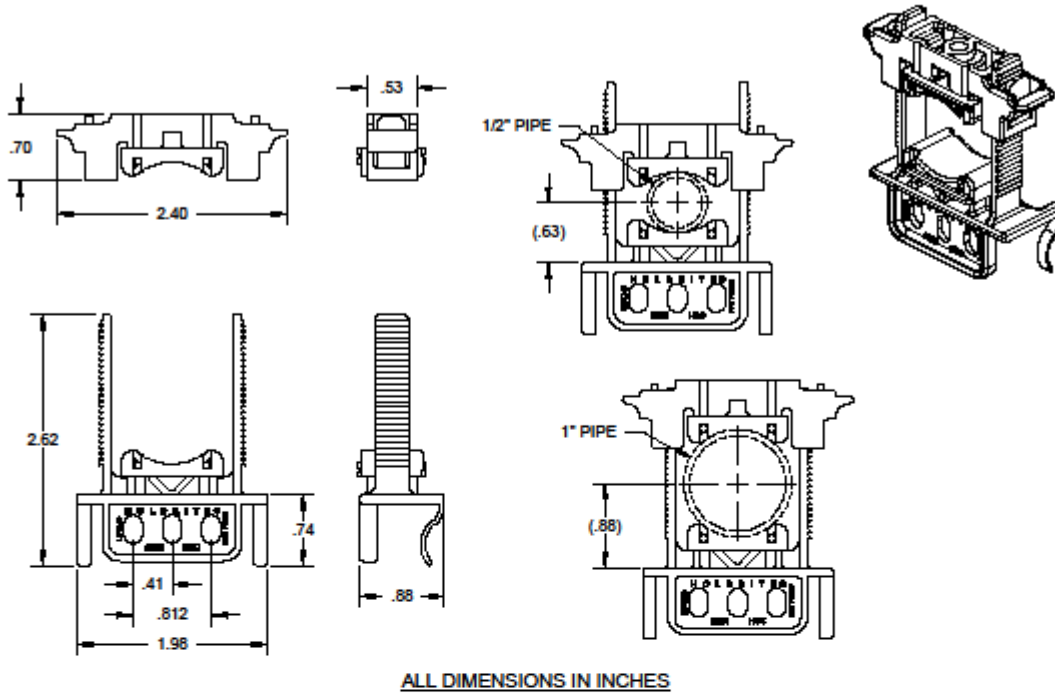

The HOLDRITE® Stout Clamp™ #250 is a strong, sound rated variable closure clamp compatible with Copper, PEX, CPVC pipe, conduit, etc. Supports up to 1" CTS tubing sizes. Frame work complies with UL94V-2 fire rating and UPC listed.

Product Information:

- **Material:**
Top & Bottom clamp: Nylon, medium blue, FR UL94V-2
Pads: TPR, natural (off-white), 50 shore A
- **Temperature range:** -10°F to 180°F
- **Load rating:** 25 lbs in suspended mode, 200 lbs maximum in top mount
- **UPC / IPC listed**
- **IAPMO listed, per standard PS42-96**
- **Patent Pending**



THIS INFORMATION IS PROPRIETARY TO HOLDRITE AND IS SUBJECT TO CHANGE WITHOUT NOTICE. IT MAY NOT BE REPRODUCED IN PART OR WHOLE WITHOUT WRITING FROM HOLDRITE.



CONVERT YOUR WANTS INTO SOLUTIONS INTO THE RIGHT SOLUTIONS™
800-321-0316 OR 760-744-6944 / FAX: 760-744-0507 / WWW.HOLDRITE.COM
spec_250_RevH

Product Submittal	
Job Name:	
Date:	
Part Number:	Qty:
Architect / Owner:	
Contractor:	
Notes:	

**PRODUCT SPECIFICATION DRAWING
 HOLDRITE® Stout Clamp™ #280**

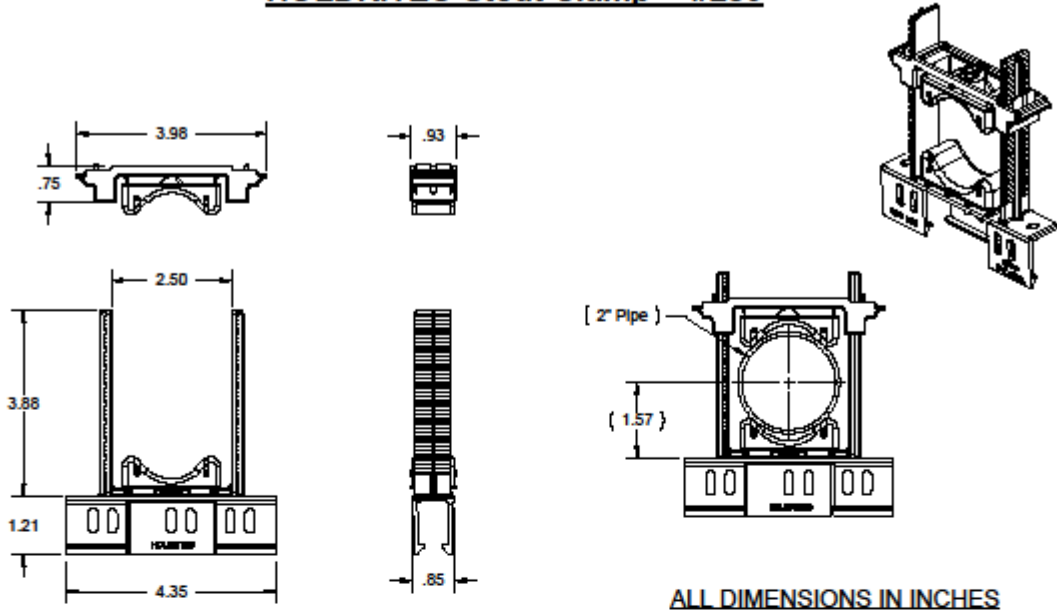

Sound rated variable closure clamp that may be installed to HOLDRITE® EZ-Strut™ or Stout Brackets™ with only one to three screws (for maximum load in suspension mode). Two acoustical inserts isolate the pipe from the supporting structure, reducing waterline noise and vibration, while allowing normal pipe expansion and contraction. Variable closure clamp supports 1" - 2" CTS and IPS pipe sizes. Supports Copper, PEX, CPVC tubing, conduit, etc. Frame complies with UL94V-2 flame rating.

Product Information:

- **Material:**
 Top & Bottom Clamp: Nylon, medium blue, FR UL94V-2
 Pads: TPR, natural (off-white), 50 shore A
- **Temperature range:** -10°F to +180°F
- **Load rating:** 75 lbs in suspended mode, 300 lbs maximum in top mount
- **Patent Pending**
- **UPC / IPC / IAPMO listed**



THIS INFORMATION IS PROPRIETARY TO HOLDRITE AND IS SUBJECT TO CHANGE WITHOUT NOTICE. IT MAY NOT BE REPRODUCED IN PART OR WHOLE WITHOUT WRITTEN AUTHORIZATION.



800-321-0316 OR 760-744-6944 / FAX: 760-744-0507 / WWW.HOLDRITE.COM
 spec_280_RevK

Product Submittal	
Job Name:	
Date:	
Part Number:	Qty:
Architect / Owner:	
Contractor:	
Notes:	

PRODUCT SPECIFICATION DRAWING
HOLDRITE® #101-18 & #101-26
Supports copper water supplies for
sinks, water closets and other fixtures

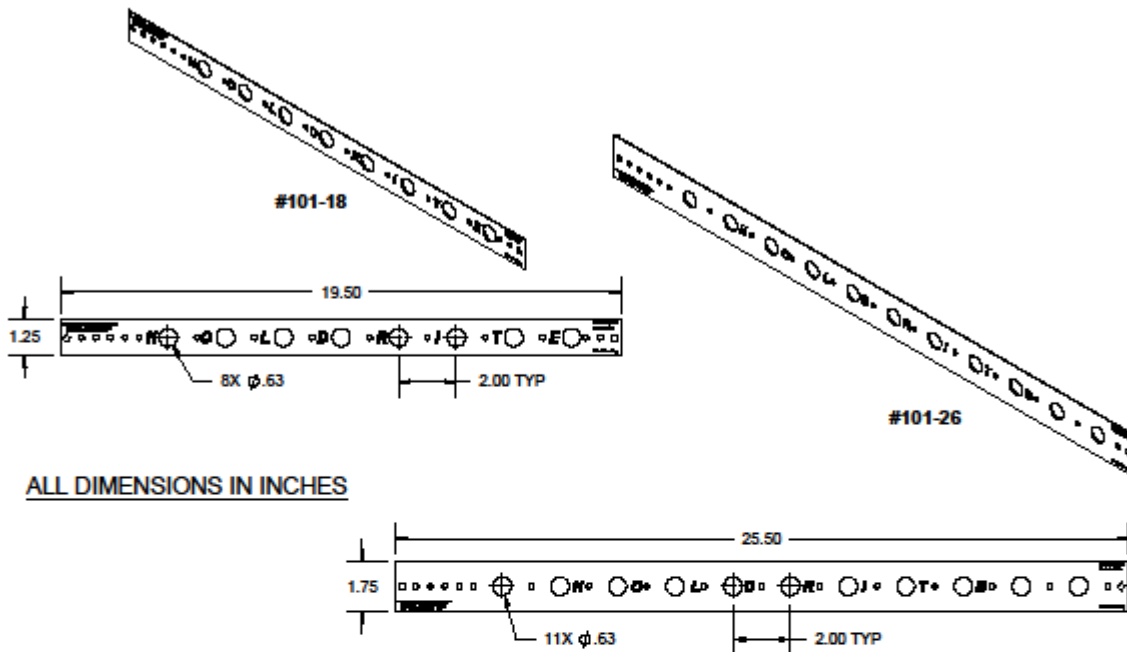

The HOLDRITE #101-18 & #101-26 is a Copper-Bonded™ steel brackets with 5/8" holes on 2" centers to support 1/2" copper tubing. The #101-18 & #101-26 position copper water supplies for sinks, water closets, and other fixtures. When soldering, heat the pipe, not the bracket.

Product Information:

- Material: 16 gage CRS, Copper-Bonded™
- Load rating: 25 pounds
- UPC / IPC / IAPMO listed



Product Submittal	
Job Name:	
Date:	
Part Number:	Qty:
Architect / Owner:	
Contractor:	
Notes:	

THIS DRAWING IS THE PROPERTY OF HOLDRITE. IT IS SUBJECT TO CHANGE WITHOUT NOTICE. IT MAY NOT BE REPRODUCED OR TRANSMITTED IN ANY FORM OR BY ANY MEANS WITHOUT PERMISSION.

HOLDRITE®

CONVERTING MAKESHIFT METHODS INTO ENGINEERED SOLUTIONS™

800-321-0316 OR 760-744-6944 / FAX: 760-744-0507 / WWW.HOLDRITE.COM

spec_101-18_-26_RevD

**PRODUCT SPECIFICATION DRAWING
 HOLDRITE® #102-18 & #102-26**

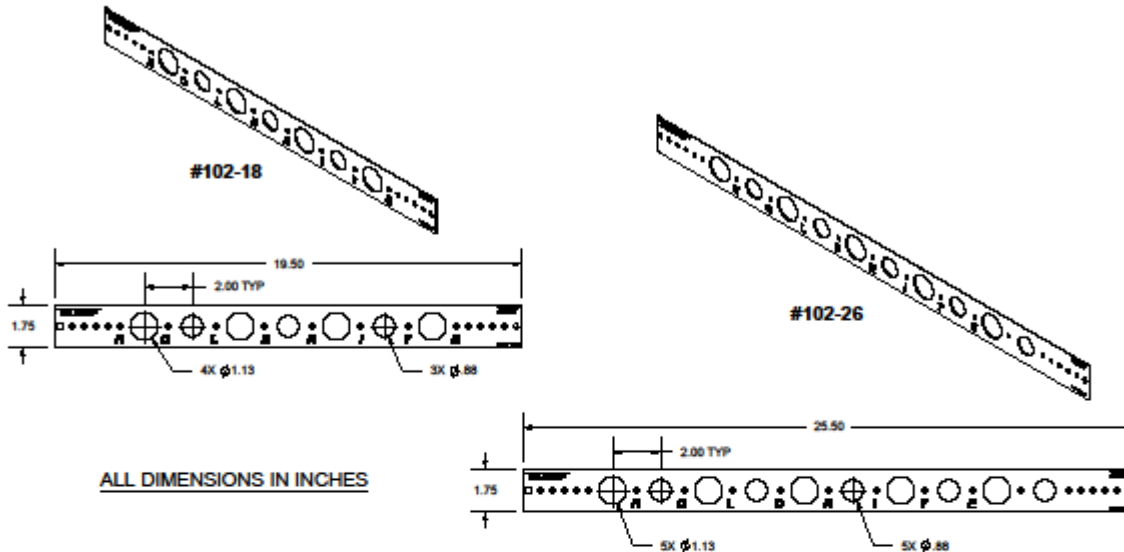

The HOLDRITE #102-18 and #102-26 are Copper-Bonded™ steel brackets with holes to support 3/4" and 1" copper tubing. Used to support stub-outs for hot water tanks, urinals and other fixtures. When soldering, heat the pipe, not the bracket.

Product Information:

- Material: 16 gage CRS, Copper-Bonded™
- Load rating: 25 pounds
- UPC / IPC / IAPMO listed

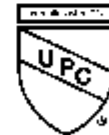

Product Submittal	
Job Name:	
Date:	
Part Number:	Qty:
Architect / Owner:	
Contractor:	
Notes:	

THIS DOCUMENT IS PROPRIETARY TO HOLDRITE AND IS SUBJECT TO CHANGE WITHOUT NOTICE. IT MAY NOT BE REPRODUCED IN PART OR WHOLE WITHOUT WRITTEN AUTHORIZATION.



CONVERTING MARKS INTO ENGINEERED SOLUTIONS™
 800-321-0316 OR 760-744-6944 / FAX: 760-744-0507 / WWW.HOLDRITE.COM
 spec_102-18_-26_RevD

**PRODUCT SPECIFICATION DRAWING
HOLDRITE® #107-18 BRACKET**

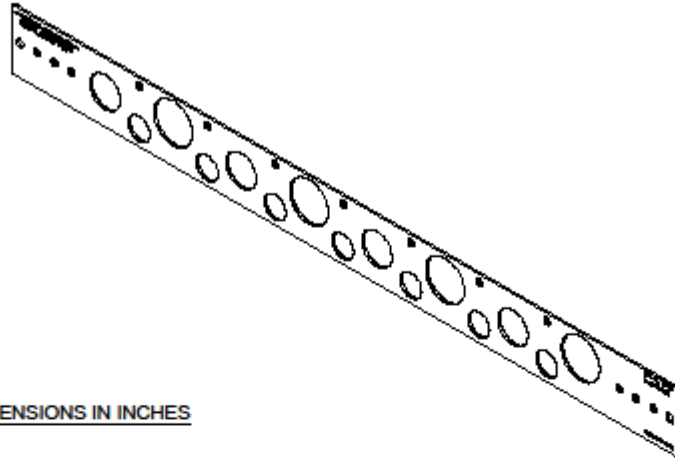

ALL DIMENSIONS IN INCHES

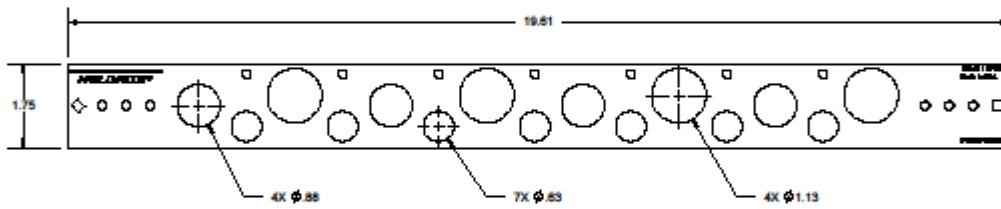

The HOLDRITE #107-18 is a Copper-Bonded™ steel bracket with holes on 2" centers to position 1/2" copper tubing and holes on 4" centers to position 3/4" and 1" copper tubing.

Product Information:

- Material: 16 gage CRS, Copper-Bonded™
- Load rating: 25 pounds
- UPC / IPC / IAPMO listed



Product Submittal	
Job Name:	
Date:	City:
Part Number:	
Architect / Owner:	
Contractor:	
Notes:	

THIS INFORMATION IS PROPRIETARY TO HOLDRITE AND IS SUBJECT TO CHANGE WITHOUT NOTICE. IT MAY NOT BE REPRODUCED OR TRANSMITTED IN ANY FORM OR BY ANY MEANS WITHOUT PERMISSION.



CONVERTING MAKESHIFT METHODS INTO ENGINEERED SOLUTIONS™
800-321-0316 OR 760-744-6944 / FAX: 760-744-0507 / WWW.HOLDRITE.COM
spec_107-18_RevD

ANCHORS

Wedge Anchor (Quick Bolt)

Finish: Zinc

Material: Low Carbon Steel

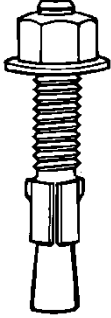

FUNCTION: Wedge Anchor is a non-bottom bearing, wedge style expansion anchor for use in solid concrete or grout filled masonry. A one-piece clip ensures uniform holding capacity that increases as tension is applied.

APPROVALS: ICBO ER-3631; SBCCI 9706; City of L.A. RR24682; Dade County 01-0820.06; Factory Mutual 1M6AO.AH; Underwriters Laboratories File Ex3605; multiple DOT listings. Meets requirements of Federal Specifications A-A-1923A, Type 4.

Note: The Load Values below are for all lengths of a given diameter capable of reaching the embedment specified

Diameter & Length	Thread Length	Max. Material Thickness	Req. Torque (ft. lbs.)	Embedment	Tension 2000 PSI	Shear	Tension 4000 PSI	Shear
1/4 x 1-1/2"	-	-	8-10	1-1/8"	1,173	1,472	1,015	1,472
1/4 x 1-3/4"	7/8"	3/8"	8-10	1-1/8"	1,173	1,472	1,015	1,472
1/4 x 2-1/4"	1-3/8"	7/8"	8-10	2-1/4"	2,573	1,472	1,015	1,472
1/4 x 3-1/4"	2-1/4"	1-7/8"	8-10	2-1/4"	2,573	1,472	2,711	1,472
3/8 x 2-1/4"	1-3/16"	1/4"	15-30	1-5/8"	2,289	3,151	2,367	3,151
3/8 x 2-3/4"	1-5/8"	3/4"	15-30	1-5/8"	2,289	3,151	2,367	3,151
3/8 x 3"	1-7/8"	1"	15-30	3-3/8"	3,556	3,151	5,203	3,151
3/8 x 3-3/4"	2-5/8"	1-3/4"	15-30	3-3/8"	3,556	3,151	5,203	3,151
3/8 x 5"	4"	3"	15-30	3-3/8"	3,556	3,151	5,203	3,151
1/2 x 2-3/4"	1-1/2"	1/8"	25-50	2-1/4"	4,120	6,828	5,068	6,828
1/2 x 3-3/4"	2-1/2"	1"	25-50	2-1/4"	4,120	6,628	5,068	6,628
1/2 x 4-1/4"	3"	1-1/2"	25-50	4-1/2"	4,608	6,828	5,772	6,828
1/2 x 5-1/2"	4"	2-3/4"	25-50	4-1/2"	4,608	6,828	5,772	6,828
1/2 x 7"	4"	4-1/4"	25-50	4-1/2"	4,608	6,828	5,772	6,828
5/8 x 3-1/2"	1-5/8"	1/8"	40-75	2-3/4"	5,486	9,659	5,556	9,659
5/8 x 4-1/2"	2-5/8"	1-1/8"	40-75	2-3/4"	5,486	9,659	5,556	9,659
5/8 x 5"	3-1/4"	1-5/8"	40-75	2-3/4"	5,486	9,659	5,556	9,659
5/8 x 6"	4-1/8"	2-5/8"	40-75	5-5/8"	6,957	9,659	9,294	9,659
5/8 x 7"	4"	3-5/8"	40-75	5-5/8"	6,957	9,659	9,294	9,659
5/8 x 8-1/2"	4"	5-1/8"	40-75	5-5/8"	6,957	9,659	9,294	9,659
5/8 x 10"	4"	6-5/8"	40-75	5-5/8"	6,957	9,659	9,294	9,659
3/4 x 4-1/4"	2-3/8"	1/8"	100-200	3-3/8"	9,267	15,126	11,975	15,126
3/4 x 4-3/4"	2-7/8"	5/8"	100-200	3-3/8"	9,267	15,126	11,975	15,126
3/4 x 5-1/2"	3-5/8"	1-3/8"	100-200	3-3/8"	9,267	15,126	11,975	15,126
3/4 x 6-1/4"	4-1/4"	2-1/8"	100-200	3-3/8"	9,267	15,126	11,975	15,126
3/4 x 7"	4"	2-7/8"	100-200	6-3/4"	13,278	15,126	16,201	15,126
3/4 x 8-1/2"	4"	4-3/8"	100-200	6-3/4"	13,278	15,126	16,201	15,126
3/4 x 10"	4"	5-7/8"	100-200	6-3/4"	13,278	15,126	16,201	15,126
3/4 x 12"	4"	7-7/8"	100-200	6-3/4"	13,278	15,126	16,201	15,126
7/8 x 6"	3-1/2"	1-1/8"	125-225	4"	9,746	21,574	13,902	21,574
7/8 x 8"	4"	3-1/8"	125-225	8"	14,378	21,574	20,288	21,574
7/8 x 10"	4"	5-1/8"	125-225	8"	14,378	21,574	20,288	21,574
1 x 6"	3-1/2"	1/2"	150-250	4-1/2"	10,226	28,023	15,829	28,023
1 x 9"	4"	3-1/2"	150-250	9"	15,479	28,023	24,375	28,023
1 x 12"	4"	6-1/2"	150-250	9"	15,479	28,023	24,375	28,023
1-1/4 x 9"	3-1/4"	1-1/4"	200-350	6-1/2"	14,720	33,000	23,090	36,600
1-1/4 x 12"	3-1/4"	4-1/4"	200-350	6-1/2"	14,720	33,000	23,090	36,600

Drop - In Anchor

Finish: Zinc

Material: Low Carbon Steel

Manufacturer: Wej-IT



FUNCTION: Drop-In Anchors are internally threaded deformation controlled expansion anchors with a preassembled expander plug, suitable for flush mount applications in solid base materials. The anchor is set by driving the expansion plug towards the bottom of the anchor using the setting tool.

The **3/8" Short Drop-In Anchor** is an internally threaded drop-in anchor for use in solid and hollow concrete. The short length permits shallow embedment, therefore avoiding drilling into rebar or prestressing strands. The wide surface flange allow the short drop-in to be installed in deep or bottomless holes.

Installation Sequence
(Short Drop-In similar)

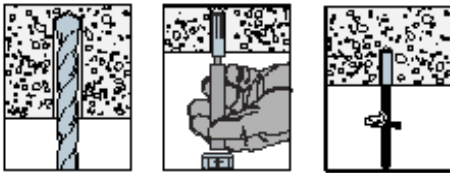

The anchor is fully expanded when the shoulder of the setting tool makes contact with the top of the anchor.

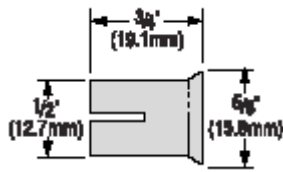

Short Drop-In Dimensions



Setting Tool Sizes
1/4
3/8
1/2
5/8
3/4

APPROVALS: ICBO ER-3631; City of L.A. RR24682; Dade County, FL 01-0820.06; Factory Mutual 1M6AO.AH; Underwriters Laboratories File Ex3605; multiple DOT listings. Meets requirements of Federal Specifications A-A-55614, Type I.

Anchor Component	Component Material		
	Zinc Plated Carbon Steel	Type 303 Stainless Steel	Type 316 Stainless Steel
Anchor Body	Meets minimum 70,000 psi tensile	AISI 303. Meets chemical requirements of ASTM A-582	Type 316
Expander Plug	Meets minimum 50,000 psi tensile	AISI 303	Type 316
Thread	UNC 2B/Coil Thread	UNC 2B	Type 316

Size (in)	Carbon Steel	303 Stainless Steel	316 Stainless Steel	Drill Bit Diameter (in)	Bolt Threads (per in)	Body Length (in)
1/4	x	x	x	3/8	20	1
3/8	x	x	x	1/2	16	1-1/2
3/8 Short	x	-	-	1/2	16	3/4
1/2	x	x	x	5/8	13	2
5/8	x	x	-	7/8	11	2-1/2
3/4	x	x	-	1	10	3-1/8
1/2	x	-	-	5/8	6	2
3/4	x	-	-	1	5	3-1/8

Tension Loads for Drop-In Anchors in Normal-Weight Concrete

Size (in.)	Drill Bit Dia. (In.)	Embed. Depth (In.)	Critical Edge Dist. (In.)	Critical Spacing (In.)	Tension Load						
					f'c >=2000 psi (13.8 Mpa) Concrete			f'c >=3000 psi (20.7 Mpa) Concrete	f'c >=4000 psi (27.6 Mpa) Concrete		
					Ultimate Lbs.	Std. Dev. Lbs.	Allow Lbs.	Allow Lbs.	Ultimate Lbs.	Std. Dev. Lbs.	Allow Lbs.
1/4	3/8	1	3-1/2	4	1400	201	350	405	1840	451	460
3/8	1/2	1-1/2	5-1/4	6	2400	251	600	795	3960	367	990
1/2	5/8	2	7	8	3320	372	830	1178	6100	422	1525
5/8	7/8	2-1/2	8-3/4	10	5040	689	1260	1715	8680	971	2170
3/4	1	3	10-1/2	12	8160	961	2040	2365	10760	1696	2690

1. The allowable loads listed are based on a safety factor of 4.0.
2. Allowable loads may be increased by 33-1/3% for short term loading due to wind or seismic force.
3. Allowable loads may be linearly interpolated between concrete strengths listed
4. The minimum concrete thickness is 1-1/2 times the embedment depth.

Size (in.)	Drill Bit Dia. (In.)	Embed. Depth (In.)	Critical Edge Dist. (In.)	Critical Spacing (In.)	Shear Load					
					f'c >=2000 psi (13.8 Mpa) Concrete			f'c >=3000 psi (20.7 Mpa) Concrete	f'c >=4000 psi (27.6 Mpa) Concrete	
					Ultimate Lbs.	Std. Dev. Lbs.	Allow Lbs.	Allow Lbs.	Allow Lbs.	
1/4	3/8	1	3-1/2	4	1960	178	490	490	490	
3/8	1/2	1-1/2	5-1/4	6	3240	351	810	925	1040	
1/2	5/8	2	7	8	7000	562	1750	1750	1750	
5/8	7/8	2-1/2	8-3/4	10	11080	923	2770	2770	2770	
3/4	1	3	10-1/2	12	13800	1781	3450	3725	4000	

Size (In.)	Drill Bit Dia. (In.)	Embed. Depth (In.)	Tension Critical Edge Dist. (In.)	Shear Critical Spacing (In.)	Drill Bit Dia. (In.)	Tension Load			Shear Load		
						Ultimate Lbs.	Std. Dev. Lbs.	Allow Lbs.	Ultimate Lbs.	Std. Dev. Lbs.	Allow Lbs.
Normal-Weight Concrete, f'c >-2000 psi (13.8 Mpa)											
3/8	1/2	3/4	4-1/2	5-1/4	3	1948	44	485	2274	374	570
Normal-Weight Concrete, f'c >-4000 psi (27.6 Mpa)											
3/8	1/2	3/4	4-1/2	5-1/4	3	2701	344	675	3308	210	825

1. The allowable loads listed are based on a safety factor of 4.0.
2. Allowable loads may not be increased for short term loading due to wind or seismic force.

Size (in.)	Drill Bit Dia. (In.)	Embed. Depth (In.)	Tension Critical Edge Dist. (In.)	Shear Critical Spacing (In.)	Critical Spacing (In)	Tension Load			Shear Load		
						f'c >=3000 psi (13.8 Mpa) Concrete			f'c >=3000 psi (27.6 Mpa) Concrete		
						Ultimate Lbs.	Std. Dev. Lbs.	Allow Lbs.	Ultimate Lbs.	Std. Dev. Lbs.	Allow Lbs.
3/8	1/2	1-1/2	6	7	8	3000	367	750	2400	187	600
1/2	5/8	2	8	9-3/8	10-5/8	3580	861	895	5600	200	1400

BLUE BANGER HANGER® Cast-In-Place, Internally-Threaded Inserts

Blue Banger Hanger® internally-threaded inserts are cast into the underside of the concrete deck after being fastened to the top of wood forms or metal deck. Once the concrete has cured, the anchor provides an attachment point for threaded rod used to hang electrical, mechanical and plumbing utilities. The Blue Banger Hanger insert is the only pre-pour insert to offer the patented multi-thread design which allows one size insert to handle multiple diameters of threaded rod.

FEATURES:

- Quick and easy installation saves time and money- no assembly required.
- Patented multi-thread design allows each hanger to accept multiple diameters of threaded rod. Three sizes of hangers can handle all applications, reducing contractor and distributor inventories.
- Multi-thread design allows threaded rod size to be changed after the anchor is in the concrete.
- Machined steel insert with large flanged head provides high tension and shear loads for overhead attachments.
- Positive attachment to form keeps the hanger vertical and in the correct position.
- Internal threads eliminate the cost of rod couplers.
- The head is stamped with the Simpson Strong-Tie® "S" sign for easy identification before the concrete pour.

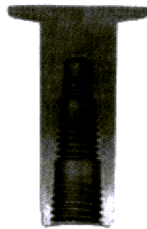

Patented multi-thread design allows one product to handle up to three rod diameters.

MATERIAL: Carbon steel

FINISH: Yellow-zinc dichromate

CODES: Factory Mutual 3024378 (except roof deck insert); Underwriters Laboratories File EX3605 (except roof deck insert); See pipe size limit tables.

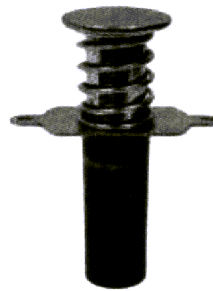

Blue Banger Hanger® Metal Deck Insert (BBMD)
U.S. Patent 6,240,697B1

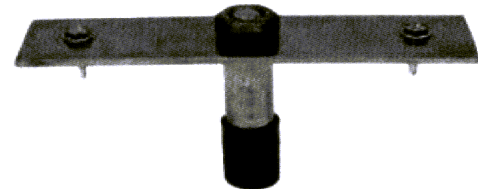

Blue Banger Hanger® Roof Deck Insert (BBRD)
U.S. Patent 6,240,697B1

Blue Banger Hanger Product Data

Hanger Type	For Rod Diameter (in.)	Deck Hole Diameter (in.)	Model No.	Carton Qty.
Metal Deck Insert	1/4, 3/8, 1/2	13/16-7/8	BBMD2550	100
	3/8, 1/2, 5/8	1 1/8-1 3/16	BBMD3762	50
	5/8, 3/4	1 3/16-1 1/4	BBMD6275	50
Roof Deck Insert	1/4, 3/8, 1/2	7/8	BBRD2550	50
Wood Form Insert	1/4, 3/8, 1/2	N/A	BBWF2550	200
	3/8, 1/2, 5/8		BBWF3762	150
	5/8, 3/4		BBWF6275	150

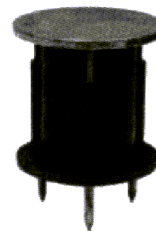

Blue Banger Hanger® Wood Form Insert (BBWF)
U.S. Patent 6,240,697B1

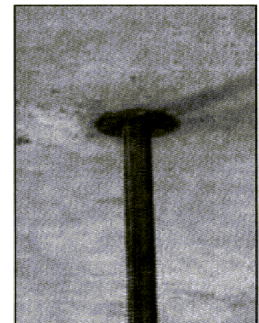

DRILL EXTENSIONS:

Drill extensions allow holes to be drilled for Blue Banger Hanger® insert installation without having to repeatedly bend down. An ideal way to save installation time and reduce worker fatigue. Available for use with hole saws and step drills.

Drill Extensions

Description	Model No.
2' extension for use with hole saws	BBDEHS
2' extension for use with 3/8" shank step drills	BBDE37
2' extension for use with 1/2" shank step drills	BBDE50

Hole saws and step drills not included.

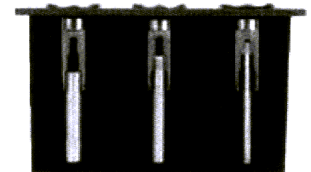
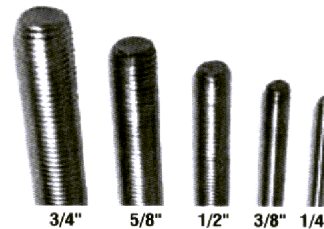

Multiple rod diameters are easily accommodated with the Blue Banger Hanger®.



Step Drill Bit Extension (bit not included)



Hole Saw Bit Extension (bit not included)

BLUE BANGER HANGER® *Cast-In-Place Internally Threaded Inserts*

SIMPSON

Strong-Tie
ANCHOR SYSTEMS

BLUE BANGER HANGER® - METAL DECK INSERT

FEATURES:

- 3' plastic sleeve keeps internal threads clean.
- Extended length of the sleeve allows easy location of the insert even with fireproofing on the underside of the deck. Also provides guidance to align threaded rod with the internal threads.
- Installed height of 2" allows the insert to be used on top of, or between, deck ribs.
- Compression spring keeps the insert perpendicular to the deck, even if it is bumped or stepped on after installation.
- Multi-thread design: Each insert accepts 2–3 rod diameters.

INSTALLATION:

- Drill a hole in the metal deck using the appropriate diameter bit as referenced in the table.
- Insert the hanger into the hole and strike the top so that the plastic sleeve is forced through the hole and expands against the bottom side of the deck. The anchor can also be installed by stepping on it.

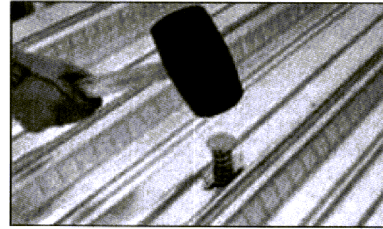

Metal Deck Insert Installation Sequence

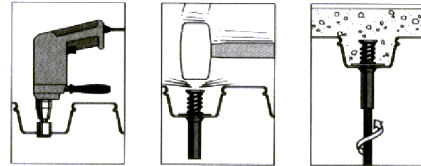

BLUE BANGER HANGER® - METAL ROOF DECK INSERT

FEATURES:

- Low profile design doesn't interfere with roofing material.
- Plastic sleeve allows for easy identification and keeps internal threads clean.
- Positive attachment to the roof deck prevents spinning and keeps the hanger in position.
- Pre-staked screws allow quick installation.
- Multi-thread design: The insert accepts 3 rod diameters.

INSTALLATION:

- Drill a hole in the metal deck using the appropriate diameter bit as referenced in the table.
- Insert the hanger into the hole and fasten to the deck with the two pre-staked, self-drilling sheet metal screws provided.

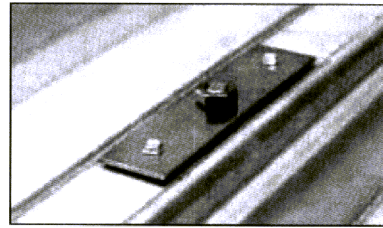

Metal Roof Deck Insert Installation Sequence

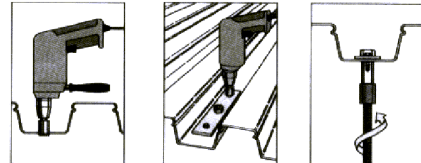

BLUE BANGER HANGER® - WOOD FORM INSERT

FEATURES:

- Blue plastic ring acts as an insert locator when forms are removed.
- Plastic ring creates a countersunk recess to keep internal threads clean from concrete residue.
- Nails snap off with the swipe of a hammer after the forms are removed.
- Multi-thread design: Each insert accepts 2–3 rod diameters.

INSTALLATION:

- Strike the top of the hanger and drive the 3 mounting nails into the forming material until the bottom of the hanger is flush with the plywood. The hanger should be sitting 90° perpendicular to the forming material.
- Once concrete is hardened, and forms are stripped, strike the mounting nails to break them off.

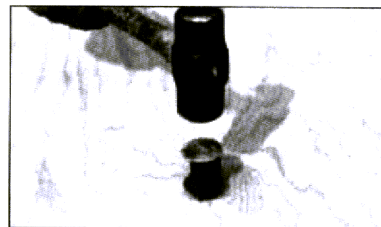

Wood Form Insert Installation Sequence

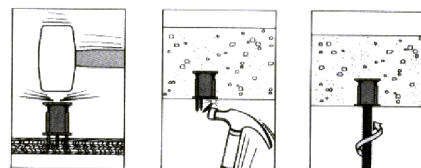

BLUE BANGER HANGER® Cast-In-Place Internally Threaded Inserts

SIMPSON

Strong-Tie
ANCHOR SYSTEMS

Wood Form Insert: Tension Loads in Normal-Weight Concrete



Model No.	Threaded Rod Dia. in.	Embed. Depth in. (mm)	Min. Edge Dist. in. (mm)	Min. Spacing in. (mm)	Tension Load Based on Concrete Strength		Tension Load Based on Rod Strength	
					f'c ≥ 3000 psi (20.7 MPa) Concrete		A307 (SAE 1018)	
					Ultimate lbs. (kN)	Allowable lbs. (kN)	Allowable lbs. (kN)	Allowable lbs. (kN)
BBWF2550	1/4	2 (51)	7 (178)	8 (203)	6,820 (30.3)	1,705 (7.6)	940 (4.2)	2,105 (9.4)
	3/8						3,750 (16.7)	
	1/2						3,750 (16.7)	
BBWF3762	3/8	2 (51)	7 (178)	8 (203)	7,360 (32.7)	1,840 (8.2)	2,105 (9.4)	3,750 (16.7)
	1/2						5,875 (26.1)	
	5/8						5,875 (26.1)	
BBWF6275	5/8	2 (51)	7 (178)	8 (203)	7,420 (33.0)	1,855 (8.3)	5,875 (26.1)	8,460 (37.6)
	3/4						8,460 (37.6)	

Roof Deck Insert: Tension Loads in Metal Deck

Model No.	Drill Bit Dia. in.	Threaded Rod Dia. in.	Allowable Tension Load lbs. (kN)	
			1 1/2" Deck	3" Deck
			BBRD2550	13/16-7/8

1. The allowable loads are based on a factor of safety of 4.0.
2. Allowable loads may not be increased for short-term loading due to wind or seismic forces.
3. Acceptability of deck deflection due to imposed loads must be investigated separately.
4. Threaded-rod strength must be investigated separately.
5. Anchors may be installed in the top or bottom flute of the metal deck.
6. Deck shall be 20-gauge minimum.

See Notes Below

Wood Form Insert: Shear Loads in Normal-Weight Concrete



Model No.	Threaded Rod Dia. in.	Embed. Depth in. (mm)	Min. Edge Dist. in. (mm)	Min. Spacing in. (mm)	Shear Load Based on Concrete Strength		Shear Load Based on Rod Strength	
					f'c ≥ 3000 psi (20.7 MPa) Concrete		A307 (SAE 1018)	
					Ultimate lbs. (kN)	Allowable lbs. (kN)	Allowable lbs. (kN)	Allowable lbs. (kN)
BBWF2550	1/2	2 (51)	7 (178)	8 (203)	8,750 (38.9)	2,185 (9.7)	1,930 (8.6)	
BBWF3762	5/8	2 (51)	7 (178)	8 (203)	10,700 (47.6)	2,675 (11.9)	3,025 (13.4)	
BBWF6275	3/4	2 (51)	7 (178)	8 (203)	10,460 (46.5)	2,615 (11.6)	4,360 (19.4)	

See Notes Below

Typical Roof Deck Insert Installation in Metal Deck

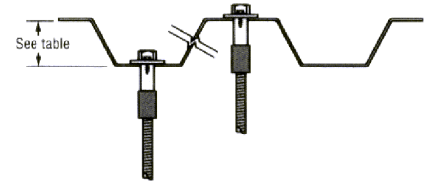

Wood Form Insert: Tension Loads in Sand-Lightweight Concrete

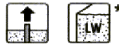

Model No.	Threaded Rod Dia. in.	Embed. Depth in. (mm)	Min. Edge Dist. in. (mm)	Min. Spacing in. (mm)	Tension Load Based on Concrete Strength		Tension Load Based on Rod Strength	
					f'c ≥ 3000 psi (20.7 MPa) Concrete		A307 (SAE 1018)	
					Ultimate lbs. (kN)	Allowable lbs. (kN)	Allowable lbs. (kN)	Allowable lbs. (kN)
BBWF2550	1/4	2 (51)	7 (178)	8 (203)	4,280 (19.0)	1,070 (4.8)	940 (4.2)	2,105 (9.4)
	3/8						3,750 (16.7)	
	1/2						3,750 (16.7)	
BBWF6275	5/8	2 (51)	7 (178)	8 (203)	4,400 (19.6)	1,100 (4.9)	5,875 (26.1)	8,460 (37.6)
	3/4						8,460 (37.6)	

*See page 10 for an explanation of the load table icons

See notes below.

Wood Form Insert: Shear Loads in Sand-Lightweight Concrete



Model No.	Threaded Rod Dia. in.	Embed. Depth in. (mm)	Min. Edge Dist. in. (mm)	Min. Spacing in. (mm)	Shear Load Based on Concrete Strength		Shear Load Based on Rod Strength	
					f'c ≥ 3000 psi (20.7 MPa) Concrete		A307 (SAE 1018)	
					Ultimate lbs. (kN)	Allowable lbs. (kN)	Allowable lbs. (kN)	Allowable lbs. (kN)
BBWF2550	1/2	2 (51)	7 (178)	8 (203)	8,600 (38.2)	2,150 (9.6)	1,930 (8.6)	
BBWF6275	3/4	2 (51)	7 (178)	8 (203)	9,260 (41.2)	2,315 (10.3)	4,360 (19.4)	

1. Allowable load must be the lesser of the concrete or steel strength.
2. The allowable loads based on concrete strength are based on a factor of safety of 4.0.
3. Allowable loads may not be increased for short-term loading due to wind or seismic forces.
4. Mechanical and plumbing design codes may prescribe lower allowable loads. Verify with local codes.
5. Minimum concrete slab thickness = 2x embedment depth.

BLUE BANGER HANGER® Cast-In-Place Internally Threaded Inserts

Metal Deck Insert: Tension Loads in Normal-Weight or Sand-Lightweight Concrete over Metal Deck



Model No.	Drill Bit Dia. in.	Threaded Rod Dia. in.	Embed. Depth in. (mm)	Min. Edge Dist. in. (mm)	Min. Spacing in. (mm)	Tension Load Based on Concrete Strength (Install in High Flute)		Tension Load Based on Concrete Strength (Install in Low Flute)		Tension Load Based on Rod Strength
						f'c ≥ 3000 psi (20.7 MPa) Concrete		f'c ≥ 3000 psi (20.7 MPa) Concrete		A307 (SAE 1018)
						Ultimate lbs. (kN)	Allowable lbs. (kN)	Ultimate lbs. (kN)	Allowable lbs. (kN)	Allowable lbs. (kN)
BBMD2550	1 ³ / ₁₆ -7/8	1/4	2 (51)	7 1/2 (191)	8 (203)	9,320 (41.5)	2,330 (10.4)	3,210 (14.3)	800 (3.6)	940 (4.2)
		3/8								2,105 (9.4)
		1/2								3,750 (16.7)
BBMD3762	1 1/8-1 3/8	3/8	2 (51)	7 1/2 (191)	8 (203)	10,540 (46.9)	2,635 (11.7)	3,440 (15.3)	860 (3.8)	2,105 (9.4)
		1/2								3,750 (16.7)
		5/8								5,875 (26.1)
BBMD6275	1 3/16-1 3/8	5/8	2 (51)	7 1/2 (191)	8 (203)	12,360 (55.0)	3,090 (13.7)	3,445 (15.3)	860 (3.8)	5,875 (26.1)
		3/4								8,460 (37.6)

* See page 10 for an explanation of the load table icons

See notes below.

Metal Deck Insert: Shear Loads in Normal-Weight or Sand-Lightweight Concrete over Metal Deck



Model No.	Drill Bit Dia. in.	Threaded Rod Dia. in.	Embed. Depth in. (mm)	Min. Edge Dist. in. (mm)	Min. Spacing in. (mm)	Shear Load Based on Concrete Strength (Install in High Flute)		Shear Load Based on Concrete Strength (Install in Low Flute)		Shear Load Based on Rod Strength
						f'c ≥ 3000 psi (20.7 MPa) Concrete		f'c ≥ 3000 psi (20.7 MPa) Concrete		A307 (SAE 1018)
						Ultimate lbs. (kN)	Allowable lbs. (kN)	Ultimate lbs. (kN)	Allowable lbs. (kN)	Allowable lbs. (kN)
BBMD2550	1 ³ / ₁₆ -7/8	1/2	2 (51)	7 1/2 (191)	8 (203)	9,720 (43.2)	2,430 (10.8)	2,790 (12.4)	700 (3.1)	1,930 (8.6)
BBMD3762	1 1/8-1 3/8	5/8	2 (51)	7 1/2 (191)	8 (203)	9,400 (41.8)	2,350 (10.4)	3,360 (14.9)	840 (3.7)	3,025 (13.4)
BBMD6275	1 3/16-1 3/8	3/4	2 (51)	7 1/2 (191)	8 (203)	9,720 (43.2)	2,430 (10.8)	3,360 (14.9)	840 (3.7)	4,360 (19.4)

* See page 10 for an explanation of the load table icons

1. Allowable load must be the lesser of the concrete or rod strength.
2. The allowable loads based on concrete strength are based on a factor of safety of 4.0.
3. Allowable loads may not be increased for short-term loading due to wind or seismic forces.
4. Anchors may be installed off-center in the flute, up to 1" from the edge of flute.
5. Shear loads shall be applied flush with metal deck surface.
6. Deck shall be 20-gauge minimum.
7. Mechanical and plumbing design codes may prescribe lower allowable loads. Verify with local codes.

Typical Metal Deck Installation

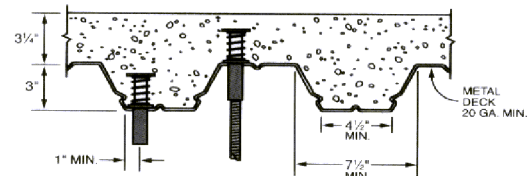

Wood Form Insert: Factory Mutual and Underwriters Laboratories Pipe Size Limits

Model No.	Rod Dia. in.	FM Max. Nominal Pipe Size in.	UL Max. Nominal Pipe Size in.
BBWF2550	1/4	N/L	4
	3/8	4	4
	1/2	8	8
BBWF3762	3/8	4	4
	1/2	8	8
	5/8	N/L	8
BBWF6275	5/8	N/L	N/L
	3/4		

1. N/L = Not listed for this pipe size.

Metal Deck Insert: Factory Mutual and Underwriters Laboratories Pipe Size Limits

Model No.	Rod Dia. in.	FM Max. Nominal Pipe Size		UL Max. Nominal Pipe Size	
		Install in High Flute in.	Install in Low Flute in.	Install in High Flute in.	Install in Low Flute in.
BBMD2550	1/4	N/L	N/L	4	4
	3/8	4	4	4	4
	1/2	8	N/L	8	4
	3/8	4	4	4	4
BBMD3762	1/2	8	N/L	8	4
	5/8	N/L	N/L	8	4
	3/4	12	N/L	12	N/L
BBMD6275	3/4	12	N/L	12	N/L

1. N/L = Not listed for this pipe size.

Errata

Blue Banger Hanger® Cast-in-Place, Internally Threaded Inserts

From Page 159 of C-SAS-2009 Anchoring and Fastening Systems for Concrete and Masonry catalog.
New code information has been added to the Blue Banger Hanger

Blue Banger Hanger® internally-threaded inserts are cast into the underside of the concrete deck after being fastened to the top of wood forms or metal deck. Once the concrete has cured, the anchor provides an attachment point for threaded rod used to hang electrical, mechanical and plumbing utilities. The Blue Banger Hanger insert is the only pre-pour insert to offer the patented multi-thread design which allows one size insert to handle multiple diameters of threaded rod.

FEATURES:

- Quick and easy installation saves time and money- no assembly required.
- Patented multi-thread design allows each hanger to accept multiple diameters of threaded rod. Three sizes of hangers can handle all applications, reducing contractor and distributor inventories.
- Multi-thread design allows threaded rod size to be changed after the anchor is in the concrete.
- Machined steel insert with large flanged head provides high tension and shear loads for overhead attachments.
- Positive attachment to form keeps the hanger vertical and in the correct position.
- Internal threads eliminate the cost of rod couplers.
- The head is stamped with the Simpson Strong-Tie® "S" sign for easy identification before the concrete pour.

MATERIAL: Carbon steel

FINISH: Yellow-zinc dichromate

CODES: Factory Mutual 3024378 (except roof deck insert); Underwriters Laboratories File EX3605 (except roof deck insert). Metal deck insert (BBMD) in compliance with UL Standard 2043, 2nd edition, "Fire test for heat and visible smoke release for discrete products and their accessories installed in air handling spaces."

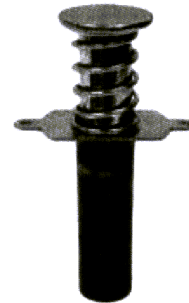

Blue Banger Hanger®
Metal Deck Insert (BBMD)
U.S. Patent 6,240,697B1

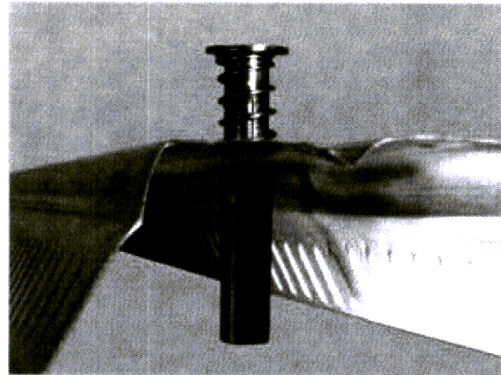
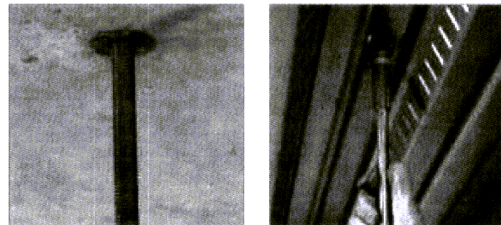

TEKS® FASTENER FEATURES

HEAD

Proper head style choice will ensure stability during driving, proper clamping and desired finished appearance.

THREAD FORM AND DIAMETER

The correct choice of thread form and diameter optimizes low installation torque with high pullout strength.

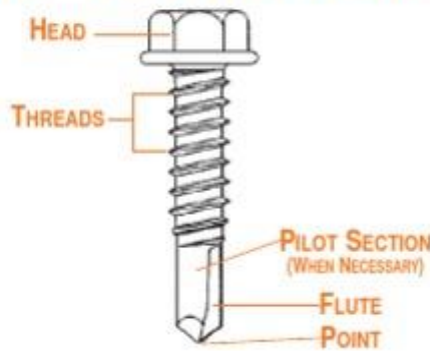

PILOT SECTION

The unthreaded portion of the point assures that the drilling of the steel is completed before the threads begin tapping into the drilled hole.

POINT

The point is designed to efficiently remove material and precisely size the hole for the thread.

FINISH: Platings and coatings provide lubricity during drilling and tapping as well as corrosion resistance.

FASTENER DESCRIPTION AND BREAKDOWN - EXAMPLE

10	-	16	x	3/4"	HWH	TEKS/3
Nominal Screw Size		Threads Per Inch		Screw Length	Head Style	Drill Point Type

NOMINAL SCREW SIZES		STEEL GAUGE CHART		DRILL AND TAP MATERIAL THICKNESS CHART											
THREAD DIAMETER	DECIMAL EQUIVALENT	COMMON SHEET STEEL GAUGES	DECIMAL EQ. INCHES MM												
#6	.140	30	.012 .30												
#7	.150	28	.015 .38												
#8	.160	26	.018 .45												
#9	.180	24	.024 .61												
#10	.190	22	.030 .76												
#11	.200	20	.036 .91												
#12	.210	18	.048 1.21												
#13	.230	16	.060 1.52												
#14	.240	14	.075 1.90												
1/4	.250	12	.105 2.65												
#17	.286	10	.134 3.42												
		3/16	.187 4.77												
		1/4	.250 6.36												
		1/2	.500 12.72												

Screw Size	Point	Teks/1	Teks/2	Teks/3	Teks/4	Teks/4.5	Teks/5
#10	45mm	.095	.100	.175	.250	.375	.500
#12	45mm	.095	.100	.175	.250	.375	.500
1/4	45mm	.095	.100	.175	.250	.375	.500
#8	91mm	.036	.036	.036	.036	.036	.036
#12	91mm	.036	.036	.036	.036	.036	.036
1/4	91mm	.036	.036	.036	.036	.036	.036
#12	113mm	.125	.125	.125	.125	.125	.125
1/4	113mm	.125	.125	.125	.125	.125	.125
#12	135mm	.125	.125	.125	.125	.125	.125
#12	157mm	.125	.125	.125	.125	.125	.125
1/4	157mm	.125	.125	.125	.125	.125	.125

*Drill & tap capacities may vary with special feature designs. Refer to product reports for specifics.

Driv-Tru™ HWH SOCKET SYSTEM

Selector Guide



Part No.	Description	Applications
1591910	Driv-Tru Socket	All 1/4" across flats HWH fasteners
1513910	Driv-Tru Socket	All 5/16" across flats HWH fasteners
1574910	Driv-Tru Socket	All 3/8" across flats HWH fasteners

ACQ Tested Coatings*

The following fasteners have been tested with ACQ (Alkaline Copper Quaternary) treated wood: DEC-KING® Exterior wood screw with Climacoat®, Tapcon® Concrete Anchors with Blue Climaseal® and White UltraShield™, Wood-to-Metal TEKS® with Grey Spex™, Roofgrip® with Spex or Blue Climaseal and Maxi-Set Tapcon® with White UltraShield.

* Due to the many test variables involved, the lack of a correlation between test results and service in the field, and the corrosive nature of ACQ treated wood, ITW Buildex cannot guarantee the performance of any fasteners. Use of any ITW Buildex fasteners can lead to corrosion problems that may limit the life of a structure and pose safety concerns. The decision as to the suitability of a fastener for use in treated wood is the sole responsibility of the design professional of record. Should you have any questions, please feel free to call the Technical Services Department at (800) 323-0720.

Warranty Information

Proper fastener connection design takes into account where and how fasteners are used. Allowance for special characteristics in materials, differences in types of materials being joined, unique or unusual environmental service or installation conditions and the safety factors required by anticipating normal or short term loading conditions must be considered. Due to possible differences in specifications, applications and interpretation of results, purchasers and specifiers must make their own evaluation of the products, to determine the suitability of these products for intended use. All warranties of Buildex products, expressed or implied, including the warranties of merchantability and fitness for particular purposes are specifically excluded except for the following: Buildex will repair or replace any product which, within twelve months after sale by Buildex or its distributors, is found by Buildex to be defective in material or workmanship -- normal wear and tear excepted. This is the sole warranty of Buildex and the sole remedy available to distributor or buyer. Buildex shall not be liable for any injury, loss or damage, direct, indirect, incidental or consequential, arising out of the use of, or the inability to use, any Buildex product.

Hex Washer Head Tek Screws - Domestic

Finish: #8 - Electro-Galvanized

#10 - Climaseal

Manufacturer: ITW Buildex

Applications:

- Stitch roof deck and wall panel sidelaps
- HVAC, electrical trim accessories to steel framing
- Residential steel frame construction
- Brick toes to steel framing
- Track to stud and stud splicing
- Hat channel to stud



Approvals: Factory Mutual (J.I. 2 x 9A2 AM), ICC ESR-1976

Climaseal finish provides excellent corrosion resistance and lower tapping torque.

Description	Head Style	Drill Point	Drill & Tap Capacity	Max. Material Attachment	Box Qty.
8-18 x 1/2	HWH	#2	.036 - .100	.205	10,000
8-18 x 3/4	HWH	#2	.036 - .100	.455	10,000
8-18 x 1	HWH	#2	.036 - .100	.705	8,000
8-18 x 1-1/2	HWH	#2	.036 - .100	1.205	4,000
10-16 x 1/2	HWH	#3	.036 - .175	.150	5,000
10-16 x 3/4	HWH	#3	.036 - .175	.325	5,000
10-16 x 1	HWH	#3	.036 - .175	.575	5,000
10-16 x 1-1/2	HWH	#3	.036 - .175	1.075	3,000

Performance Data

PULLOUT VALUES (average lbs. ultimate)									
Fastener		Steel Gauge							
Dia.	Pt.	26	24	22	20	18	16	14	12
#6	2	120	183	248	296	471	679	847	-
#8	2	119	193	265	298	491	703	959	-
#10-16	1	148	241	311	357	565	826	1111	1796
	3	124	208	266	299	499	708	967	1474
#12	1	159	261	338	390	649	908	1259	1949
1/4	1	208	329	428	562	800	1151	-	-

SHEAR VALUES (average lbs. ultimate)								
Fastener		Steel Gauge (lapped)						
Dia.	Pt.	26	24	22	20	18	16	14
#6	2	278	466	526	758	845	-	-
#8	2	294	496	560	740	1060	-	-
#10	1	398	584	659	884	1374	-	-
	3	-	455	526	728	1266	1540	1552
#12	1	432	703	753	1018	1452	-	-
1/4	1	511	849	885	1244	1764	-	-

FASTENER VALUES			
Fastener (dia-tpi)	Tensile (lbs. min.)	Shear (avg. lbs. ult.)	Torque (min. in. lbs.)
6-20	1285	750	25
8-18	1545	1000	42
10-16	1936	1400	61
10-24	2702	1500	65
12-14	2778	2000	92
1/4-14	4060	2600	150

The values listed are ultimate averages achieved under laboratory conditions and apply to Buildex manufactured fasteners only. Appropriate safety factors should be applied to these values for design purposes.

Hex Washer Head Tek Screws - Domestic

Finish: Climaseal

Manufacturer: ITW Buildex



Applications:

- Rood Deck to steel framing
- Wall Panel to girt
- Duct work to steel framing
- Accessories to steel framing
- Roof clip to steel framing
- Retrofit framing
- Commercial overhead steel doors, hinges & latches

Approvals: Factory Mutual (J.I. 2 x 9A2 AM), ICC ESR-1976

Climaseal finish provides excellent corrosion resistance and lower tapping torque.

Description	Head Style	Drill Point	Drill & Tap Capacity	Max. Material Attachment	Box Qty.
12-14 x 3/4	HWH	#3	.036 - .210	.270	5,000
12-14 x 1	HWH	#3	.036 - .210	.520	4,000
12-14 x 1-1/2	HWH	#3	.036 - .210	.800	2,500
12-14 x 2	HWH	#3	.036 - .210	1.450	2,000
12-14x 2-1/2	HWH	#3	.036 - .210	1.950	1,000
12-14 x 3	HWH	#3	.036 - .210	2.450	1,000
12-14 x 4	HWH	#3	.036 - .210	3.450	500
1/4-14 x 3/4	HWH	#3	.036 - .210	.210	3,000
1/4-14 x 1	HWH	#3	.036 - .210	.400	2,500
1/4-14 x 1-1/2	HWH	#3	.036 - .210	.900	2,000
1/4-14 x 2	HWH	#3	.036 - .210	1.400	1,500
1/4-14 x 3	HWH	#3	.036 - .210	2.400	1,000
1/4-14 x 4	HWH	#3	.036 - .210	3.400	500

PULLOUT VALUES (average lbs. ultimate)										
Fastener		Steel Gauge								
Dia.	Pt.	26	24	22	20	18	16	14	12	3/16
#12	2	156	243	283	375	605	848	1181	1856	3520
	3	142	211	289	341	551	757	1063	1631	2998
1/4	3	141	231	293	346	613	880	1145	1858	4550

SHEAR VALUES (average lbs. ultimate)										
Fastener		Steel Gauge (lapped)								
Dia.	Pt.	26	24	22	20	18	16	14	12	
12	2	365	600	623	898	1370	1758	2138	2202	
	3	-	-	-	769	1358	1620	1970	1986	
1/4	3	-	-	-	930	1442	2100	2584	2650	

FASTENER VALUES			
Fastener (dia-tpi)	Tensile (lbs. min.)	Shear (avg. lbs. ult.)	Torque (min. in. lbs.)
12-14	2778	2000	92
1/4-14	4060	2600	150

The values listed are ultimate averages achieved under laboratory conditions and apply to Buildex manufactured fasteners only. Appropriate safety factors should be applied to these values for design purposes.

Hex Washer Head Tek Screws - Domestic

Finish: Climaseal

Manufacturer: ITW Buildex



Applications:

- Metal deck to structural steel or bar joist
- Clips to structural steel or bar joist
- Liner panels to structural steel or bar joist
- Accessories to structural steel or bar joist
- Longer length fasteners can be used in retrofit clip and sheet applications

Approvals: Factory Mutual (J.I. 2 x 9A2 AM), ICC ESR-1976

Climaseal finish provides excellent corrosion resistance and lower tapping torque.

Description	Head Style	Drill Point	Drill & Tap Capacity	Max. Material Attachment	Box Qty.
12-24 x 7/8	HWH	4	.125 - .250	.325	5,000
12-24 x 1-1/4	HWH	4.5	.125 - .375	.575	4,000
12-24 x 1-1/2	HWH	5	.125 - .500	.625	2,500
12-24 x 2	HWH	5	.125 - .500	1.125	2,000
12-24 x 3	HWH	5	.125 - .500	2.150	1,000

PULLOUT VALUES (average lbs. ultimate)						
Fastener		Steel Gauge				
Dia.	Pt.	16	14	12	3/16	1/4
#12	4	-	-	1532	3485	3844
	4.5	-	-	1508	3865	4101
	5	-	-	1527	3701	3999
1/4	5	-	-	1507	3300	5059

SHEAR VALUES (average lbs. ultimate)						
Fastener		Steel Gauge (lapped)				
Dia.	Pt.	16	14	12	1/8	1/4
#12	4	-	-	2048	2030	-
	4.5	-	-	2641	2887	2897
	5	-	-	2650	2700	2762
1/4	5	1597	2005	2350	2792	3310

FASTENER VALUES			
Fastener (dia-tpi)	Tensile (lbs. min.)	Shear (avg. lbs. ult.)	Torque (min. in. lbs.)
12-24 T/4	3020	2100	100
12-24 T/4.5	3020	2100	100
12-24 T/5	3020	2100	100
1/4-28 T/5	5577	3310	234

FIRE CAULKING

PRODUCT DATA SHEET

May 2000



Metacaulk® 1000 Firestopping Sealant

Classified System Numbers TRC/PV 80-03, TRC/PV 120-13, TRC/PV 120-15, TRC/PV 120-17, CAJ 2112, CAJ 2113, CAJ 3086, CAJ 3087, CAJ 5070, CAJ 5077, CAJ 5078, CAJ 1221, CAJ 2120, CAJ 2119, CAJ 2122, CAJ 5085, CAJ 8050, CAJ 2134, CAJ1260, CAJ1261, CAJ1263, WL 5057, WL 5059, WL 5061, WL 5063, WL 2102, WL 2104, WL 2106, WL 1099, WL 1104, WL 1102, WL 1108, WL 1106, WL 2108, WL5075, WL1120, WL1110, WL1116, WL1114, WJ 5016, WJ 5018, WJ 5020, WJ 5022, WJ 2023, WJ 2025, WJ 2027, WJ 1036, WJ 1038, WJ5029, WJ1045, WJ1043, FC 1030, FC 1032, FC 2065, FC 5020, FC 5022, FC 2077, FC 2075, FC 2076, HWD 0014

1. Product Description

Metacaulk® 1000 is a one component, general purpose fire rated sealant and smoke seal for construction joints and through-penetrations. Metacaulk® 1000 is a water based, extremely intumescent, non-sag caulking grade sealant that is easy to apply as well as to retrofit. It cures to an elastomeric seal that is suitable where dynamic movement is expected. In the event of a fire, Metacaulk® 1000 will prevent the spread of flames, smoke, hot gases and water through joint openings and through-penetrations. No dilution or mixing is required for use. No special skills are necessary for installation. Metacaulk® 1000 is applied with a conventional caulking gun, bulk loading gun or can be troweled from the pail. For large applications, it can be pumped directly from the pail. Metacaulk® 1000 systems are rated for 1, 2, 3 and 4 hours in accordance with the ASTM E814 (UL1479), UL 2079 and CAN4-S115-M85 test standards.

Use Metacaulk® 1000 for various applications:

- Top of the Wall Construction Joints
- Deflection Track Wall Systems
- Up to 2" (51 mm)PVC (Open)
- Up to 3" (76 mm)PVC & ABS (Closed)
- Steel, Copper, Cast Iron and EMT Pipe
- Flexible Conduit
- Fiberglass Insulated Pipe
- Armaflex Insulated Pipe
- Telephone, Communication and Power Cables
- HVAC Ductwork

For a complete list of product applications or for additional technical

information, call RECTORSEAL for the latest updated information.

Metacaulk® 1000 Features

- Water Based
- Excellent Freeze-Thaw
- Flexible Set
- Highly Intumescent
- Paintable
- VOC Compliant
- Safe and Easy to Use
- Minimum 2 Year Shelf Life

2. Material Properties

Asbestos Fillers	None
Solvents	None
Hazardous Ingredients	None
Application	Caulking Gun or Trowel

Activation of Intumescence:

Expansion Begins	375° F (190°C)
Expansion Greatest	575° (302°) to 1100° F(593° C)

Color	Red
Cure Time	3 to 4 weeks (at 77° F/ 25°C)
Density	10.4 +/- 0.3 lbs./gal. 1.25 kg/L
Elastomeric	Yes
Freeze-Thaw	Excellent
Skin Over Time	30 min. (at 77° F/ 25°C)
pH Value	6.5 to 7
Volume Coverage:	
for 10.3 oz. tube (304ml)	18 cu. in. (295 cc)
for 5 gallon (18.9 liter)	1155 cu. in. (5000 cu. cm/L)

VOC Negligible

ASTM E 84, UL 723 Tunnel Test

Flame Spread	5
Smoke Index	10

3. Applications

Metacaulk® 1000 can be used in interior applications as a general purpose fire rated sealant and smoke seal for construction joints on both vertical and horizontal surfaces. Metacaulk® 1000 is also an excellent fire rated acoustical sealant and can be used in areas under constant vibration or movement. Metacaulk® 1000 can also be used on various



penetrations such as EMT, telephone & power cables, insulated pipes, etc. in concrete floors and walls, gypsum walls as well as wood floors. Use Metacaulk® 1000 to prevent the spread of fire and smoke through joints in fire rated gypsum wallboard partitions, concrete block or concrete walls and/or concrete or corrugated steel deck floor/ceiling assemblies.

4. Installation Data

Install Metacaulk® 1000 using standard caulking techniques or trowel from pails. Metacaulk® 1000 may also be pumped from the pails. When damming materials are needed, use only materials approved for the specific application.

TYPICAL TOP OF WALL INSTALLATION

Step 1)

Cut and fit the gypsum wallboard to the contour of the steel decking leaving a maximum 3/4" (19 mm) relief gap.

Step 2)

Pack the flute openings and relief gap with required amount of fiberglass insulation and recess to required depth.

Step 3)

Gun, trowel or pump the sealant as required to the specified depth. Properly tool sealant surface flush with the wall.

5. Testing Data

For specific test criteria, refer to the UL's Fire Resistance Directory or Warnock Hersey International Listing Directory or call RECTORSEAL

Metacaulk® 1000 was tested at positive pressure with a minimum 0.01 (2.5 Pa) inches water and in accordance with ASTM E814 (UL 1479), UL 2079 and CAN4-S115-M85.

10. LIMITED WARRANTY

RectorSeal makes the Limited Express Warranty that at the date of delivery this product will be free from defects in RectorSeal materials and workmanship. THIS LIMITED EXPRESS WARRANTY IS EXPRESSLY IN LIEU OF ANY OTHER EXPRESS OR IMPLIED WARRANTIES, INCLUDING ANY IMPLIED WARRANTY OF MERCHANTABILITY OR FITNESS FOR A PARTICULAR PURPOSE, AND OF ANY OTHER OBLIGATION ON THE PART OF RECTORSEAL. The sole remedy for breach of the Limited Express Warranty shall be the refund of the purchase price. All other liability is negated and disclaimed, and RectorSeal shall not be liable for incidental or consequential damages.

Suggestions and recommendations covering the use of our products are based on our past experience and laboratory findings. However, as we have no control as to the methods and conditions of application, we only assume responsibility for the uniformity of our products within manufacturing tolerances.

Systems tested by Warnock Hersey or UL Laboratories:

TRC/PV 60-03	TRC/PV 120-13
TRC/PV 120-15	CAJ 2112
CAJ 2113	CAJ 3086
CAJ 3087	CAJ 5070
CAJ 5077	CAJ 5078
CAJ 1221	CAJ 2120
CAJ 2119	CAJ 2122
WL 5057	WL 5059
WL 5061	WL 5063
WL 2102	WL 2104
WL 2106	WL 1099
WL 1104	WL 1102
WL 1108	WL 1106
WJ 5016	WJ 5018
WJ 5020	WJ 5022
WJ 2023	WJ 2025
WJ 2027	WJ 1036
WJ 1038	CAJ 5085
CAJ 8050	CAJ 2134
WL 2108	FC 1030
FC 1032	FC 2065
FC 5020	FC 5022
FC 2077	FC 2075
FC 2076	HWD 0014
WL 5075	WJ 5029
WL 1120	WJ 1110
WJ 1045	WJ 1116
WL 1114	WJ 1043
CAJ 1261	CAJ 1263
CAJ 1261	TRC/PV 120-17

6. Storage & Handling

Metacaulk® 1000 should be stored between 35°F (2°C) and 120°F (49°C) to obtain a minimum 2 year shelf life. NOTE: Do not dilute, no mixing is required. Best if protected from freezing. If freezing occurs, thaw completely before using. Keep products stored under protective cover in original containers.

7. Availability

Metacaulk® 1000 is available in 10.3 oz. (304 ml) and 30 oz. (887 ml) caulking tubes and in 5 gallon (18.9 L) pails.

8. Limitations

Metacaulk® 1000 is not designed to be used in areas under continuous immersion or in areas which would be continuously wet. Metacaulk® 1000 should not be used against hot uninsulated surfaces above 300° F (149° C).

9. Cautions

FOR CHEMICAL EMERGENCY, SPILL, LEAK, FIRE, EXPOSURE OR ACCIDENT, CALL CHEMTREC-DAY OR NIGHT 1-800-424-9300.

PRECAUTIONS: Do not take internally. May be harmful if swallowed. May cause eye and skin irritation if prolonged or repeated contact occurs. Wash after handling. **FIRST AID:** For any overexposure, get immediate medical attention after first aid is given. **Eyes-** Flush 15 minutes with clean water. **Skin-** Wash with soap and water. **Inhalation-** Remove to fresh air. **Ingestion-** Only if conscious, give large amounts of water and INDUCE VOMITING. **FIRE AND SPILLS:** Use water fog, CO₂, foam, or dry chemicals. Wipe up spills to prevent footing hazard. Clean up with scrapers and water. **STORAGE AND HANDLING:** Store away from heat sources. Keep container closed. Do not reuse empty container. **KEEP OUT OF REACH OF CHILDREN.**

For additional information, refer to Material Safety Data Sheet.

For additional technical service, call: 1-800-231-3345 fax: 1-800-452-2824

RECTORSEAL
2801 Spanwick Drive, HOUSTON, TEXAS 77055
WWW.RECTORSEAL.COM
WWW.METACAULK.COM

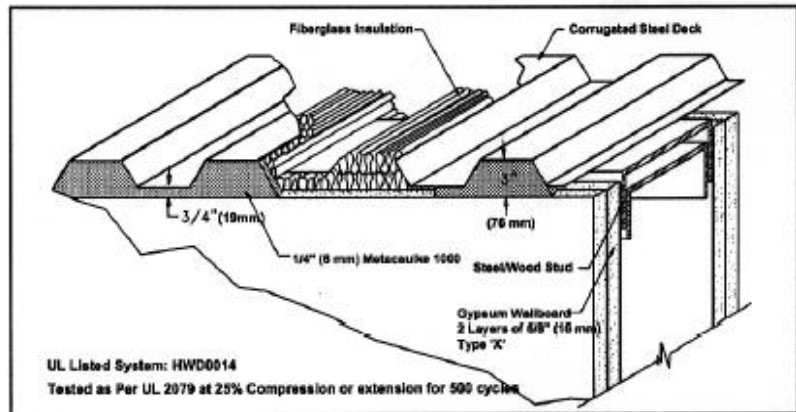

Product Data Sheet
Edition 5.13.2016
Sikaflex-1a

Sikaflex®-1a

One part polyurethane, elastomeric sealant/adhesive



Description	Sikaflex-1a is a premium-grade, high-performance, moisture-cured, 1-component, polyurethane-based, non-sag elastomeric sealant. Meets Federal specification TT-S-00230C, Type II, Class A. Meets ASTM C-920, Type S, Grade NS, Class 35, use T, NT, O, M, G, I; Canadian standard CAN/CGSB 19.13-M67.
Where to Use	<ul style="list-style-type: none"> Designed for all types of joints where maximum depth of sealant will not exceed 1/2 in. Excellent for small joints and fillets, windows, door frames, reglets, flashing, common roofing detail applications, and many construction adhesive applications. Suitable for vertical and horizontal joints; readily placeable at 40°F. Has many applications as an elastic adhesive between materials with dissimilar coefficients of expansion. Submerged conditions, such as canal and reservoir joints.
Advantages	<ul style="list-style-type: none"> Eliminates time, effort, and equipment for mixing, filling cartridges, pre-heating or thawing, and cleaning of equipment. Fast tack-free and final cure times. High elasticity - cures to a tough, durable, flexible consistency with exceptional cut and tear-resistance. Stress relaxation. Excellent adhesion - bonds to most construction materials without a primer. Excellent resistance to aging, weathering. Proven in tough climates around the world. Odorless, non-staining. Jet fuel resistant. Certified to the NSF/ANSI Standard 61 for potable water. Urethane-based; suggested by EPA for radon reduction. Paintable with water-, oil- and rubber-based paints. Capable of ±35% joint movement.
Chemical Resistance	Good resistance to water, diluted acids, and diluted alkalines. Consult Technical Service for specific data.
Packaging	10.1 fl. oz. (300 mL), 20 fl. oz. (591 mL), 4.5 gal (17 L) in a 5 gal pail, 52 gal (197 L) in a 55 gal drum

Typical Data (Material and curing conditions @ 73°F (23°C) and 50% R.H.)

RESULTS MAY DIFFER BASED UPON STATISTICAL VARIATIONS DEPENDING UPON MIXING METHODS AND EQUIPMENT, TEMPERATURE, APPLICATION METHODS, TEST METHODS, ACTUAL SITE CONDITIONS AND CURING CONDITIONS.

Shelf Life	10.1 fl. oz. cartridges	12 months
	20 fl. oz. uni-pac sausages	12 months
	5 gallon pail	6 months
	55 gallon drum	6 months
Storage Conditions	Store at 40°-95°F (4°-35°C). Condition material to 65°-75°F before using.	
VOC Content	40 g/L	
Colors	White, colonial white, aluminum gray, limestone, black, dark bronze, capitol tan, stone and medium bronze. Special architectural colors on request.	
Application Temperature	40° to 100°F. Sealant should be installed when joint is at mid-range of its anticipated movement.	
Service Range	-40° to 170°F	
Curing Rate	Tack-free time	3 to 6 hours
	Tack-free to touch	3 hours
	Final cure	4 to 7 days
Tear Strength (ASTM D-824)	55 lb./in.	
Shore A Hardness (ASTM C-881)	21 day	40±5
Movement Capability (ASTM C-718)	+/- 35%	
Tensile Properties (ASTM D-412)	21 day Tensile Stress	175 psi (1.21 MPa)
	Elongation at Break	550%
	Stress at 100%	85 psi (0.59 MPa)
Adhesion in Peel (TT-8-00230C, ASTM C 794)	Substrate Peel Strength	Adhesion Loss
	Concrete 20 lb.	0%
	Aluminum 20 lb.	0%
	Glass 20 lb.	0%
Weathering Resistance	Excellent	



PRIOR TO EACH USE OF ANY SIKA PRODUCT, THE USER MUST ALWAYS READ AND FOLLOW THE WARNINGS AND INSTRUCTIONS ON THE PRODUCT'S MOST CURRENT PRODUCT DATA SHEET, PRODUCT LABEL AND SAFETY DATA SHEET WHICH ARE AVAILABLE ONLINE AT [HTTP://USA.SIKA.COM](http://USA.SIKA.COM) OR BY CALLING SIKA'S TECHNICAL SERVICE DEPARTMENT AT 800.833.7462 NOTHING CONTAINED IN ANY SIKA MATERIALS RELIEVES THE USER OF THE OBLIGATION TO READ AND FOLLOW THE WARNINGS AND INSTRUCTIONS FOR EACH SIKA PRODUCT AS SET FORTH IN THE CURRENT PRODUCT DATA SHEET, PRODUCT LABEL AND SAFETY DATA SHEET PRIOR TO PRODUCT USE.

Coverage	10.1 oz Cartridge Yield in Linear Feet				20 oz Sausage Yield in Linear Feet				1 gallon Yield in Linear Feet			
	Depth	1/4"	3/8"	1/2"	Depth	1/4"	3/8"	1/2"	Depth	1/4"	3/8"	1/2"
Width	1/4"	24.3			1/4"	48.3			1/4"	207.9		
	3/8"	16.2	10.8		3/8"	22.1	21.4		3/8"	205.2	126.8	
	1/2"	12.1	8.1	6.1	1/2"	24.1	16.0	12.0	1/2"	152.9	102.6	77.0
	3/4"	8.1	5.4	4.0	3/4"	16.0	10.7	8.0	3/4"	102.6	68.4	51.3
	1"			2.0	1"			6.0	1"			38.5
	1.25"			2.4	1.25"			4.8	1.25"			30.8
	1.5"		2.0	1.5"			4.0	1.5"			25.7	

How to Use	Surface Preparation
Priming	Priming is not usually necessary. Most substrates only require priming if testing indicates a need or where sealant will be subjected to water immersion after cure. Consult Sikaflex Primer Technical Data Sheet or Technical Service for additional information on priming.
Application	Recommended application temperatures: 40°-100°F. For cold weather application, condition units at approximately 70°F; remove prior to using. For best performance, Sikaflex-1a should be gunned into joint when joint slot is at mid-point of its designed expansion and contraction. Place nozzle of gun into bottom of the joint and fill entire joint. Keep the nozzle in the sealant, continue on with a steady flow of sealant preceding the nozzle to avoid air entrapment. Avoid overlapping of sealant to eliminate entrapment of air.
Tooling and Finishing	Tool sealant to ensure full contact with joint walls and remove air entrapment. Joint dimension should allow for 1/4 inch minimum and 1/2 inch maximum thickness for sealant. Proper design is 2:1 width to depth ratio. For use in horizontal joints in traffic areas, the absolute minimum depth of the sealant is 1/2 in. and closed cell backer rod is recommended.
Removal	Use personal protective equipment (chemical resistant gloves/goggles/clothing). Without direct contact, remove spilled or excess product and placed in suitable sealed container. Dispose of excess product and container in accordance with applicable environmental regulations.
Over Painting	Allow 1-week cure at standard conditions when using Sikaflex-1a in total water immersion situations and prior to painting.
Limitations	<ul style="list-style-type: none"> When overcoating with water, oil and rubber based paints, compatibility and adhesion testing is essential. Sealant should be allowed to cure for 7 days prior to overcoating. Avoid exposure to high levels of chlorine. (Maximum continuous level is 5 ppm of chlorine.) Maximum depth of sealant must not exceed 1/2 in.; minimum depth is 1/4 in. Maximum expansion and contraction should not exceed 25% of average joint width. Do not cure in the presence of curing silicone sealants. Avoid contact with alcohol and other solvent cleaners during cure. Do not apply when moisture-vapor-transmission condition exists from the substrate as this can cause bubbling within the sealant. Use opened cartridges and uni-pac sausages the same day. When applying sealant, avoid air-entrapment. Since system is moisture-cured, permit sufficient exposure to air. White color tends to yellow slightly when exposed to ultraviolet rays. Light colors can yellow if exposed to direct gas fired heating element. The ultimate performance of Sikaflex-1a depends on good joint design and proper application with joint surfaces properly prepared. The depth of sealant in horizontal joints subject to traffic is 1/2 in. Do not tool with detergent or soap solutions. Do not use in contact with bituminous/asphaltic materials.

PRIOR TO EACH USE OF ANY SIKA PRODUCT, THE USER MUST ALWAYS READ AND FOLLOW THE WARNINGS AND INSTRUCTIONS ON THE PRODUCT'S MOST CURRENT PRODUCT DATA SHEET, PRODUCT LABEL AND SAFETY DATA SHEET WHICH ARE AVAILABLE ONLINE AT [HTTP://USA.SIKA.COM/](http://usa.sika.com/) OR BY CALLING SIKA'S TECHNICAL SERVICE DEPARTMENT AT 800.833.7462. NOTHING CONTAINED IN ANY SIKA MATERIALS RELIEVES THE USER OF THE OBLIGATION TO READ AND FOLLOW THE WARNINGS AND INSTRUCTIONS FOR EACH SIKA PRODUCT AS SET FORTH IN THE CURRENT PRODUCT DATA SHEET, PRODUCT LABEL AND SAFETY DATA SHEET PRIOR TO PRODUCT USE.

KEEP CONTAINER TIGHTLY CLOSED. KEEP OUT OF REACH OF CHILDREN. NOT FOR INTERNAL CONSUMPTION. FOR INDUSTRIAL USE ONLY. FOR PROFESSIONAL USE ONLY.
For further information and advice regarding transportation, handling, storage and disposal of chemical products, users should refer to the actual Safety Data Sheets containing physical, ecological, toxicological and other safety related data. Read the current actual Safety Data Sheet before using the product. In case of emergency, call CHEMTREC at 1-800-424-6300, International 703-627-3887.

Prior to each use of any Sika product, the user must always read and follow the warnings and instructions on the product's most current Product Data Sheet, product label and Safety Data Sheet which are available online at <http://usa.sika.com/> or by calling Sika's Technical Service Department at 800-833-7462. Nothing contained in any Sika materials relieves the user of the obligation to read and follow the warnings and instruction for each Sika product as set forth in the current Product Data Sheet, product label and Safety Data Sheet prior to product use.

Sika warrants this product for one year from date of installation to be free from manufacturing defects and to meet the technical properties on the current Product Data Sheet if used as directed within shelf life. User determines suitability of product for intended use and assumes all risks. Buyer's sole remedy shall be limited to the purchase price or replacement of product exclusive of labor or cost of labor. NO OTHER WARRANTIES EXPRESSED OR IMPLIED SHALL APPLY INCLUDING ANY WARRANTY OF MERCHANTABILITY OR FITNESS FOR A PARTICULAR PURPOSE. SIKA SHALL NOT BE LIABLE UNDER ANY LEGAL THEORY FOR SPECIAL OR CONSEQUENTIAL DAMAGES. SIKA SHALL NOT BE RESPONSIBLE FOR THE USE OF THIS PRODUCT IN A MANNER TO INFRINGE ON ANY PATENT OR ANY OTHER INTELLECTUAL PROPERTY RIGHTS HELD BY OTHERS. SALE OF SIKA PRODUCTS ARE SUBJECT SIKA'S TERMS AND CONDITIONS OF SALE AVAILABLE AT [HTTP://USA.SIKA.COM/](http://usa.sika.com/) OR BY CALLING 201-933-8800.

Visit our website at usa.sika.com 1-800-833-SIKA NATIONWIDE
Regional Information and Sales Centers. For the location of your nearest Sika sales office, contact your regional center.

Sika Corporation 201 Polito Avenue Lyndhurst, NJ 07071 Phone: 800-933-7462 Fax: 201-933-6225	Sika Canada Inc. 601 Delmar Avenue Pointe Claire Quebec H3R 4A9 Phone: 514-697-2610 Fax: 514-694-2792	Sika Mexicana S.A. de C.V. Carretera Libre Celaya Km. 8.5 Fracc. Industrial Balvanera Carrizalora, Queretaro C.P. 76920 Phone: 52 442 2385800 Fax: 52 442 2250537
---	---	--

   
Sika and Sikaflex are registered trademarks. Printed in Canada.