



# 5<sup>th</sup> Wheel Travel Trailer Systems

- Automatic 4pt & 6pt Leveling
- 2pt Front Landing Gear



*Bigfoot Leveling Systems*  
Quadra Manufacturing  
305 US 131 South  
White Pigeon, MI 49099  
800-752-9815  
bigfootleveler.com

## Three available systems...

### Original Automatic

- Fully Automatic Leveling
- Simple Operation
- Quad Pump System



### Gen2 Automatic

- Fully Automatic Leveling
- Auto-reconnect Memory
- Wireless Key Fob
- Quad Pump System



### 2pt Control

- Front Landing Gear
- Individual Operation
- Weatherproof



## Gen2: Operation Instructions

### Set-up #1: Programming Your Sensor

1. Turn panel OFF, press FRONT 10 times, then press REAR 10 times.
2. Follow the instructions on the screen for selecting ONE sensor using the arrows on the left side of the panel.
3. Place a carpenter's level on the inside of your trailer (countertop, refrigerator or floor).
4. Manually operate by pressing FRONT, RIGHT, LEFT & REAR buttons to get the trailer level from front to back and side to side.
5. Once level in both directions press ENTER. You're done.

*From this point forward when you press AUTO LEVEL your trailer will return to this position.*

---

### Set-up #2: Programming your key fob to your control panel

1. Turn panel off
2. Press LEFT 5 times, then RIGHT 5 times
3. Press any button on key fob, PROGRAMMED.

*The key fob has an automatic shut off after 10 seconds of no use, to activate the fob simply press the BLUE button.*

## Gen2: Getting to know your controls...

Use the arrows to scroll through the main menu for function selection. Power shut-off switch not shown.

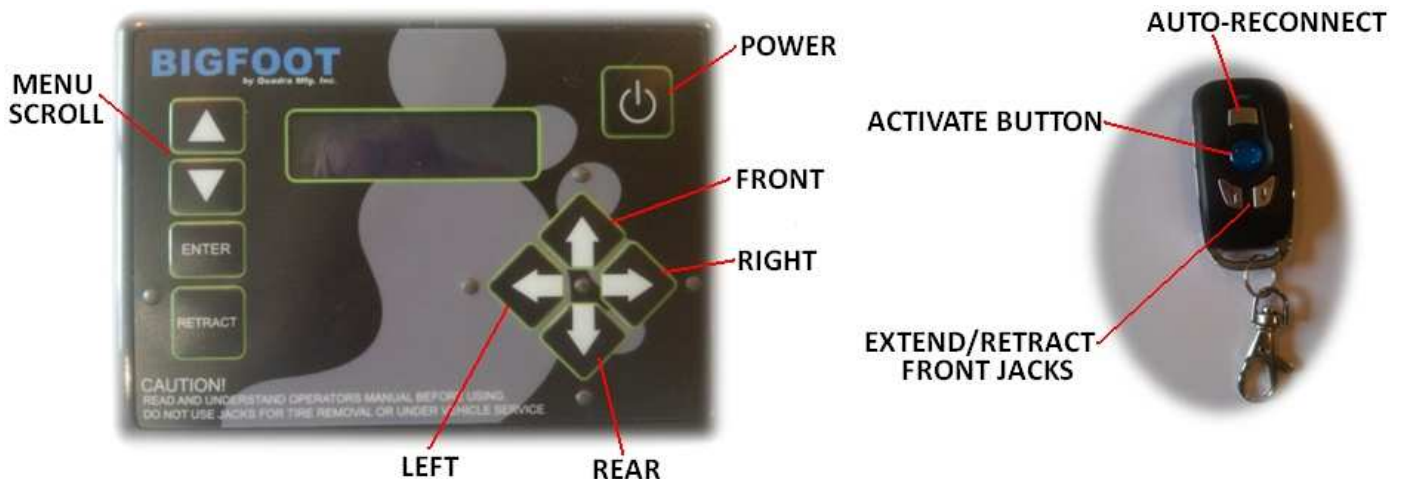

## Gen2: How to “un-hook” from vehicle:

### Using Control Panel:

1. With vehicle parked & hitch disconnected, press the “POWER” button to turn system on.
2. Use the FRONT button to raise the front of the trailer off the vehicle.
3. Pull the vehicle safely away from the trailer.

### Using Key fob:

1. Press & hold “ACTIVATE BUTTON” for 5 seconds or until panel beeps.
2. Press the DOWN button to extend the front 2 jacks and lift the front of your trailer.
3. Key fob will shut off automatically after 10 seconds.

---

## Gen2: How to use the AUTO LEVEL feature:

1. Make sure the vehicle is safely disconnected and out of the way.
2. Scroll through the main menu to AUTO LEVEL, press ENTER.
3. Once the trailer is level, the screen will prompt SUCCESS in the window.

---

## Gen2: How to use the MANUAL LEVELING feature:

1. Scroll through the main menu to MANUAL, press ENTER.
2. Press REAR to extend the rear 2 jacks until the trailer moves (each button operates 2 jacks).
3. Raise or lower the front 2 jacks to your preference using the FRONT button.
4. To operate individual jacks... <sup>EX.</sup> Driver’s side front leg, press FRONT & LEFT at the same time.

---

## Gen2: How to “hook-up” to vehicle:

### Using Control Panel:

1. Scroll to the AUTO RECONNECT feature on the menu, press ENTER. This will retract the rear jacks and extend the front jacks, lifting your trailer to the same height at which you previously disconnected from (within about 1”).
2. Once this mode is complete, back vehicle into loading position.
3. Press RETRACT, then FRONT until the trailer is placed onto vehicle.

### Using Key fob:

1. Press & hold “ACTIVATE BUTTON” for 5 seconds or until panel beeps.
2. Simply press the “AUTO RECONNECT BUTTON” to activate the AUTO RECONNECT feature described above.

## Gen2: Understanding “Lift to Connect” or “Auto Reconnect” mode:

This will retract the rear jacks and extend the front jacks, lifting the trailer to the previous unloading/disconnect position within an inch. This mode can be done by the Panel (Lift to Connect) or by the single grey button above the blue button on the key fob. **This mode will not work if you have not successfully completed the Auto Level Process.** Once this mode is complete, you may back your truck under the unit and lower your front jacks. On your panel, press RETRACT then FRONT until the trailer is lowered on the vehicle safely, then until the jacks are fully retracted. On the key fob, press the “UP” arrow until the trailer is lowered on the vehicle safely, then until the jacks are fully retracted.

# 2pt Control Operation & Installation

- Press & Hold the selected toggle switch to operate the corresponding jack individually
- Or press & hold both switches in unison to operate both jacks simultaneously.

## MEDIUM TANK ASSEMBLY

#M26850

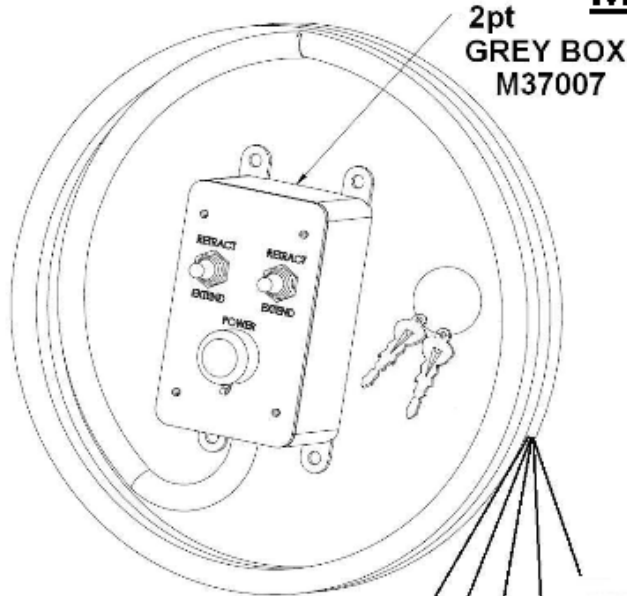

OVERALL DIMENSIONS:  
9" WIDE  
12.5" TALL  
5.75" DEEP

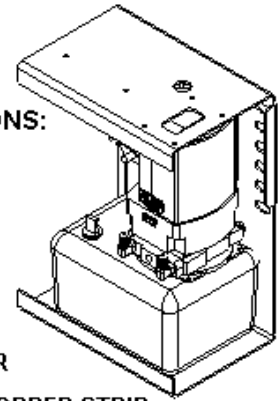

GREEN WIRE  
FROM MOTOR

COPPER STRIP  
#M12200

PUMP MOTOR  
#M35201

**GREEN w/ WHITE  
OR BLUE w/ WHITE  
WIRE FROM BOX**  
RETRACT SOLENOID  
OPERATION POST

**RED WIRE  
FROM BOX**

4 GA. BATTERY CABLE  
ONE END HERE THEN  
TO BREAKER MARKED 'AUX'  
THEN FROM POST MARKED 'BAT'  
TO POSITIVE TERMINAL  
ON BATTERY

**GREEN WIRE  
OR BLUE WIRE  
FROM BOX**  
EXTEND SOLENOID  
OPERATION POST

BLUE WIRE  
FROM MOTOR

BLACK GROUND WIRE  
FROM MOTOR

VENTED FILL CAP

**1pt GREY BOX (#M37022)**  
WIRES UP THE SAME WAY  
(ONLY ONE SWITCH & ONE SET OF WIRES)

64 oz. PLASTIC  
RESERVOIR  
#M25500

EXTEND  
90° JIC FITTING  
#M57007

RETRACT  
90° JIC FITTING  
#M57007

**NOT PICTURED:**

TANK COVER (BLACK TEXTURED PLASTIC) #M12002

5/9/11 **QUADRA**  
MANUFACTURING

# Original Automatic Leveling: Operation & Programming

1. Turn panel/system on and let system run through its diagnostic mode. Lights will flash clockwise around the green foot. When the lights stop flashing, you can now operate the system.

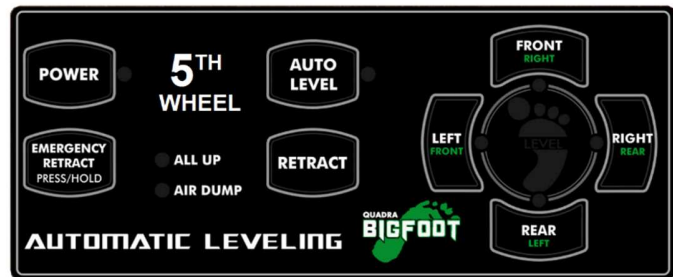

2. To un-hook, press and hold “Front” until the proper height of the trailer is reached to remove your truck.
3. To use the “Auto Level” feature, simply press and release. Movement in the coach during operation will disrupt the leveling process.
4. Ready to leave? To retract the levelers simply turn panel on and press “Retract” and release to retract the **rear jacks only**, this allows you to re-hook your truck.
5. To operate the front jacks, press and hold the “Front” and “Retract” buttons until you can hook the truck up and then resume process until jacks are completely retracted.

## Programming the Original Automatic Leveling System

1. Turn panel/system on and let system run through its diagnostic mode. Lights will flash clockwise around the green foot.
2. When the lights stop flashing, push the button labeled “FRONT” 10 times. Then press the button labeled “REAR” 10 times. Once you have done this all lights on panel will begin to flash. This means you have reached in the system what is called zero mode. At this time you can operate each corner or pair of levelers individually.

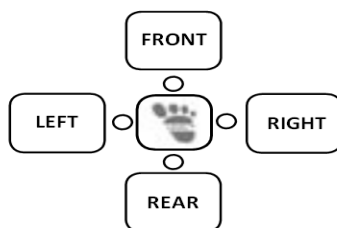

**FRONT** indicator operates the right front.

**RIGHT** operates the right rear.

**REAR** operates the left rear.

**LEFT** operates the left front.

Keep in mind the twisting/flexing of the vehicle’s frame. Try to operate jacks in pairs when possible.

3. Once you have the coach level, you can now store a new program into the system. To do so, press the RETRACT button 3 times. If you do not want to store a new program, simply retract jacks in manual mode to avoid changing the original program (press and hold RETACT & jack button).

# Standard 5<sup>th</sup> Wheel Jacks & Brackets

THIS SURFACE OF WELD-ON BRACKET TO BE WELDED TO TRAILER FRAME.  
(BEST TO PRE-ASSEMBLE JACK TO BRACKET, SET IN PLACE, VERIFY JACK IS STRAIGHT,  
PROPER GROUND CLEARANCE, THEN TACK WELD IN PLACE, REMOVE JACK FOR FULL WELD)

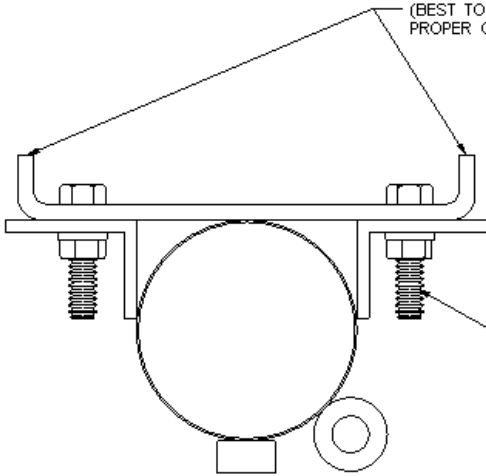

MINIMUM SIX PER JACK:  
7/16" HEX BOLT x 1.75" LONG  
7/16" HEX NUT & LOCKWASHER  
TIGHTEN TO 70 ft/lbs.

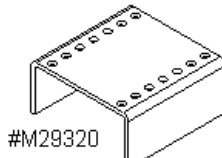
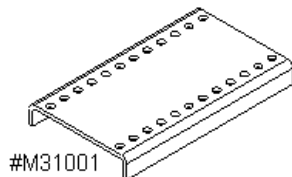
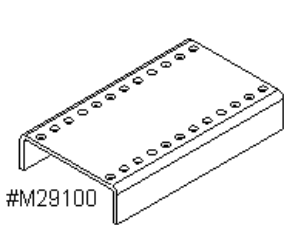

LIMIT SWITCH  
BARREL

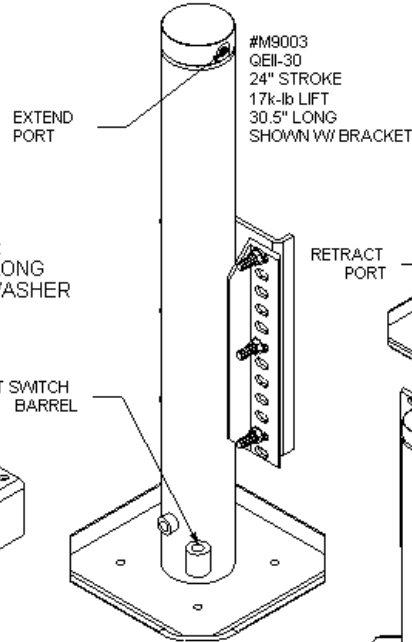

#M1024  
QEII-24  
24" STROKE  
12k-lb LIFT  
28.5" LONG

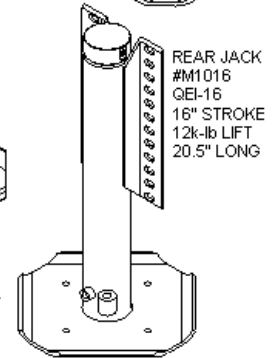

THIS SURFACE OF PART #M28782 TO BE WELDED TO TRAILER FRAME.  
(BEST TO PRE-ASSEMBLE JACK TO BRACKET, SET IN PLACE, VERIFY JACK IS STRAIGHT,  
PROPER GROUND CLEARANCE, THEN TACK WELD IN PLACE,  
REMOVE JACK FOR FULL WELD)

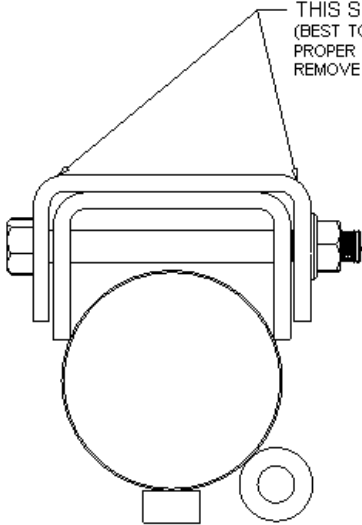

MINIMUM TWO PER JACK:  
1/2" HEX BOLT x 5.5" LONG  
1/2" HEX FLANGE LOCK NUT  
TIGHTEN TO 70 ft/lbs.

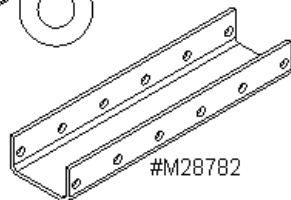

10" FOOT PAD  
#M27500

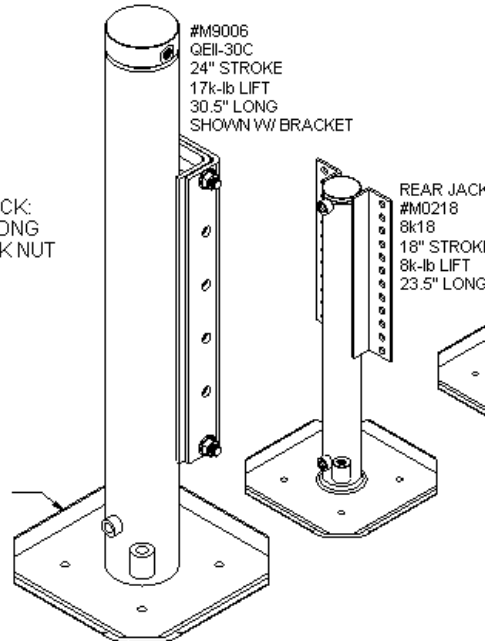

REAR JACK  
#M1300  
QEII-24  
18" STROKE  
17k-lb LIFT  
24.5" LONG

Applications may vary and your trailer may be equipped with different jacks not shown above due to your trailer manufacturer's requirements. For any installation questions or additional information visit our website at [bigfootleveler.com](http://bigfootleveler.com) or simply call 800-752-9815.

## Basic Installation Instructions

**Rear jack assembly:** Bracket may vary depending on application. Rear jack location should be within 5 ft behind the rear axle on the outside of the frame. If it is a six point the “center” row of jacks should be in front of the rear axle and typically within 10 ft from the rear jacks. Typical installation includes mounting the jacks to the weld-on bracket then welding the assembly to the frame. Attach the jack with four 7/16” x 1.75” bolts, nuts & lock washers (minimum of 6 per 17k-lb or 24k-lb jack) tighten to 70 ft/lbs. Prior to welding the assembly to the desired location, make sure the jack is straight and level and also between 8” and 11” of ground clearance from the bottom of the jack to the ground. Make sure there is a minimum of 4” of good weld per side of each bracket. Slide outs can cause issues with the rear jack location, typically the linkage/shaft is in the way of the weld-on bracket. What can be done is to slot each side of the bracket so there is plenty of room for that shaft to spin freely. If the supplied bracket is not “deep” enough, the bracket must be professionally extended to clear the shaft.

After welding, place the ¼” pin into the limit switch barrel and install the limit switch with a 7/8” wrench (See diagram on next page). The wires on the limit switch will go to the matching spade connector from the main wire harness and the eyelet will go to a ground on the frame or to a stud on the tank assembly. Now attach the elbow fittings to the top and bottom ports (top port is extend) with a 5/8” wrench (make sure to not over-tighten). Mount the tank assembly to the rear jacks utilizing the same mounting bolts you used to fasten the jacks down or use the 7/16” x 1.5” full threaded bolts on the jack bracket to mount the pump.

Time for **plumbing**, on four point systems simply install the corresponding length hose from the bottom port on the jack to the right port on the pump and the top extend port on the jack to the left port on the pump. If installing a **six point**, the two rear jacks will be “slaved” together (See diagram on next page). This means install the “tee” fittings to the rear jack with the pump attached. Then install the short hoses from the “tee” fittings to the corresponding ports on the pump. The other lines will go from the “tee” fittings to the center row jacks, bottom port to bottom port. The jacks are now slaved. The pump assembly may mount directly to the jack bracket or bolt to the frame.

**Front Jacks** will be located at the front of the trailer, usually inside the front storage compartment (sometimes front wall may have to be temporarily removed to access proper jack location on frame). Any existing jacks and their brackets will typically have to be removed to make room for the Bigfoot jacks. Front installations can be tricky on 5<sup>th</sup> wheels due to lack of space in those compartments and finding frame to weld too. There are two versions of the front jacks the channel style and the standard style (See 5<sup>th</sup> wheel jacks page). Make sure you use the QEII-30 or QEI-24 jacks and at minimum 12” long weld-on brackets. Get the most weld you can on the front brackets to the frame. Prior to all welding verify jacks are straight/level and the bottom of the jack & footpad clear the outside/bottom of the trailer nicely without an excessive amount hanging down. Install limit switch, tanks and plumbing as you did for the rear jacks (front jacks are never slaved together). Front jacks need at minimum six 7/16” x 1.75” bolts per jack or two 1/2” x 5.5” bolts (channel style) per jack.



## Limit Switch Assembly

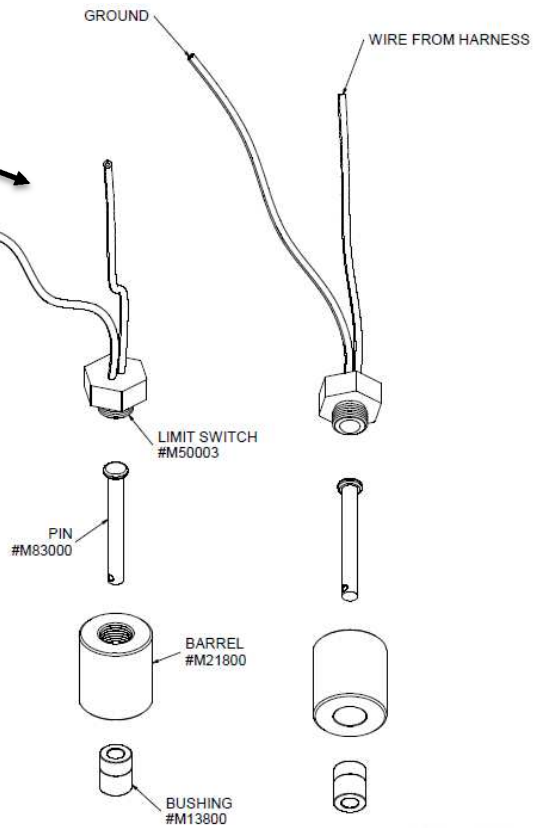

## Plumbing "Slave" Setup

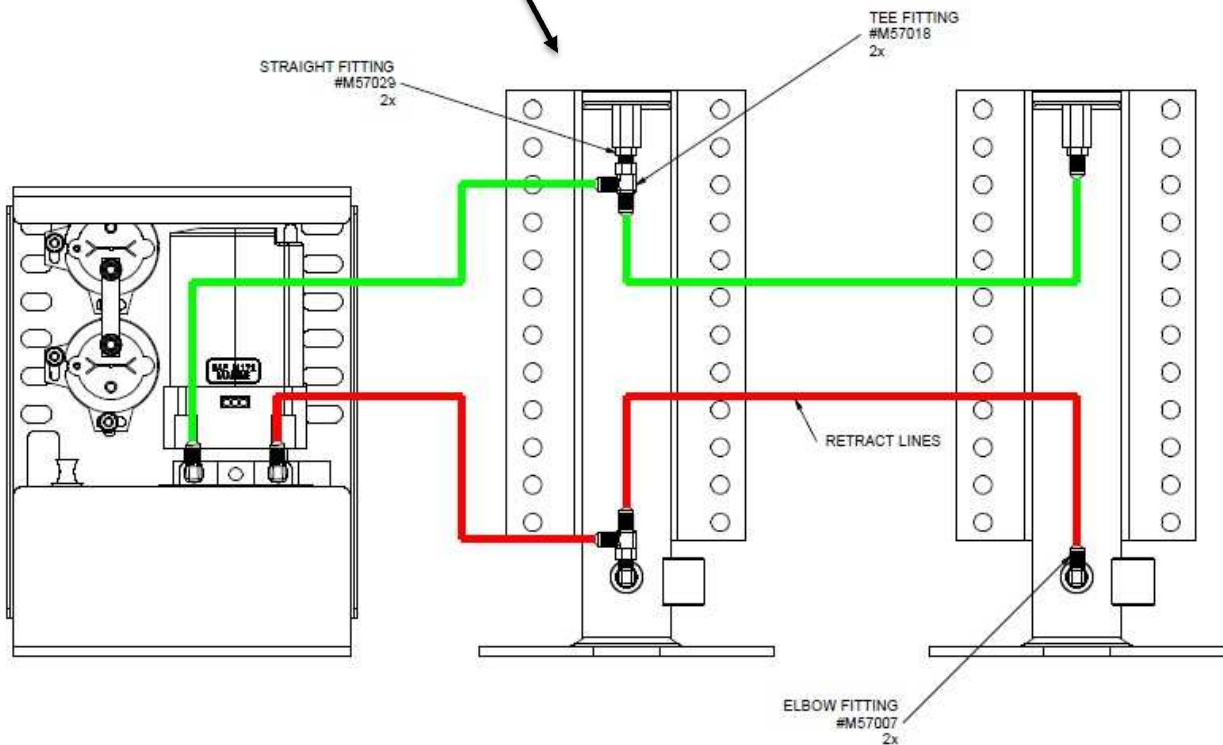

VERSION #1: (SHOWN) THE "TEE" FITTINGS MOUNTED TO THE DRIVE JACK.

VERSION #2: INCLUDES MOUNTING THE "TEE" FITTINGS TO THE PUMP FITTINGS.

VERSION #3: RUNNING TWO LINES FROM THE PUMP AND PLACING THE "TEE" FITTINGS IN-LINE, THEN RUNNING INDIVIDUAL LINES TO EACH JACK FROM THE "TEE" FITTINGS.

**Mounting Tank Assemblies:** Our tank assemblies are weather resistant and must be mounted vertically and can be mounted externally on the trailer's frame by drilling holes in the frame or welding a bracket, tanks can be mounted to a cylinder bracket or inside a storage box. Use at minimum two 7/16" bolts per tank assembly. Take care when mounting and running hydraulic lines & wiring to avoid moving parts, exhaust, etc.

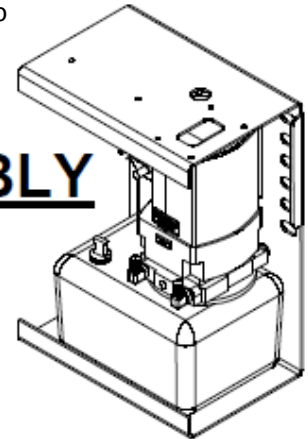

## **MEDIUM TANK ASSEMBLY**

#M26850

**OVERALL DIMENSIONS:**

9" WIDE  
12.5" TALL  
5.75" DEEP

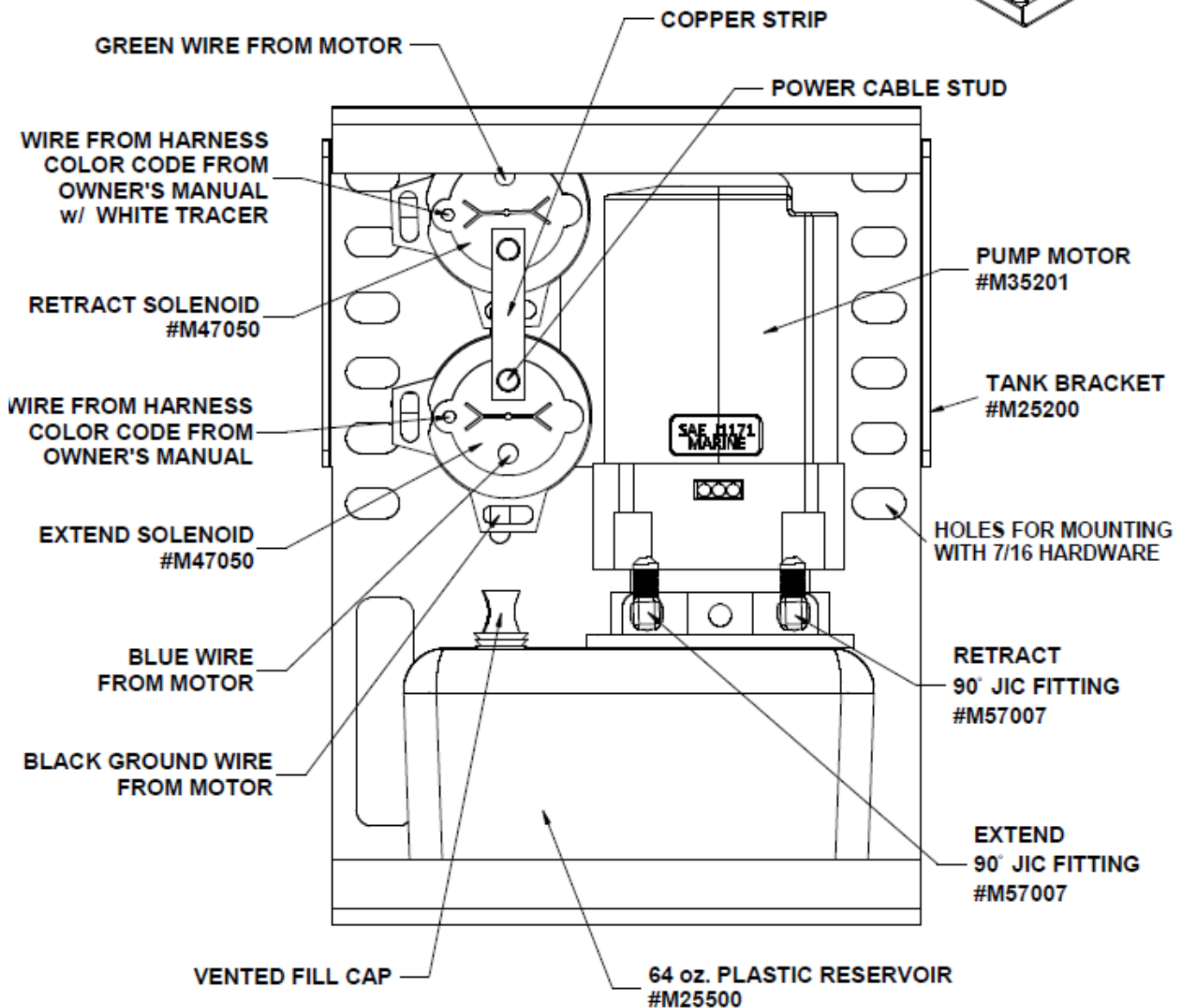

**4 PT WIRING HARNESS COLOR CODE DIAGRAM:**

LEFT FRONT: GREEN/WHITE & GREEN  
RIGHT FRONT: BLUE/WHITE & BLUE  
LEFT REAR: GREY/WHITE & GREY  
RIGHT REAR: BROWN/WHITE & BROWN

**NOT PICTURED:**

TANK COVER  
(BLACK TEXTURED PLASTIC)  
#M12002

## Wiring Instructions

**Installing the breaker:** The system will utilize the trailer’s house batteries not the vehicle battery. Install the 120 amp breaker in-line somewhere between the jack and the battery, usually in battery box.

**Hooking up the breaker:** Attach the corners of the supplied battery cable harness to each tank assembly’s lower solenoid post (with the copper strip) and route to the lead of the harness to the house batteries. Cut the cable at chosen breaker location to insert the in-line breaker (additional battery lugs are supplied). Attach the one end of the cut cable to the AUX stud on the breaker, attach the other end of the cut cable to the BAT stud on the breaker. The final end attaches to the POSITIVE terminal on the house battery. (DO NOT CONNECT TO THE BATTERY UNTIL THE REST OF THE INSTALLATION IS COMPLETE)

**Installing the main wire harness and the battery cable harness:** The main wire harness will have three wires for each corner: One wire goes to the limit switch (has spade connector) (the limit switch has two wires coming from it, the wire with the eyelet goes to ground, the spade connects to harness). The other two wires (same color except one has a tracer) have female push-on connectors that plug into the operation posts on each solenoid. The battery harness has eyelets at each corner that attaches to the power stud on the lower solenoid (with the copper strip). **See the “Medium Tank Assembly” diagram earlier in the booklet.**

The main harness lead has a 14-pin connector at the end, this end will need to route to the sensor location (typically front compartment). Attach the wire harness to the frame rail (usually inside of driver’s side rail with other wiring) with p-clips or zip ties safely routing away from any moving suspension parts or exhaust (complying RVIA regulations).

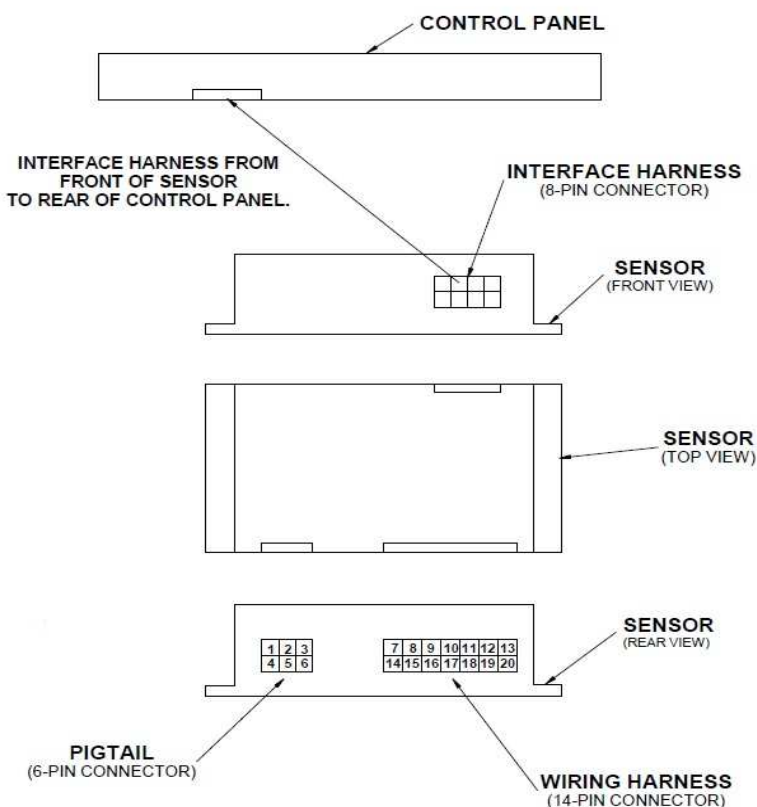

**Installing the Sensor & Panel:** Position in a weatherproof area and fasten the sensor to a secure structure (provided sensor bracket) ensure that it is mounted level and the arrow on top of the sensor is facing the correct way. Typical location of the sensor is in the front main compartment near the front jacks. Plug the 14-pin & 6-pin from the harnesses into the back side. The 6-pin connector only has two wires that need to be hooked up: red and black. The red wire needs to attach to the supplied toggle switch to allow power shut-off, the other end to a fused 12V power source (7.5 amp fuse). The toggle switch is only required for the Gen2 system, and should be placed near the panel for easy access. The black wire is ground. After doing so attach the interface harness (8-pin connector) to the front of the sensor and attach to the control panel. The control panel

may be mounted in an access panel or in a safe location such as a panel somewhere inside the coach, or inside Quadra’s optional plastic box assembly with the harness loosely coiled in a weatherproof storage box.

## **Final Step... Bleed the System!**

Make sure to fill the reservoirs with Dexron III ATF up to  $\frac{3}{4}$ " from the top. Do not completely fill or overfill. All that is required on "quad pump" systems is to enter "Manual mode" on your panel, Run all four jacks to full extension (you will hear the pumps whine), leave the system for 15 to 30 minutes, then retract the system. Do not run one jack to full extension and then move to the other, you need to "walk" the jacks up by lifting in pairs, and working back and forth taking care not to damage your trailer by twisting the frame.

## **Troubleshooting**

If your **ALL UP** light is not coming on and you hear the **buzzing sound from your panel** it might be a limit switch on one of the jacks. Sometimes all you have to do is get a "vacuum cap" for the  $\frac{1}{4}$ " diameter pin to help the limit switch mechanism mate and complete the circuit, if this doesn't work you could have a bad limit switch. Or it could be one of the foot pads are loose, remove  $\frac{3}{4}$ " nut & re-tighten with impact wrench.

If the **LEFT & RIGHT** lights are flashing that means the program "timed out", which may mean the coach is on too un-level ground or there was too much movement in the coach during the automatic leveling program. Try again.

If rear jacks are hanging too low to the ground with the jacks retracted fully, check underneath the coach and check to see if the jack can slide up one row of holes. If this can be done, make sure you raise both rear jacks the same height and tighten each mounting bolt to 70 ft/lbs. If your coach is equipped with an airbag system, just increase air pressure slightly to raise the coach.

---

### **What Hydraulic Fluid do I use?**

Automatic Transmission Fluid (ATF): Dexron II, Dexron III, ATF+4, Mercon, Mercon V

---

### **Panel won't turn on, system won't run, clicking noise, FRONT & REAR lights flash...**

Battery low, panel won't turn on = coach battery, the system relies on the house battery. The battery needs to be nearly 100% charged for the system to work, it doesn't make a difference if the coach is new, that doesn't mean the battery is fully charged or even good. Battery's don't charge instantaneously, so one can't just expect to hook it up to a charger and the system will work immediately, if the battery is good, then the unit might have a ground issue.

**Must un-plug/re-plug the interface cable to clear code on panel regardless.**

---

### **Cylinders won't retract...**

Broken/crushed limit switches, bent or broken clevis pins (especially rear jacks on fifth wheel)

Limit Switch barrels mounted too low, 1" is bad, 1  $\frac{1}{8}$ " is good (Manufacturing defect).

Need new Limit Switches, Clevis pins & Limit Switch Washers (one of each per cylinder).

---

**Cylinders "creep" down when not in use...** Check fluid level, OR Bleed the system, OR Pump valve failure.

**Cylinders make loud "squeaking" noise while operating...** Spray rams with Teflon spray (or dry lubricant).

**Hydraulic Fluid on footpad or on ground around cylinder...** Loose fitting or broken hydraulic line.

**Cylinders "creep" down or don't hold pressure when lifting/holding coach...**

- Check fluid level, Check for leaks in hydraulic lines/fittings...
- Possibly plumbed backwards... (Bottom port on cylinder tube connects to right port on pump, etc.)
- Relief Valves have failed on pump motor... replace motor/tank assembly
- Hydraulic seal failure, check for oil around bottom of cylinder... replace/return cylinder OR seal kit

**Right Front jack not working properly...** Check blue wire connection at 14-pin connector from the harness to sensor.

# Warranty Guide

**4-6pt Automatic Quad Pump Systems:** Lifetime Cylinders, 2 years parts and 1 year labor.

**1pt & 2pt Round Leg Stabilizing/Landing Gear Systems:** 2 years parts and labor.

Should the product be defective due to workmanship and/or material flaws, we will repair/replace the defective material. **Core charges may be applied and refunded on certain components.**

## **Quadra is NOT responsible for:**

- **Freight on warranty parts.**
- **Replacing footpads, bolts, or fluids lost as a result of failure to maintain the system (Loose footpads should be tightened at owner's expense).**
- **Damages caused by abuse, misuse, negligence, misapplication, error of operation, accidental or purposeful damage or faulty installation. Including but limited to hoses, fittings & wiring components.**
- **Liability for loss to the vehicle, or apparatus or property, loss of time, manufacturing costs, labor, material, loss of profits, consequential damages (direct or indirect).**
- **For transportation to and from a service center, onsite service calls to or from the customer, damage from road hazard, loss of salaries, commissions, lodging, towing charges, bus fares, car rentals, fuel expense, telephone charges, inconvenience compensation while repairing or replacing a defective part or material.**

This warranty voids all previous issues. Effective date: 7/1/15

**OWNERSHIP MUST BE REGISTERED WITHIN 30 DAYS FROM THE DATE OF PURCHASE TO  
ACTIVATE WARRANTY. Do it online at [BIGFOOTLEVELER.com](http://BIGFOOTLEVELER.com)!**

Prior to any work being done an **authorization number must be obtained** by calling 269-483-9633 for Warranty Parts or Service Labor. For full warranty transcript just contact us!

Service labor based on a flat rate schedule determined by Quadra for **authorized** work performed will be reimbursed. This will eliminate much diagnostic time and avoid **refusal of unauthorized claims**. Many problems may be resolved by contacting a Quadra service representative.

**Provide the system serial number here \_\_\_\_\_.**

## **Emergency Service**

Visit our website at [bigfootleveler.com](http://bigfootleveler.com)

Or call our normal office number

**269-483-9633** and follow the instructions.