



WCRA

Western
Canadian Reining
Association

2017

High Point Rule Book

www.wcra.info

WCRA

President: Amanda Self

(250) 804-1723

amanda.j.self@gmail.com

Vice President:

Selina Staples

(250) 299-7196

slaffer00@gmail.com

Secretary: Amber Nustad

(250) 392-6402

anustad@gmail.com

Treasurer: Theresa Tremeer

(250) 517-7023

ttremeer60@gmail.com

DIRECTORS AT LARGE

Vancouver Island:

Wilma Yule

Lower Mainland:

Wendy Cassel

Interior:

Amanda Self

Cariboo Region:

Amber Nustad

Youth:

Wendy Cassel as

Adult Rep.

Table of Contents

	<u>Pages</u>
Purpose	3
High Point Show Criteria	3
Year-End High Point Awards	4
Point Tabulation	5
Funding	5
General Conditions	5 - 6
Class Conditions & Eligibility	6 - 8
Judges	8
Beginner Classes	8
WCRA Beginner Pattern A	9
WCRA Beginner Pattern B	10
Modified NRHA Patterns	11 - 14

WESTERN CANADIAN REINING ASSOCIATION 2017 HIGH POINT RULE BOOK

1. PURPOSE

- 1.1 WCRA aims to
- encourage participation at entry level as well as advanced;
 - give riders at all levels the opportunity to fulfill their goals and enjoy the fun of competition;
 - bring the sport of reining into the public eye;
 - promote the welfare of our reining horses.

2. HIGH POINT SHOW CRITERIA

- 2.1 WCRA may designate as a High Point Show any show that meets the criteria set out in this Rule Book and is hosted by a WCRA chapter.
- 2.2 A High Point Show must offer all of the following classes:
- **Ancillary Reining Classes:**
Beginner A, Beginner B, Beginner NRHA Pattern, WCRA Beginner Horse Open, WCRA Beginner Reiner Open
 - **Reining Classes:**
Open, Limited Open, Non Pro, Limited Non Pro, Novice Horse Open (Level 2), Novice Horse Non Pro (Level 2), Rookie (Level 2), Youth, Freestyle.
- 2.3 A WCRA High Point Show must follow the standardized WCRA format for all approved High Point Classes.
- 2.4 WCRA must receive application for High Point Show dates from Chapters by January 1st of the year of the show or, in exceptional circumstances, at least 60 days before the show date. Show approval applications must be received by March 15th. Show dates will be published on the WCRA website.
- 2.5 As far as possible, the rules for High Point Shows will accord with NRHA rules and this WCRA High Point Rule Book. In the event of a conflict in non NRHA-approved classes, WCRA Rules take precedence.

3. YEAR-END HIGH POINT AWARDS

- 3.1 WCRA High Point Awards will be determined by point tabulation from all WCRA High Point shows during the year.
- 3.2 The WCRA point year begins with the first WCRA High Point Show in a calendar year, and ends with the last WCRA High Point show in that year.
- 3.3 **Both** rider and owner must be a WCRA member or, if a non-resident of Canada, must hold a Non-Resident Show Pass to be eligible to collect points towards a High Point award.
- 3.4 A horse/rider combination must enter and compete in **ALL** WCRA High Point Shows in the current year to qualify for a High Point Award.
- 3.5 High Point Awards will be awarded to the High Point Champion and Reserve Champion in each of the following classes:
■**Ancillary Reining Classes:** Beginner A, Beginner B, Beginner NRHA Pattern, WCRA Beginner Horse Open, WCRA Beginner Reiner Open ■**Reining Classes:** Open, Limited Open, Non Pro, Limited Non Pro, Novice Horse Open (Level 2)*, Novice Horse Non Pro (Level 2), Rookie (Level 2)*, Youth, Freestyle.*equivalent to NRHA level 2 classes
- 3.6 In the case of a tie for High Point Champion or Reserve Champion, the entry with the highest single score in that class during the year at a WCRA High Point Show will be High Point Champion or Reserve Champion and the other will move into the next position. If there still is a tie, co-Champions or co-Reserve Champions will be declared.
- 3.7 High Point Awards will be presented to the registered owner of the horse at the year end awards banquet, and will be equal in value for each class, split 70% Champion (including co-Champions), and 30% Reserve Champion (including co-Reserve Champions).
- 3.8 A winner of more than one High Point award in a year may choose to receive the cash value of the awards, less the cost of a commemorative plaque, to apply to the purchase of show gear.

4. POINT TABULATION

- 4.1 Points will be tabulated according to the NRHA Affiliate point system.
- 4.2 Points will be tabulated on each horse/rider combination.
- 4.3 Show must be submitted to the WCRA High Point Secretary within 14 days of the competition. Failure to do so may cause the Executive to take disciplinary action.
- 4.4 The WCRA High Point Secretary will keep the official record of points.
- 4.5 High Point standings will be published regularly on the WCRA website.

5. FUNDING

- 5.1 High Point Awards will be funded by increasing the fees in High Point classes by \$5.00 for each horse/rider combination in that class.
- 5.2 These funds will be forwarded to WCRA and will be deposited to a separate High Point Award account.

6. GENERAL CONDITIONS

- 6.1 Both owners and riders competing in WCRA approved events must be HCBC members; or if a non-resident of B.C., must show proof of insurance coverage.
- 6.2 WCRA-approved shows are open to all breeds, grade horses, ponies, and mules (referred to in these rules as horses). Proof of ownership is required for all horses (registration papers, bill of sale, etc.).
- 6.3 All non-modified reining patterns (NRHA patterns 1 thru 13) will be judged according to the current NRHA Rule Book.
- 6.4 All beginner classes using WCRA modified patterns) will be judged according to the current NRHA Rule Book as modified by WCRA criteria.
- 6.5 Payouts, when applicable, will be paid to the horse owner of record according to the current NRHA Rule Book payout schedule.
- 6.6 Scores will be posted as per current NRHA Rule Book.

- 6.7 An owner may enter more than one horse and a rider may ride more than one horse. A rider may not show more than three horses in a class (as per current NRHA Rule Book).
- 6.8 A horse may be entered only once per class.
- 6.9 There will be at least two works between double-entered riders, if possible.
- 6.10 It is the responsibility of the owner and rider to be aware of his or her official earnings; and riders will be required to sign a declaration of eligibility.
- 6.11 NRHA rules for judging will apply to all classes, with exceptions as noted.
- 6.12 NRHA rules for legal headgear will apply to all classes, with exceptions as noted.
- 6.13 The following classes may not be jackpot classes: Open, Limited Open, Non Pro.
- 6.14 At all High Point approved shows there will be no entry refunds, but substitutions of horses will be allowed with a vet certificate, or riders with a doctor's note.

7. CLASS CONDITIONS & ELIGIBILITY

- 7.1 **Beginner A:** May be ridden 1 or 2 handed; running martingale optional (must be outfitted with rein stoppers); NRHA legal headgear; modified pattern with no lead changes. Restricted to riders who:
- meet the Non Pro criteria as set out in the current NRHA Rule Book,
 - have not competed in a class that required a non-modified NRHA pattern (NRHA patterns 1 thru 10) to be ridden one-handed youth class exempted,
 - have not won a High Point Championship or Reserve Championship in Beginner A, Beginner B, Beginner NRHA Pattern, Youth, or Beginner Reiner Open, and
 - have not ridden a horse to a Championship or Reserve Championship in Beginner Horse Open.
- 7.2 **Beginner B:** May be ridden 1 or 2 handed; running martingale optional (must be outfitted with rein stoppers); NRHA legal headgear; modified pattern with no lead changes. Restricted to riders who:
- meet the Non Pro criteria as set out in the

- current NRHA Rule Book,
 - have not competed in a class that required a non-modified NRHA pattern (NRHA patterns 1 thru 13) to be ridden one-handed youth class exempted,
 - have not won a High Point Championship or Reserve Championship in Beginner B, Beginner NRHA Pattern, Youth, or Beginner Reiner Open, and
 - have not ridden a horse to a Championship or Reserve Championship in Beginner Horse Open.
- 7.3 **Beginner NRHA Pattern:** May be ridden 1 or 2 handed; any NRHA approved headgear; no running martingale. Restricted to riders who:
 - meet the Non Pro criteria as set out in the current NRHA Rule Book,
 - have never placed 1st, prior to the current year, in a class that required a non-modified NRHA pattern (NRHA patterns 1 thru 13) to be ridden one-handed, and
 - have not won a High Point Championship or Reserve Championship in Beginner NRHA Pattern.
- 7.4 **Beginner Horse Open:** NRHA Pattern 1 through 13; may be ridden 1 or 2 handed; any NRHA-approved headgear; no running martingale. Restricted to horses with less than \$500 lifetime earnings in reining competitions at the start of the year.
- 7.5 **Beginner Reiner Open:** Modified patterns 4, 5, 6, or 8 (containing no lead changes); may be ridden 1 or 2 handed; any NRHA approved headgear; no running martingale. Restricted to riders with less than \$500 lifetime winnings in reining competitions at the start of the year.
- 7.6 **Novice Horse Open (1 & 2):** Current NRHA rules;
- 7.7 **Novice Horse Non Pro (1 & 2):** Current NRHA rules.
- 7.8 **Rookie (1 & 2):** Current NRHA rules.
- 7.9 **Youth:** Current NRHA rules (except for age categories--WCRA youth class is 18 & under).
- 7.10 **Limited Non Pro:** Current NRHA rules
- 7.11 **Non Pro:** Current NRHA rules.

7.12 **Limited Open:** Current NRHA rules.

7.13 **Open:** Current NRHA rules.

7.14 **Freestyle:** Current NRHA rules.

8. JUDGES

8.1 WCRA High Point Reining Shows must be judged by an NRHA Judge.

9. BEGINNER CLASSES-REQUIRED MANEUVERS

9.1 WCRA Beginner A:

Required maneuvers are:

- two large fast circles and one small slow circle to the left,
- two large fast circles and one small slow circle to the right;
- Four spins left and right;
- one rollback;
- two** stops;
- one back up.

Show committees must draw a pattern using only these maneuvers and post it one hour before running the class.

9.2 WCRA Beginner B & Beginner Reiner Open:

Required maneuvers are:

- two large fast circles and one small slow circle to the left;
- two large fast circles and one small slow circle to the right;
- two rollbacks;
- three stops;
- four spins left and right;
- one back up.

Show committees must draw a pattern using only these maneuvers and post it one hour before running the class.

9.3 WCRA Beginner NRHA Pattern:

Any NRHA pattern.

WCRA Beginner Pattern A

1. Beginning at the center of the arena face the left wall or fence.
2. Complete four spins to the right. Hesitate.
3. Beginning on the right lead, complete three circles to the right: The first two large and fast, the third circle small and slow. Stop at the center of the arena.
4. Complete four spins to the left. Hesitate.
5. Beginning on the left lead, complete three circles to the left: The first two large and fast, the third circle small and slow. Stop at the center of the arena.
6. Beginning on the right lead, begin a large circle to the right, do not close this circle, but run straight down the right side of the arena, staying at least 20 feet (6 metres) from the wall or fence, past the center marker and do a left roll back.
7. Continue around previous circle. Run down the right side of the arena, staying at least 20 feet from the wall or fence, past the center marker, stop and back up at least 10 feet. (3 metres)
8. **Rider must dismount and drop bridle to the designated judge.**

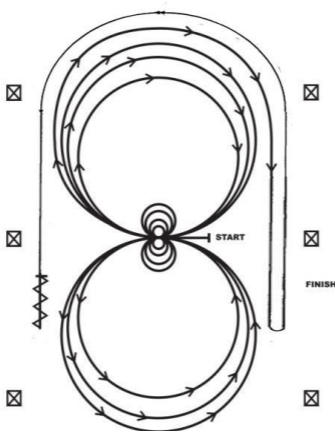

WCRA Beginner Pattern B

Beginning at the center of the arena face the left wall or fence.

1. Beginning on the right lead, complete three circles to the right: The first two large and fast, the third circle small slow. Stop at the center of the arena.
2. Beginning on the left lead, complete three circles to the left: The first two large and fast, the third circle small and slow. Stop at the center of the arena.
3. Complete four spins to the left. Hesitate.
4. Complete four spins to the right. Hesitate.
5. Begin a large circle to the right, but do not close this circle, run down the right side of the arena, past the center marker, staying at least 20 feet from the wall or fence and do a left roll back.
6. Continue around previous circle to the left. Run down the left side of the arena, past the center marker, staying at least 20 feet from the wall or fence, and do a right roll back.
7. Continue around previous circle. Run down the right side of the arena, staying at least 20 feet from the wall or fence, past the center marker, stop and back up at least 10 feet.
8. Hesitate to demonstrate completion of the pattern.
9. **Rider must dismount and drop bridle to the designated judge.**

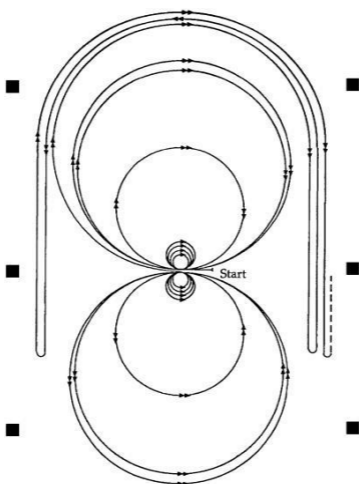

Beginner Reiner Open

Class must be run with one of four modified NRHA patterns (Modified 4, Modified 5, Modified 6 & Modified 8)

WCRA – NRHA Pattern 4 Modified:

Horses may walk or trot to the center of the arena. Horses must walk or stop prior to starting pattern. Beginning at the center of the arena facing the left wall or fence.

1. Beginning on the right lead, complete three circles to the right: the first two large and fast; the third small and slow. Stop at the center of the arena. Hesitate.
2. Complete four spins to the right. Hesitate.
3. Beginning on the left lead, complete three circles to the left: the first two large and fast; the third small and slow. Stop at the center of the arena. Hesitate.
4. Complete four spins to the left. Hesitate.
5. Beginning on the right lead, begin a large fast circle to the right but do not close this circle. At the top of the circle, run down the middle to the far end of the arena past the end marker and do a right rollback - no hesitation.
6. Run up the middle to the opposite end of the arena past the end marker and do a left rollback - no hesitation.
7. Run past the center marker and do a sliding stop. Back up to the center of the arena or at least ten feet (three metres). Hesitate to demonstrate completion of the pattern.
- 8. Rider must dismount and drop bridle to the designated judge.**

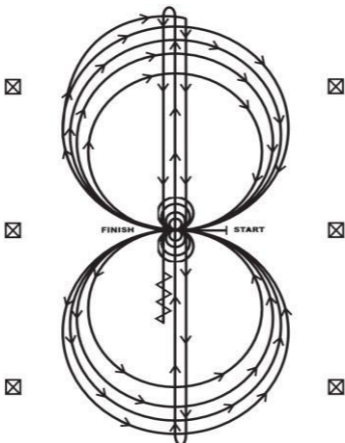

Beginner Reiner Open

WCRA – NRHA Pattern 5 Modified:

Horse may walk or trot to the centre of arena.

Horses must walk or stop prior to starting pattern.

Beginning at the centre of the arena facing the left wall or fence.

1. Beginning on the left lead, complete three circles to the left: the first two circles large and fast; the third circle small and slow. Stop at the centre of the arena. Hesitate.
2. Complete four spins to the left. Hesitate.
3. Beginning on the right lead, complete three circles to the right; the first two circles large and fast; the third circle small and slow. Stop at the centre of the arena. Hesitate.
4. Complete four spins to the right. Hesitate.
5. Begin on the left lead and run a large fast circle to the left but do not close this circle. Run up the right side of the arena past the centre marker and do a right rollback at least twenty feet (six metres) from the wall or fence - no hesitation.
6. Continue around the previous circle but do not close this circle. Run up the left side of the arena past the centre marker and do a left rollback at least twenty feet (six metres) from the wall or fence - no hesitation.
7. Continue back around previous circle but do not close this circle. Run up the right side of the arena past the centre marker and do a sliding stop at least twenty feet (six metres) from the wall or fence. Back up at least ten feet (three metres). Hesitate to demonstrate completion of pattern.
8. **Rider must dismount and drop bridle to the designated judge.**

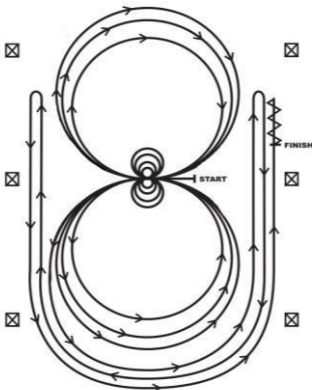

Beginner Reiner Open

WCRA – NRHA Pattern 6 Modified:

Horses may walk or trot to centre of arena.

Horses must walk or stop prior to starting pattern.

Beginning at the centre of the arena facing the left wall or fence.

1. Complete four spins to the right. Hesitate.
2. Complete four spins to the left. Hesitate.
3. Beginning on the left lead, complete three circles to the left: the first two large and fast; the third circle small and slow. Stop at the centre of the arena. Hesitate.
4. Beginning on the right lead, complete three circles to the right: the first two circles large and fast; the third circle small and slow. Stop at the centre of the arena. Hesitate.
5. Beginning on the left lead, run a large fast circle to the left but do not close this circle. Run up the right side of the arena past the centre marker and do a right rollback at least twenty feet (six metres) from the wall or fence - no hesitation.
6. Continue back around the previous circle but do not close this circle. Run up the left side of the arena past the centre marker and do a left rollback at least twenty feet (six metres) from the wall or fence - no hesitation.
7. Continue back around the previous circle but do not close this circle. Run up the right side of the arena past the centre marker and do a sliding stop at least twenty feet (six metres) from the wall or fence. Back up at least ten feet (three metres). Hesitate to demonstrate completion of pattern.
- 8. Rider must dismount and drop bridle to the designated judge.**

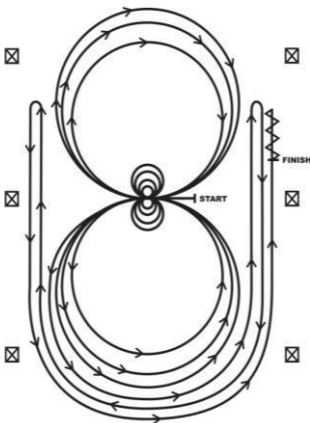

Beginner Reiner Open

WCRA – NRHA Pattern 8 Modified:

Horses may walk or trot to centre of arena.

Horses must walk or stop prior to starting pattern.

Beginning at centre of arena facing left wall or fence.

1. Complete four spins to the left. Hesitate.
2. Complete four spins to the right. Hesitate.
3. Beginning on the right lead, complete three circles to the right: the first circle large and fast; the second circle small and slow; the third circle large and fast. Stop at the centre of the arena. Hesitate.
4. Beginning on the left lead, complete three circles to the left: the first circle large and fast; the second circle small and slow; the third circle large and fast. Stop at the centre of the arena. Hesitate.
5. Beginning on the right lead, run a large fast circle to the right but do not close this circle. Run straight down the right side of the arena past the centre marker and do a left rollback at least twenty feet (six metres) from the wall or fence - no hesitation.
6. Continue back around the previous circle but do not close this circle. Run down the left side of the arena past the centre marker and do a right rollback at least twenty feet (six metres) from the wall or fence - no hesitation.
7. Continue back around the previous circle but do not close this circle. Run down the right side of the arena past the centre marker and do a sliding stop at least twenty feet (six metres) from the wall or fence. Back up at least ten feet (three metres). Hesitate to demonstrate completion of the pattern.
8. **Rider must dismount and drop bridle to the designated judge.**

