

PRODUCT DATASHEET

HFW-BSB-01

WIRELESS SOUNDER BASE/VISUAL INDICATOR

The HFW-BSB-01 Wireless Sounder Base with Visual Indicator unit is an aesthetically pleasing and cost effective alternative to traditional wall mounted units where visual impact is important. Each unit has an integral moulded base for mounting a Hyfire wireless detector or a sounder cover if a detector is not required. The unit has as standard 32 recognised sounder tones and 3 levels of volume adjustment, all of which can be easily configured on site. Additional to the audible warning the unit is also fitted with a LED visual indicator for added warning capability. Utilising well-proven adaptive radio signal processing algorithms ensures the highest levels of life safety and reliability.



KEY FEATURES

- 3rd party Approval to EN54-25 and EN54-03
- Bi-directional wireless communication
- 5 year product warranty
- Utilises dual low cost standard lithium batteries
- Choice of 32 recognised tones
- Compatible with all Hyfire translators and expanders
- Additional LED visual indicator
- Red and white cover options
- 3 volume levels
- 3 year expected battery life

TECHNICAL INFORMATION

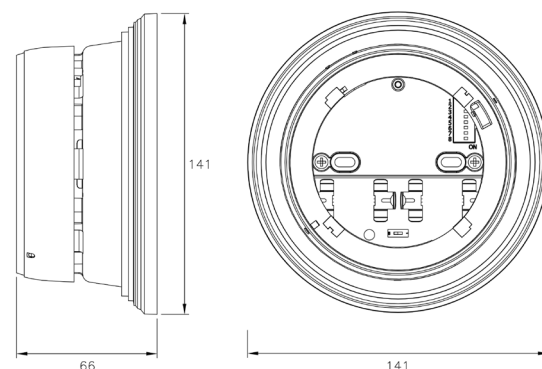

TECHNICAL SPECIFICATION

- | | |
|--|----------------------------------|
| ■ Operating frequency range | 868 - 870 MHz |
| ■ Operating frequency channels | 7 |
| ■ Communication range with the Translator or Expander Module | ≤ 150m (in open space) |
| ■ IP rating | 21C (Type A for indoor use only) |
| ■ Sound Output (typical) | 70-95dBA (tone dependant) |
| ■ Number of Tones | 32 |
| ■ Visual Indicator frequency | 1Hz |
| ■ Dimensions | 141 mm x 66 mm |
| ■ Weight (without batteries) | 260g |
| ■ Primary battery | CR123A (3 V & 1.2 Ah) |
| ■ Secondary battery | CR123A (3 V & 1.2 Ah) |
| ■ Primary battery lifespan (typical) | ≥ 3 years |
| ■ Backup at low battery (typical) | ≥ 2 months |
| ■ Operating Temperature | -10°C to +55°C |
| ■ Max humidity (non condensing) | 95% RH |

STANDARDS & APPROVALS

- BS EN 54-25:
Components using radio links and system requirements
- BS EN 54-3:
Fire alarm devices - Sounders



0832



928q