

Turbo air
AIR CONDITIONER MANUFACTURER

4184 E. Conant St.
Long Beach, CA 90808
Tel. 888-900-1002
Fax. 310-900-1088
www.turboairinc.net

Project :

Model # :

Item # :

Qty :

Approval :

Condensing Unit

Model : TH010LR404A2-T



≡ FEATURES / BENEFITS ≡

- Blue anti-corrosion-fin increases the life span of the coil.
- Seamless inner groove copper tube increases the heat exchange rate by reducing the space between the fin and copper tube.
- Highest quality compressor in the world.

- Head pressure control stabilizes the freezing of liquid line, minimizes formation of flash gas to increase efficiency of the system, and prevents compressor damage by controlling high pressure.
- Experienced engineers have designed the system for maximum efficiency.
- Fan Blades : Specifically matched with motors and coil for maximum air movement and cooling.
- Control box is designed for easy installation.
- Low pressure control is adjustable.
- All the parts are compliant with industry standards and interchangeable with readily available parts.
- Wiring : Easily accessible. Compressor comes with a wiring harness that is manufactured with connections that will not come loose with vibration.
- Control box and service valves are located outside for easy service.
- Base : Heavy duty steel. Legs are 2-1/6" tall
- Cabinet : Prepainted with galvanized body. Protects against corrosion.
- All products carry UL, cUL, ISO 9001 approvals.

Condensing Unit

Model : TH010LR404A2-T

PERFORMANCE CHART

	40°F(SST)	30°F	25°F	20°F	0°F	-10°F	-20°F	-25°F
90°F(AMBIENT)	-	-	8591	8018	5750	4686	3699	3244
95°F	-	-	8278	7717	5497	4461	3503	3061
100°F	-	-	7965	7416	5245	4237	3307	2878
110°F	-	-	7339	6814	4741	3788	2915	2513

SPECIFICATION

	TH010LR404A2-T
Compressor	CAJ2446Z
Line Size	3/8" Liquid 1/2" Suction
Receiver 90%	6
Fan Data	1Fan(980CFM)
Dimensions	28.27(D) x 24.49(W) x 17.87(H)
Net Weight	148.3 Lbs
Power Supply	208-230/1ph/60hz
Compressor Amp	4.8
MCA	15
MOPD	15

Design and specifications subject to change without notice

- **WARRANTY :** 1 Year Compressor Warranty (4 Year extended warranty available)
1 Year Fan Motor and Parts Warranty

(unit : inch)

PLAN VIEW

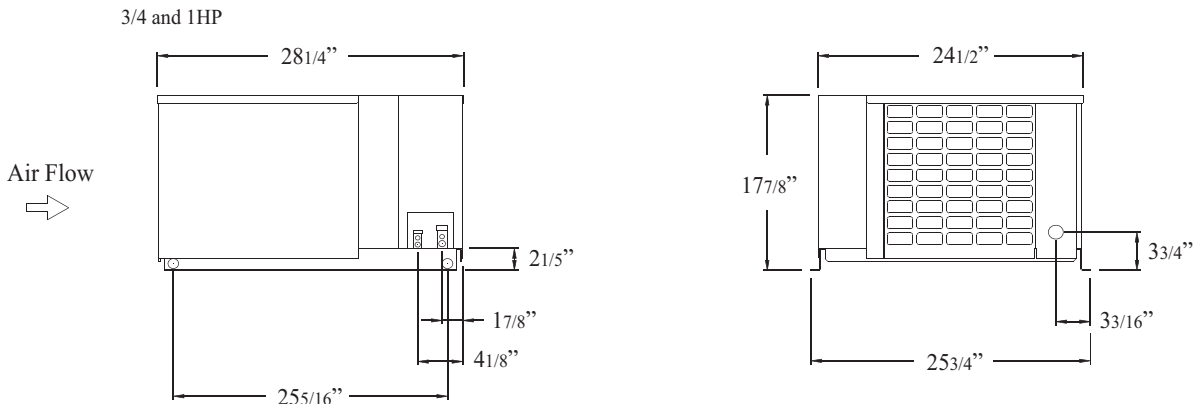

■ Toll Free : 888-900-1002

REFRIGERATOR MANUFACTURER
Turbo air

GERMAN KNIFE

RADIANCE

GREEN WORLD

AIR CONDITIONER MANUFACTURER
Turbo air