

ZTS/ZTTS

Shredder For Car Tires

- Single large diameter rotor (750 mm)
- Proprietary knife design and material
- Variable knife gap to improve separation of steel and rubber
- Compact Heavy Duty design
- High throughput rates
- Fast and easy tool change and maintenance



The ZERMA tire shredders use special highly wear resistant tungsten carbide flat knives. These knives ensure a long lifetime of working with abrasive and contaminated materials.



The ZTS and ZTTS shredders are equipped with large diameter flat rotors with weld on hard facing. The knives are fixed in special knife holders fitted in machined pockets.



The oversized gearbox driving the rotor is supported by a very sturdy torque arm cushioning the shocks created while grinding.

General Description

The ZTS and ZTTS single shaft shredders are specially designed for the processing of complete or pre-shred tires. Both machines feature a 750 mm diameter rotor with width options 1500mm to 3000 mm with oversized outboard bearings and twin gear drives. The tangential infeed ensures optimal feeding of the input materials while eliminating the need for a hydraulic feeding system. All tire shredders are equipped with a complete wear package including rotor hard facing plus special knives and wear plates made from highly wear resistant steel. The ZTS and ZTTS differ in the number of stator knives and the screen sizes used. The modular design makes it easy to integrate either machine into existing installations.

Applications

The ZTS with its single row of stator knives is used to pre shred complete car tires or large pieces of pre processed truck tires down to a size of approx 150 mm. The twin rows of stator knives and screen in the ZTTS enable it to process the tire shreds down to any required size >20 mm.

> The unique machine design combined with the variable cutting gap create an optimal separation of rubber and steel when the machine is used with 20 mm screen. Therefore, steel can be removed easily during the following process with magnetic separation equipment. The machines are also used in the processing of RDF and other alternative fuel applications.



The Home of Size Reduction

ZTS/ZTTS

Shredder For Car Tires

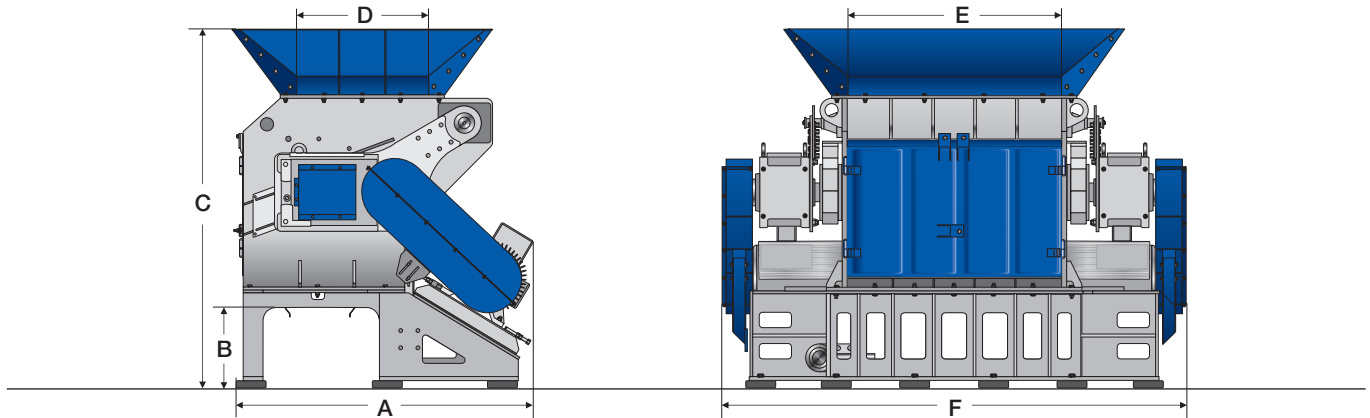

Technical Specifications and Dimensions

Model

Rotor diameter (mm)

Rotor width (mm)

Rotor speed (rpm)

Drive capacity (kW)

Rotor knife (pcs)

Stator blades (rows)

Screen size (mm) ZTS

ZTTS

Effective working area (mm)

Weight approx (kg) ZTS

ZTTS

A (mm)

B (mm)

C (mm)

D (mm)

E (mm)

F (mm)

1500

760

1560

41

2 x 90

76

1 or 2

80mm screen bars

>16

1005 x 1620

12300

12800

2300

605

2700

1000

1620

3800

2000

760

1960

41

2 x 110

96

1 or 2

80mm screen bars

>16

1005 x 2020

15300

16500

2300

605

2700

1000

2020

4240

3000

760

2760

41

on request

136

1 or 2

80mm screen bars

>16

1005 x 2820

20500

21500

2300

605

2700

1000

2820

5040

ZERMA

311 Era Drive

Northbrook, IL 60062

Phone: 1-847-291-1300

sales@zerma-america.com

zerma.com

