

The Zip Dee  
**Evolution**  
Series

**AutoAwn - Automatic Patio Awning**

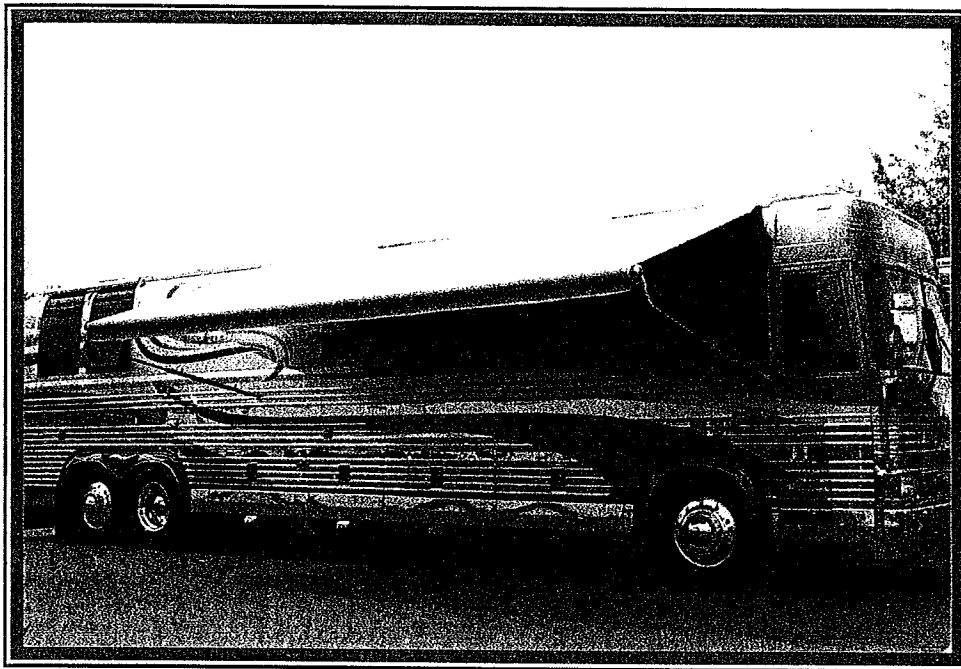

Owner's Manual

24 VDC SYSTEM  
with Wind Sensor

**Awnings By Zip Dee, Inc.**  
96 Crossen Ave.  
Elk Grove Village, IL 60007  
847/437-0980 800/338-2378  
[www.zipdeeinc.com](http://www.zipdeeinc.com)

This Product is protected by  
U.S. Patent 5,597,006; 5,823,216  
and others pending

# Congratulations!

You now own the most technically advanced awning made in America: the Zip Dee **AutoAwn™** - the first R.V. awning you can open or close with just the touch of a button!

The **AutoAwn™** is the product of over four years of intensive, dedicated research. It's the kind of industry-leading innovation you expect from Zip Dee - the company that introduced the spring-powered roll-up awning in 1965.

**Before you begin to use your AutoAwn™, please take time to read this manual.** It contains information about how the awning works and how to avoid problems when operating it. For help in solving a particular problem, turn to the "Trouble-Shooting" section. Throughout the manual, look for the "alert triangle" symbol,  which indicates important safety considerations.

We hope you enjoy your new **AutoAwn™**. For the truly "carefree" R.V. lifestyle, you know you can trust the Zip Dee name!

## Warnings and Cautions



Before operating your awning, **your vehicle battery should be fully charged and your air compressor on and delivering 110 psi minimum.** (See section IV. Troubleshooting for operational limits.)



Always make sure you have enough space in which to open your awning! The **AutoAwn™** extends 8 feet from the side of your vehicle. Even though you can halt the awning opening cycle, you should first check for obstacles.



**Do not stand under your awning while it is opening or allow anyone else to do so.** Wait until it is fully extended and locked in position before moving underneath it.



**Do not adjust or modify anything in the AutoAwn™ control box!** These devices have been factory set for proper operation. Unauthorized changes could void the Zip Dee or vehicle warranty, damage your awning or even cause injury to someone. **Do not attempt to operate or adjust the awning or controls except as directed in the owner's manual or installation instructions!**

# TABLE OF CONTENTS

I.	Components Included with Your AutoAwn™ .....	4
II.	Awning Operation .....	5
	Opening the Awning .....	5
	Partial Extension .....	6
	Closing the Awning .....	6
	Weather Precautions .....	6
	At Night or When Leaving Your Vehicle .....	6
III.	Maintenance .....	7
	Hardware .....	7
	Fabric .....	7
	Control System .....	8
	Long-Term Storage .....	8
	AutoAwn™ Operation Sequence .....	9
	Limited Warranty .....	10
IV.	Appendix A: Motor Adjustments & Emergency Closing	
	Exhibit A: What is in Control Box	

# I. Components Included with Your AutoAwn™

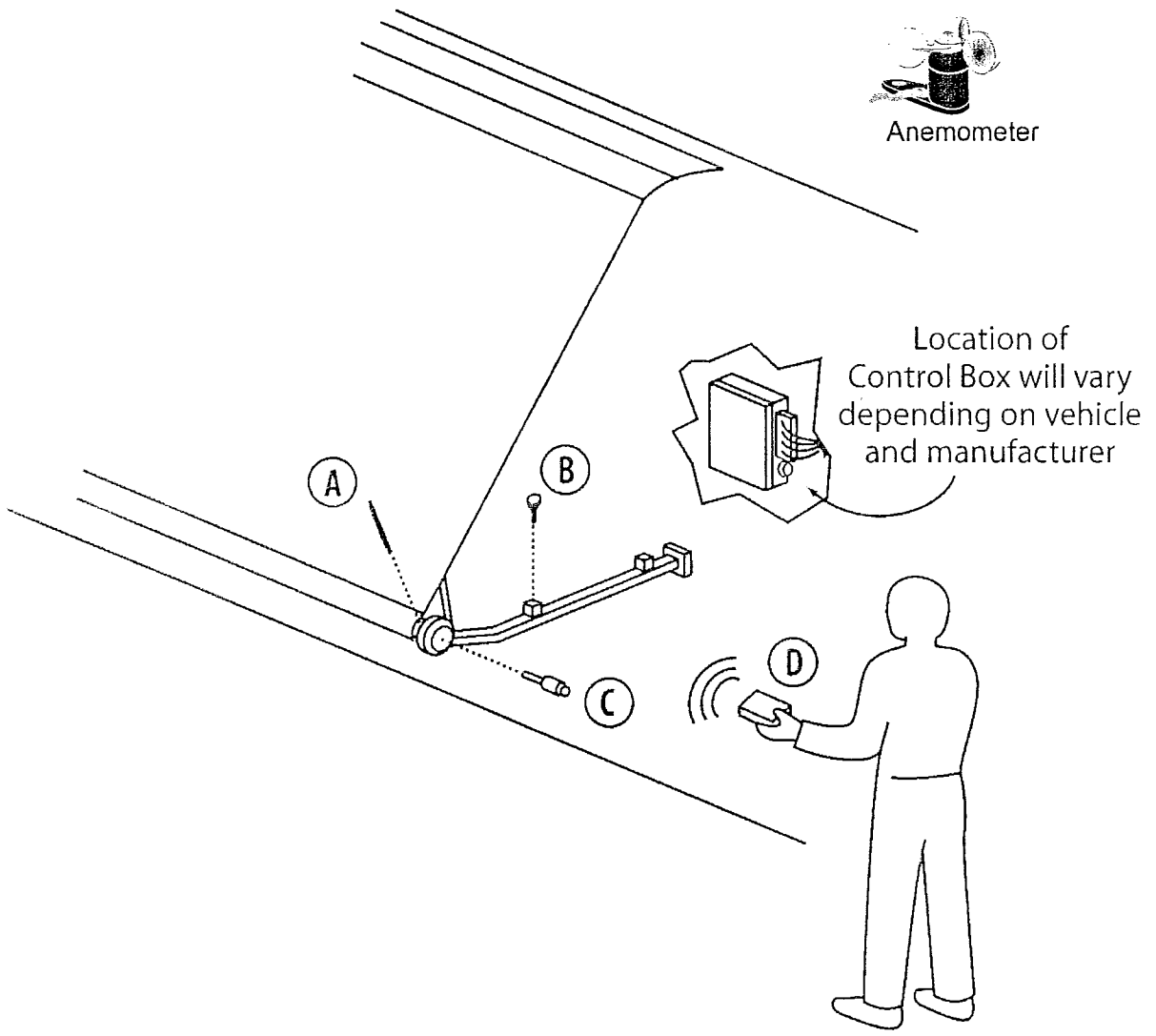



Location of Control Box will vary depending on vehicle and manufacturer

- 

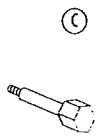
**A**  
Motor Limit Switch Adjusting Hex Key
- 

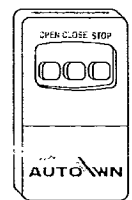
**B**  
Manual Lock Release Knob
- 

**C**  
Combination Winding & Shaft Retention Tool
- 

**D**  
Three-Button Remote Transmitter (Open/Close/Stop)
- 

**E**  
Emergency Power Cord

\* These adjustment tools are located in the "AutoAwn™ Adjustment Tool Kit." They should be stored in the vehicle. The diagram above shows where they are used when needed.

## II. Awning Operation

The Zip Dee AutoAwn™ system allows you to open and close your Zip Dee awning with the touch of a button.

The AutoAwn™ operates via compressed air, a DC electric motor housed in the awning roller, and an electronic program. Opening or closing the awning takes less than one minute; the actual time will vary depending on the strength of your battery.

After one cycle, (one opening and one closing) **you will be unable to operate the awning for 10 minutes.** This built-in delay is necessary to allow your air compressor to cool.

### Opening the Awning

1. Position your vehicle so that the awning has 8 feet of clear space in which to open. Watch for other vehicles, hanging branches, wires, etc.
2. Check that you have sufficient power (11 vdc minimum) and air (90 psi minimum) to operate your awning.
3. Make sure no one is standing in the area where the awning will open.
4. Press and release the OPEN button on the remote transmitter while standing within 4-6 feet of the AutoAwn™ control box. You can also open the awning by momentarily moving the slide switch marked "Awning" (inside the control box) to the "OPEN" position.
5. Be patient. There will be a slight delay as the system pressurizes and begins to operate after signal is received from remote transmitter or box switch.

### Partial Extension

**Press and release the STOP button** on the remote transmitter. This will immediately stop the awning at any position. NOTE: the stop function will not work while the main arms are in the process of extending.

Once the arms are fully extended, the awning can be stopped. From the stopped position, you can either allow it to open fully by momentarily pressing the "OPEN" button or close the awning by momentarily pressing the "CLOSE" button.

## Closing the Awning

1. Look out for hanging branches, wires or other vehicles. Nothing should obstruct the awning as it retracts.
2. Check that you have sufficient power (11 vdc minimum) and air (90 psi minimum) to operate your awning.
3. Make sure no one is standing under the awning.
4. Press and release the CLOSE button on the remote transmitter while standing within 4-6 feet of the control box. You can also close the awning by momentarily moving the slide switch marked "Awning" (inside the control box) to the "CLOSE" position.

## Partial Extension

Press and release the STOP button on the remote transmitter. This will immediately stop the awning in any position, except when the main arms are in the process of retracting.

## Weather Precautions



Although your awning is equipped with a wind sensor (anemometer) that automatically closes your awning in high wind, use discretion and close **the awning if high wind, rain, or snow threaten!** AutoAwn™ is very strong and has been tested in winds over 30 mph, storms can eventually damage any structure. When in doubt, roll it up!

Since the awning can close automatically, **DO NOT ATTACH OBJECTS (OR ANIMALS) TO ANY PART OF THE AWNING.** They can be inadvertently harmed.

## Wind Speed Sensitivity Setting

The anemometer sensitivity adjustment (in the control box) is preset at approximately 27 mph. **DO NOT CHANGE THIS SETTING.** Changing the wind speed setting could void any warranty and **MAY CAUSE DAMAGE** to both the awning and the vehicle.

When the awning is open and the wind speed is greater than 27 mph for more than 2 seconds, the awning will close. As long as the wind speed remains high, all other commands will be ignored. When the wind speed drops below the set value, the controls will return to normal operation.

## At Night or When Leaving Your Vehicle

If you are leaving your vehicle for any length of time or retiring for the night, take a minute to retract the awning. It takes less time than closing your windows and affords you the best protection for your awning and vehicle.

### III. Maintenance



#### Hardware

**Cleaning:** Although your Zip Dee **AutoAwn™** requires less maintenance than any other awning, a little care will keep the metal parts in top shape. The main arm tubes and the awning case are anodized aluminum; the castings are high-strength aluminum alloys. To keep these parts looking new, they should be cleaned once a year with a good quality non-abrasive chrome or aluminum polish.

The rafter tubes, main arm bars, fasteners and stress bearing shafts are all stainless steel. They should be cleaned as needed to remove accumulated grime that might hinder operation. Before cleaning, open the awning to make these parts more accessible. After cleaning, apply a light coat of silicone lubricant or "dry lube" (not WD40) to these areas and wipe off any excess.

**Lubrication:** The main arms require an **annual internal lubrication** applied through the lubrication port in the main arm. See the Appendix A "Adjustment Procedure" for detailed directions.

#### Fabric

**Minimizing Wear and Tear:** Any fabric can be punctured or torn by sharp edges. Be aware of such conditions and protect the fabric from abuse (e.g., install a roller on the outer edge of a door if it rubs the fabric).

**Cleaning:** The beautiful fabric of your Zip Dee **AutoAwn™** is Sunbrella® - made of acrylic fibers which cannot rot or mildew. Your awning can be rolled up wet if necessary, but be sure to open it up to dry as soon as possible.

Acrylic fabric is a synthetic and cannot support mildew or other plant growth. However, mildew can grow on pollen, grain, plant spores, or other airborne organic material, which can accumulate on the awning or in the weave. Mildew that grows on this foreign matter can leave an unsightly stain which, although not harmful to the fabric, can be difficult to remove. To minimize the chance of a stain, keep the awning fabric clean by following the steps below. Don't wait for stains or dirt to become visible.

1. Once a month, loosen hardened dirt and dust with a dry, medium bristle brush. Then thoroughly rinse both top and bottom of the awning with a hose.
2. Seasonally, wash your awning with **Zip Dee WashOut Acrylic Awning Cleaner**. Wash both sides of the awning with the solution while scrubbing with a Zip Dee awning brush. Saturate the fabric and leave the solution on for 15 - 20 minutes. Keep the fabric saturated by reapplying solution as needed. Rinse thoroughly. Repeat, if necessary, until stains disappear.

Never use a strong detergent or stain remover such as 409® or Fantastic® on your awning. These can destroy the water repellency of the fabric.



**Water Leaks:** If leaking occurs after washing, it is usually the result of insufficient rinsing. Rinse as often as needed to remove all solution. If water drips through the needle holes in the stitching, you can use a commercial seam sealer, available in canvas and trailer supply stores. You may also apply paraffin wax to the top of the seams. However, as the awning "weathers," these holes will normally heal themselves.

It is normal for slight leakage to occur through the fabric where water is allowed to accumulate or "pocket" on the fabric. Sometimes soap or chemical residue from insect fogs or sprays can "wet" the fabric so that it appears unable to repel water. Wash the fabric as described above and test for water repellency after it dries. If leakage continues after repeated washing and rinsing, please contact Zip Dee concerning further maintenance.

## Compressor

Periodically drain your air compressor's auxiliary tank (see the instructions for your compressor). Failure to do this will allow water build-up leading to clogged air lines.

## Control box

**Batteries:** Batteries will need to be changed every 2 to 4 years, depending on usage.

**Electrical and pneumatic components:** Do not attempt to perform maintenance on the electrical system of your **AutoAwn™**. Do not adjust or modify anything in the control box. Please contact your vehicle manufacturer or Zip Dee for help with these systems.

## Long-Term Storage

There is a small but constant voltage usage by the control box, even when the awning is not in use. This voltage draw is mostly to maintain the charge in the control box batteries. If the vehicle (and the awning) will be stored or unused for an extended length of time (over one month) with the power to the control box shut off, the batteries may drop in voltage to a point that is insufficient to operate the awning.

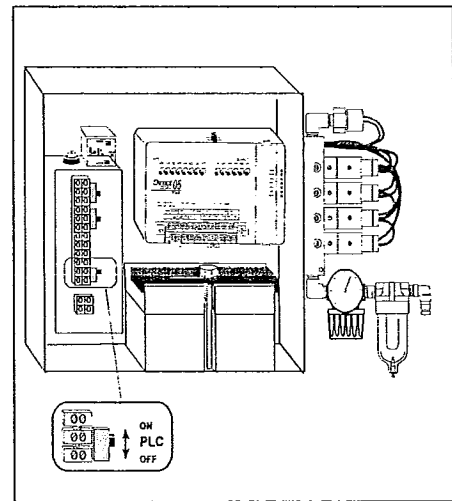

When returning your awning to use, make sure that the "PLC" switch is in the "ON" position. It may take up to 12 hours for the batteries to regain a full charge after the power is reconnected. The awning controls will then respond to either the "OPEN" or "CLOSE" command from the remote transmitter or the slide switch inside the control box.



## Zip Dee AutoAwn Operation Sequence

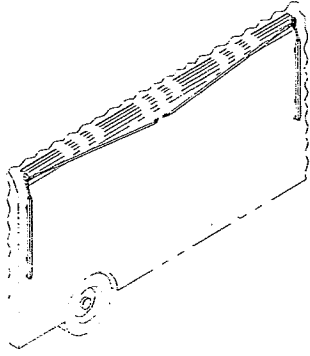

1. Awning Closed.

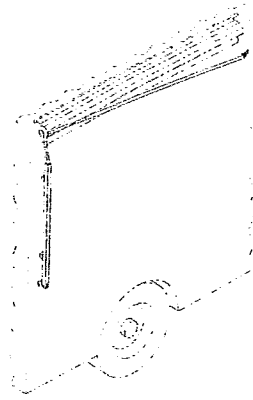

2. Fabric begins to unroll.



3. Push-off moves arm from vehicle.

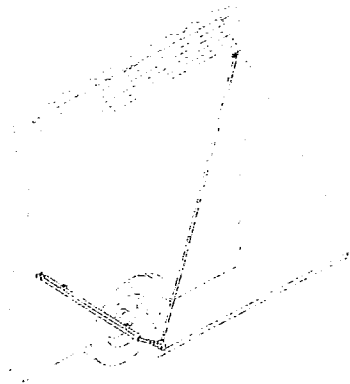

4. Fabric continues to unroll.

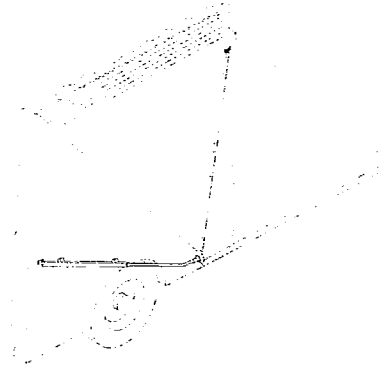

5. Air pressure extends main arms.

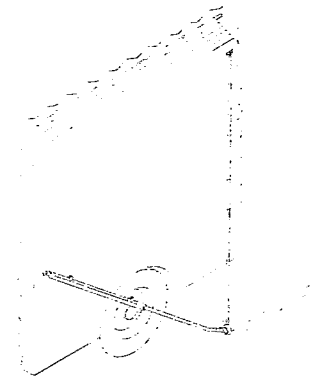

6. Fabric fully opened; Main arms locked; Gas spring rafter arms maintain fabric tautness.

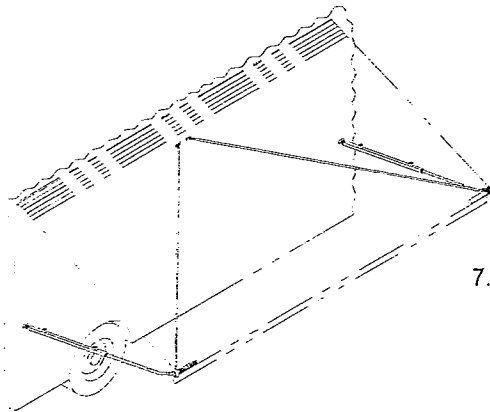

7. Awning fully opened; All air and electric off; Support arms mechanically locked open.

## LIMITED WARRANTY

### AutoAwn 24 Volt D.C. System

Zip Dee, Inc. warrants that the AutoAwn awning, except fabric and electrical components, will be free from defects in materials and workmanship under the normal use for which it was designed for as long as you (the original owner) own it.

The **motor** and related electronics are warranted for five (5) years from the original date of purchase to the original owner.

The **fabric** (not the stitching) is warranted for five (5) years against becoming unserviceable because of excessive fading (some overall color change from ultra-violet rays is often unavoidable) or loss of strength from normal exposure conditions such as sunlight, mildew and normal atmospheric chemicals. NOT COVERED: simple stains from mildew; thread deterioration.

Labor for authorized warranty repairs will be paid to approved dealers for up to the hours specified in the Warranty Labor Schedule, provided that notice of the defect is received at Zip Dee, Inc. within one (1) year from the date of purchase.

While this warranty is in effect and following written notification to Zip Dee, Inc., Zip Dee, at no cost to you, shall repair or replace the awning or any part thereof which is under warranty and which fails to function as warranted. However, this warranty shall not apply and Zip Dee, Inc. shall not be responsible to repair or replace the awning or any part thereof because of damage caused by misuse or neglect of the awning or by failure to adhere to the written operating, maintenance and installation instructions. The warranty shall not apply to any awning which has been altered or repaired by anyone other than Zip Dee or by its authorized service representatives.

This warranty for hardware and fabric does not cover damage or wear which we determine resulted from misuse, negligence or accident, including rain and wind.

This warranty is in lieu of all other warranties, expressed or implied, including any implied warranty of merchantability or any other obligation or liability on the part of Zip Dee, Inc. No person or representative is authorized to make any other warranty or assume any liability other than what is contained in this warranty. This warranty gives you specific legal rights, you may also have other legal rights which vary from state to state.

## Adjustment Procedures

### Motor Adjustments

**Note:** Motor adjustments should not be attempted except as directed in the Troubleshooting Guide or by the factory. The 24V dc motor, installed in the front end of the awning roller tube (i.e., the end nearest the front of the vehicle), provides the power to rotate the roller and wind/unwind the fabric. The motor is assisted by a powerful torsion spring installed in the rear end of the roller tube. **The motor runs** when power is applied to the motor terminals, either through the PLC program or by the motor control switch in the control box. **The motor stops running** when the program cuts power (a timed event) or when the motor reaches a limit switch located inside the motor housing.

### Direct Motor Operation

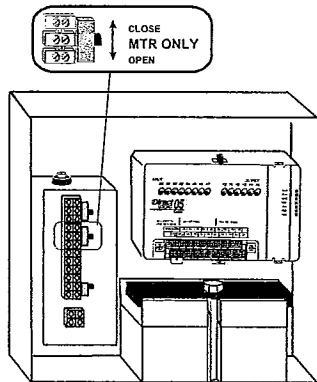

To operate the motor without running the program, open the control box door and locate the MTR slide switch located on the terminal strip (Fig. A1). Moving the slide switch to either "OPEN" or "CLOSE" will cause the roller motor to operate in that direction for as long as the switch is held. **Note: the motor will stop moving once it has reached a limit switch stop.** To test the motor, briefly slide the switch toward the command that will move the motor in the opposite direction (eg. "Open" if the awning is currently closed). This will verify that there is sufficient power to operate the motor. Also check the breaker on the Charger Box in the Control Box and reset if needed. (See Exhibit A)

Fig. A1

### Limit Switch Adjustment

The limit switches have been set and tested before vehicle delivery and seldom need adjustment. Adjustment needs to be made if the awning does not full open or close, usually due to fabric stretch or shrinkage.

Adjustments are made using the two small sockets in the exposed section of the motor at the right end of the roller tube. (Fig. A2) Use the **Motor Limit Adjusting Key** provided or a 5/32" hex wrench in the appropriate socket.

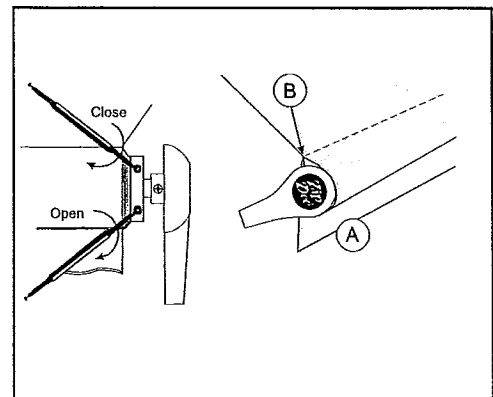

Fig. A2

### To open the awning more:

Turn the *lower* socket clockwise. One revolution will cause the awning to open about 1-1/4". Use the manual motor buttons, as described above, to operate the motor--*first* in the *opposite* direction you want to move the roller, then back again, holding the motor button until the limit switch is reached and the motor turns off. Continue adjusting the switch and "jogging" the awning back and forth until the awning is fully unrolled. At the "Fully Unrolled" position, the valance (A) will be fully extended and hang straight down from the seam of the pocket and an open "V" will be seen behind the roller tube (B). (Fig. A2)

## To close the awning more:

Turn the *upper* socket clockwise and follow the same sequence as above. **Use caution! The roller will stop if *either* the limit switch is reached or there is nothing left to wrap around the roller; in the latter case, the motor will continue to run and should open the circuit breaker in the Control Box (see Exhibit A) or the main power line fuse in the vehicle. .** Make sure the motor has stopped because it has reached the limit switch. You can do this by briefly pushing and releasing the manual CLOSE switch in the control box. If you hear an audible *click* at the motor, the motor is still under power. Turn lower socket counter clockwise until no click is heard. This indicates the limit switch has been properly set. If the motor suddenly will not run in either direction, check all breakers and fuses.

## Emergency Closing Procedures

In the unlikely event there is no power available to operate the roller motor, no air pressure to operate the arms, or the roller motor is inoperative, follow these steps to manually close the awning.

1. Unlock and retract the main arms.
  - a) **Make sure no one is under the roller tube as it may fall suddenly.**
  - b) Screw the provided manual lock release knob (or any 10/32 large head screw) into the threaded recess in the top of either main arm lock (the small box [on the main arm] that is farthest from the vehicle).
  - c) With one hand, grasp the arm tightly just in behind of the head casting. This will prevent the bar from retracting with too much force.
  - d) With the other hand, pull the release knob straight up, then allow the arm to retract gently into the tube: Repeat on the other main arm.
  - e) Unscrew the release knob and store.

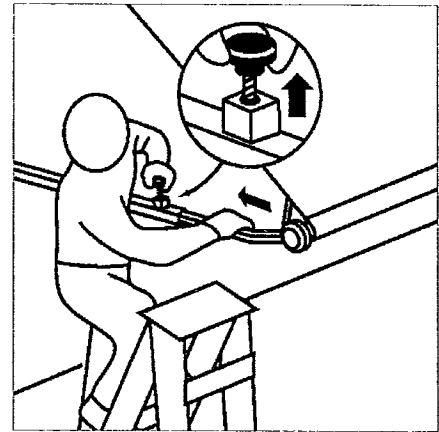

Fig. A3

2. Roll up the awning.
  - a) If batteries (in control box) are charged, use the CLOSE motor control slide switch in the control box (**Fig. A1**) Hold the switch in the "Close" direction until the awning is fully rolled up and the motor stops (by reaching the limit switch).
  - b) If batteries in control box are drained, but alternative 24 vdc power (or 2 - 12 volt batteries in series) is available, use the supplied emergency cord to provide power directly to the motor. Unplug the roller motor (at the roller) from the electrical lead that extends out of the top of the main arm and connect the emergency extension cord to lead from roller.  
*Caution: To avoid possible short circuit, cover exposed prong with tape or pull connectors (coming from terminal strip) off battery terminals.* If the motor does not run, reverse the connections at the battery.
  - c) If electric power is not available, follow these steps:

- 1) Unplug the roller motor (at the roller) from the electrical lead that extends out of the front main arm near the Head casting. (See *Caution, Step 2b*)
- 2) Disconnect rafter arms (**Fig. A4**): Unbolt from head castings using ½" hex wrench. Release set screw in rafter base on coach (3/32 hex key) and slide rafter arms off and store.
- 3) Screw the threaded end of the shaft retention tool (A) (or a 1/4-20x2" bolt with a washer under the head) through the hole in the center of the Zip Dee Logo in the front main arm head into the shaft of the motor. (**Fig. A5**) Sung tight with ½" socket wrench,--don't use excessive force. **Note: the retention tool keeps the head and motor fastened together to step 6.**

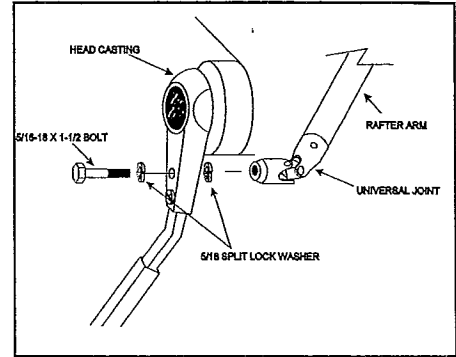

Fig. A4

- 4) Remove the 10/32 head bolt (B) that passes through the head casting and the motor shaft, along with the self-locking nut. **Note: there is spring tension present--it may be necessary to hold and twist the roller to free the bolt.**
- 5) Twist the roller a few times to roll it up manually (there should be enough spring tension present to make this easy).
- 6) Realign the holes in the motor shaft and the head casting. Reinsert and secure the head bolt. This secures the awning against the coach during travel. Unscrew and remove the shaft retention tool.

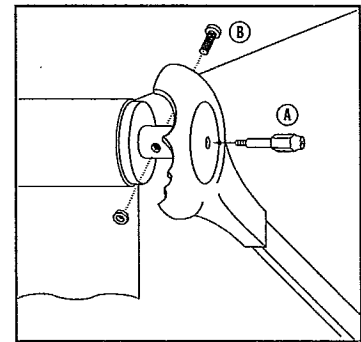

Fig. A5

#### MAIN ARM LUBRICATION (ONCE PER YEAR)

Mix a slurry of light bearing grease & machine oil ("3in1" type) to a consistency that is just about to run. Total volume of about two teaspoons. Do not use liquid oil or spray silicone. Then place this mixture into a plastic syringe or small squeeze bottle.

Open the awning by using the "mtr. Only" switch (**Fig. A1**) until the awning is at approximately a 45 degree angle from the coach. (**Fig. A6**) Pull outward on the main arms to pull the roller away from the coach until gravity allows the fabric to continue to unroll.

Remove the 1/2" hex bolt (Stop Screw) and washer, located about 6" below the lock cylinder (**Fig. A6**) and squirt half the mixture into each arm. Replace the bolt & washer.

Using the "mtr. Only" switch again. Return the awning to the closed position.

Now run the awning thru two or three complete cycles to distribute the lubrication inside of the arm. Note: control is programmed to lock out for 10 minutes between cycles to allow compressor to cool. To by-pass, turn power off and on).

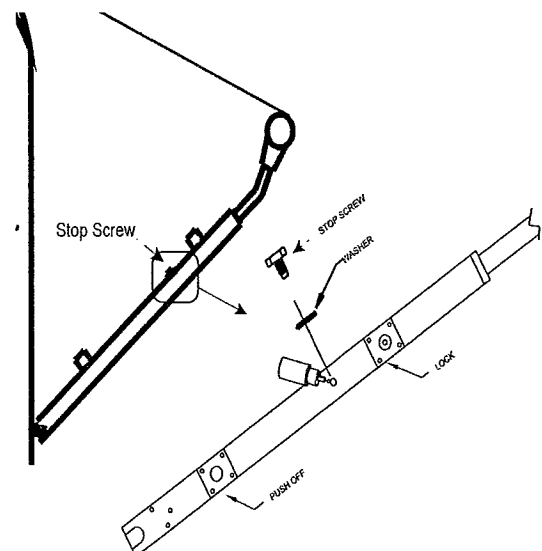

Fig. A6