

Installation Guide

Mounting by L Shape Bracket for Back Access

1. Cut the ceiling hole with the size of panel lights

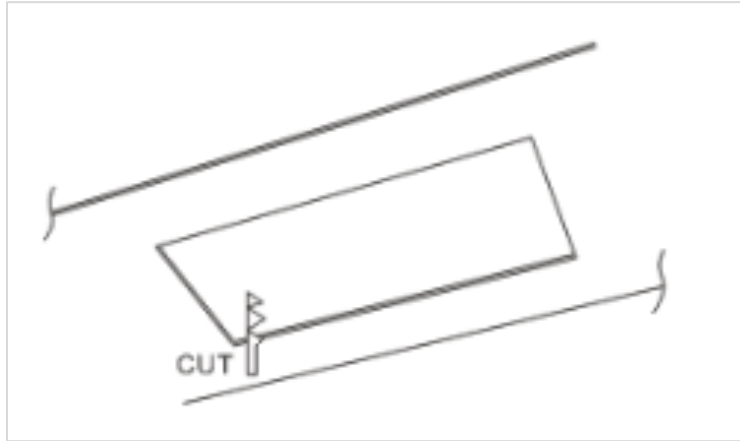

2. Put the panel lights with frame into the hole

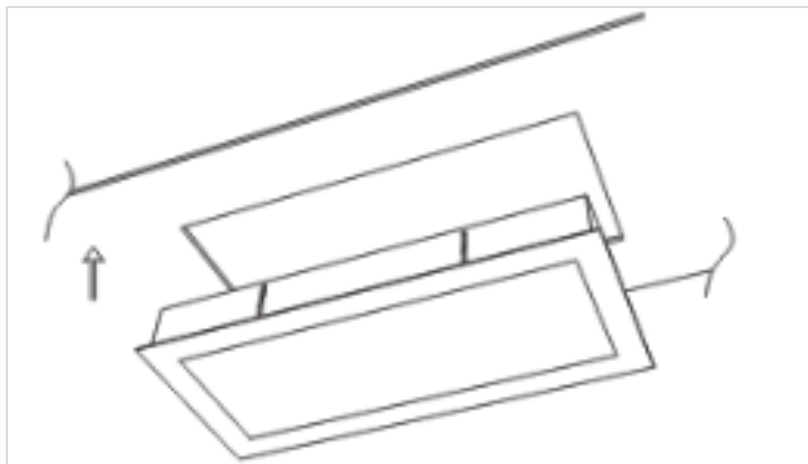

3. Adjust the L shape bracket to secure the panel lights and mount L shape bracket to the ceiling

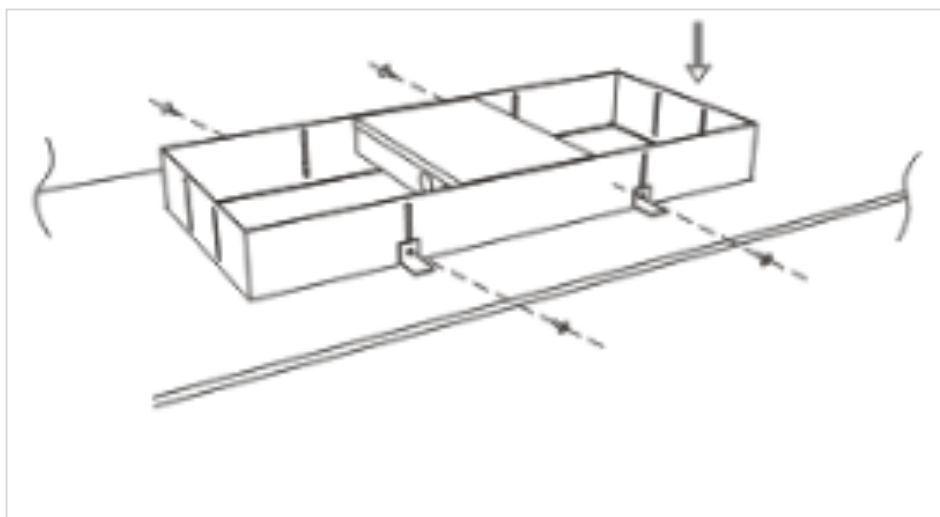

Mounting by Spring Bracket for Front Access :

1. Cut the ceiling hole with the size of panel lights

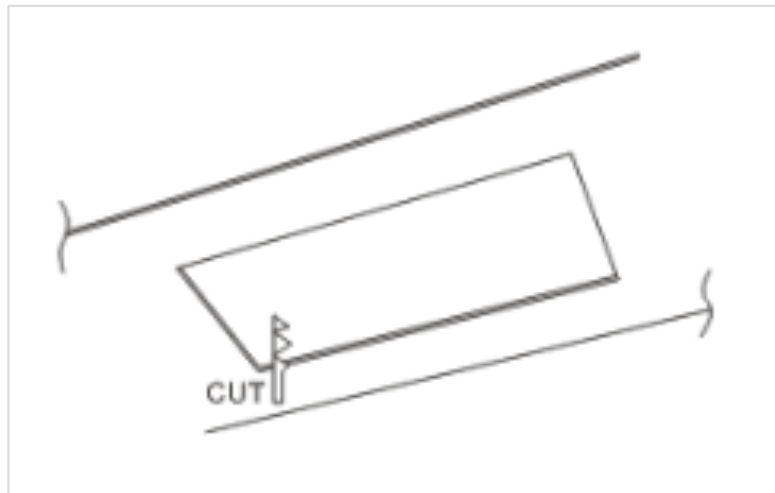

2. Secure the spring brackets to the panel light, and then push the panel lights into the hole

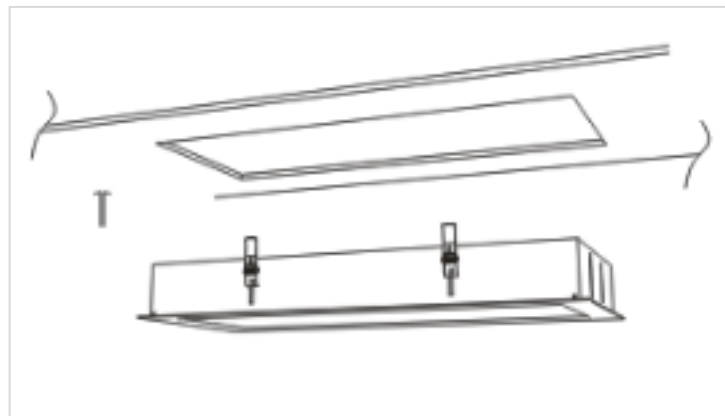

3. Make sure all spring brackets firmly attached the ceiling.

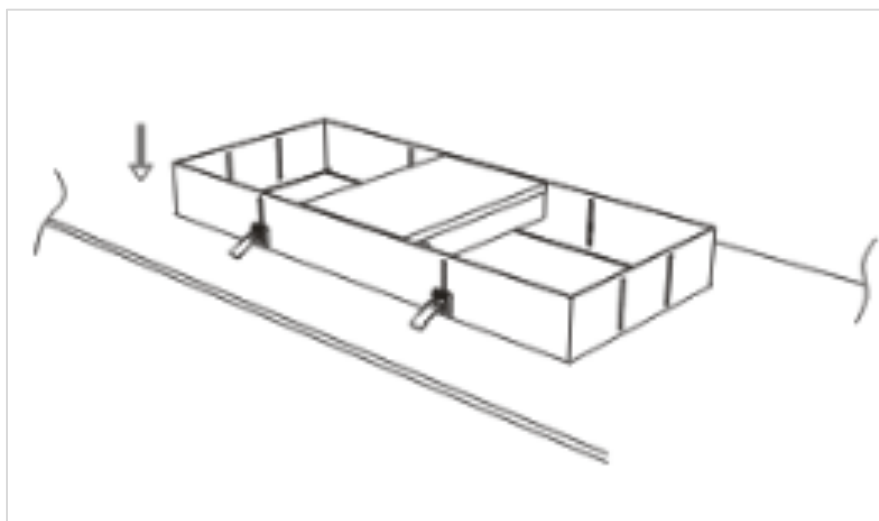

Wire Diagram

Installations without Emergency Battery Backup

1. Turn off power. Open the junction box from back.
2. Connect external Live line to the black wire of LED driver. Connect external Neutral line to the white wire of LED driver. Connect external ground wire to the metal frame of the fixture.
3. Make sure the external AC voltage is 120-277V.
4. Close the back cover the junctions. Turn on power.

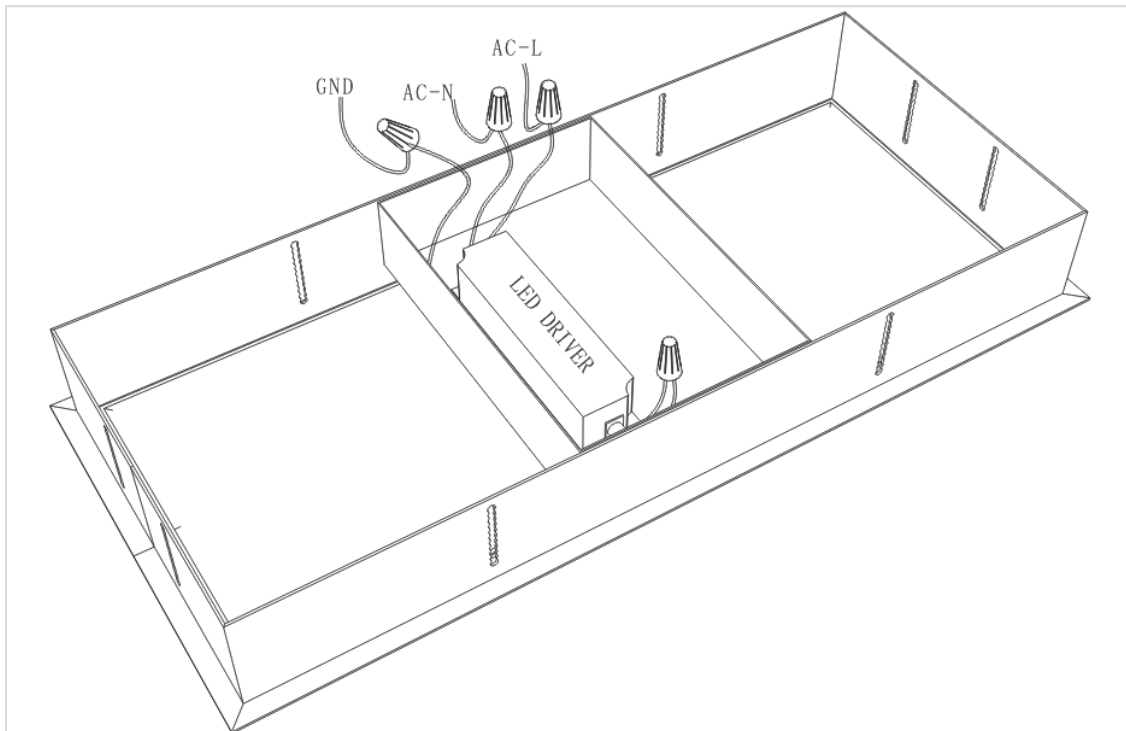

Installations with Emergency Battery Backup

1. Turn off power. Open the back cover of junction box.
2. For output side of LED driver, the red wire is positive and black wire is negative.

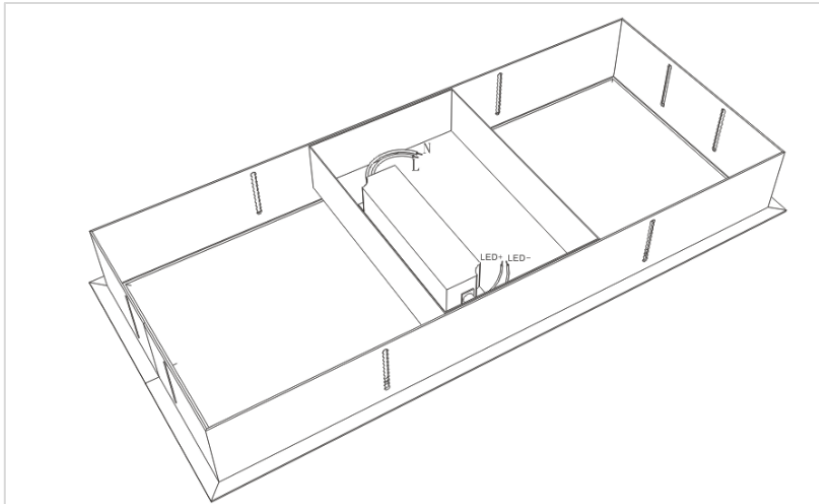

3. Connect LED driver to emergency battery back based on the following picture.

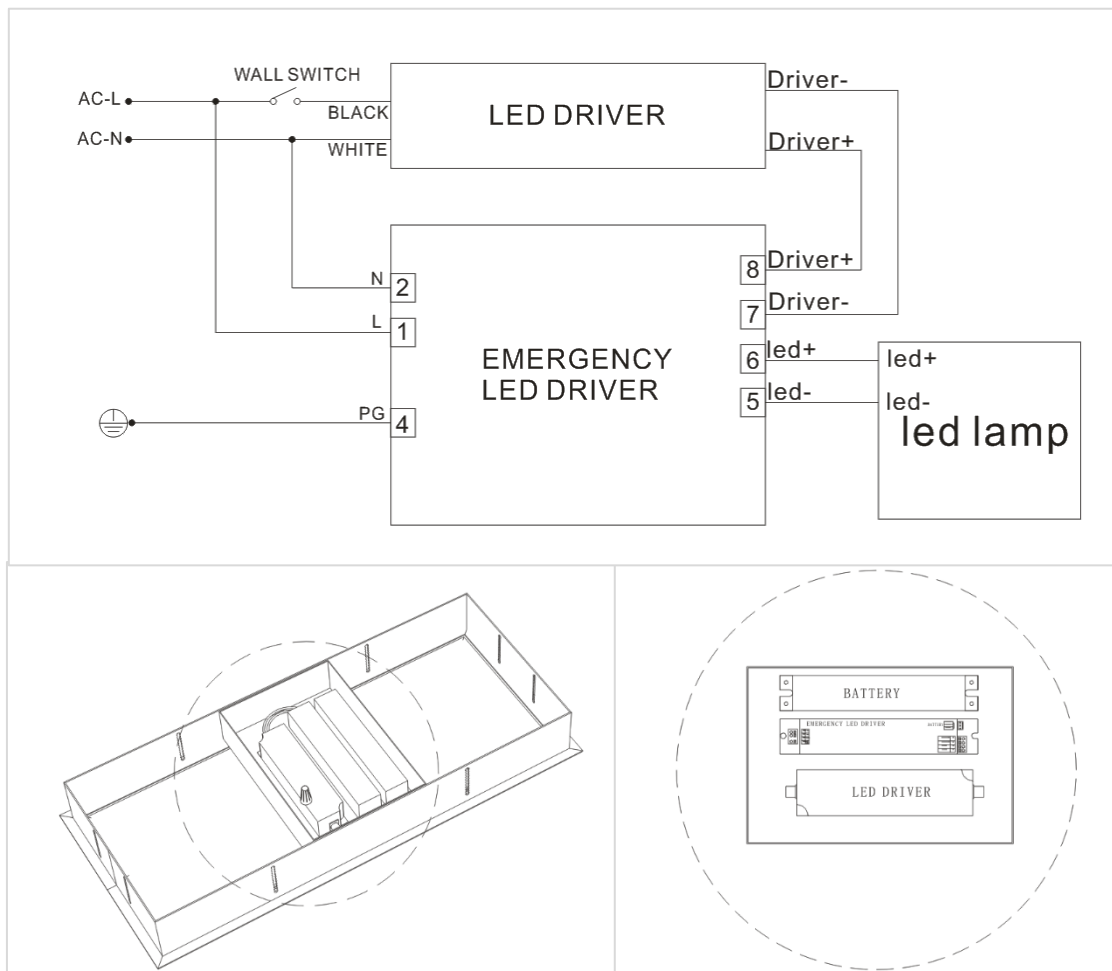

4. Make sure the external power source is 120-277 VAC.
5. Close the back cover of junction box. Turn on power.

