

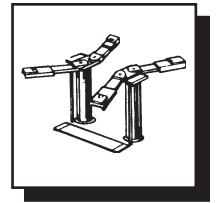

# Lift Repair Catalog



LRC1700E

S V I International, Inc. - Lift Repair Parts

August 2003

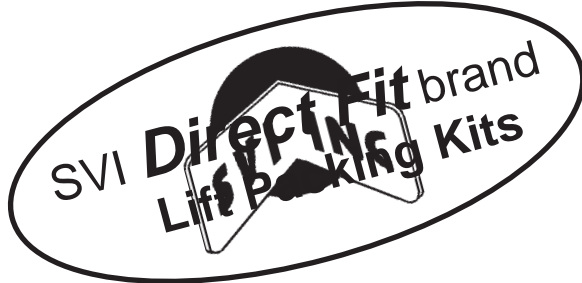

# In-Ground Lift Packing and Commonly Replaced Parts

## Also Includes:

**Packing Gland Rings**  
**Non-Rotator / Safety**  
**Legs**  
**Air and Oil Control**

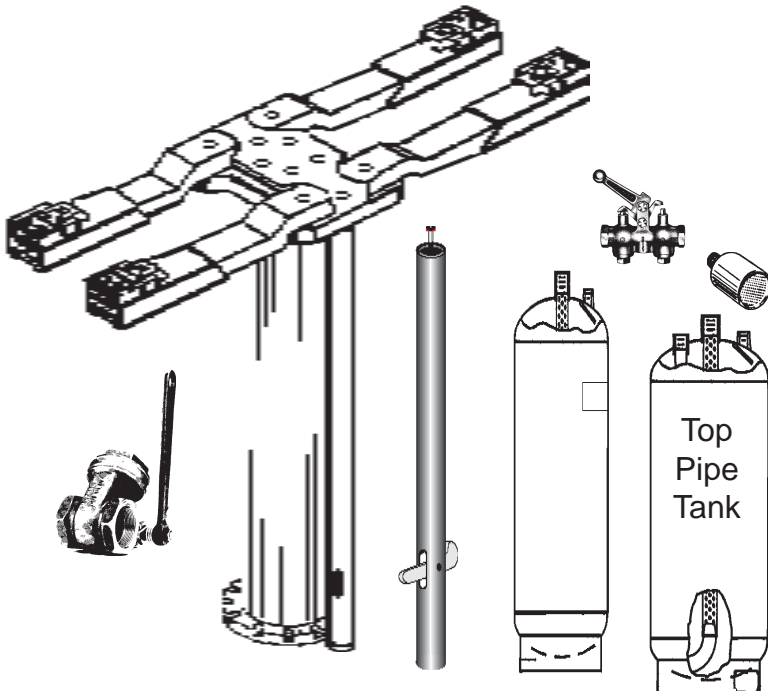

## Contents

<b>Lift Packing Quick Reference</b>	
Autoquip	page 3
Benwil	page 3
Cochin	page 3-4
Comwell	page 4
Curtis/US Air	page 5
Gilbarco/Manitowoc	pages 5 - 6
Globe/Wayne	page 7 - 11
Hallett	page 12
Hercules	page 12
Joyce	pages 13 -14
Marmac	page 15
Ottawa	page 15
Rotary	pages 15
- 16	
Stewart-Warner Alemite	page 17
U.S. Hoist	page 17
Weaver	pages 17-19
Western	page 20
<b>Metholardate Hoist Oil Lubricant</b>	page 20
<b>Non-Rotators / Safety Legs</b>	page 21
<b>Air Control Valves and Mufflers</b>	page 22
Kingston Lift Control Valves	
Central Brass Control Valves for Weaver	
<b>Oil Control Valves and Valve Repair Parts</b>	page 23
Morrison Internal and External Spring Valves	
A.Y. McDonald External Spring Valves	
Milwaukee External Spring Valves	
Apollo Ball Valve Style Valves	
<b>Lift Air/Oil Tanks</b>	page 24 - 25
Fiberglass Coating Option	
Low Oil Control Floats	
Zinc Anodes	
Pipe and Tank Wrap Tape	
<b>Lift Gland Ring Identification</b>	page 26

Entire Contents Copyright © S V I International, Inc. 2003

To Order Call: 800 321-8173 or 630-844-5566 / Fax: 800-899-1784 or 630-844-6770

All names, numbers, symbols and descriptions are used for reference purposes only. It is not implied that any part listed is the product of these manufacturers; however, some parts may be the actual product of these manufacturers.

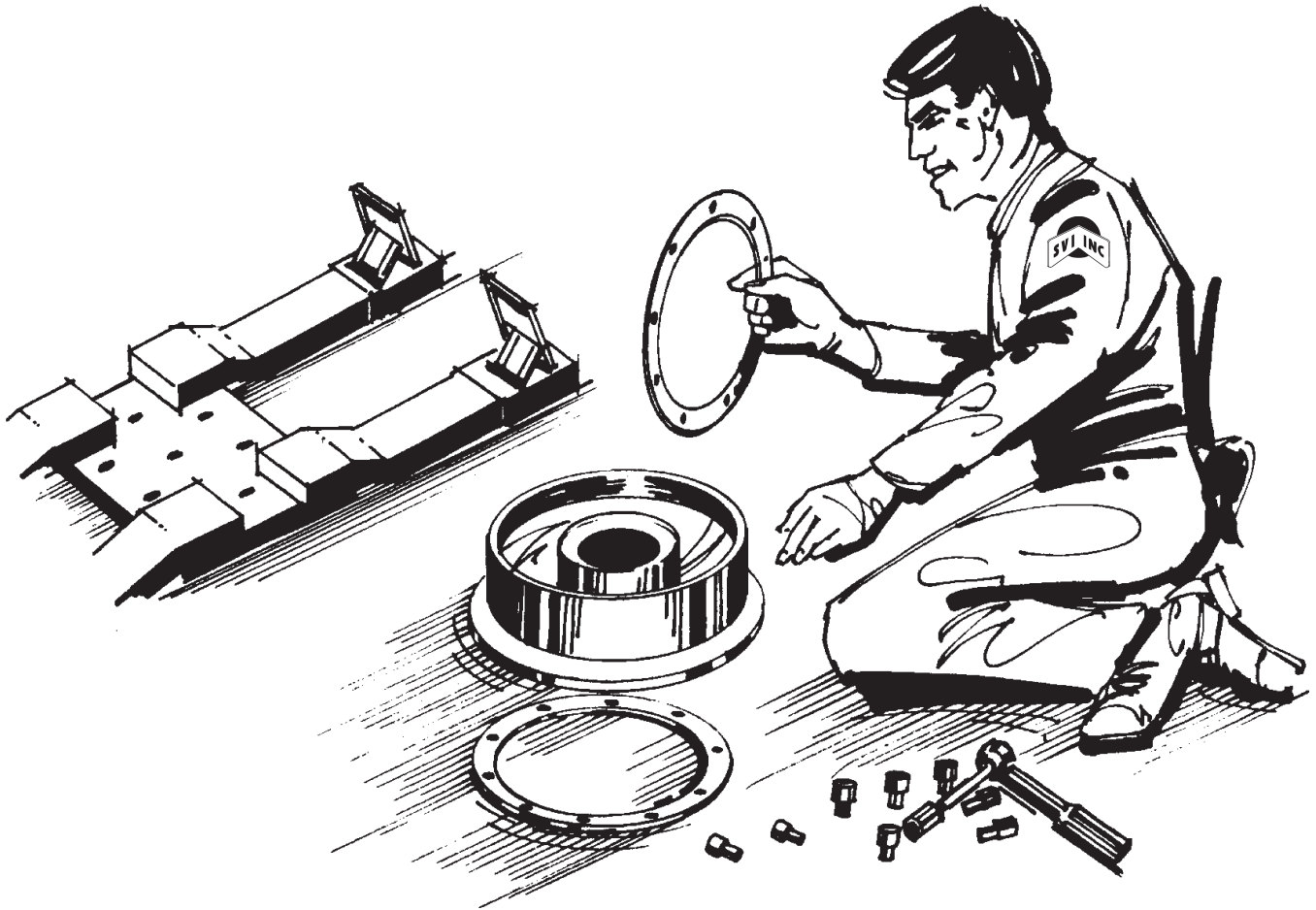

**Purchasing Lift Packing Kits without the facts can lead to slippery results.**

What Lift Repair professionals really need is 100% complete and quality inspected assurance, like that in SVI "Direct Fit" Lift Packing Kits. Instill confidence! Install SVI packing every time and turn your customers leaking problems around.



**SVI Lift Packing. Every Time.**



# In-Ground Lift Packing Quick Reference

## AUTOQUIP

S V I Lift Packing Kit	Ref. OEM Kit No.	Reference Information	Plunger Diameter	Contents and Descriptions S V I Lift Packing Kits
BH-1701	QW-10	(BR105)	10-5/8"	1 - 10-5/8" Ram Seal
BH-1701-12	QW-12		12-5/8"	1 - 12-5/8" Ram Seal

## BENWIL

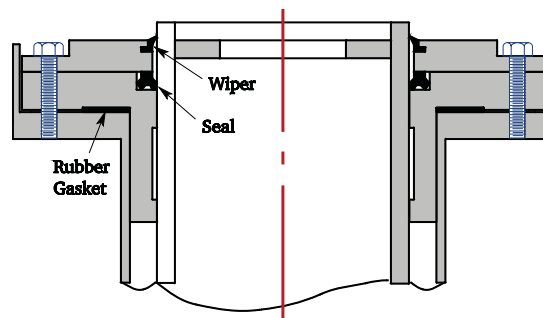

BH-1705-2	00005531	For all 8-5/8" Twin Post Hoists TPG-8, TPG-8R, TPG-8A	8-5/8"	1 - 8-5/8" ID Angled U Cup 1 - Rubber Gasket 1 - Synthetic Wiper
BH-1705	00005541	For all 10-5/8" Single Post Hoists SPG-8, SPG-8A	10-5/8"	1 - 10-5/8" ID Angled U Cup 1 - Rubber Gasket 1 - Synthetic Wiper

## COCHIN

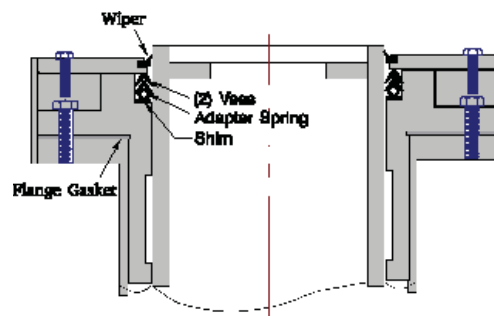

See Page 26 for Gland Ring Identification

BH-1790	L-8-340	(Easy) - Rotunda ARC-28-FH	8-1/2"	2 - 9-3/4" x 8-1/2" Synthetic Vees 1 - Adapter Spring 1 - Spring Follower Shim 1 - Gasket 1 - 1/4" x 5/16" x 27-1/4" Felt Wiper
BH-1790E	A-21605	Synthetic Rubber Wiper	8-1/2"	Optional for BH-1790 Packing Kit
BH-1790G	A-20656	Aluminum Gland Ring	8-1/2"	Optional for BH-1790 Packing Kit

To Order Call: 800 321-8173 or 630-844-5566 / Fax: 800-899-1784 or 630-844-6770

All names, numbers, symbols and descriptions are used for reference purposes only. It is not implied that any part listed is the product of these manufacturers; however, some parts may be the actual product of these manufacturers.

# In-Ground Lift Packing Quick Reference

## COCHIN (cont.)

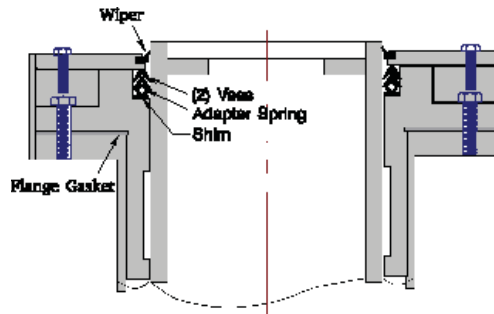

See Page 26 for Gland Ring Identification

S V I Lift Packing Kit	Ref. OEM Kit No.	Reference Information	Plunger Diameter	Contents and Descriptions S V I Lift Packing Kits
BH-1735		(Easy) - Old Style	10-1/2"	3 - 35-3/4" x 19/32" Hose Style Pkgs
BH-1737	L-10-340	(Easy) - Rotunda <i>Generally found in current and former Ford Dealership sites.</i>	10-5/8"	2 - 11-3/4" x 10-5/8" Synthetic Vees 1 - Adapter Spring 1 - Spring Follower Shim 1 - Gasket 1 - 1/4" x 5/16" x 33-1/2" Felt Wiper
BH-1737C		Polyurethane Spacer	10-5/8"	Optional for BH-1737 Packing Kit
BH-1737E	A-21606	Synthetic Rubber Wiper	10-5/8"	Optional for BH-1737 Packing Kit
BH-1737G	B-20643	Aluminum Packing Gland	10-5/8"	Optional for BH-1737 Packing Kit

## COMWELL

BH-1729		New Style 8-1/2"	8-1/2"	1 - 10-5/32" x 8-17/32" Synthetic Vee 1 - Top Adapter 1 - Bottom Adapter
BH-1730		600, 800, 301AF	10-5/8"	2 - 37-3/4" x 29/32" Hose Style Pkgs

Please Note: The Vee packing Style for new style Comwell kits is no longer available.





# In-Ground Lift Packing Quick Reference

## CURTIS/US AIR See also US Hoist

SVI Lift Packing Kit	Ref. OEM Kit No.	Reference Information	Plunger Diameter	Contents and Descriptions SVI Lift Packing Kits
BH-1734		For All 7-1/2" Curtis Rams	7-1/2"	2 - 8-3/4" x 7-1/2" Vee Rings 1 - Wiper Ring 1 - Gasket
BH-1720	A-15238	95/A-15141 See also Stewart-Warner Alemite	10-5/8"	3 - 11-1/2" x 10-1/2" Synthetic Vees 1 - 11" x 10-1/2" Wiper 1 - Gasket
BH-1732		For 10-5/8" Using 1/2" Rope Packing	10-5/8"	2 - 35-1/8" x 1/2" Hose Style Packings 2 - 35-1/8" x 1/2" Square Packings
BH-1733		FL15, RL17,RL19, RL20,, FTS36, SA59	10-5/8"	2 - 37" x 21/32" Hose Style Packings 3 - 36" x 5/8" Square Packing Rings 4 - 11-11/16" x 10-11/16" Shims

## GILBARCO/MANITOWOC

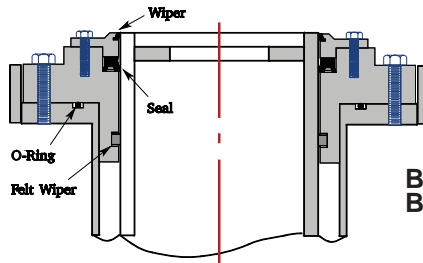

See Page 26 for Gland Ring Identification

**OEM Kits also available!**  
Look for kits ending with OE under SVI kit.

**BH-1717, BH-1707, BH-1715, BH-1716**

BH-1717	K34122	A12C, D, E & M, A120 & A121, Front Pistons A-1CJ, A-5CM, A-6CM	7-1/2"	1 - 7-1/2" x 8-1/4" x 9/16" Rubber U Cup 1 - Rubber Wiper 1 - O-ring
Cup BH-1717LS	K34122	A12C, D, E & M, A120 & A121, Front Pistons A-1CJ, A-5CM, A-6CM	7-1/2"	1 - 7-1/2" x 8-1/4" x 9/16" Fabric Ribbed U 1 - Rubber Wiper 1 - O-ring
BH-1707 or BH-1707-OE	K34115	A-12C30, D30, E30, A-12M30, M50, A-12030, A-12130, A-1CJ30, A-5CM30, A-6CM50 and all model numbers ending '0' to '9'. T08971, T09205, T11934, 936, to 984 or with dash # (T08971-01)	7-1/2"	1 - 7-1/2" x 8-1/4" x 1/2" Rubber U Cup 1 - Rubber Wiper 1 - O-ring
BH-1717-20	R34138	Packing Installation Tool	7-1/2"	1 - Tool for 7-1/2" packings
BH-1715 or BH-1715-OE	K34152	A-12D3A, E3A, M3A, N3A, J3A, A-5CM3A, A-6CM5A and all models ending with "A" through "Z". Also: T13916, T13921, T13922 or with dash #s	8-1/2"	1 - 8-1/2" x 9-1/2" x 5/8" Rubber U Cup 1 - Rubber Wiper Ring 1 - Felt Wiper 1 - O-ring
Cup BH-1715LS	K34152	A-12D3A, E3A, M3A, N3A, J3A, A-5CM3A, A-6CM5A and all models ending with "A" through "Z". Also: T13916, T13921, T13922 or with dash #s	8-1/2"	1 - 8-1/2" x 9-1/2" x 5/8" Fabric Ribbed U 1 - Rubber Wiper Ring 1 - Felt Wiper

To Order Call: 800 321-8173 or 630-844-5566 / Fax: 800-899-1784 or 630-844-6770

All names, numbers, symbols and descriptions are used for reference purposes only. It is not implied that any part listed is the product of these manufacturers; however, some parts may be the actual product of these manufacturers.

# In-Ground Lift Packing Quick Reference

## GILBARCO/MANITOWOC (cont.)

See Page 26 for Gland Ring Identification

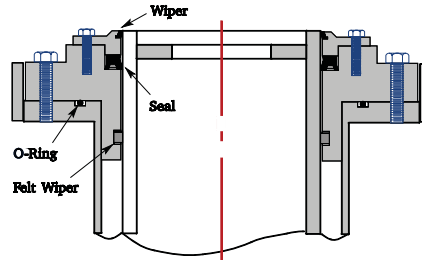

**OEM Kits also available!**  
Look for kits ending with OE under SVI kit.

**BH-1717, BH-1707, BH-1715, BH-1716  
BH-1727 (K34113) does not require the o-ring or felt wiper)**

S V I Lift Packing Kit	Ref. OEM Kit No.	Reference Information	Plunger Diameter	Contents and Descriptions S V I Lift Packing Kits
BH-1715-20	K34153	Packing Installation Tool	8-1/2"	1 - Tool for 8-1/2" packings
BH-1718 or BH-1718-OE	K34114	18-30, 18-41C, 19-30, 20-30,30-30,40-30 FCF2, 4 & 6, FSC3, 5 & 6, 12 & 13	10-5/8"	1 - 10-5/8" x 11-5/8" x 5/8" Rubber U Cup 1 - Polyurethane Wiper Ring
BH-1718LS Cup	K34114	18-30, 18-41C, 19-30, 20-30,30-30,40-30 FCF2, 4 & 6, FSC3, 5 & 6, 12 & 13	10-5/8"	1 - 10-5/8" x 11-5/8" x 5/8" Fabric Ribbed U 1 - Polyurethane Wiper Ring
BH-1722	K87582	AHA-1AA, AHA-AAB, AHA-1AP, AHA-2BM, FCF2, 4 & 6, FCS 3, 5, 12 & 13, 14 & 15, 18 & 19, 20, 30 & 31, 40 & 41, 78 & 79	10-5/8"	1 - 10-5/8" x 11-5/8" x 1/2" Rubber U Cup 1 - Polyurethane Wiper Ring
BH-1716 or BH-1716-OE	K34151	A-1AA1A, 3A, A-1AB3A, A-1AN3A, A-2BM3A, A-3BM5A, A-5CM3A, A-6CM5A,T13944,45,46,T13952,T13959 and models ending with letters "A" to "Z"	10-5/8"	1 - 10-5/8" x 11-5/8" x 5/8" Rubber U Cup 1 - Synthetic Rubber Wiper 1 - Felt Wiper 1 - O-ring
Cup BH-1716LS	K34151	A-1AA1A, 3A, A-1AB3A, A-1AN3A, A-2BM3A, A-3BM5A, A-5CM3A, A-6CM5A,T13944,45,46,T13952,T13959 and models ending with letters "A" to "Z"	10-5/8"	1 - 10-5/8" x 11-5/8" x 5/8" Fabric Ribbed U 1 - Synthetic Rubber Wiper 1 - Felt Wiper 1 - O-ring
BH-1727 or BH-1727-OE	K34113	All 10-5/8" with model numbers ending '0' to '9' except "T" models listed above. (6 Bolt Gland Ring)	10-5/8"	1 - 10-5/8" x 11-5/8" x 3/4" Urethane U Cup 1 - Polyurethane Wiper
BH-1727S	K34114 K34113 K34151 K34301 K87582	<b>Universal</b> for most 10-5/8" Lifts Note: For 3/4" Deep U Cup remove seal support rings from bottom of stuffing box.	10-5/8"	1 - 10-5/8" x 11-5/8" x 3/4" Rubber U Cup 1 - Large Base Polyurethane Wiper 1 - Small Base Rubber Wiper 1 - Felt Wiper 1 - O-ring
BH-1785		PCF2, 4 & 6, FCS3, 5, 7, 12 & 13, 14, 15,18,19,20, 30 & 31, 40 & 41, 78 & 79	10-5/8"	3 - Synthetic MM Style Rings 1 - Synthetic Rubber Wiper
BH-1716-20	K34118	Packing Installation Tool	10-5/8"	1 - Tool for 10-5/8" packings



# In-Ground Lift Packing Quick Reference

Use SVI  
"Direct Fit"  
Brand Lift Packing

## GLOBE/WAYNE

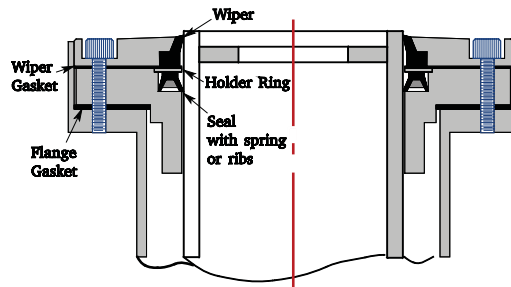

**OEM Kits  
also available!**  
Look for kits ending with  
OE under SVI kit.

See Page 26 for Gland  
Ring Identification

S V I Lift Packing Kit	Ref. OEM Kit No.	Reference Information	Plunger Diameter	Contents and Descriptions S V I Lift Packing Kits
BH-1736	A14434	MP-27 & MP-127 Fore & Aft Two Post Hoist	7-1/2"	2 - 8-3/4" x 7-1/2" Neo Fab Vees 1 - 8-3/4" x 7-1/2" Bottom Adapter 1 - Gasket 1 - Felt Wiper 1 - O'ring 6 - Springs
BH-1738 (335X7)	S-77	SR, F-27, Type 3-5 Two Post SR-27 Type 78, SR-36 Str.	7-1/2"	6 - 8-1/2" x 7-1/2" Synthetic Vees (302X751) 2 - Gaskets (B15018-310) Old Style 2 - Gaskets (B15220-310) <b>KIT PACKS BOTH POSTS</b> Optional: BH-1780-02 Rubber Wiper
BH-1739X	U70 + W74	SR-27 Type 7, 71, 72, 73	7-1/2"	1 - 9-1/2" x 7-1/2" Synthetic U Cup (323X7) 2 - Gaskets (B15015-310) 1 - Wiper (335X7)
BH-1771X	U71 + W74	SR-27 Type 1, 2, 74, 76, 77, 78, 700, 707, FS & FS-27 Type 706, SR-ER, F-77, SER-78, Type 713, S-7 Type 75-79, F-27 Type 4, 701, 702, 709, 710, V-7 Type 708	7-1/2"	1 - 9-1/2" x 7-1/2" Synthetic UCup (323X7) 2 - Gaskets (B15015-310) 1 - Gasket (B15210-308) 2 - Gaskets (B15018-310) Old Style 1 - Wiper (335X7)
BH-1779X	U73 + W74	SR-78, FS-27 Type 719, 720, 721, V-7 Type 722, ROR-278	7-1/2"	1 - 9-1/2" x 7-1/2" Synthetic U Cup (323X7) 1 - Gasket (B37453) 1 - Gasket (B37446) 1 - Wiper (335X7)
BH-1780XU or BH-1780SP-OE	UW-73	<b>Universal</b> For all 7-1/2" Diameter Plungers with U Packing	7-1/2"	1 - 9-1/2" x 7-1/2" Synthetic U Cup (323X7) 2 - Gaskets (B15015-310) 2 - Gaskets (B15018-310) Old Style 2 - Gaskets (B15220-310) 1 - Gasket (B15210-308) 1 - Gasket (B37453) 1 - Gasket (B37446) 1 - Wiper (335X7)

Please note: Some of the older leather style packings may also be available. Call S V I for details.

To Order Call: 800 321-8173 or 630-844-5566 / Fax: 800-899-1784 or 630-844-6770

All names, numbers, symbols and descriptions are used for reference purposes only. It is not implied that any part listed is the product of these manufacturers; however, some parts may be the actual product of these manufacturers.

# In-Ground Lift Packing Quick Reference

## GLOBE/WAYNE (cont.)

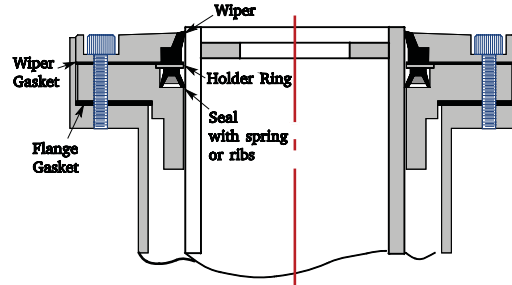

See Page 26 for Gland Ring Identification

S V I Lift Packing Kit	Ref. OEM Kit No.	Reference Information	Plunger Diameter	Contents and Descriptions S V I Lift Packing Kits
BH-1786	Q70	SR-78, FS-27, Type 715, SER-78 Type 716, EF-77	7-1/2"	1 - Quad Ring 1 - Wiper Ring (B33165-2) 1 - Gasket
BH-1742 Cup	C-10	1928-30, 1931 Standard	8-1/2"	1 - 10-1/8" X Solid x 1-1/2" x 1/4" Leather 1 - Felt Wiper (288)
BH-1743	C-11	1942-46 Standard Twin Post	8-1/2"	1 - 10-1/8" x 8-1/8" x 1-1/4" Leather Cup 1 - Gasket (79X A8125-310)
BH-1744X	S87 + W85	P-28 and SR-28 Types 83, 86, 87 S-8 Type 84 Twin Post	8-1/2"	6 - 9-1/2" x 8-1/2" Rubber Vees 2 - Top and Bottom Adapters 2 - Gaskets (B15108-310) Old Style 2 - Gaskets (B15220-310) 2 - Wipers <b>KIT PACKS BOTH POSTS</b>
BH-1745 (323X8)	UC-14	1941-1942 Superseal	8-1/2"	2 - 10-1/2" x 8-1/2" Synthetic U's (291 1 - 10-1/8" x 8-1/8" x 1-1/4" Leather Cup
BH-1746X	U81 + W85	SR, S-8, Type 82, 98, 105, P-28 and SR-28, Types 8, 81, 85, F-8, V-8, PSER, PB6036, SH, "W"	8-1/2"	1 - 10-1/2" x 8-1/2" Ribbed U (323X8) 2 - Gaskets (B15018-310) Old Style 1 - Gasket (B15220-308) 2 - Gaskets (B15220-310) 1 - Wiper (335X8)
BH-1746SP	U81 + W85	<b>Spring Style</b> SR, S-8, Type 82, 98, 105, P-28 and SR-28, Types 8, 81, 85, F-8, V-8, PSER, PB6036, SH, "W"	8-1/2"	1 - 10-1/2" x 8-1/2" Synthetic U (323X8) 1 - Spreader Spring 2 - Gaskets (B15018-310) Old Style 1 - Gasket (B15220-308) 2 - Gaskets (B15220-310) 1 - Wiper (335X8)
BH-1788X	U81 + W85	SR-28 (1951), Rear SR-78, Front SR-810 & P-28 (Type 92), FH, SH, V-8, AS, BS, FB-8, BS, ROR-278, FS-28 Side by Side	8-1/2"	1 - 10-1/2" x 8-1/2" Ribbed U (323X8) 1 - Gasket (B37444) 1 - Gasket (B37446) 1 - Wiper (335X8)

To Order Call: 800 321-8173 or 630-844-5566 / Fax: 800-899-1784 or 630-844-6770

All names, numbers, symbols and descriptions are used for reference purposes only. It is not implied that any part listed is the product of these manufacturers; however, some parts may be the actual product of these manufacturers.





# In-Ground Lift Packing Quick Reference

## GLOBE/WAYNE (cont.)

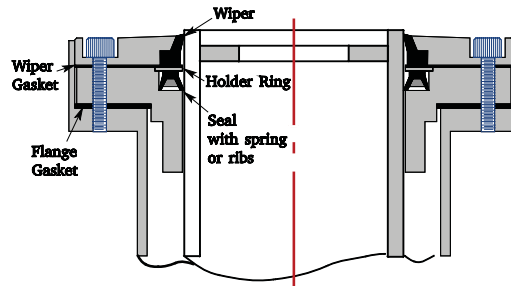

**OEM Kits  
also available!**  
Look for kits ending with  
OE under SVI kit.

See Page 26 for Gland  
Ring Identification

S V I Lift Packing Kit	Ref. OEM Kit No.	Reference Information	Plunger Diameter	Contents and Descriptions S V I Lift Packing Kits
BH-1788SP	U81 + W85	<b>Spring Style</b> SR-28 (1951), Rear SR-78, Front SR-810 & P-28 (Type 92), FH, SH, V-8, AS, BS, FB-8, BS, ROR-278, FS-28 Side by Side	8-1/2"	1 - 10-1/2" x 8-1/2" Synthetic U (323X8) 1 - Spreader Spring 1 - Gasket (B37444) 1 - Gasket (B37446) 1 - Wiper (335X8)
BH-1782XU	UW-81	<b>Universal</b> for all 8-1/2" Diameter Plungers with U Packing	8-1/2"	1 - 10-1/2" x 8-1/2" Ribbed U (323X8) 2 - Gaskets (B15018-310) Old Style 1 - Gasket (B15220-308) 2 - Gaskets (B15220-310) 1 - Gasket (B37444) 1 - Gasket (B37446) 1 - Wiper (335X8)
BH-1782SP or BH-1782SP-OE	UW-81	<b>Spring Style</b> <b>Universal</b> for all 8-1/2" Diameter Plungers with U Packing	8-1/2"	1 - 10-1/2" x 8-1/2" Synthetic U (323X8) 1 - Spreader Spring 2 - Gaskets (B15018-310) Old Style 1 - Gasket (B15220-308) 2 - Gaskets (B15220-310) 1 - Gasket (B37444) 1 - Gasket (B37446) 1 - Wiper (335X8)
BH-1789	Q73	SR, Type 108SER	8-1/2"	1 - Quad Ring 1 - Synthetic Wiper (B33165-1) 1 - Gasket (B33166)
BH-1791	C-12	1946-1947 Standard Twin Post Bottom Pack Cylinder	8-1/2"	1 - 10-1/8" x 8-1/8" x 1-1/4" Leather Cup 1 - Gasket (B15020-310)
BH-1794	C-13 C-14	1948 -15, -13 to -22 except -20 Bottom Pack Cylinder	8-1/2"	1 - 10-1/8" x 8-1/8" x 1-1/4" Leather Cup 1 - Gasket (B15020-310) 1 - Gasket (B15018-310) Old Style
BH-1747X	U100 or U101 + W-104	ER-210, SR810 Types 3 & 15, Full & Semi Hydraulic, FS-10, PFW10AS, P10AS, R1010BS	10-5/8"	1 - 12-5/8" x 10-5/8" Ribbed U Cup 2 - Gaskets (B15237-310) 2 - Gaskets (B15237-308) 1 - Wiper Seal (293 335X10)

To Order Call: 800 321-8173 or 630-844-5566 / Fax: 800-899-1784 or 630-844-6770

All names, numbers, symbols and descriptions are used for reference purposes only. It is not implied that any part listed is the product of these manufacturers; however, some parts may be the actual product of these manufacturers.

# In-Ground Lift Packing Quick Reference

## GLOBE/WAYNE (cont.)

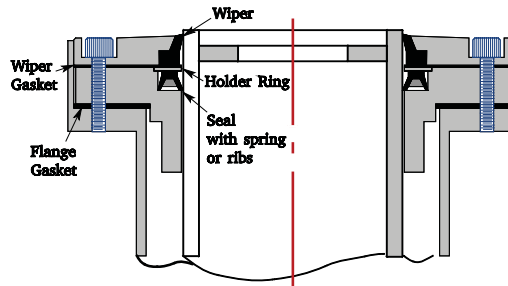

See Page 26 for Gland Ring Identification

S V I Lift Packing Kit	Ref. OEM Kit No.	Reference Information	Plunger Diameter	Contents and Descriptions S V I Lift Packing Kits
BH-1747SP	U100 or U101 + W-104	<b>Spring Style</b> ER-210, SR810 Types 3 & 15, Full & Semi Hydraulic, FS-10, PFW10AS, P10AS, R1010BS	10-5/8"	1 - 12-5/8" x 10-5/8" Synthetic U Cup 1 - Spreader Spring 2 - Gaskets (B15237-310) 2 - Gaskets (B15237-308) 1 - Wiper Seal (293 335X10)
BH-1792	Q77, MP710	Full & Semi Hydraulic using 10-5/8" Quad Ring	10-5/8"	1 - Quad Ring 1 - Synthetic Wiper (33165-3)
BH-1795X	U102 + W-104	Full & Semi Hydraulic Type 10-75, 76, 10-78 through 10-94	10-5/8"	1 - 12-5/8" x 10-5/8" Ribbed U Cup 1 - Gaskets (B35992) 2 - Gaskets (B35052) 1 - Wiper Seal (293 335X10)
BH-1795SP	U102 + W-104	<b>Spring Style</b> Full & Semi Hydraulic Type 10-75, 76, 10-78 through 10-94	10-5/8"	1 - 12-5/8" x 10-5/8" Synthetic U Cup 1 - Spreader Spring 1 - Gaskets (B35992) 2 - Gaskets (B35052) 1 - Wiper Seal (293 335X10)
BH-1797X	UP-100 + W104	<b>Pacific Globe</b> F10 & Rear SR810, Serial numbers starting with 2L, PFS10ASR	10-5/8"	1 - 12-5/8" x 10-5/8" Ribbed U Cup 2 - Gaskets (B15243-308) 1 - Wiper Seal (293 335X10)
BH-1797SP	UP-100 + W104	<b>Spring Style Pacific Globe</b> F10 & Rear SR810, Serial numbers starting with 2L, PFS10ASR	10-5/8"	1 - 12-5/8" x 10-5/8" Synthetic U Cup 1 - Spreader Spring 2 - Gaskets (B15243-308) 1 - Wiper Seal (293 335X10)
BH-1798XU	UW-102	<b>Universal</b> for all 10-5/8" Diameter Plungers with U Packing	10-5/8"	1 - 12-5/8" x 10-5/8" Ribbed U Cup 2 - Gaskets (B15237-310) 2 - Gaskets (B15237-308) 1 - Gasket (B35992) 2 - Gaskets (B35052) 2 - Gaskets (B15243-308) 1 - Wiper Seal (293 335X10)

Hold Down Rings for all 10-5/8" U Cup style packings are available. Order BH-9420-14 (Metal) BH-9420-14P (Plastic), or BH-9420-14L (2L series)



# In-Ground Lift Packing Quick Reference

## GLOBE/WAYNE (cont.)

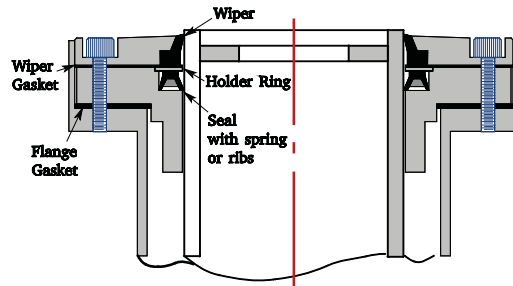

**OEM Kits  
also available!**  
Look for kits ending with  
OE under SVI kit.

See Page 26 for Gland  
Ring Identification

S V I Lift Packing Kit	Ref. OEM Kit No.	Reference Information	Plunger Diameter	Contents and Descriptions S V I Lift Packing Kits
BH-1798SP or BH-1798SP-OE	UW-102	Spring Style Universal for all 10-5/8" Diameter Plungers with U Packing	10-5/8"	1 - 12-5/8" x 10-5/8" Synthetic U Cup 1 - Spreader Spring 2 - Gaskets (B15237-310) 2 - Gaskets (B15237-308) 1 - Gasket (B35992) 2 - Gaskets (B35052) 2 - Gaskets (B15243-308) 1 - Wiper Seal (293 335X10)
(323X12) BH-1709X	UW-121	for all 12-5/8" Truck & Bus Hoists	12-5/8"	1 - 14-7/8" x 12-5/8" Ribbed U Cup 1 - Gasket 2 - Gaskets (B15256-310) 1 - Wiper Seal (293 323X12)
(323X12) BH-1709SP or BH-1709SP-OE	UW-121	Spring Style for all 12-5/8" Truck & Bus Hoists	12-5/8"	1 - 14-7/8" x 12-5/8" Rubber U Cup 1 - Spreader Spring 1 - Gasket 2 - Gaskets (B15256-310) 1 - Wiper Seal (293 323X12)
BH-1784	CL415846 CL408101	WAYNE F60686, E6068SLOC, A2520 (lift has four piece retaining ring)	10-1/2" Nominal	1 - 10-1/2" ID Quad Ring 1 - Wiper (H354500) 1 - Gasket (CL10353)
Leather BH-1772	CL2029-2	WAYNE	10-5/8"	1 - 14-1/2" x 10-9/32 x 1-3/8" x 7/32" Flange with 2 Spring Grooves
BH-1773		WAYNE A6068F	10-5/8"	1 - 36" x 1/2" Square Felt Wiper 1 - 15-3/4" x 12-7/8" x 1/16" Gasket  3 - 11-3/8" x 10-5/8" x 1-1/16" Neo-Fab Vees 1 - Top and 1 Bottom Adapter 1 - 34-1/2" Wiper 1 - 15-1/4" Gasket

Hold Down Rings for all 10-5/8" U Cup style packings are available. Order BH-9420-14 (Metal) BH-9420-14P (Plastic), or BH-9420-14L (2L series)

To Order Call: 800 321-8173 or 630-844-5566 / Fax: 800-899-1784 or 630-844-6770

All names, numbers, symbols and descriptions are used for reference purposes only. It is not implied that any part listed is the product of these manufacturers; however, some parts may be the actual product of these manufacturers.

# In-Ground Lift Packing Quick Reference

## HALLETT

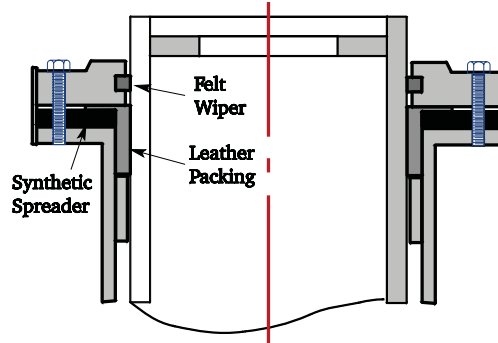

S V I Lift Packing Kit	Ref. OEM Kit No.	Reference Information	Plunger Diameter	Contents and Descriptions S V I Lift Packing Kits
BH-1756		BIRUM-HALLETT A-36 Two Post	8-1/2"	2 - 11-3/8" x 8-7/16" x 1" x 3/16" Flange 2 - Synthetic Spreaders 2 - Felt Wipers <b>KIT PACKS BOTH POSTS</b>
BH-1757		LACER-HALLETT A-33, A-34, A-35	10-1/2" to 10-5/8"	1 - 13-3/4" x 10-1/2" x 1" x 3/16" Flange 1 - Synthetic Spreader 1 - Felt Wiper
BH-1758		HALLETT - New Style A-46	10-5/8"	5 - 11-3/4" x 10-5/8" x 1-1/2" Neo-Fab Vees 1 - Bottom Adapter

## HERCULES

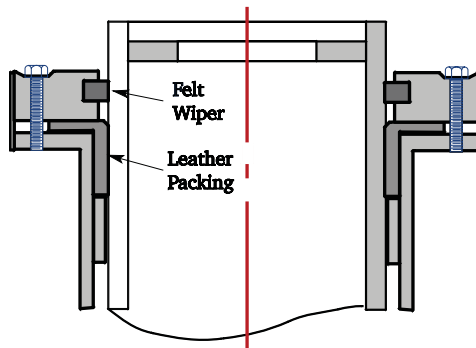

BH-1759	A	"A" and "HA"	10-5/8"	1 - 13-3/4" x 10-5/8" x 1-1/2" x 3/16" Leather Flange with 2 Spring Grooves 1 - Felt Wiper
---------	---	--------------	---------	---



# In-Ground Lift Packing Quick Reference

SVI  
"Direct Fit"  
Brand Lift Packing

## JOYCE

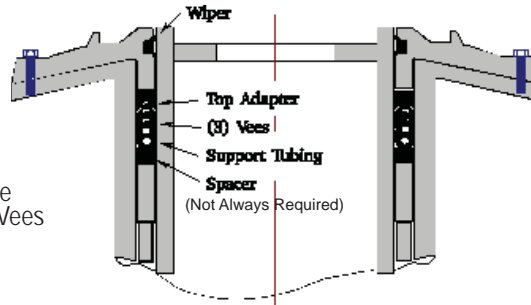

Leak Sealer Kits include  
2 Soft and 2 Standard Vees

See Page 26 for Gland  
Ring Identification

SVI Lift Packing Kit	Ref. OEM Kit No.	Reference Information	Plunger Diameter	Contents and Descriptions SVI Lift Packing Kits
BH-1723	13791 replaced by 22540 w/22506	All 7-1/2" Plungers	7-1/2"	3 - 8-1/4" x 7-1/2" Neo-Fab Vees 1 - Top Adapter 1 - 24-3/4" x 3/8" Synthetic Tubing 1 - 8-1/4" x 7-1/2" Support Ring
BH-1723S	13791 replaced by 22540 w/22506	Leak Sealer for ★ All 7-1/2" Plungers	7-1/2"	2 - 8-1/4" x 7-1/2" Neo-Fab Vees 1 - 8-1/4" x 7-1/2" Leak Sealer Vee 1 - Top Adapter 1 - 24-3/4" x 3/8" Synthetic Tubing 1 - 8-1/4" x 7-1/2" Support Ring
BH-1793	13851	All 8-1/2" Plungers	8-1/2"	5 - 9-1/4" x 8-1/2" Neo-Fab Vees 1 - Top Adapter 1 - 27-3/4" x 3/8" Synthetic Tubing 1 - 27-3/4" x 1/4" Wiper
BH-1793S	13851	Leak Sealer for ★ All 8-1/2" Plungers	8-1/2"	3 - 9-1/4" x 8-1/2" Neo-Fab Vees 2 - 9-1/4" x 8-1/2" Leak Sealer Vees 1 - Top Adapter 1 - 27-3/4" x 3/8" Synthetic Tubing 1 - 27-3/4" x 1/4" Wiper
BH-1762	12354 replaced by 22505 w/22507	All 10-1/2" New Style Plungers	10-1/2"	3 - 11-1/4" x 10-1/2" Neo-Fab Vees 1 - Top Adapter 1 - 34-3/16" x 3/8" Synthetic Tubing 1 - 34-3/16" x 3/8" Support Ring 1 - 34-3/16" x 1/2" Wiper (New Style)
BH-1762SU	12354 replaced by 22505 w/22507	Leak Sealer for ★ Special Universal for Old and New style 10-1/2" Plungers	10-1/2"	2 - 11-1/4" x 10-1/2" Neo-Fab Vees 2 - 11-1/4" x 10-1/2" Leak Sealer Vee 1 - Top Adapter 1 - 34-3/16" x 3/8" Synthetic Tubing 1 - 34-3/16" x 3/8" Support Ring 1 - 34-3/16" x 1/4" Wiper (Old Style) 1 - 34-3/16" x 1/2" Wiper (New Style)
BH-1712	13219	for all 12-1/2" Truck and Bus Lifts	12-1/2"	5 - 13-1/4" x 12-1/2" Neo-Fab Vees 1 - Top Adapter 1 - 40-1/4" x 3/8" Synthetic Tubing

SVI can provide kits for larger Joyce plungers. Call for details.

To Order Call: 800-321-8173 or 630-844-5566 / Fax: 800-899-1784 or 630-844-6770

All names, numbers, symbols and descriptions are used for reference purposes only. It is not implied that any part listed is the product of these manufacturers; however, some parts may be the actual product of these manufacturers.



# In-Ground Lift Packing Quick Reference

SVI  
"Direct Fit"  
Brand Lift Packing

"RU" Style

## JOYCE

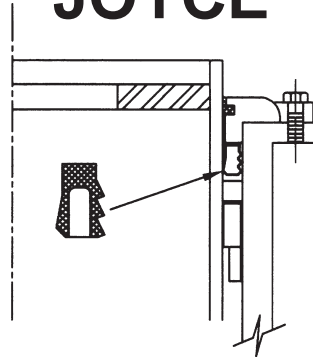

The "RU" U-cup style is a one piece, single lip seal design that installs quickly.

See Page 26 for Gland Ring Identification

SVI Lift Packing Kit	Ref. OEM Kit No.	Reference Information	Plunger Diameter	Contents and Descriptions SVI Lift Packing Kits
BH-1723RU		All 7-1/2" Plungers	7-1/2"	1 - "RU" U-cup Seal 1 - 24-3/4" x 1/4" Wiper 2 - 8-1/4" x 7-1/2" Support Rings
BH-1793RU		All 8-1/2" Plungers	8-1/2"	1 - "RU" U-cup Seal 1 - 27-3/4" x 1/4" Wiper
BH-1762RU		All 10-1/2" New and Old Style Plungers	10-1/2"	1 - "RU" U-cup Seal 1 - 34-3/16" x 1/4" Wiper 1 - 34-3/16" x 1/2" Wiper (New Style) 2 - 11-1/4" x 10-1/2" Support Rings
BH-1712RU		for 12-1/2" Truck and Bus Lifts	12-1/2"	1 - "RU" U-cup Seal 1 - 40" x 1/4" Wiper
BH-1710RU		for 13-3/4" Truck and Bus Lifts	13-3/4"	1 - "RU" U-cup Seal 1 - 44" x 1/4" Wiper
BH-1714U	34117	for 15-3/4" Truck and Bus Lifts	15-3/4"	1 - "RU" U-cup Seal 1 - 49-1/2" x 1/4" Wiper
BH-1714V	16806	for 15-3/4" Truck and Bus Lifts	15-3/4"	1 - 15-3/4" x 16-3/4" Spiral Top 4 - 15-3/4" x 16-3/4" Spiral Vee 1 - 1/2" x 1/4" Rubber Tube 1 - 49-1/2" x 1/4" Wiper

THREE SVI **"READY TO SHIP"** WAREHOUSE LOCATIONS

BALTIMORE CHICAGO LOS ANGELES



To Order Call: 800 321-8173 or 630-844-5566 / Fax: 800-899-1784 or 630-844-6770

All names, numbers, symbols and descriptions are used for reference purposes only. It is not implied that any part listed is the product of these manufacturers; however, some parts may be the actual product of these manufacturers.



# In-Ground Lift Packing Quick Reference

## MARMAC

S V I Lift Packing Kit	Ref. OEM Kit No.	Reference Information	Plunger Diameter	Contents and Descriptions S V I Lift Packing Kits
BH-1719	P-002619	All 8-1/2" Plungers	8-1/2"	4 - 9-1/4" x 8-1/2" Neo-Fab Vees 1 - 28" x 5/16" Synthetic Tubing 1 - 28-3/4" Cut Wiper

## OTTAWA

BH-1763		All 10-5/8" Plungers	10-5/8"	3 - 11-5/8" x 10-5/8" Neo-Fab Vees 1 - 11-5/8" x 10-5/8" Top Adapter 1 - 11-5/8" x 10-5/8" Bottom Adapter
---------	--	----------------------	---------	---

## ROTARY

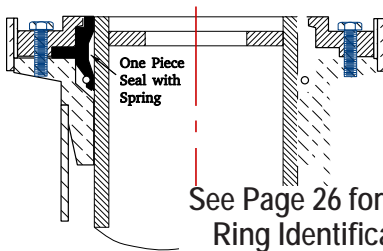

See Page 26 for Gland Ring Identification

**BH-1721, BH-1721/21B**

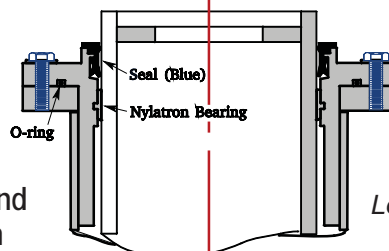

**BH-1706**

**OEM Kits also available!**  
Look for kits ending with OE under SVI kit.

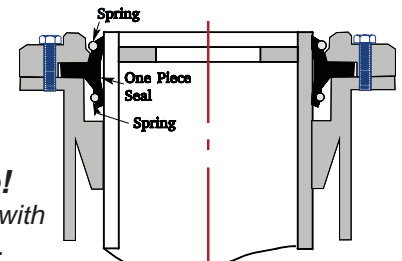

**BH-1781, BH-1767**

Jack Serial Number is located at the top of the piston on the polished surface.

BH-1777		JF34, JF218, JF120	7-1/2"	1 - 8-1/4" x 7-1/2" Seal Plus 1 O'ring
BH-9756-11	JF611	Packing Gland Ring	7-1/2"	1 - Aluminum Packing Gland
BH-1721 or BH-1721-OE	JG220	29ML, DTO28H (Older Style), FH28H, WABU28H, AP50, & * Models AC60. Jack Serial Numbers ending JG149-JG187	8-1/2"	1 - Double Lip Seal with Spring
BH-1721B or BH-1721B-OE	JG620	Packing Gland Ring	8-1/2"	1 - Aluminum Packing Gland
BH-1721/21B or BH-1721/21B-OE	J136	Packing and Gland Combo Kit Includes Bleeder Valve and Hardware	8-1/2"	1 - BH-1721 Packing with Spring 1 - BH-1721B Aluminum Pkg. Gland 1 - FK-60-125 Bleeder Valve
BH-1721-139 or BH-1721-139-OE	J139	Packing, Gland, Spacer Combo Kit Includes Bleeder Valve and Hardware	8-1/2"	1 - BH-1721 Packing with Spring 1 - BH-1721B Aluminum Pkg. Gland 1 - FK-60-125 Bleeder Valve 1 - Spacer
BH-1706 or BH-1706-OE	JG227	New Style (Blue) Seal for DTO28H, JG188/JG189 and above Series Jacks	8-1/2"	New Style - Lip Seal w/ O-ring Spreader Wiper is incorporated in the seal
BH-1764	JK220	Jack Serial Numbers Starting C,M,T,V	8-1/2" 9-1/2" 10-1/2"	2 - 27" x 1/2" Round Hose Packings 3 - 36" x 1/2" Square Packings 1 - Felt Wiper 1 - Duck and Rubber Shim

To Order Call: 800 321-8173 or 630-844-5566 / Fax: 800-899-1784 or 630-844-6770

All names, numbers, symbols and descriptions are used for reference purposes only. It is not implied that any part listed is the product of these manufacturers; however, some parts may be the actual product of these manufacturers.

# In-Ground Lift Packing Quick Reference

## ROTARY (cont.)

**OEM Kits also available!**  
Look for kits ending with OE under SVI kit.

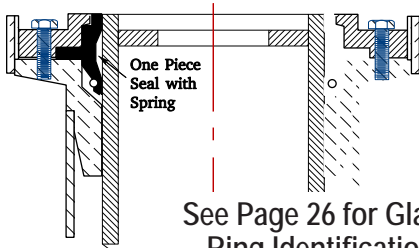

See Page 26 for Gland Ring Identification

**BH-1799, BH-1799/99B**

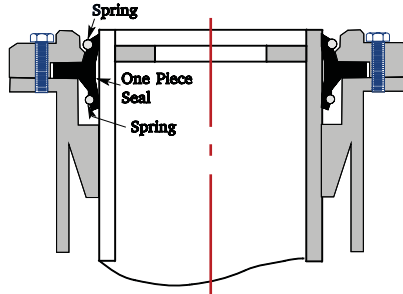

**BH-1781, BH-1767, BH-1708**

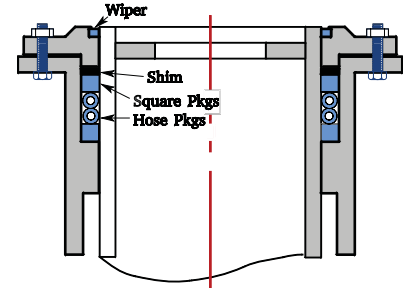

**BH-1764, BH-1765, BH-1766**

Jack Serial Number is located at the top of the piston on the polished surface.

S V I Lift Packing Kit	Ref. OEM Kit No.	Reference Information	Plunger Diameter	Contents and Descriptions S V I Lift Packing Kits
BH-1766 or BH-1766-OE	JK223	10-5/8" Jack Serial Numbers ending JK135-JK157. 8-1/2" Jack Serial Numbers ending JK118-JK127	8-1/2" 10-5/8"	1 - 36" x 1/2" Round Hose Packing 2 - 36" x 1/2" Square Packings 1 - Felt Wiper 1 - Duck and Rubber Shim
BH-1781	JG218	Old Style Twin Post Hoists 28ML, 28MLS, 29ML, Jack Serial #'s ending JG128-JG148	8-1/2"	1 Piece Double Lip Seal with 2 Springs
BH-1774-CA	ACS-1580	Old Style Rotary/Dover Canadian Lifts for FP47A & H with serial numbers W-1029 through W-2489	10-5/8"	4 - Neo-Fab Vee Packings 1 - Wiper 1 - Gasket 2 - 37" x 3/4" Round Hose Packings
BH-1765 or BH-1765-OE	JK221	Jack Serial Numbers with "W" and ending JK124-JK134	10-5/8"	2 - 36" x 5/8" Square Packings 1 - Felt Wiper 1 - Duck and Rubber Shim
BH-1767 or BH-1767-OE	JK225	Jack Serial Numbers ending JK158 thru JK1112 Manufactured 1954 - 1966	10-5/8"	1 Piece Double Lip Seal with 2 Springs
BH-1799 or BH-1799-OE	JK227	10AF, 10HF, 20AR, 20HR, 31AR, 31HR, 35AR, HR, T110, T210 series, T1010, FP10A, H, FP11A, H, 12A, H, 36A, FP45A, H, VM5A & H, VMIL7A, VMTTL6H, AT70H, E and 10-5/8" jack for 810ML, MLS, 811ML, AC60H, E. Jack Serial numbers JK158 to JK1136 and up.	10-5/8"	New Style - Double Lip Seal with Spring
BH-1799B or BH-1799B-OE	JK622	Packing Gland Ring	10-5/8"	1 - Aluminum Packing Gland
BH-1799/99B or BH-1799/99B-OE	J134	Packing and Gland Combo Kit Includes Bleeder Valve	10-5/8"	1 - BH-1799 Packing with Spring 1 - BH-1799B Aluminum Packing Gland 1 - FK-60-125 Bleeder Valve
BH-9762-81	JK238	Seal and Wiper	10-5/8"	New Style - Lip Seal w/ O-ring Spreader Wiper is incorporated in the seal
BH-1708 or BH-1708-OE	JL220	For all 12-5/8" Truck and Bus Hoists	12-5/8"	1 Piece Double Lip Seal with 2 Springs
BH-9771-01	JL612	Packing Gland Ring	12-5/8"	1 - Aluminum Packing Gland

To Order Call: 800 321-8173 or 630-844-5566 / Fax: 800-899-1784 or 630-844-6770

All names, numbers, symbols and descriptions are used for reference purposes only. It is not implied that any part listed is the product of these manufacturers; however, some parts may be the actual product of these manufacturers.





# In-Ground Lift Packing Quick Reference

## STEWART-WARNER ALEMITE

S V I Lift Packing Kit	Ref. OEM Kit No.	Reference Information	Plunger Diameter	Contents and Descriptions S V I Lift Packing Kits
BH-1720			10-5/8"	3 - 11-1/2" x 10-1/2" Synthetic Vees 1 - 11" x 10-1/2" Wiper 1 - Gasket

## U.S. HOIST

BH-1769		For Most Single Post Lifts	10-5/8"	2 - 38" x 29/32" Synthetic Round Pkgs. 2 - 36" x 7/8" Square Packing 1 - Felt Wiper 1 - 15-7/16" x 12-1/2" x 1/16" Gasket
BH-1796		For Most Twin Post Lifts	10-5/8"	3 - 11-5/8" x 10-5/8" x 15/16" Vee 1 - Bottom Adapter

## WEAVER

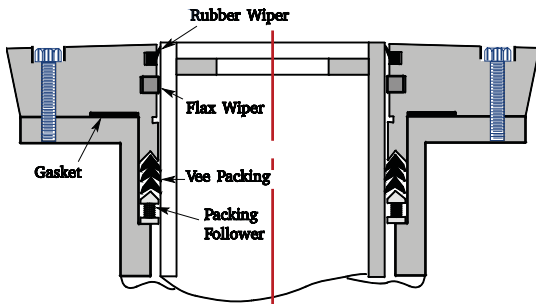

BH-1724, BH-1724S

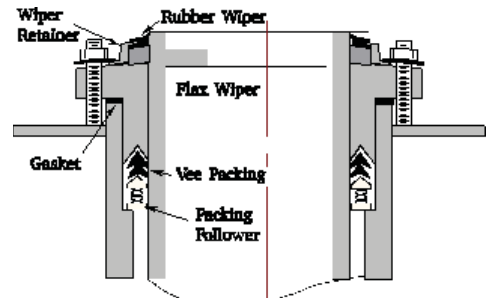

BH-1775

See Page 26 for Gland Ring Identification

BH-1724	KL162	EC284, EC285 and all EC500 series, EC-081, EC-881B, EC891 Twin Post Side by Side Lifts	7-1/2"	2 - 8-3/4" x 7-1/2" Vees (S5857) 1 - 25-1/4" x 3/8" Square Wiper (S18868) 1 - Rubber Wiper (S18867) 1 - 9-1/2" x 8-3/4" x 1/16" Gasket (S5858)
BH-1724S	KL162	<b>Leak Sealer Kit</b> ★ EC284, EC285 and all EC500 series, EC-081, EC-881B, EC891 Twin Post Side by Side lifts	7-1/2"	1 - 8-3/4" x 7-1/2" Vees (S5857) 1 - 8-3/4" x 7-1/2" Leak Sealer Vee 1 - 25-1/4" x 3/8" Square Wiper (S18868) 1 - Rubber Wiper (S18867) 1 - 9-1/2" x 8-3/4" x 1/16" Gasket (S5858)
BH-1775	KL161	EC100, EC101, EC102, 103 and Front only EC107, 108 Twin Post Fore and Aft Lifts	7-1/2"	2 - 8-3/4" x 7-1/2" Vees (S5857) 1 - 26-1/4" x 1/2" Square Wiper (S5885) 1 - Rubber Wiper (12977) 1 - 9-1/2" x 8-3/4" x 1/16" Gasket (S5858)

**Important Note:** When using Leak Sealer Kit or Vee we recommend installing the Leak Sealer Vee on top, or last.

To Order Call: 800 321-8173 or 630-844-5566 / Fax: 800-899-1784 or 630-844-6770

All names, numbers, symbols and descriptions are used for reference purposes only. It is not implied that any part listed is the product of these manufacturers; however, some parts may be the actual product of these manufacturers.

# In-Ground Lift Packing Quick Reference

## WEAVER (cont.)

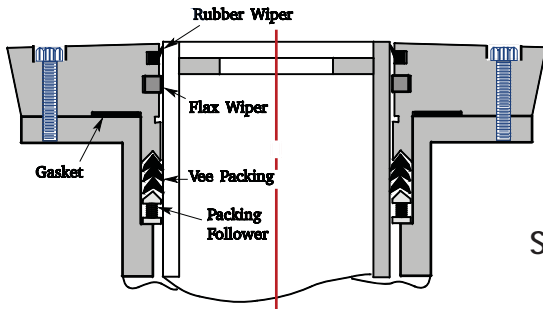

BH-1725, BH-1725S

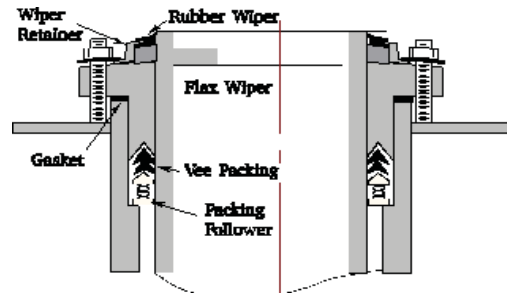

BH-1775, BH-1775S, BH-1776

See Page 26 for Gland Ring Identification

S V I Lift Packing Kit	Ref. OEM Kit No.	Reference Information	Plunger Diameter	Contents and Descriptions S V I Lift Packing Kits
BH-1775S	KL161	<b>Leak Sealer Kit</b> ★ EC100, EC101, EC102, 103 and Front only EC107, 108 Twin Post Fore and Aft Lifts	7-1/2"	1 - 8-3/4" x 7-1/2" Vee (S5857) 1 - 8-3/4" x 7-1/2" Leak Sealer Vee 1 - 26-1/4" x 1/2" Square Wiper (S5885) 1 - Rubber Wiper (12977) 1 - 9-1/2" x 8-3/4" x 1/16" Gasket (S5858)
BH-1702U		<b>Universal</b> for all 7-1/2" Diameter Posts	7-1/2"	2 - 8-3/4" x 7-1/2" Vees (S5857) 1 - 25-1/4" x 3/8" Square Wiper (S18868) 1 - 26-1/4" x 1/2" Square Wiper (S5885) 1 - Rubber Wiper (12977) 1 - Rubber Wiper (S18867) 1 - 9-1/2" x 8-3/4" x 1/16" Gasket (S5858)
BH-1702SU		<b>Leak Sealer Universal</b> ★ for all 7-1/2" Diameter Posts	7-1/2"	1 - 8-3/4" x 7-1/2" Vees (S5857) 1 - 8-3/4" x 7-1/2" Leak Sealer Vee 1 - 25-1/4" x 3/8" Square Wiper (S18868) 1 - 26-1/4" x 1/2" Square Wiper (S5885) 1 - Rubber Wiper (12977) 1 - Rubber Wiper (S18867) 1 - 9-1/2" x 8-3/4" x 1/16" Gasket
BH-1725	KL159	All Single Post Lifts EC183, EC383, 184, 193, 194, EC183, 184VW, 383VW, EC400, EC600 series	10-5/8"	3 - 12" x 10-5/8" Vees (S6455) 1 - 34-3/4" x 3/8" Square Wiper (S17118) 1 - Rubber Wiper (S17108) 1 - 13" x 12-1/8" x 1/16" Gasket (S6452)
BH-1725S	KL159	<b>Leak Sealer Kit</b> ★ EC183, EC383, 184, 193, 194, EC183, 184VW, 383VW, EC400, EC600 series (Single Post)	10-5/8"	2 - 12" x 10-5/8" Vees (S6455) 1 - 12" x 10-5/8" Leak Sealer Vee 1 - 34-3/4" x 3/8" Square Wiper (S17118) 1 - Rubber Wiper (S17108) 1 - 13" x 12-1/8" x 1/16" Gasket (S6452)
BH-1776	KL160	EC105, EC106, 196, 197 and Rear only EC107, 108, 183 and 184 (For Twin and Multi Post hoists)	10-5/8"	3 - 12" x 10-5/8" Vees (S6455) 1 - 36-1/2" x 1/2" Square Wiper (S6456) 1 - Rubber Wiper (S13145) 1 - 13" x 12-1/8" x 1/16" Gasket (S6452)

**Important Note:** When using Leak Sealer Kit or Vee we recommend installing the Leak Sealer Vee on top, or last.

To Order Call: 800 321-8173 or 630-844-5566 / Fax: 800-899-1784 or 630-844-6770

All names, numbers, symbols and descriptions are used for reference purposes only. It is not implied that any part listed is the product of these manufacturers; however, some parts may be the actual product of these manufacturers.



# In-Ground Lift Packing Quick Reference

## WEAVER (cont.)

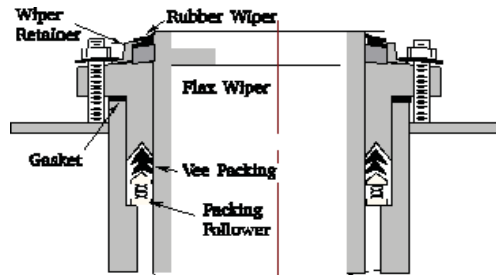

BH-1776S, BH-1713

See Page 26 for Gland  
Ring Identification

S V I Lift Packing Kit	Ref. OEM Kit No.	Reference Information	Plunger Diameter	Contents and Descriptions S V I Lift Packing Kits
BH-1776S	KL160	Leak Sealer Kit ★ EC105, EC106, 196, 197 and Rear only EC107, 108 (For Twin and Multi Post lifts)	10-5/8"	2 - 12" x 10-5/8" Vees (S6455) 1 - 12 x 10-5/8" Leak Sealer Vee 1 - 34-1/2" x 1/2" Square Wiper (S6456) 1 - Rubber Wiper (S13145) 1 - 13" x 12-1/8" x 1/16" Gasket (S6452)
BH-1704U		Universal for all 10-5/8" Diameter Posts	10-5/8"	3 - 12" x 10-5/8" Vees (S6455) 1 - 34-3/4" x 3/8" Square Wiper (S17118) 1 - 36-1/2" x 1/2" Square Wiper (S6456) 1 - Rubber Wiper (S17108) 1 - Rubber Wiper (S13145) 1 - 13" x 12-1/8" x 1/16" Gasket (S6452)
BH-1704SU		Leak Sealer Universal ★ for all 10-5/8" Diameter Posts	10-5/8"	2 - 12" x 10-5/8" Vees (S6455) 1 - 12 x 10-5/8" Leak Sealer Vee 1 - 36-1/2" x 3/8" Square Wiper (S17118) 1 - 34-3/4" x 1/2" Square Wiper (S6456) 1 - Rubber Wiper (S17108) 1 - Rubber Wiper (S13145) 1 - 13" x 12-1/8" x 1/16" Gasket (S6452)
BH-1713	KL-268	for all 12-5/8" Truck and Bus Lifts	12-5/8"	3 - 15-7/16" x 12-5/8" Vees (1084625) 1 - 41" x 1/2" Square Wiper (1084628) 1 - Rubber Wiper (1084627) 1 - 15-15/16" x 15-1/4" x 1/16" Gasket
BH-1713S	KL-268	Leak Sealer Kit ★ for all 12-5/8" Truck and Bus Lifts	12-5/8"	2 - 15-7/16" x 12-5/8" Vees (1084625) 1 - 15-7/16" x 12-5/8" Leak Sealer Vee 1 - 41" x 1/2" Square Wiper (1084628) 1 - Rubber Wiper (1084627) 1 - 15-15/16" x 15-1/4" x 1/16" Gasket
BH-1702T		Packing Installation Tool		1 - Installation Tool for all Weaver Kits

**Important Note:** When using Leak Sealer Kit or Vee we recommend installing the Leak Sealer Vee on top, or last.

To Order Call: 800 321-8173 or 630-844-5566 / Fax: 800-899-1784 or 630-844-6770

All names, numbers, symbols and descriptions are used for reference purposes only. It is not implied that any part listed is the product of these manufacturers; however, some parts may be the actual product of these manufacturers.

# In-Ground Lift Packing Quick Reference

**"Spring Style Seal"  
Now Available in  
Leak Sealer Version!** ★

## WESTERN

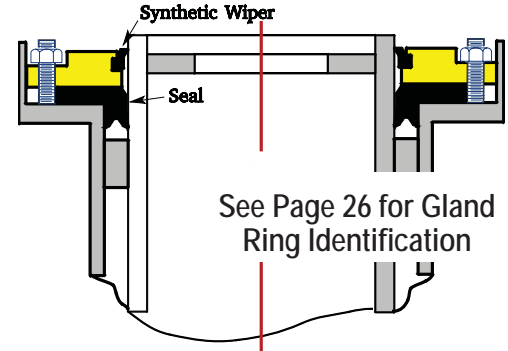
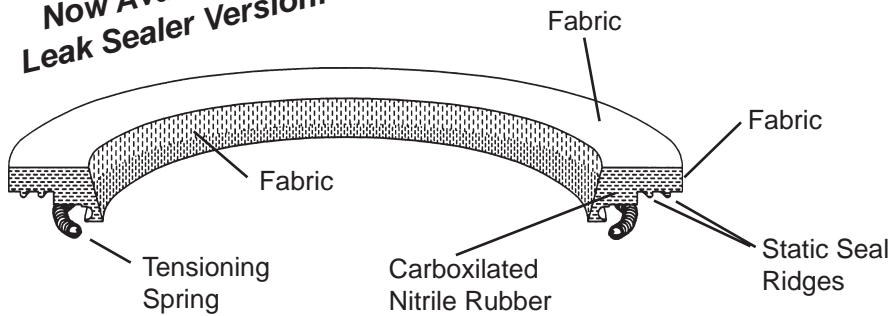

S V I Lift Packing Kit	Ref. OEM Kit No.	Reference Information	Plunger Diameter	Contents and Descriptions S V I Lift Packing Kits
BH-1778-2Blue	U-215	For All New Style 8-1/2" Posts	8-1/2"	1 - Blue Style Flange Style Packing Seal 1 - Felt Wiper
BH-1778-2SP	U-216	Spring Style Fabric & Rubber Seal Includes Spring	8-1/2"	1 - Fabric & Rubber Flange Seal & Spring 1 - Felt Wiper
BH-1778-2LS	U-216	★ Leak Sealer - Spring Style Fabric & Rubber Seal Includes Spring (special compound)	8-1/2"	1 - Fabric & Rubber Flange Seal & Spring 1 - Felt Wiper
BH-1778-2B	U-232	Rubber Wiper	8-1/2"	Optional Rubber Wiper
BH-1778-2D	U-220	Packing Gland Ring & Wiper Combo	8-1/2"	1 - Aluminum Packing Gland & Wiper
BH-1778Blue	U-200	For All New Style 10-5/8" Posts	10-5/8"	1 - Blue Style Flange Packing Seal 1 - Felt Wiper
BH-1778SP	U-201	Spring Style Fabric & Rubber Seal Includes Spring	10-5/8"	1 - Fabric & Rubber Flange Seal & Spring 1 - Felt Wiper
BH-1778LS	U-201	★ Leak Sealer - Spring Style Fabric & Rubber Seal Includes Spring (special compound)	10-5/8"	1 - Fabric & Rubber Flange Seal & Spring 1 - Felt Wiper
BH-1778B	U-212	Rubber Wiper	10-5/8"	Optional Rubber Wiper
BH-1778D	U-205	Packing Gland Ring & Wiper Ring Combo	10-5/8"	1 - Aluminum Packing Gland & Wiper
BH-1703	U-250	For all 12-5/8" Truck and Bus Hoists	12-5/8"	1 - Black Rubber Flange Packing

## METHOLARDATE LIFT OIL ADDITIVE

Metholardate eliminates chatter in lifts by adding lubricity to the hydraulic oil. Metholardate is recommended for all automotive lifts. It is very effective when the lift seals are new. New seals tend to provide more sealing surface which can cause the lift to stick on its way down. Metholardate cures this. It is recommended with every in-ground lift seal change and anytime the lift is chattering.

- BH-9960-01      1 Gallon Can Metholardate with instructions
- BH-9960-05      5 Gallon Pail Metholardate with instructions
- BH-9960-25      1 Quart Can Metholardate with instructions

**To Order Call: 800 321-8173 or 630-844-5566 / Fax: 800-899-1784 or 630-844-6770**

All names, numbers, symbols and descriptions are used for reference purposes only. It is not implied that any part listed is the product of these manufacturers; however, some parts may be the actual product of these manufacturers.



# NON-ROTATOR / SAFETY LEGS FOR ALL AUTO, BUS & TRUCK LIFTS

or twisted non-rotator on most single post lifts. S V I has the most complete line available. This includes standard foot release non-rotators (EL series) for all single post lifts, Top Release Non-Rotators, Non-Rotators for Weaver and Globe Fore and Aft lifts, Three hole Non-Rotators for Joyce Lifts, Top Release Non-rotators for Rotary Moveable PistonLifts, and Non-Rotators for Benwil lifts.

Standard non-rotators are available in two popular styles. The EL series are the standard economical foot release models. They fit into the existing sleeve and bolt to the superstructure. The safety lock automatically swings into the locked position as the lift is raised. Prior to lowering the lift the lock is simply moved to the unlock position and the hoist can be safely lowered. For additional ease and hoists that do not provide good access to the foot level lock (deep yoke hoists for example) S V I also offers the TR series top release

- Customs Avail
- Request
- Standard EL Se
- Release Non-Rota
- TR Series Top
- Non Rotators
- WE Series TR S
- Weaver Fore & Aft
- Top Release Non
- for Rotary Fore an

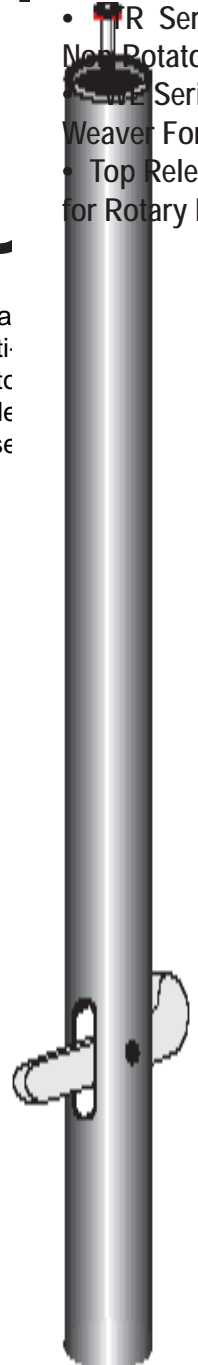

S V I Part No.	Lift Mfg. & OEM part #	Description
BH-BT-01	All	Boring Tool for Safety Leg Casing
BH-EL-66	Rotary FA2107	<b>Safety Leg:</b> 66" Stroke with 1 Flipper Lock
BH-EL-66-2	Rotary FA2317	<b>Safety Leg:</b> 66" Stroke with 2 Flipper Locks
BH-EL-67	Globe C-43860	<b>Safety Leg:</b> 67" Stroke with 1 Flipper Lock
BH-EL-67-2	Globe	<b>Safety Leg:</b> 67" Stroke with 2 Flipper Locks
BH-EL-68	Cochin/Gilbarco	<b>Safety Leg:</b> 68" Stroke with 1 Flipper Lock
BH-EL-68-2	Cochin/Gilbarco	<b>Safety Leg:</b> 68" Stroke with 2 Flipper Locks
BH-EL-69	Joyce #27753	<b>Safety Leg:</b> 69" Stroke with 1 Flipper Lock
BH-EL-69-2	Joyce	<b>Safety Leg:</b> 69" Stroke with 2 Flipper Locks
BH-EL-70	Weaver 1089300	<b>Safety Leg:</b> 69-7/8" Stroke with 1 Flipper Lock
BH-EL-70-2	Weaver	<b>Safety Leg:</b> 69-7/8" Stroke with 2 Flipper Locks
BH-GL-60	Globe C-43720	<b>Safety Leg:</b> Top Release 60" Stroke for Front Plunger
BH-GL-70	Globe C-43720-1	<b>Safety Leg:</b> Top Release 70" Stroke for Rear Plunger
BH-GL-70P	Globe C-43720-1	<b>Safety Leg:</b> Top Release 70" Stroke with Plate
BH-JD-66	Joyce #18720/21319	<b>Safety Leg:</b> with 3 Holes for 66" Rise
BH-JD-66-01	Joyce 18100	Latch and Shaft for BH-JD-66 Safety Leg
BH-LC-01	All	<b>Safety Leg:</b> Casing for 2-3/8" OD Safety Legs
BH-RO-60	Rotary FA267	<b>Safety Leg:</b> Top Release 60" Stroke 10-5/8" Moveable
BH-RO-70	Rotary FA265	<b>Safety Leg:</b> Top Release 70" Stroke 10-5/8" Stationary
BH-TR-60	Rotary FA2121	<b>Safety Leg:</b> Top Release 70" Stroke for 8-1/2" Stationary
BH-TR-66	Rotary FA2107	<b>Safety Leg:</b> Top Release with 66" Stroke
BH-TR-67	Globe C-43860	<b>Safety Leg:</b> Top Release with 67" Stroke
BH-TR-68	Cochin/Gilbarco	<b>Safety Leg:</b> Top Release with 68" Stroke
BH-TR-69	Joyce #27753	<b>Safety Leg:</b> Top Release with 69" Stroke
BH-TR-70	Weaver 1089300	<b>Safety Leg:</b> Top Release with 69-7/8" Stroke
BH-TR-75	Rotary FA2143	<b>Safety Leg:</b> Top Release 75" Stroke for 8-1/2" Moveable
BH-WE-527	Weaver AS-25527	<b>Safety Leg:</b> 72-3/4" Stroke for 7-1/2" Moveable Plunger
BH-WE-540	Weaver AS-25540	<b>Safety Leg:</b> 69-1/2" Stroke for 7-1/2" Rear Plunger
BH-WE-802	Weaver 1080802	<b>Safety Leg:</b> 77-1/2" Stroke for 10-5/8" Rear Plunger
BH-WE-803	Weaver 1080803	<b>Safety Leg:</b> 68-1/4" Stroke for 10-5/8" Moveable Plunger
BH-WE-999	Weaver 1086999	<b>Safety Leg:</b> for MC320 and MC330 12-5/8" Plungers
BH-WE-SLV		Sleeve - Call for Details
BH-RD-00		<b>Safety Leg:</b> Reduced Diameter - Call for Details

To Order Call: 800 321-8173 or 630-844-5566 / Fax: 800-899-1784 or 630-844-6770

All names, numbers, symbols and descriptions are used for reference purposes only. It is not implied that any part listed is the product of these manufacturers; however, some parts may be the actual product of these manufacturers.

# AIR CONTROL VALVES AND MUFFLERS

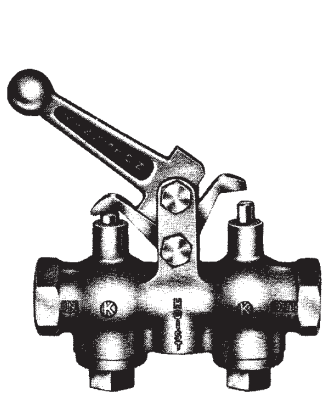

FK-302-1/2"

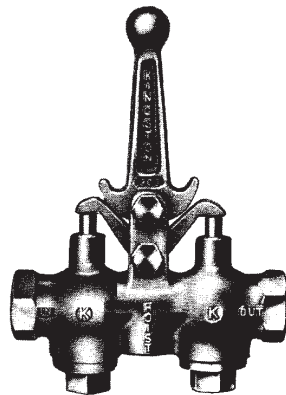

FK-303-1/2"

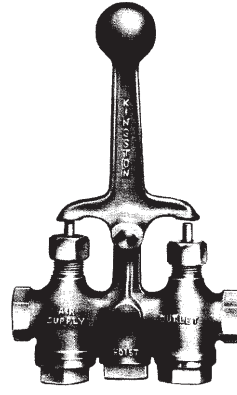

FK-300-1/2"

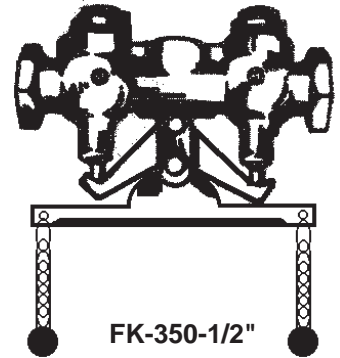

FK-350-1/2"

A full line of Kingston Hoist Air Control Valves are available. Kingston Valves offer a variety of installations and methods of safe control of air operated lifts or hoists. Valve bodies, caps and levers are of heavy cast brass. Poppet brass stems are precision machined and spring loaded to ensure tight seating. Each valve is individually tested after assembly. Figure 302-1/2" is the same as Figure 303-1/2" except it is equipped with a locking type lever. The Figure 300-1/2" old style non-locking valve. Please see the S V I Price List for a complete list of replacement parts.

Old Style Hanging Hoist Control Valve. Includes: Valve with special lever, and 15' jack chain.

**NOTE:** Parts **only** are available for Conbraco air valves. See BH-9750 series in price list.

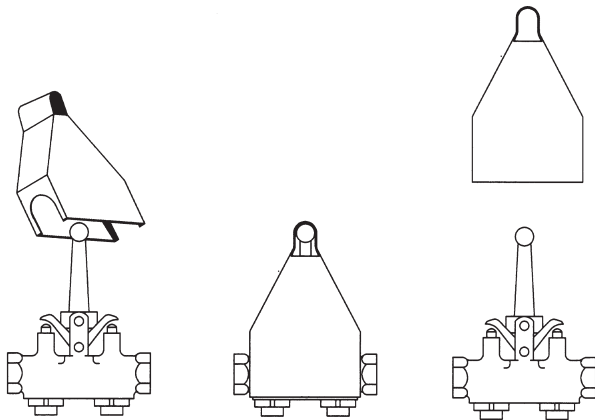

**Ideal Uses:** Great for Lift Service Professionals - slip the K-Cap on the air control valve when servicing the lift to prevent someone from accidentally operating the wrong valve. A Must for Every Safety Conscious Mechanic - with the K-Cap in use, the chances of someone inadvertently lowering or raising the lift are greatly reduced.

Each SVI K-Cap comes ready to use with an opening at the top so it can be hung somewhere near the air control valve for easy access. Every K-Cap is painted safety yellow and designed for years of trouble free use.

## Central Air Valves for Weaver lifts

The Central Air Valves are used on Weaver lifts. The BH-9625 is the locking style wall mount version for single post full hydraulic Weaver lifts (EC-184). The BH-9626 is the non-locking style wall mount version for semi-hydraulic Weaver lifts (EC-383). The BH-9627 is the floor mount version for fore and aft Weaver lifts (EC-102, EC-105, EC-107). These valves have a slightly larger body than the above style valves. They are not interchangeable with Kingston or Conbraco valves without modification of the piping.

## Air Valve Mufflers

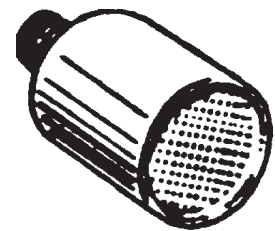

BH-9640

Weaver Style Aluminum Muffler

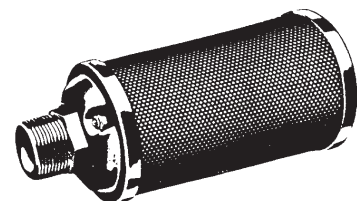

BH-9642 Metal Muffler



# 1-1/4" OIL CONTROL VALVES

The widest variety of hoist oil control valves are available from S V I. All the valves shown on this page are for 1-1/4" pipe thread. These valves are generally used for wall mount piping although some are also configured for floor mount design. Specific floor box mount oil control valves are found under the listings for each hoist manufacturer. Repair parts for all these valve are available.

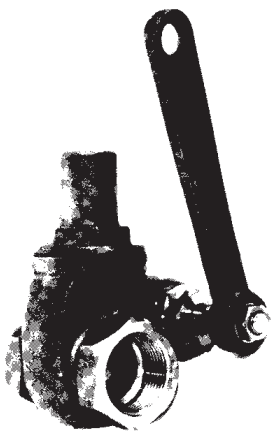

**Internal Spring  
Oil Control Valves  
(Gate Valve Style)**



**External Spring  
Oil Control Valves  
(Gate Valve Style)**

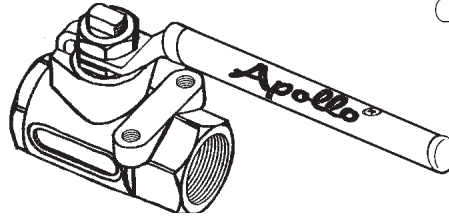

**BH-9716  
Spring Inside Handle  
(Ball Valve Style)**

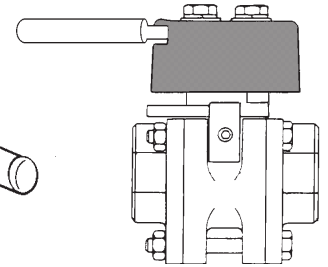

**BH-9323  
Spring Under Plastic  
Cap  
(Triangular Ball Valve)**

Oil Valve Part No.	Oil Valve Manufacturer	Style	Commonly Found on Lifts:	Identifying Features
FK-238	Morrison Bros.	External Spring		Black or Grey Handle (Silver Spring)
FK-438	Morrison Bros.	Internal Spring		Black or Grey Handle (Crown on Top)
FK-848	A.Y. McDonald	External Spring	Rotary	Green Handle (Silver Spring w/ nylon spacer)
FK-902	Milwaukee	External Spring	Globe	Red Handle (Black Spring)
BH-9323*		Triangular Ball Valve	Gilbarco/Manitowoc	Black Handle (Black Plastic Cap over spring)
BH-9323-11		Triangular Ball Valve	Gilbarco/Manitowoc	Floor Box Style
BH-9716	Apollo	Ball Valve	Western	Yellow Handle (Spring inside handle)

\*NLA - Order BH-9716. (Parts available separately for BH-9323.)

## Repair Parts

### FK-238

- FK-238-02 Cap
- FK-238-03 Fulcrum Lever
- FK-238-04 Fulcrum Shaft
- FK-238-05 Concave Disc
- FK-238-06 Convex Disc
- FK-238-07 Packing Nut
- FK-238-08 Stuffing Box Nut
- FK-238-09 External Spring
- FK-238-10 Handle
- FK-238-11 Gasket
- FK-238-12 Lock Nut
- FK-238-13 Nitrile Seal
- FK-238-14 Lock Washer

### FK-438

- FK-438-02 Cap
- FK-238-03 Fulcrum Lever
- FK-238-04 Fulcrum Shaft
- FK-238-05 Concave Disc
- FK-238-06 Convex Disc
- FK-238-07 Packing Nut
- FK-238-08 Stuffing Box Nut
- FK-438-09 Internal Spring
- FK-238-10 Handle
- FK-238-11 Gasket
- FK-238-12 Lock Nut
- FK-238-13 Nitrile Seal
- FK-138-14 Lock Washer
- FK-438-15 Spring Guide

### FK-848

- FK-848-04 Repair Kit
- FK-848-09 Spring
- FK-848-10 Handle

### FK-902

- FK-902-02 Cap
- FK-902-03 Disc Set
- FK-902-04 Lever
- FK-902-05 Spring
- FK-902-06 Stem Nut
- FK-902-07 O-ring
- FK-902-08 Stem
- FK-902-09 Handle & Nut
- FK-902-10 Handle

### BH-9323

- BH-9323-01 Spring
- BH-9323-02 Cover (Wall Mount)
- BH-9323-03 Handle (Wall Mount)
- BH-9323-04 Mandrel Assy.
- BH-9323-05 Flat Washer
- BH-9323-06 Set Screw
- BH-9323-07 Shear Proof Pin
- BH-9323-10 Valve Body
- BH-9323-12 Handle (Floor Mount)
- BH-9323-13 Cover (Floor Mount)
- BH-9323-14 Ball Valve Stem
- BH-9323-15 Dynaquip Ball
- BH-9323-20 Seal Kit

### BH-9716

- BH-9716-01 Handle Assy.
- BH-9716-02 Seal Kit

To Order Call: 800 321-8173 or 630-844-5566 / Fax: 800-899-1784 or 630-844-6770

All names, numbers, symbols and descriptions are used for reference purposes only. It is not implied that any part listed is the product of these manufacturers; however, some parts may be the actual product of these manufacturers.

# AIR/OIL TANKS FOR FULL HYDRAULIC LIFTS

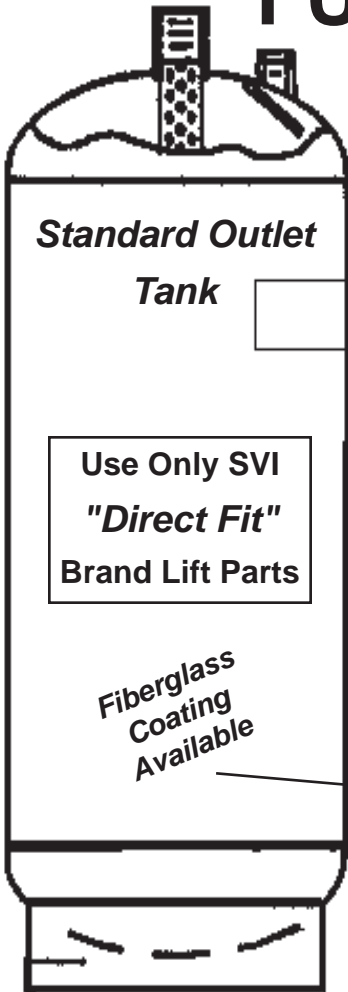

- \* Fit all Types of Lifts
- \* Manufactured to A.S.M.E. Code
- \* Registered with the National Board
- \* Tanks Come Standard with a Base Ring
- \* Optional Fiberglass Coating Available
- \* Low Oil Lock Floats Available

**SPECIFICATIONS**

A.S.M.E. CODE SECT. VIII DIV. 1

PRESSURE: 200 PSI AT 450° F

MINIMUM: -20° F AT 200 PSI

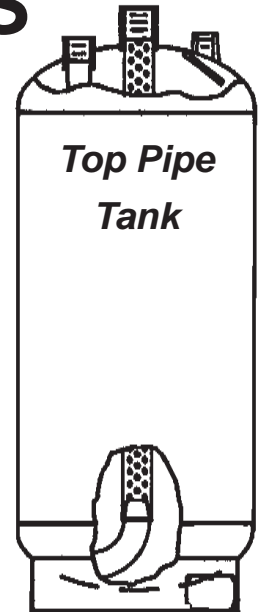

The superior design and precision fabrication of Hoist Air/Oil Tanks built for S V I ensures quality performance. All Bottom pipe tanks come standard with a base ring and perforated tube for low-oil lock (an optional float is available). Top outlet tanks include inner piping for outlet from the top of the tank. Standard finish is lead oxide primer, with an optional fiberglass coating available at a small additional charge. Blanket orders are welcome.

### Fiberglass Coating Option

Fiberglass coating for in-ground lift components is the best protection against corrosion. We use a durable 1/8" thick coating that won't chip or peel. The S V I fiberglass coating protects through its electrical insulating properties. It insulates the tank from electrolysis. Because it is bonded directly to the outer surface, it keeps out moisture and bacteria, providing many years of protection.

### Other Options:

**Low Oil Control Floats:**

SVI offers magnesium low oil control floats which ride inside the perforated tube standard on all S V I tanks. The float will seat at the tank bottom outlet seat if the oil level is low, thus preventing air from entering the cylinder.

BH-9810	Low Oil Float with 1/4" - 20 threads
BH-9811	Low Oil Float with 8-32 threads
BH-9811-01	Eye hook for BH-9811 Float
BH-9812	Ext. Low Oil Lock Complete

**Zinc Anodes for Corrosion Control**

Zinc Anodes are designed to attract electrolysis and keep it away from the hoist and tank. Anodes slowly decay over time sparing the important equipment as they go. 30 lb. anodes will last 5 years or longer. It is connected to the bottom of the tank or hoist casing and is buried below the tank.

BH-9830-15	15 lb. Anode
BH-9830-30	30 lb. Anode

**Pipe and Tank Wrap Tape**

Pipe and Tank wrap tape protects all buried, submerged or exposed metal pipe, casings, and tanks. The adhesive is composed of a special synthetic rubber base to assure added protection and life. 100% vinyl jacket offers excellent resistance to saltwater, alkalies, acids, oils, bacteria and fungus.

BH-9900-02	2" x 100' Tape Roll
BH-9900-04	4" x 100' Tape Roll

## 5 YEAR LIMITED WARRANTY

Our air/oil tanks are warranted to be free from defect in material and workmanship for five years. We will replace free of charge, F.O.B. factory, any tank we may furnish which, in our opinion, proves to be defective in material or workmanship, provided the tank has been properly installed and operated under normal conditions. For warranty consideration the tank data plate and that portion of the tank body underneath the plate must be flame cut and returned to S V I along with a letter of explanation and detail. Under no circumstances will we recognize claims for labor charges or consequential damages, our liability being limited strictly to the replacement of the tank that has proven, according to our judgement, to be defective. We do not authorize any person or persons to assume for us any other warranty liability in connection with the sale of our tanks.

**To Order Call: 800 321-8173 or 630-844-5566 / Fax: 800-899-1784 or 630-844-6770**

All names, numbers, symbols and descriptions are used for reference purposes only. It is not implied that any part listed is the product of these manufacturers; however, some parts may be the actual product of these manufacturers.





# AIR/OIL TANKS FOR FULL HYDRAULIC LIFTS

S V I Tank #	Available Oil Capacity	Tank Width	Tank Height	Overall Length*	Approx. Shipping Weight	used with lifts:
BH-9801 (standard) BH-9801-T (top pipe)	36 35	14" 14"	56" 60"	63" 63"	110 lbs. 110 lbs.	Single Post 10-5/8" or twin 7-1/2" posts
BH-9802 (standard) BH-9802-T (top pipe)	43 42	16" 16"	52" 55"	58" 58"	128 lbs. 128 lbs.	Twin Posts with 8-1/2" cylinders and some 10-5/8" single post lifts.
BH-9803 (standard) BH-9803-T (top pipe)	51 52	14" 14"	81" 84"	87" 86"	127 lbs. 127 lbs.	Narrow Tank for Rotary AC60H.
BH-9804 (standard) BH-9804-T (top pipe)	63 61	16" 16"	74" 77"	81" 81"	157 lbs. 157 lbs.	Twin Post with two 10-5/8" cylinders.
BH-9805 (standard) BH-9805-T (top pipe)	47 47	14" 14"	74" 72"	81" 76"	115 lbs. 115 lbs.	Twin Posts with dual 8-1/2" cylinders or 7-1/2" front and 10-5/8" rear cylinder.
BH-9806 (standard) BH-9806-T (top pipe)	80 87	20" 20"	63" 67"	70" 71"	203 lbs. 203 lbs.	Twin Post with 10-5/8" and 12-5/8" cylinders

\* Overall Length includes tank body plus base ring and top fitting.

Tank Kits: Add "C" to the part number for a Tank Kit complete with Safety Bleeder-Style Fill Plug with Gauge and Low Oil Float.

Fiberglass Coating: Add "FG" to the part number for a fiberglass coated tank.

## OEM TANK CROSS REFERENCE INFORMATION

S V I Tank Part #	OEM and OEM Part Number		OEM Cross Reference to Lift Models
BH-9801 Series	Globe Rotary Weaver	C43888-1 FA125 AS28258	FS-27 FP48H, PF10H, DRT10H, WABU10H, PFV10H, QL10H, RBU10H, 35HR EC-184B, EC-881, EC-284, EC500, 400, , 600, EC100/102, EC-292
BH-9802 Series	Gilbarco Globe Rotary	R18219-G1 C43888-2 FA123	A-1AA3A, Series Single Post Lifts, A-12D3A Series Two Post Lifts MP28-A, MP810-A, FS-10-BS, FSR-28, FSN-28, FS-28, PD-28L, P-28 DTO28H, 28HR, PT20H, WABU28H, OL28H, WRP90, PFP26H, AR28H
BH-9803 Series	Rotary Western	FA128 M730	AC60H AC-810
BH-9804 Series	Globe Rotary Weaver Western	C43888-3 FA126 1080280 M735	MP-210A, SHMP-210A AT70H, T210 Series, 710MLS EC-105 AC-1010
BH-9805 Series	Rotary Weaver Western	FA127 1080279 M725	AP50H, AP52H EC-107 ( <b>BH-9805-T cannot be used in this application</b> ) AC88, WP-2, XLA, XLH
BH-9806 Series	Rotary	FA129	T212H, T212LS, T212DS, AT1012H

To Order Call: 800 321-8173 or 630-844-5566 / Fax: 800-899-1784 or 630-844-6770

All names, numbers, symbols and descriptions are used for reference purposes only. It is not implied that any part listed is the product of these manufacturers; however, some parts may be the actual product of these manufacturers.

# GLAND RING IDENTIFICATION

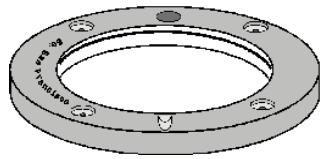

Lift Manufacturer: **Cochin**  
 O.E.M. Part # B-20643, A-20656  
 Plunger Diameter 8-5/8", 10-5/8"  
 Material: Aluminum  
 Ident. Features: "South San Francisco" printed on Gland  
 BH-1790G - 8-5/8"  
 BH-1737G - 10-5/8"

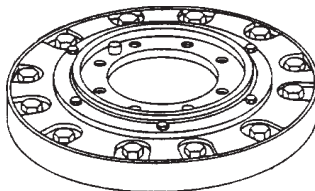

Lift Manufacturer: **Gilbarco/Manitowoc**  
 O.E.M. Part # T-13943-02, T-13943-03  
 Plunger Diameter 10-5/8"  
 Material: Aluminum  
 Ident. Features: Steel Wiper Ring Retainer  
 fits inside Gland Ring  
 BH-9322-02 - Full Hyd.  
 BH-9321-04 - Semi Hyd.

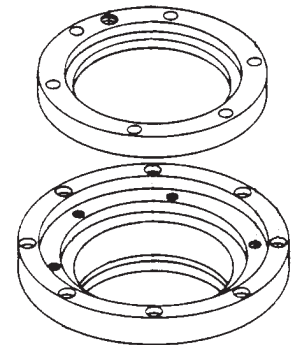

Lift Manufacturer: **Gilbarco/Manitowoc**  
 O.E.M. Part # T-13911-02  
 Plunger Diameter 8-5/8"  
 Material: Aluminum  
 Ident. Features: Steel Wiper Ring Retainer  
 fits inside Gland Ring  
 S V I Gland Part # BH-9313-33

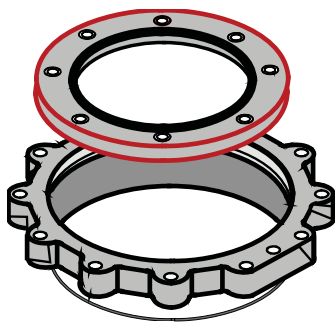

Lift Manufacturer: **GlobeWayne**  
 O.E.M. Part # B-35054, B-35055  
 Plunger Diameter 10-5/8"  
 Material: Cast Iron  
 Ident. Features: Has tag with a K# (38K-xxx) and Alan Head bolts

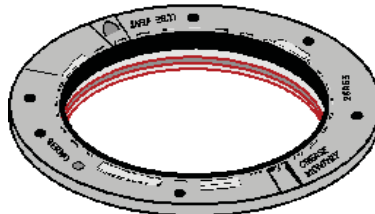

Lift Manufacturer: **Joyce**  
 O.E.M. Part # 24435, 23963  
 Plunger Diameter 7-1/2", 10-1/2"  
 Material: Cast Iron  
 Ident. Features: "SERNO", grooved for oil overflow vent - lube monthly  
 BH-9515-20, BH-9520-10

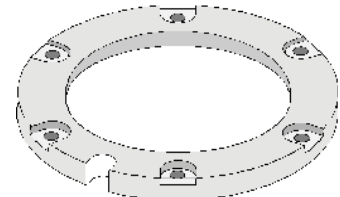

Lift Manufacturer: **Rotary**  
 O.E.M. Part # JG620, JK622  
 Plunger Diameter 8-5/8", 10-5/8"  
 Material: Cast Aluminum  
 Ident. Features: 6 Bolts and Bleeder Notch

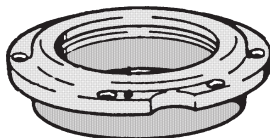

Lift Manufacturer: **Weaver**  
 O.E.M. Part # M-2100, M-2114  
 Plunger Diameter 7-1/2", 10-5/8"  
 Material: Steel  
 Ident. Features: Has Socket Head Capscrews  
 One Piece Gland/Bearing

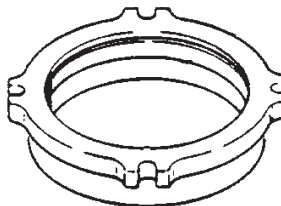

Lift Manufacturer: **Weaver**  
 O.E.M. Part # M-1551, M-1323, M-1402, M-1386  
 Plunger Diameter 7-1/2", 10-5/8"  
 Material: Steel  
 Ident. Features: Fits over 4 Studs on Casing For Fore and Aft Lifts  
 BH-9670-06, BH-9670-01, BH-9667-24, BH-9667-29

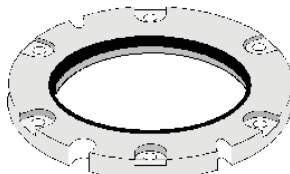
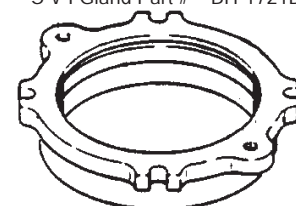

Lift Manufacturer: **Western**  
 O.E.M. Part # U-220  
 Plunger Diameter 8-1/2"  
 Material: Cast Aluminum  
 Ident. Features: 6 Bolts, Bleeder Plug plus two removal grooves

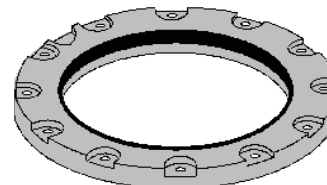

Lift Manufacturer: **Western**  
 O.E.M. Part # U-205  
 Plunger Diameter 10-5/8"  
 Material: Cast Aluminum  
 Ident. Features: 12 Bolts, 1 Bleeder Plug

# To The 3<sup>rd</sup> Power

Baltimore  
Chicago  
Los Angeles



3X the convenience  
3X the experience  
3X the inventory

***You need this . . .***

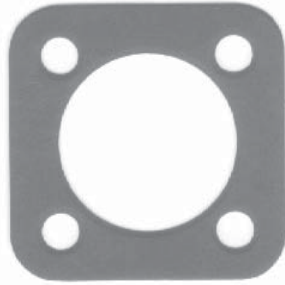

You don't have the part number, but SVI sales professionals can still find the part. Offering over 12,000 parts like this gasket, our sales pros are cross-trained on nearly every in-ground and surface mount lift in use today. Convenience like this has made SVI the leader in lift repair parts throughout North America. From three **"Ready Ship"** warehouses to producing obsolete parts - SVI has earned the reputation as your **Direct Fit** source.

-----  
**SVI is your Answer!**



**SVI International, Inc.**  
**LIFT REPAIR PARTS**

**BALTIMORE - CHICAGO - LOS ANGELES**

Main Office: 101 W. Illinois Ave. • Aurora, Illinois 60506 • 800-321-8173 • Fax 800-899-1784