

Model DTO28H Mark VI

Drive-Thru / Drive-Over

Two-Plunger Frame Pick-Up Lift

Capacity 8,000 lbs.

Model FJ696 Optional Pickup and Van Adapter

Installation, Operation and Maintenance Instructions

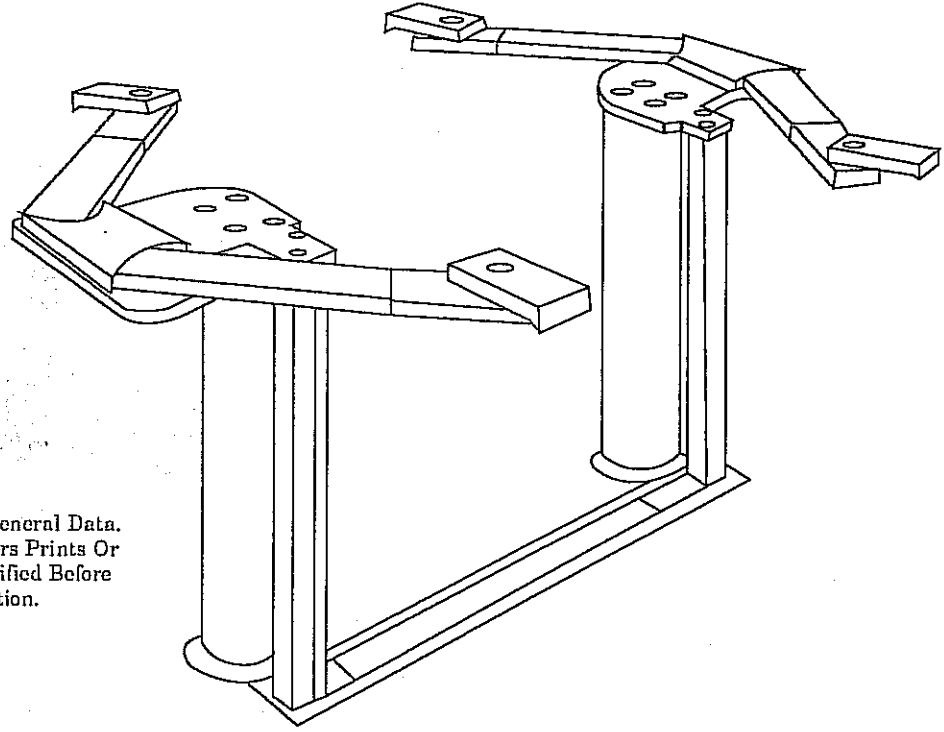

These Instructions Contain General Data. Any Deviation From Customers Prints Or Specifications Should Be Clarified Before Proceeding With Lift Installation.

CHECK SHIPMENT against Bill of Lading and Material List. Enter all claims for damage or shortage at once with delivering carrier.

MATERIAL LIST

Description of Articles		Parts Box Contents			
2	8 1/2" Hydraulic Jacks	1	Wheel Dish	8	3/4" x 2 1/2" Cap Screws
2	Superstructure Yokes	4	Swivel Adapters	8	3/4" Lock Washers
4	Arms	1	Oil Valve	8	1/2" x 1 1/2" Cap Screws
1	Air-Oil Tank	1	Air Valve	4	1/2" x 2 1/2" Cap Screws
1	Housing Cover	1	Muffler	12	1/2" Hex. Nuts
1	Equalizer Assembly	1	Oil Gauge		
1	Parts Box	1	Low Oil Control		

ROTARY LIFT
A **DOVER** INDUSTRIES COMPANY

ROTARY LIFT
A Dover Industries Company
P.O. Box 30205, Airport Station
Memphis, Tennessee 38130
Phone toll-free: 1-800-445-LIFT (5435)
(901) 345-2900
FAX: (901) 332-4260

For Export
ROTARY LIFT EXPORT COMPANY
200 Executive Drive, Suite 320
West Orange, NJ 07052
(201) 325-3838
Telex # 13-8693

For Canada:
DOVER CANADA
31 Progress Court, Unit 10
Scarborough, Ontario, Canada M1G3V5
(416) 439-9713
Telex # 085-25468

INSTALLATION INSTRUCTIONS

- LIFT LOCATION:** Check architect's layout if available. Lay out lift as shown in Fig. 1. The 5'-6" centerline to side and 12'-0" centerline to front and rear dimensions should be maintained to provide adequate working space. The minimum ceiling clearance should be 12'-6" from floor to underside of ceiling joists and other obstructions in the lift area. 24'-0" length bay recommended. Other lengths may be used, provided ample clearance is maintained at ends of lift.

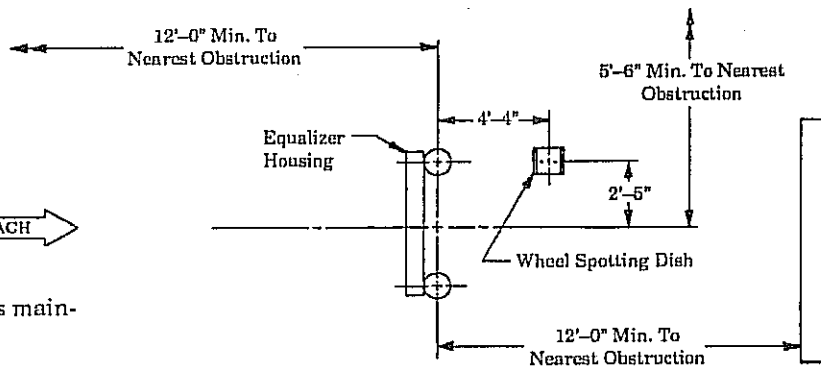

Fig. 1

Important: Test soil to determine corrosive characteristics. Take the necessary measures to protect in-ground equipment with one of the many cathodic protection systems. Failure to provide underground protection when indicated by soil test could cause oil leaks to develop in the hydraulic system, resulting in costly repairs or making the equipment inoperative and unsafe.

- EXCAVATION:** Excavate hole to dimensions shown in Fig. 2. If oil tank is to be installed underground, but not in same excavation as jacks, the tank hole should be at least 2'-0" in diameter and 7'-0" deep. Dig trenches 12" deep for air and oil lines between lift tank and control valve location. Locate control valves to give the operator an unobstructed view of the lift area. Pour concrete slab in bottom of hole as shown in Fig. 2. Be sure distance from

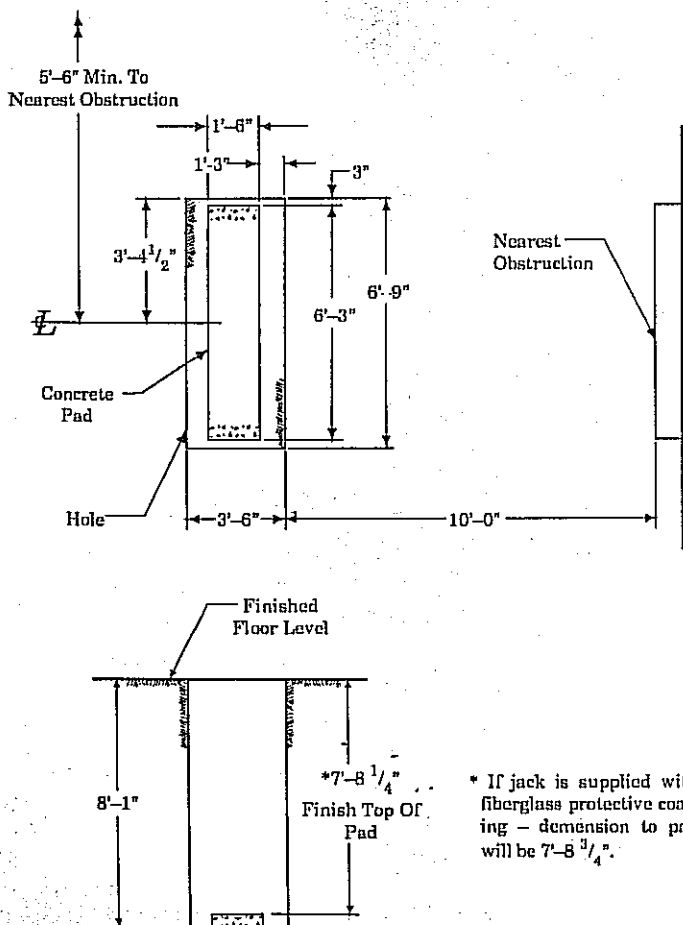

Fig. 2

top of slab to finished floor grade is 7'-8 1/4" (7'-8 3/4" if jacks have fiberglass coating). Allow concrete to set before installing jacks!

- LIFT SETTING:** Place jacks on floor with brackets facing up. Check housing for damage. (IF HOUSING IS BENT, STRAIGHTEN AND BRACE BEFORE INSTALLATION.) Place housing on jack brackets and bolt in place with 1/2" x 1 1/2" cap screws and nuts. Do not remove or loosen any of the bearing guide bolts.

Remove plunger shipping straps. Strap retainers serve as sling lugs for attaching chain hoist. Chain hoist must have capacity of 2,000 lbs. with a clear swing of 9'-0". Rig slings for each jack, Fig. 3, and lower assembly into hole. Do not swing assembly by equalizer housing because housing may become misaligned. Center jacks on concrete pad. Be sure equalizer housing is to the approach side of lift as shown in Fig. 1.

Shim under each jack until top of protector ring is flush with finished floor level. See Fig. 4. It is imperative that both jacks be set at same elevation regardless of floor slope or other factors. **Shore Lift Securely!** Plumb and level by placing spirit level on top of plunger. **Do Not** plumb or level off jack outer casing or protector ring. See Fig 5.

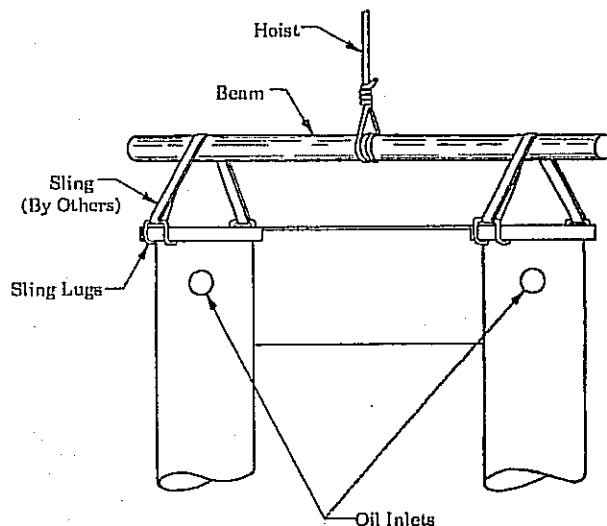

Fig. 3

See Fig. 4. Mark points "A" at centerline at top of jack protector rings and measure down 91" to points "B" on centerline of each jack casing. Measure diagonals. They **Must** be equal for rigid equalizer to work properly. If diagonals are not equal, loosen housing to jack attachment bolts and adjust for proper alignment. **Hold 57 1/2" Jack Centers.**

After jacks are plumb and level, pour concrete 3" deep around jacks. Recheck plungers for plumb and elevation before concrete hardens. See Fig 4 & 5.

Position concrete blocks or other suitable support 7'-0 1/2" below grade to support tank. Brace top of housing to prevent distortion during concrete pour.

For backfill use only clean sand. Never use cinders or corrosive material.

CAUTION: Do not use a mechanical tamper. This could cause housing side sheet to bend inward, "HAND TAMP ONLY."

Each Plunger Must Be Filled With Clean Sand To Provide Sufficient Lowering Speed.

After filling each plunger half way, pour in 1 gallon of new hydraulic oil in each plunger. Finish filling plungers and pour in another gallon of new hydraulic oil per plunger.

4. **TANK LOCATION:** Underground installation of tank is recommended as shown in Fig. 6. Tank may be located above ground as shown in Fig. 7. Be sure tank installation meets requirements of local codes.

5. **UNDERGROUND TANK INSTALLATION AND PIPING:** Refer back to section 1, paragraph 2 for corrosion protection. All underground pipe and fittings should be double wrapped with a 10 mil. tape. See Fig. 6. Provide tank fill assembly consisting of 2" x 25" long pipe, 2" coupling. Factory recommends Schedule 40 pipe and standard fittings. **BE SURE** all piping conforms to local and state codes. Use a good joint sealant because air joints are difficult to seal. Wash out all pipe with a solvent and blow dry with air. Set tank in hole holding top of fill coupling at floor level. Backfill and tamp around tank. Use 1/2" air line from air valve to tank and 1 1/4" pipe for all oil line piping. Be sure to center "Tee" in oil supply line between jacks. Provide 3/4" pipe from compressor main line to air valve. Tap main line from top side for moisture-free air to valve. Locate valves about 40" above floor.

After piping is completed, continue backfill, tamping solid and check jacks for plumb and elevation.

DO NOT COVER ANY PIPING OR JOINTS before testing.

DO NOT install low oil control at this stage. Float will be damaged during initial filling and bleeding process.

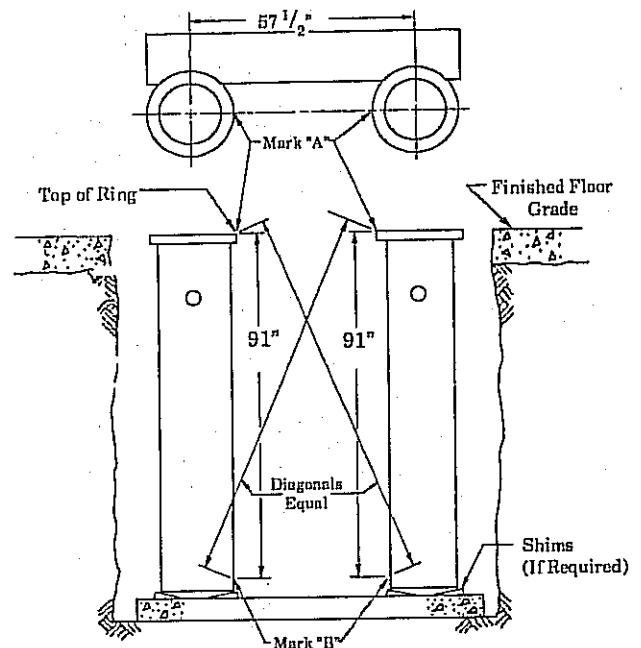

Fig 4

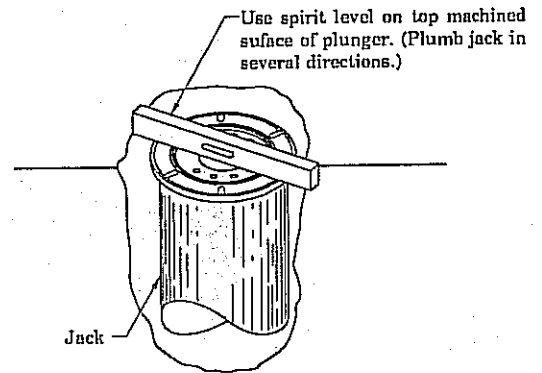

Fig. 5

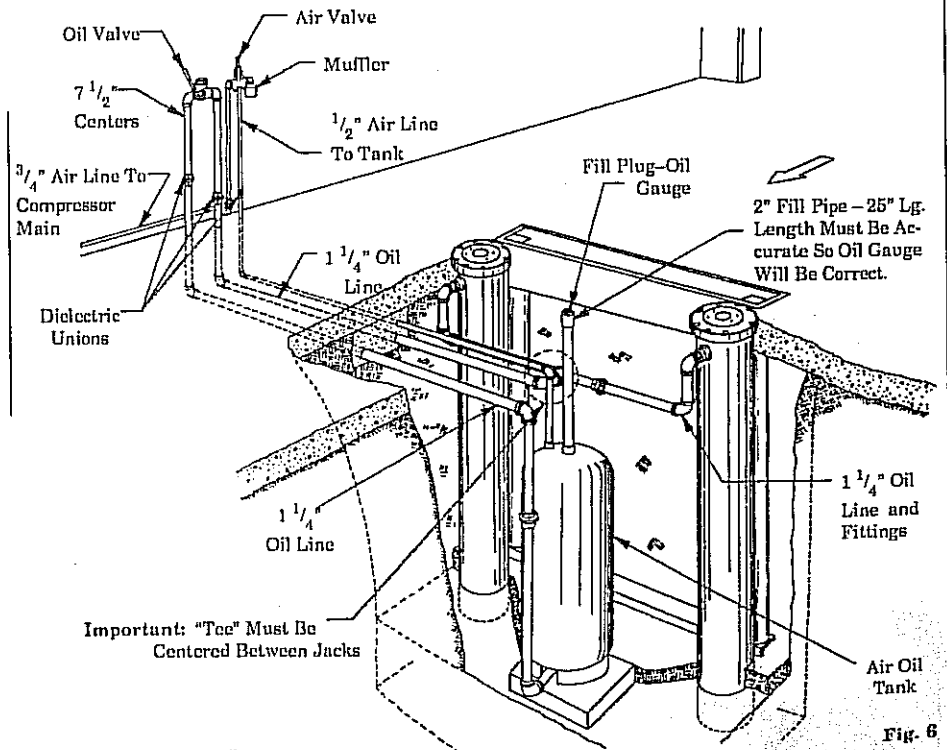

Fig. 6

6. **ABOVE GROUND TANK INSTALLATION AND PIPING:** See Fig. 7 for pipe sizes and the above paragraph for cleaning instructions. Refer to Fig. 6 for oil piping to jack inlets.

Note: Above ground tank installation requires a shorter fill plug oil gage assembly. Order a FA123-15.

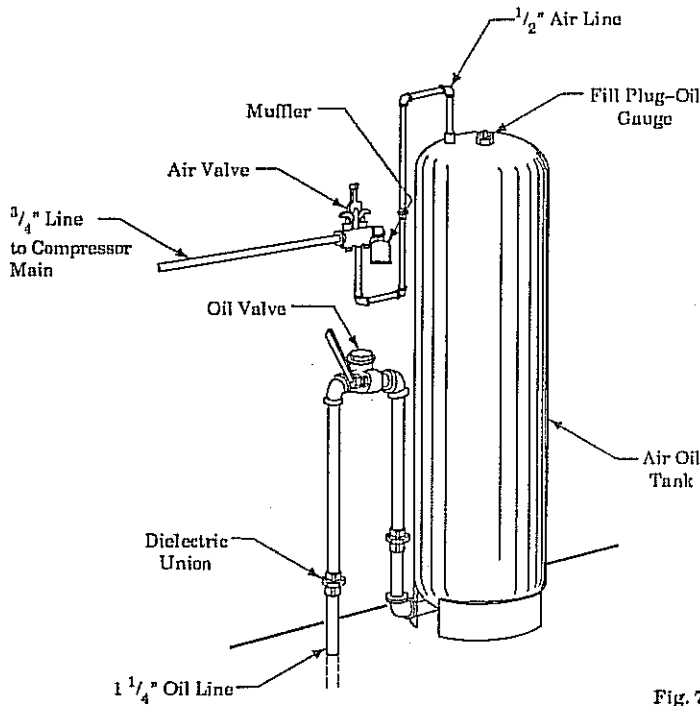

Fig. 7

CAUTION: Do Not test or attempt to operate before filling with oil.

7. **OIL FILLING:** Factory recommends using an oil that has a viscosity grade of 46 (SAE 20) with anti-foam, anti-rust, anti-oxidation and anti-air entrainment additives. System capacity of the model DTO28H is 62 gal. Do Not use "hydraulic fluids" as they may foam when used in conjunction with air pressure.

- A. Fill tank with oil (approximately 42 gallons). Install and tighten fill plug and fill plug vent screw, Fig. 9.
 B. Pressurize tank with air by locking air valve handle in position opposite muffler and fully charge tank. Open oil valve and slowly admit oil to jacks.

CAUTION: Do not let plungers extend more than two feet during filling and bleeding operations.

- C. Open air bleeders in jacks 2 full turns. See Fig. 8. Close bleed screws when constant stream of oil appears.
 D. Lock air valve with handle in the position toward muffler. Exhaust all air from tank. Lower lift to floor.
 E. Use a screwdriver to manually open fill plug vent screw 3 full turns, Fig. 9. If you hear or feel air escaping "STOP", the system is still pressurized. Repeat step "D".
 F. **Be sure** all air pressure has bled off before attempting to remove fill plug vent screw from fill plug.
 G. Use a 3/8 inch drive pull bar to manually remove fill plug assembly. Do Not use impact wrench.
 H. Add oil as required to bring to gauge level.
 I. Install low oil control, as shown in Fig. 9.

- J. Coat the fill plug threads with anti-seize compound to retard rusting. Reinstall plug in coupling. **Do Not** coat, dope or tape fill plug vent screw threads. Reinstall fill plug vent screw.

Note: Jacks may be damaged if lift is operated without being fully bled of air.

8. **TESTING:** Tighten tank plug and air bleeders. Raise jacks to full travel, keeping air and oil valves open until air compressor shuts off. Close oil valve and return air valve handle to neutral position. Check all pipe joints for leaks.

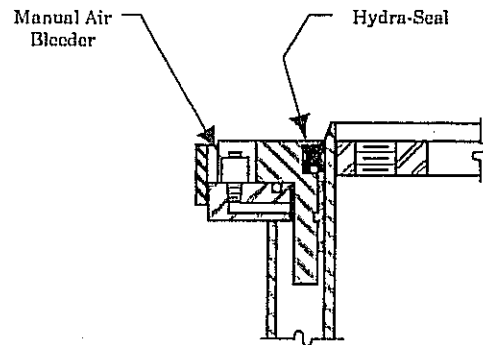

Fig. 8

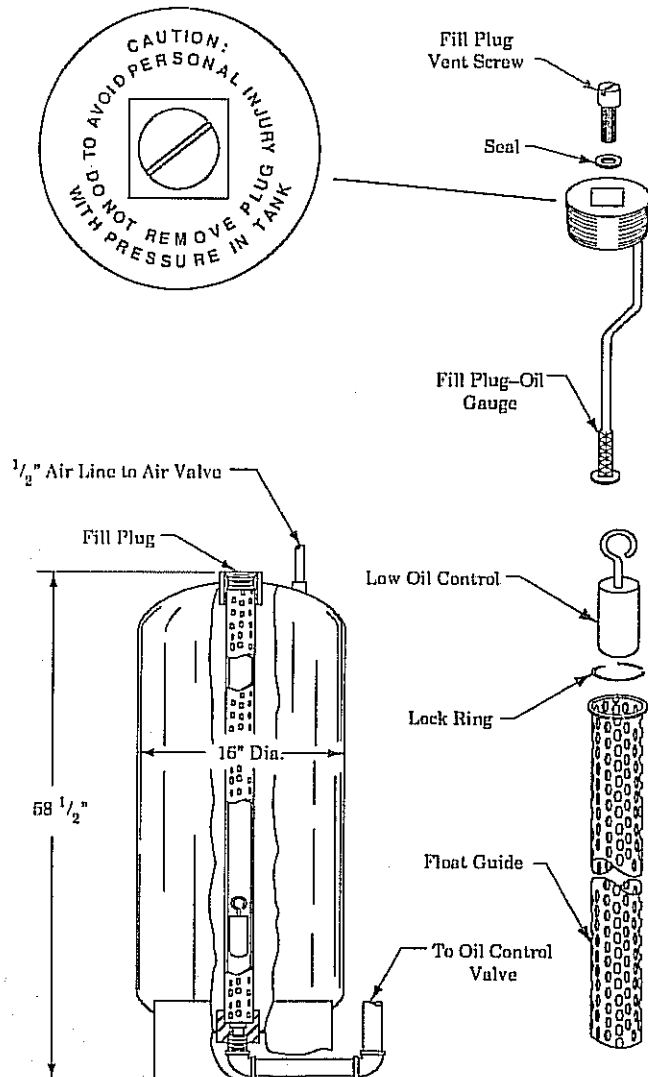

Fig. 9

Check air valve caps for tightness. Do not use pipe compound on caps.

9. **FINAL BACKFILL AND CONCRETE WORK:** Complete backfill to within 6" of top of jack protector ring. Backfill and tamp pipe trench. Check and straighten protector ring if dented during shipment. Make final elevation and plumb checks, Fig 10. Jack protector rings must be at floor level. Improper setting may cause lift lock to malfunction. Bend sling lugs down below finished floor level. Reinforce top of equalizer housing with wood spacers. Pour concrete floor, being careful not to run concrete into box or around packing gland. Trowel smooth and allow to harden.

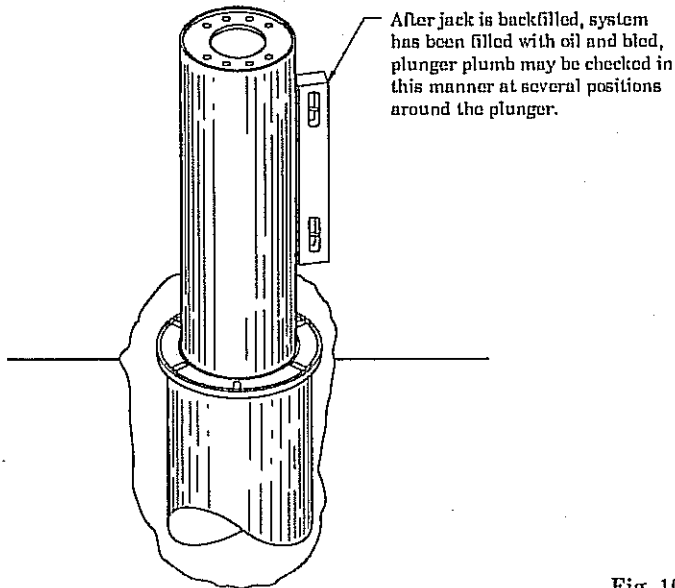

Fig. 10

10. **SUPERSTRUCTURE AND EQUALIZER:** Install yokes with $\frac{3}{4}$ " x $2\frac{1}{2}$ " lg. cap screws and lock washers. Raise jacks to full rise. Pull equalizer frame up and support on locking latches while bolting to superstructure. Bolt equalizer to yoke with $\frac{1}{2}$ " x $2\frac{1}{2}$ " bolts and nuts. Tighten bolts. Equalizer frame should be centered fore and aft in housing. If necessary, shim between yoke and equalizer attachment plate to center equalizer frame in housing.

Check equalizer slider clearance with housing end. Raise lift to full rise. Pry frame to one side until slider is in contact with housing end. Other slider should clear housing by $\frac{1}{16}$ " (max.). Adjust slider if required (keeping frame centered in housing) by adding or subtracting shims. See Fig. 11.

Remove braces from top of equalizer housing. Bolt cover plate to housing with two $\frac{5}{16}$ " Hex Nuts. Clean and lubricate tongue and groove area of yoke and arms as well

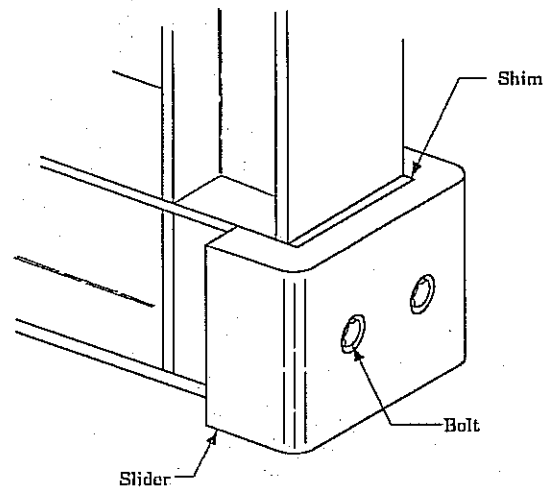
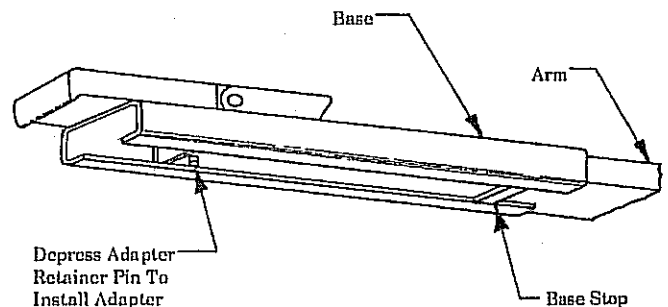
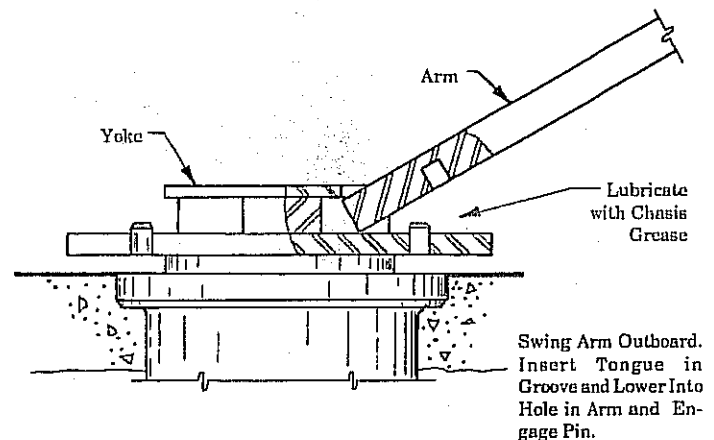

Fig. 11

as pin area on yoke. Attach arms and install (4) swivel adapters per Fig. 12.

Important: For maximum reach and versatility, install the (2) long sleeve adapters on the rear arms.

Be sure adapter retainer pin is not rusted or painted in the recessed position. It must limit the adapter extension on the arm.



For Maximum Reach Install Adapters as Illustrated

Fig. 12

11. **FINAL TOUCHES:** Lag wheel spotting dish to floor using two $\frac{3}{8}$ " Phillips Red Head anchor sets or equivalent. See Fig. 1 for dimensions. Raise lift and clean sand and dirt from plunger and lift area. Oil plungers lightly. 

OPERATING INSTRUCTIONS

WARNING: To avoid personal injury and/or property damage, permit only trained personnel to operate lift. After reviewing these instructions get familiar with lift controls by running the lift through a few cycles before loading vehicle on lift.

1. Lift must be fully lowered and service bay clear of all personnel before the vehicle is brought on lift. Position swinging arms to clear vehicle tire when it is driven into bay. Do not drive vehicle into lift arms and adapter.
2. Spot vehicle over lift with left front wheel in proper spotting dish position, Fig. 13.
3. **Loading:** Swing arms under vehicle and position adapters at vehicle manufacturer's suggested pick-up points, Fig. 14. Use intermediate, high step or optional adapters for under chassis clearance when required, see page 8.

WARNING: Before attempting to lift any vehicle, be sure that:

- A. Individual axle vehicle weight does not exceed one-half lift capacity.
- B. Adapters are in secure contact with frame at vehicle manufacturer's recommended pick-up points.

Typical Wheeling Spotting Positions

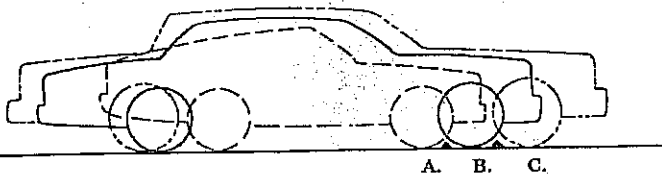

- | | | |
|--|---|--|
| <p>A. Less than 105" wheel base - position left front wheel on approach side of wheel dish.</p> | <p>B. 105" thru 127" wheel base - position left front wheel in wheel dish.</p> | <p>C. Larger than 127" wheel base - position left front wheel just forward of wheel dish.</p> |
|--|---|--|

WARNING: Most speciality or modified vehicles cannot be raised on a frame engaging lift. Contact vehicle manufacturer for raising or jacking details.

Fig. 13

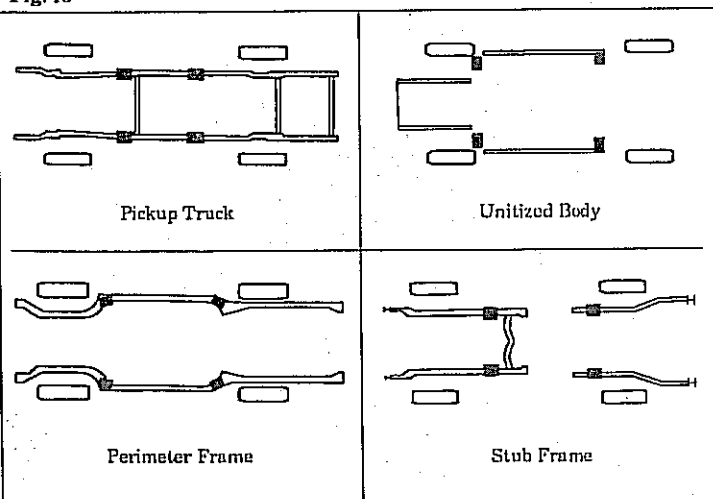

Typical Lifting Points:
Refer to manufacturer's suggested pick-up points.

Fig. 14

- C. Vehicle is stable on lift and neither front nor "tail" heavy.
- D. Adequate overhead clearance is available.

4. To Raise Lift:

- A. Lock air valve with handle in position opposite muffler and fully charge tank.
- B. Slowly open oil valve to raise vehicle until tires clear the floor.
- C. Stop and check adapters for secure contact at vehicle manufacturer's suggested pick-up points.
- D. Lower vehicle and reposition adapters and/or vehicle if required and repeat step "C".
- E. Open oil valve to continue to raise to desired height **only** if vehicle is secure.
- F. Locking Latches automatically rotate to lock position at full rise.
- G. Before going under the vehicle, check again to be sure all four adapters for secure contact at manufacturer's suggested pick-up points.
- H. Repeat complete Item 4 procedure if required.

Note: With some vehicles, the removal (or installation) of components may cause a critical shift in the center of gravity, and result in raised vehicle instability. Refer to the vehicle manufacturer's service manual for recommended procedures when performing these services.

CAUTION: Stand clear of lift when lowering.

5. To lower lift:

- A. Remove all tools or other objects from lift area.
- B. Resetting Locking Latches: Raise lift to full rise, rotate latches to reset position, Fig. 15.
- C. Lock air valve with handle in the position toward muffler. Exhaust all air from tank.
- D. Open oil valve to lower vehicle.
- E. Fully lower lift and adapters.
- F. Remove adapters from under vehicle and position swing arms to clear vehicle's tires before removing the vehicle.

6. If lift is not operating properly, **Do Not** use until adjustment or repairs are made by qualified automotive lift representative.

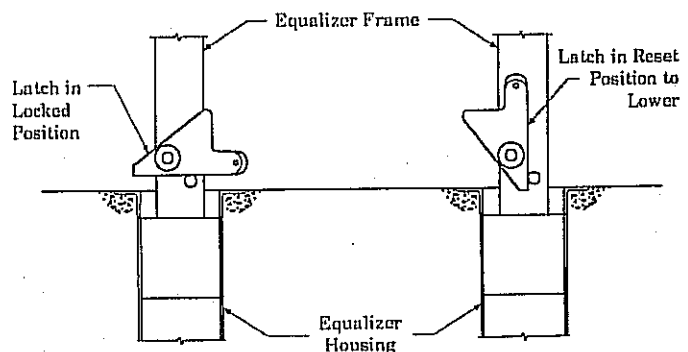

Fig. 15

SAFETY TIPS

- Never allow unauthorized persons to operate lift.
- Thoroughly train new employees in the use and care of lift.
- If lift speeds up near full rise, lift is low on oil. See maintenance tips section of this booklet.
- Capacity of lift is 8,000 lbs. (2,000 lbs. per adapter). Capacity should not be exceeded.
- Refer to other safety related literature in the Owners Package.
- Swivel Adapters should engage vehicle uniformly and securely at all four contact points. Refer to Operating Instructions on page 6.
- Remove passengers before raising vehicle.
- Keep area around lift clean of tools, debris, grease and oil.
- Oil valve is designed to spring return to close NEVER wedge or lock oil valve open to operate lift.

 Pentax

MAINTENANCE TIPS

WARNING: If you are not completely familiar with automotive lift maintenance procedures **STOP:** contact factory for instructions.

TO AVOID PERSONAL INJURY, Permit only qualified personnel to perform maintenance on this equipment.

- Never: Operate lift with equalizer disconnected.
- Never: Overload lift. See capacity nameplate located on superstructure.
- Never: Exceed 200 p.s.i. operating pressure. Lift is designed to raise capacity load at 150 p.s.i.
- Never: Wedge or lock oil control valve in open position.
- Never: Strike plunger with tools. Sharp edges may result in seal damage. If leak occurs, inspect plunger for sharp edges and sand smooth with fine emery paper before replacing seal.
- Always: Keep locking latch free and oiled.
- Always: Keep all bolts tight.
- Always: Keep superstructure clean.
- Daily: Drain air compressor tank to eliminate accumulation of water. (Do not rely on automatic drain.) Excessive water is harmful to lift system.
- Monthly lubricate tongue, groove and pivot pin area on yoke and arms for easy adjustment, Fig. 12.

Check Fluid Level In Tank If One Of The Following Conditions Exists:

- A. Lift not raising to full travel. Usually caused by a low oil condition with low oil control float restricting flow of oil from air-oil tank to hydraulic jacks.
- B. Lift jumping at last stage of rise and/or lift dropping suddenly at beginning of down cycle. This indicates the system is low of oil and air is entering the jacks. A low oil control float must be installed after system has been refilled and bleed.

Check Oil Level.

NOTE: Refer to page 4, Figs. 8 & 9 for manual bleeder and fill plug detail.

- A. Pressurize tank with air by locking air valve with handle in position opposite muffler and fully charge tank.
- B. Open oil valve and raise lift about 2'-0".
- C. Open manual air bleeders on jacks two full turns. Close when oil appears.
- D. Lock air valve with handle in **EXHAUST** position toward muffler. Exhaust all air from tank. Lower lift to floor.

WARNING - TO AVOID PERSONAL INJURY

Lock air valve handle in the **EXHAUST** position and be sure all pressure has been expelled from air-oil tank before attempting to remove tank fill plug or fill plug vent screw.

- E. Use a screwdriver to manually open fill plug vent screw three full turns. If you hear air escaping, "**STOP**", the system is still pressurized. Repeat step E.
- F. Remove fill plug vent screw.
- G. Use a $\frac{3}{4}$ " drive pull bar to manually remove fill plug assembly. **Do Not** use impact wrench.
- H. Add oil as required to gauge level. **Do not overfill.**
- I. Coat the fill plug threads with anti-seize compound to retard rusting. Reinstall plug in coupling. **Do Not** coat, dope or tape fill plug vent screw threads. Reinstall fill plug vent screw and seal. Check for fill plug leaks.
- J. Never use a substitute plug or modify this vent feature.

 Pentax

ROTARY LIFT

P.O. Box 1560 Madison, IN 47250
 WORLD LEADER IN LIFT SYSTEMS
 A **DOVER** INDUSTRIES COMPANY

MODEL DTO28H MKVI

PARTS BREAKDOWN

Serial Number 370111-and above

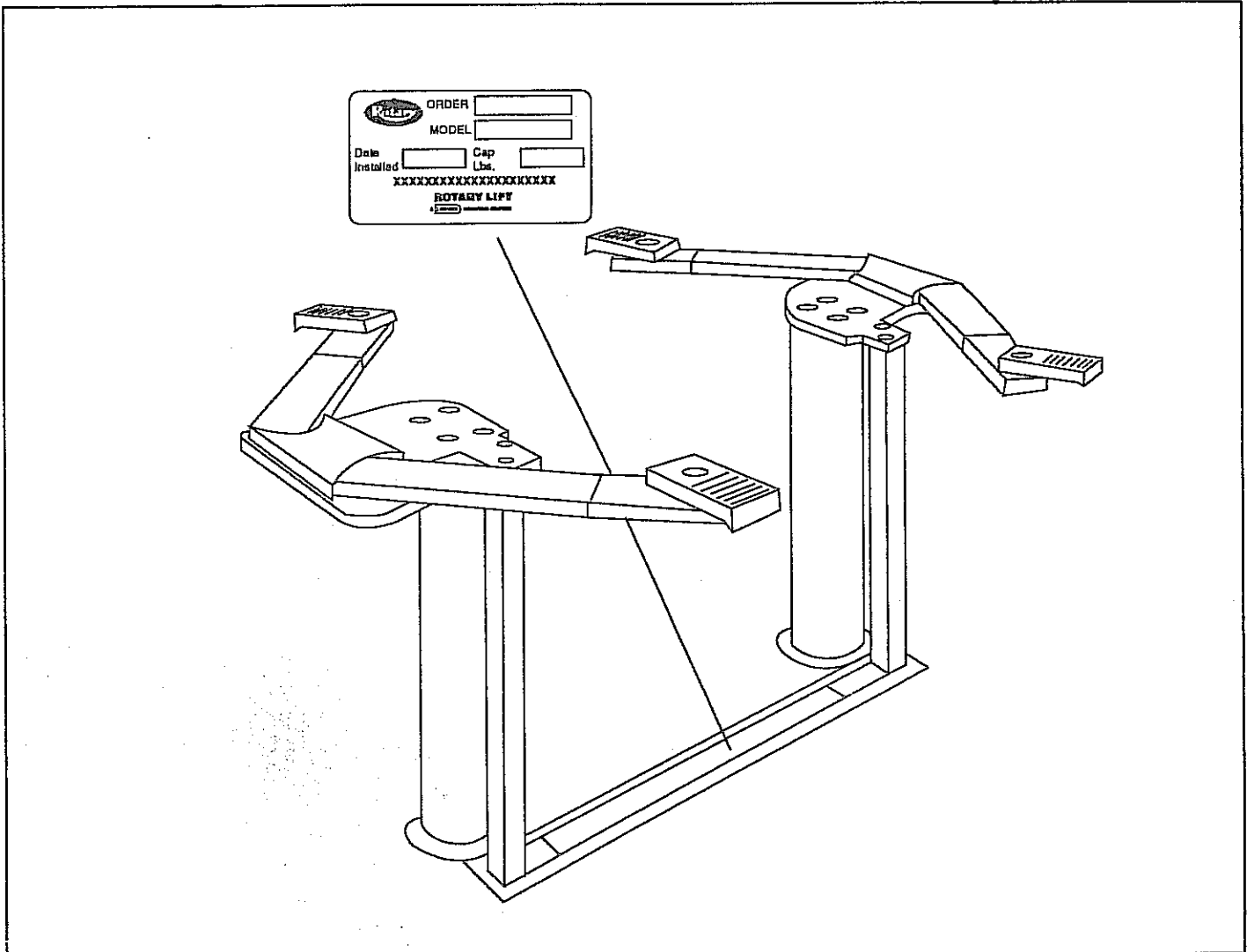

IMPORTANT: When ordering parts or requesting service, always give exact model and jack serial number. Model number is located on nameplate as shown above. Jack serial number is located on side of plunger at point of attachment to superstructure.

NOTES:

Jack Serial Number 370111, Factory Order Number L87295, on Sept. 3, 1992 Changed bolt hole pattern from rectangular to square, not interchangeable. For models shipped before Sept. 3, 1992 refer to index 5.1.13.1

OWNERS RECORD

Complete information at right and keep in a safe place.

Date Installed _____ / _____ / _____

Installed In Bay # _____

Serial # _____ JG199

_____ JG199

Factory Order # L _____

Model No# _____

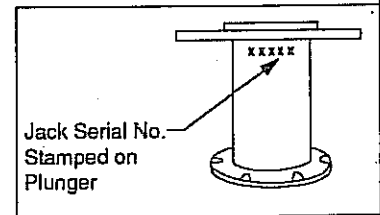

Jack Serial No. Stamped on Plunger

NOTE: For Replacement Parts - See Your Nearest Rotary Parts Distributor

INDEX 5.1.13.2
 A Rev. 11/96

**JG199 JACK
(6-HOLE BOLT PATTERN)**

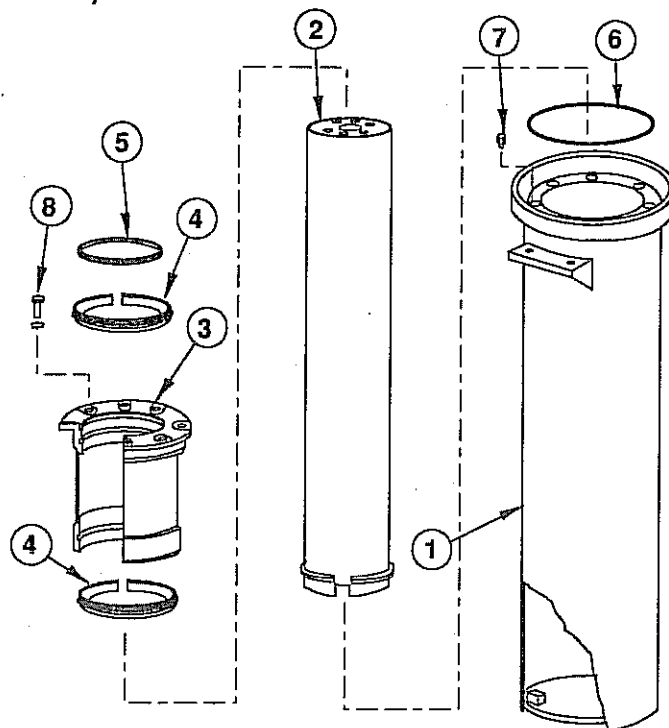

(TS) JG199JACK PARTS		
ITEM NO.	DESCRIPTION	PART NO.
1	Casing Assembly	JG766
2	Plunger Assembly (6 Hole)	JG446
3	Guide Assembly	JG512
4	Jack Bearing	JG766-6
5	Seal	JG227
6	"O" Ring	JG37
7	Bleeder Screw	JX207
8	1/2"-13NC HHCS GD 8 x 1 14" Lg. & Ext Tooth LW	8 Req'd
9	Packing Gland	N/A

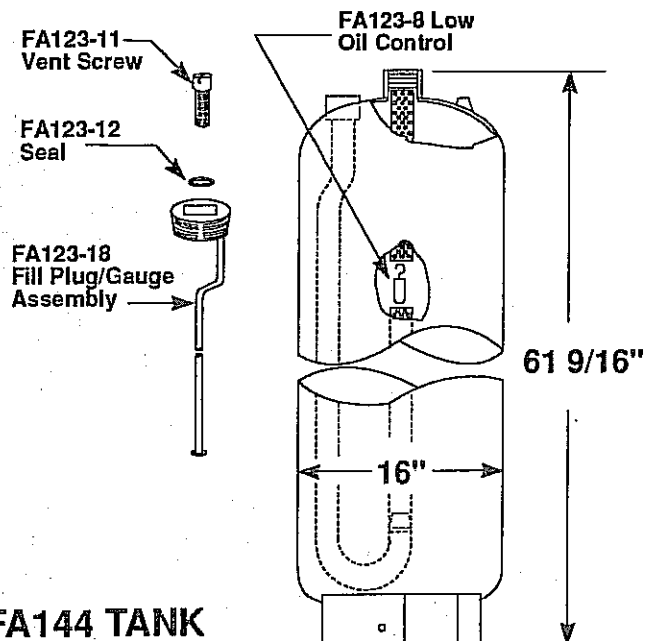

(T1A) ADAPTER PARTS		
ITEM NO.	DESCRIPTION	PART NO.
1	Adapter High Step	FJ671-1
2	Adapter Low Step	FJ671-2
3	Adapter Pin	FJ671-3
3A	Hog Ring Clips	FJ671-6
4	Adapter Base ("X" Dim 19")	FJ692-1
	Adapter Base ("X" Dim 24")	FJ693-1
5	Swivel Pin	FJ671-5

(T1) SUPERSTRUCTURE PARTS		
ITEM NO.	DESCRIPTION	PART NO.
1	Left Hand Yoke	FJ2233
2	Right Hand Yoke	FJ2234
3	Arm	FJ2199
4	Adapter (Rear)	FJ693
5	Adapter (Front)	FJ692
6	Wheel Spotting Dish	FF729
7	7/8"-9NC x 2 1/2" HHCS GR. 5	8 Req'd
8	1/2"-13NC x 2 1/2" HHCS w/nut and lock washer	4 Req'd

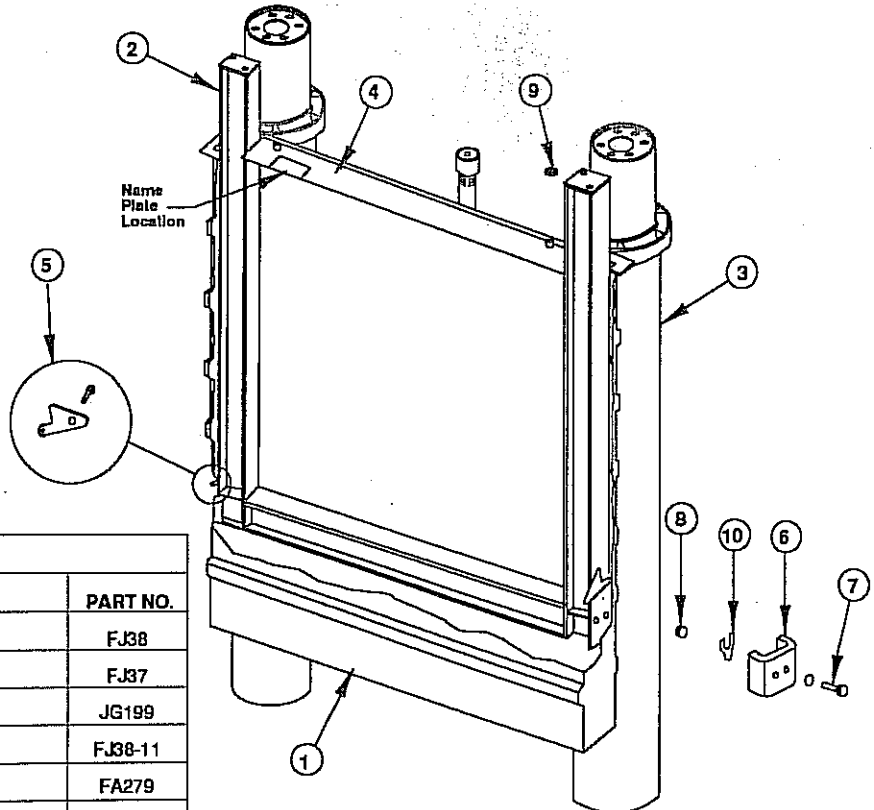
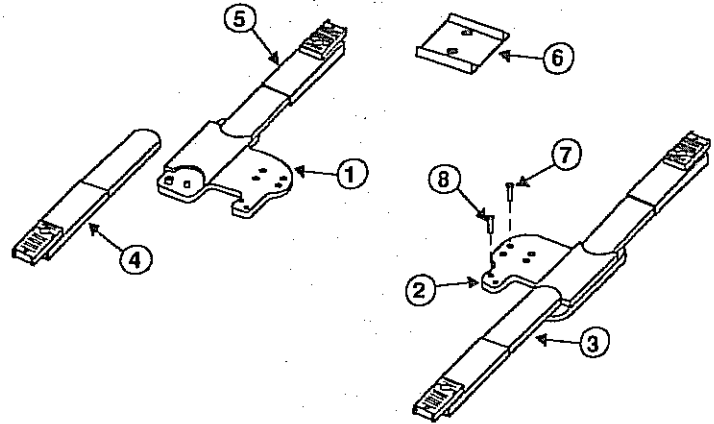
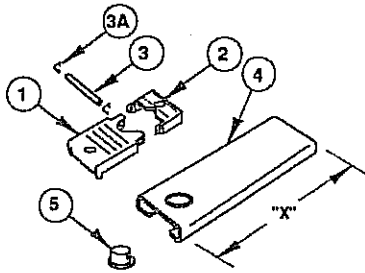

(T2) IN-GROUND PARTS		
ITEM NO.	DESCRIPTION	PART NO.
1	Equalizer Housing	FJ38
2	Equalizer Frame	FJ37
3	Jack Assembly	JG199
4	Center Cover	FJ38-11
5	Replacement Latch Kit (Includes 2 Latches)	FA279
6	Slider Block	FJ321-5
7	5/16"-18NC x 1" Lg. HHCS, & 5/16" Plain Washer	4 Req'd
8	5/16"-18NC Hex Nut	4 Req'd
9	1/4"-20NC Hex Nut	2 Req'd
10	Shim	-----

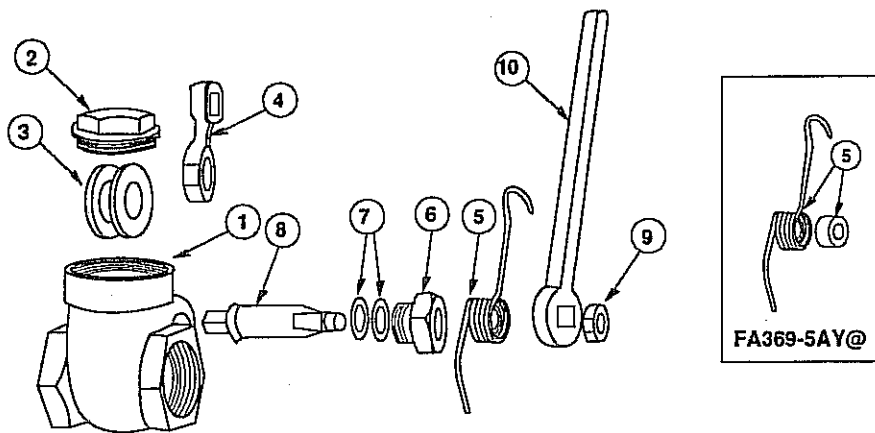

- * Valve body not available as a replacement part. If valve body needs replacing, order a new FA369 valve.
- ** Always give valve manufacturer when ordering parts. Valve manufacturer located on valve body or on lever. If valve is a MacDonald, order parts with the suffix of AY. (Example: FA369-5AY, FA369-10AY, FA369-2AY, Etc.)
- @ FA369-5AY spring also includes a nylon reducing bushing.

(T4) FA369 HAND OPERATED OIL VALVE PARTS		
ITEM/NO.	DESCRIPTION	PART NO.**
1	Body*	N/A
2	Cap	FA369-2
3	Disc	FA369-3
4	Lever	FA369-4
5	Spring	FA369-5
6	"O" Ring Retainer	FA369-6
7	"O" Ring	FA369-7
8	Stem	FA369-8
9	Handle Nut	FA369-9
10	Lever Handle	FA369-10

(T5) FA377 LOCKING AIR VALVE		
ITEM NO.	DESCRIPTION	PART NO.
1	Body@	N/A
2	Cap	FA376-2
3	Spring	FA376-3
4	Locking Lever	FA377-1
5	Pin	FA376-5
6	Snap Ring	FA376-6
7	Rocker Arm	FA376-7
8	Disc	FA376-8
9	Disc Cage	FA376-9
10	Stem	FA376-10
11	Stem Nut	FA376-11
12	"O" Ring	FA376-12
13	Screen	FA376-13
14	Muffler (Includes 1/2" Street Elbow)	FA515
15	Stem Assy. Pc's 8, 9, 10, 11 & 12	FA376-15

@ Valve Body Not Available As A Replacement Part. If Body Needs Replacing, Order A New FA377 Valve.

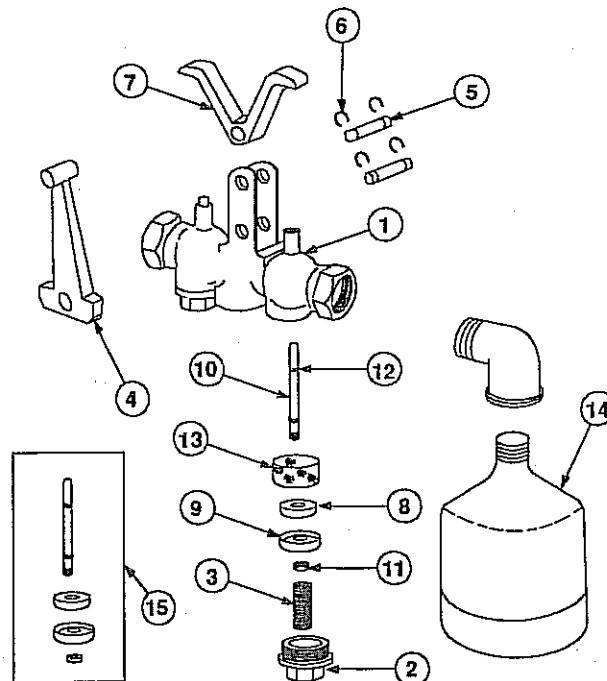

Rotary Lift[®]

INDEX 5.1.13.2

ROTARY LIFT
A Dover Industries Company
P.O. Box 1560
Madison, Indiana 47250-0560
Phone toll-free: 1-800-445-LIFT (5438)
(812) 273-1622
FAX : (812) 273-6502

For Export
ROTARY LIFT EXPORT
COMPANY
200 Executive Drive, Suite 320
West Orange, NJ 07052
(201) 325-3535
Telex # 13-8693
FAX: (201) 325-7974

For Canada:
DOVER CORPORATION CANADA -
ROTARY LIFT DIVISION
130 Bridgeland Avenue, Unit 210
Toronto, Ontario, Canada M6A 1Z4
(416) 256-4100
FAX : (416) 256-3924