

Project :

Model # :

Item # :

Qty :

Approval :

Condensing Unit

Model : TH050LR404A2



≡ FEATURES / BENEFITS ≡

- Blue anti-corrosion-fin increases the life span of the coil.
- Seamless inner groove copper tube increases the heat exchange rate by reducing the space between the fin and copper tube.
- Highest quality compressor in the world.

- Head pressure control stabilizes the freezing of liquid line, minimizes formation of flash gas to increase efficiency of the system, and prevents compressor damage by controlling high pressure.
- Experienced engineers have designed the system for maximum efficiency.
- Fan Blades : Specifically matched with motors and coil for maximum air movement and cooling.
- Control box is designed for easy installation.
- Low pressure control is adjustable.
- All the parts are compliant with industry standards and interchangeable with readily available parts.
- Wiring : Easily accessible. Compressor comes with a wiring harness that is manufactured with connections that will not come loose with vibration.
- Control box and service valves are located outside for easy service.
- Base : Heavy duty steel. Legs are 2-1/6" tall
- Cabinet : Prepainted with galvanized body. Protects against corrosion.
- All products carry UL, cUL, ISO 9001 approvals.

Condensing Unit

Model : TH050LR404A2

PERFORMANCE CHART

	40°F(SST)	30°F	25°F	20°F	0°F	-10°F	-20°F	-25°F
90°F(AMBIENT)	-	49470	45010	40420	24860	18110	14300	10500
95°F	-	46670	42460	38130	23450	17080	13490	9900
100°F	-	43860	39910	35840	22050	16050	12690	9310
110°F	-	39870	35920	32070	18230	12840	10150	7450

SPECIFICATION

	TH050LR404A2
Compressor	CS33K6E-PFV
Line Size	1/2" Liquid 1-1/8" Suction
Receiver 90%	18
Fan Data	1Fan (3760CFM)
Dimensions	38.5(D) x 30.28(W) x 27.28(H)
Net Weight	292 Lbs
Power Supply	208-230/1ph/60hz
Compressor Amp	30.7
MCA	40.6
MOPD	60

Design and specifications subject to change without notice

- **WARRANTY :** 1 Year Compressor Warranty (4 Year extended warranty available)
1 Year Fan Motor and Parts Warranty

(unit : inch)

PLAN VIEW

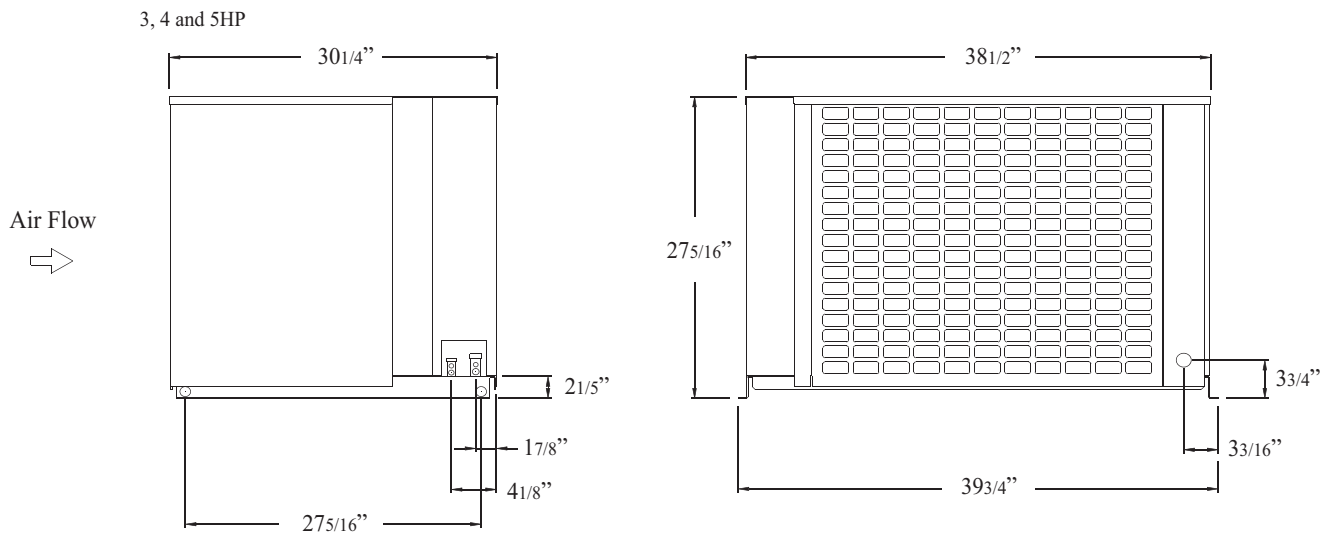

■ Toll Free : 888-900-1002

REFRIGERATOR MANUFACTURER
Turbo air

GERMAN KNIFE

RADIANCE

GREEN WORLD

AIR CONDITIONER MANUFACTURER
Turbo air