



## Product Catalog

**ZERMA**

The Home of Size Reduction

# Table of contents



## Product Catalog

<b>Solutions for Inline Recycling</b>		<b>Page</b>
Series of beside the press granulators	GSL 150 _____	04
	GSL 180 _____	06
	GSL 300 _____	08
Series of compact granulators	GSE 300 _____	10
	GSE 500 _____	12
	GSE 700 _____	14
Series of sound - proof compact granulators	GSC 300 _____	16
	GSC 500 _____	18
	GSC 700 _____	20
Series of compact granulators with tangential feed	GST _____	22
Series of pulverizers	PM _____	24
Series of large granulators	GSH 350-500 _____	26
	GSH 600-700 _____	28
	GSH 800 _____	30
	GSH 1100 _____	32
Series of granulators for pipes and profiles	GSP _____	34

<b>Single Shaft Shredder Machine Program</b>	<b>Page</b>
Series of compact single-shaft shredders	ZBS _____ 36
Series of universally applicable single shaft shredders	ZSS/ZPS _____ 38
	ZIS _____ 40
Series of single shaft shredders with horizontal infeed	ZHS _____ 42
	ZHS+ _____ 44
Series of high-performance single-shaft shredders	ZXS _____ 46
Series of single shaft shredders for size reduction of pipe and profile	ZRS _____ 48
Series of single shaft shredders for size reduction of tires	ZTS/ZTTS _____ 50
Hammer Mill	ZHM _____ 52
Shredder/Granulator Combination	ZCS _____ 54

We reserve the right to make technical changes and measurement adjustments. Ver. 1.0 - 04/2019/ EN  
 Images shown in this brochure may also contain optional equipment variants.

# GSL 150

## Beside the press granulator



- Direct drive via geared motor
- Special knife design makes adjustment unnecessary
- Easy access for maintenance and cleaning
- Slow rotor speed creates less noise and dust
- Easily customizable to suit different applications

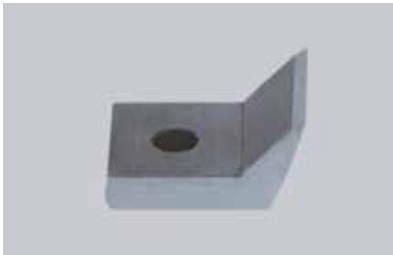

The curvature of the specially profiled rotor knives ensures a constant cutting radius after resharpening thus maintaining the original cutting gap. Awkward knife adjustments are no longer necessary.

### Applications

The beside-the press GSL 150/150 – GSL 150/350 slow runner series is designed for light applications in the field of injection molding.



Staggered rotor blades creates an individual blade cut, increasing the cutting torque. All of the machines in this series are suitable for grinding more solid materials and thicker walled sprues.

### General Description

Not only does the GSL 150 series include the standard advantages such as low noise and dust free operation, the granulator series offers a new designed rotor, stator knife, and Quick-Snap-System for easy access during maintenance and cleaning.



The ZERMA Quick Snap System allows the lower front plate section to be easily removed for granulator clean-ing. The lower front plate section is held in position by two sturdy lever clamps.

The granulator feeding can be performed by hand or via a robot into the large dimensioned hopper which is built in layered construction. Material is discharged through the easily accessible screen into the granulator discharge pan, which includes a discharge pipe from connection of a down-stream vacuum loader. Different from the standard Zerma slow speed granulators, the GSL 150 series uses drive belt technology for motor/granulator power. The drive belt technology reduces the space needed for location of the machine.

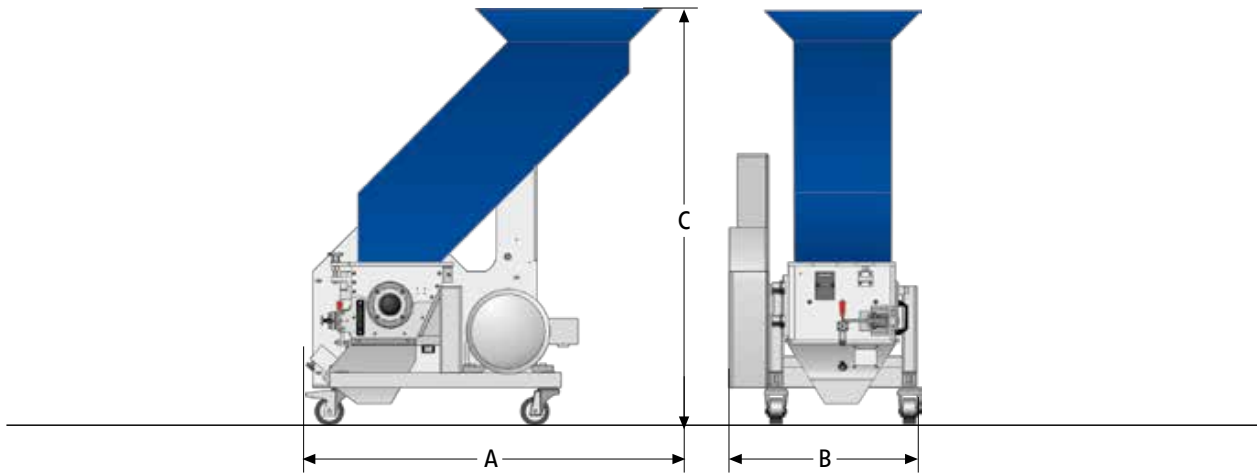

### Technical Specifications

Type	150/150	150/250	150/350
Rotor diameter (mm)	150	150	150
Rotor width (mm)	150	250	350
Rotor speed (rpm)	190	190	190
Drive capacity (kW)	1.5	2.2	3.0
Rotor knives (pcs)	15	27	26
Stator blades (rows)	2 (4-cutting edges)	2 (4-cutting edges)	2 (4-cutting edges)
Screen size (mm)	> 5	> 5	> 5
Weight approx. (kg)	110	120	140

### Dimensions

Type	150/150	150/250	150/350
A (mm)	980	980	980
B (mm)	397	509	593
C (mm)	1150	1150	1150

# GSL 180

## Beside the press granulator



- Direct driven staggered rotor
- Special knife design makes adjustment unnecessary
- Easy access for maintenance and cleaning
- Slow rotor speed creates less noise and dust
- Easily customizable to suit different applications

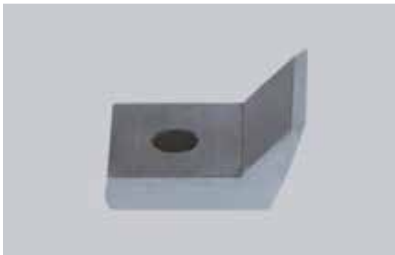

The curvature of the specially profiled rotor knives ensures a constant cutting radius after re-sharpening thus maintaining the original cutting gap. Awkward knife adjustments are no longer necessary.

### Applications

The GSL slow speed granulators of the 180 series are mainly used in injection and blow molding processes as beside the press machines to grind runners and sprues. The resulting granules are then immediately reintroduced into the production process. The machines can be used for rejected products in the inline recycling process as well. Different hopper and base frame designs make it possible to integrate the machine with most types of injection molding machines and robots.

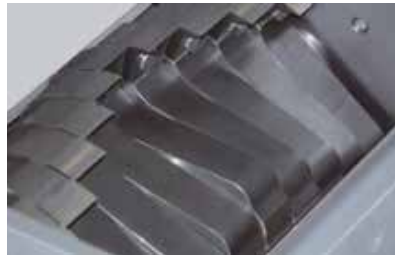

Staggered rotor blades create an in-dividual blade cut increasing the cutting torque. All of the machines in this series are suitable for grinding more solid materials and thicker walled sprues.

### General Description

The slow speed granulators in the GSL 180 range feature a staggered 180 mm diameter rotor with widths ranging from 180 to 430 mm. The rotor is directly driven by a geared motor. The low rotor speed reduces the noise level of the machine and creates less dust while grinding. The special design knives of the GSL series can be sharpened easily and do not need adjustment afterwards. The material is fed via a sound absorbing feed hopper that can be tailored to fit various applications and feeding ways. Depending on the requirements the machines can be fitted with a wide variety of hoppers, they are mounted on either low or high level base frames with matching suction bins or bag filling adapters. Quick snap fasteners and hand screws make access to the machine for cleaning and maintenance fast and easy.



The ZERMA Quick Snap System allows the lower front plate section to be easily removed for granulator cleaning. The lower front plate section is held in position by two sturdy lever clamps.

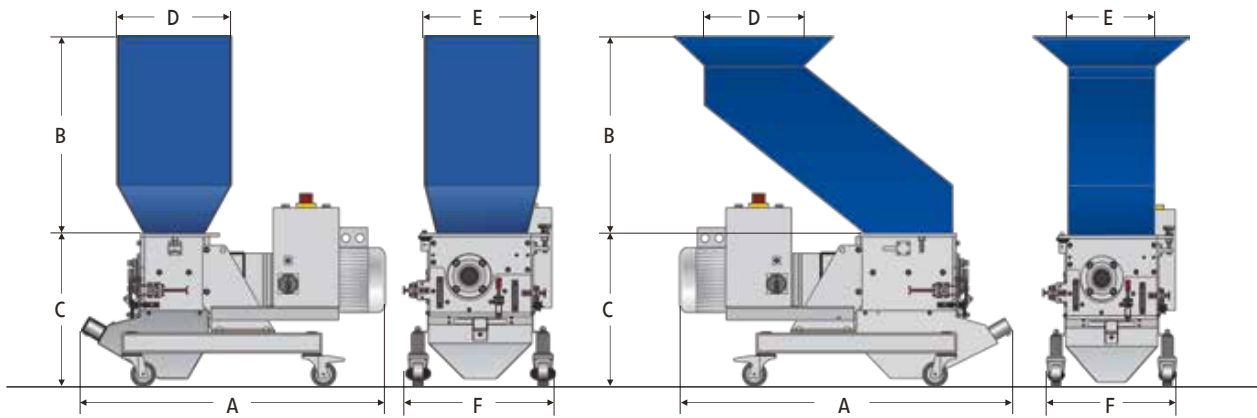

## Technical Specifications

Type	180/120	180/180	180/300	180/430
Rotor diameter (mm)	180	180	180	180
Rotor width (mm)	120	180	300	430
Rotor speed (rpm)	150	150	150	150
Drive capacity (kW)	2,2	3	4	4
Rotor knives (pcs)	12	18	30	45
Stator blades (rows)	2	2	2	2
Screen size (mm)	>5	>5	>5	>5
Weight approx. (kg)	130	140	180	250

## Dimensions with straight hopper

Type	180/120	180/180	180/300	180/430
A (mm)	835	890	1100	1240
B (mm)	610	610	610	910
C (mm)	460	460	460	550
D (mm)	345	345	345	430
E (mm)	345	345	345	290
F (mm)	455	455	455	615

## Dimensions with inclined hopper

Type	180/120	180/180	180/300	180/430
A (mm)	835	895	1100	1240
B (mm)	760	760	760	820
C (mm)	470	470	470	560
D (mm)	315	315	345	525
E (mm)	270	270	270	270
F (mm)	440	440	440	540



zerma.com

# GSL 300

## Beside the press granulator



- Direct driven staggered rotor
- Special knife design makes adjustment unnecessary
- Easy access for maintenance and cleaning
- Slow rotor speed creates less noise and dust
- Easily customizable to suit different applications

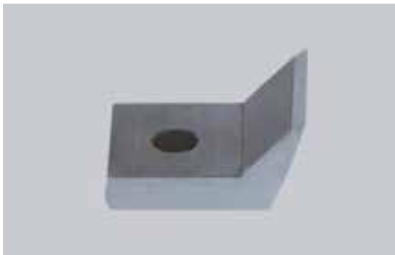

The curvature of the specially profiled rotor knives ensures a constant cutting radius after re-sharpening thus maintaining the original cutting gap. Awkward knife adjustments are no longer necessary.

### Applications

The GSL slow speed granulators of the 300 series are mainly used in injection and blow molding processes as beside the press machines to grind runners and sprues. But they can be used as low noise central granulators for small throughput requirements as well. The stronger design of the 300 series GSLs allow them to be used for stronger and thicker materials while offering the same advantages regarding low noise and dust as the smaller GSL machines. All GSL models can be equipped with a built in blower system in case a vacuum loading system is not available, or to transport the ground material to bags for storage.



Staggered rotor blades create an in-dividual blade cut increasing the cutting torque. All of the machines in this series are suitable for grinding more solid materials and thicker walled sprues.

### General Description

The slow speed granulators in the GSL 300 range feature a staggered 300 mm diameter rotor with widths ranging from 400 to 800 mm. The rotor is directly driven by a geared motor. The low rotor speed reduces the noise level of the machine and creates less dust while grinding. The special design knives of the GSL series can be sharpened easily and do not need adjustment afterwards. The material is fed via a sound absorbing feed hopper that can be tailored to fit various applications and feeding ways. Depending on the requirements the machines can be fitted with a wide variety of hoppers, they are mounted on either low or high level base frames with matching suction bins or bag filling adapters. Quick snap fasteners and hand screws make access to the machine for cleaning and maintenance fast and easy.



Due to the Quick snap fasteners used on the GSL series machines, the machines can be opened for cleaning and maintenance quickly without the need for special tools.



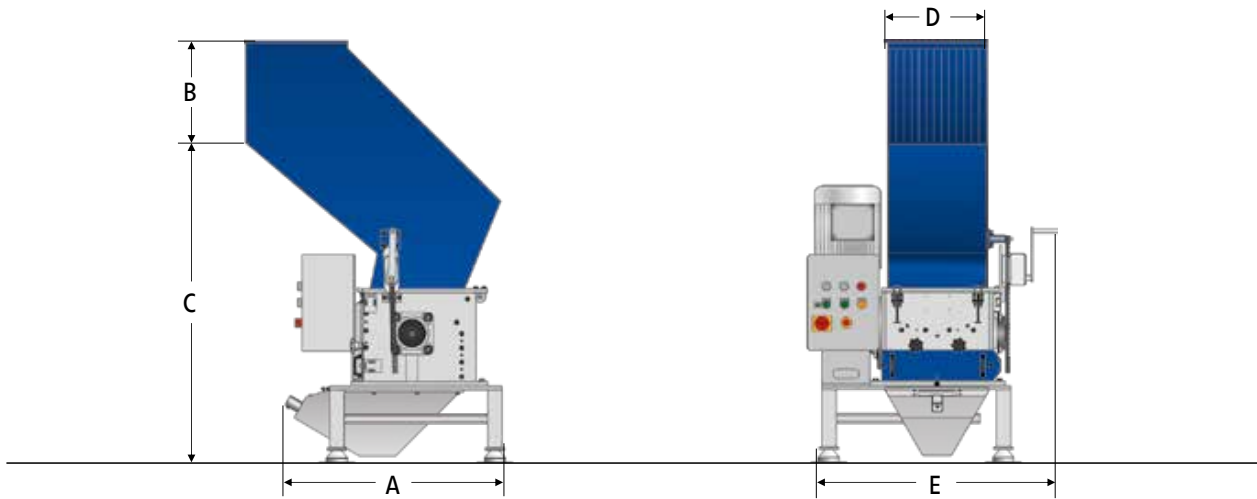

### Technical Specifications

Type	300/400	300/600	300/800
Rotor diameter (mm)	300	300	300
Rotor width (mm)	400	600	800
Rotor speed (rpm)	150	150	150
Drive capacity (kW)	7.5	11	18.5
Rotor knives (pcs)	33	48	66
Stator blades (rows)	2	2	2
Screen size (mm)	> 6	> 6	> 6
Weight approx. (kg)	550	950	1100

### Dimensions

Type	300/400	300/600	300/800
A (mm)	950	1125	820
B (mm)	400	400	400
C (mm)	1335	1335	1340
D (mm)	405	600	830
E (mm)	1035	1230	1635

# GSE 300

## Economical granulators



- Knives are adjusted outside of the machine
- Mobile Compact design
- Different rotor types available
- Easy accessibility
- Aggressive tangential infeed



Rotor and stator knives are pre-set outside the machine prior to installation in a supplied fixture. This makes awkward adjustment inside the machine unnecessary.

### Applications

The GSE series of machines are designed as economical granulators for use in in house recycling. The cutting geometry of the GSE 300 series makes it ideal for the grinding of small thin walled hollow parts. The complete GSE granulator line achieves a high quality regrind independent of the material type or form such as injection molding parts, blow molded parts, profiles, sheets, film, etc.



The GSE granulators are available with different rotor options to fit different applications, all rotors feature the V-cut technology creating a high quality regrind.

### General Description

For the GSE 300 series different rotor designs are available in widths ranging from 300 mm to 1400 mm with a diameter of 300 mm. The completely welded cutting chamber in conjunction with the "V" Type rotor design ensures depend-ability in operation and universal application use. The housing design offers easy and quick access to the cutting chamber during rotor and stator knife changes, servicing or screen changes.



The user friendly design of the GSE series granulators allows quick and easy access to the cutting chamber for maintenance and cleaning.

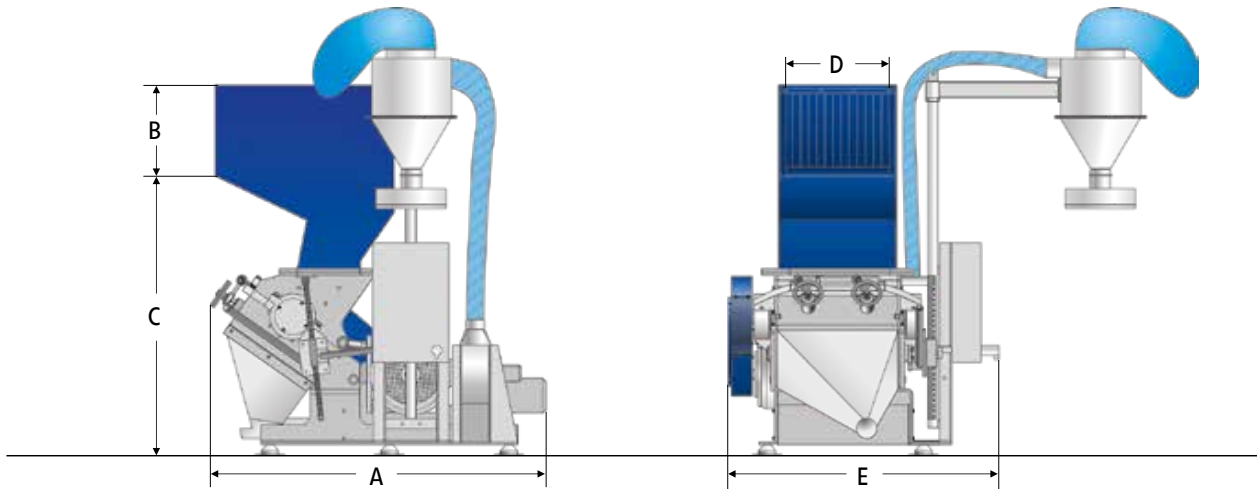

### Technical Specifications

Type	300/300	300/600	300/1000
Rotor diameter (mm)	300	300	300
Rotor width (mm)	300	600	1000
Drive capacity (kW)	7.5	18.5	18.5
Rotor knives (rows)	3	3	3
Stator blades (rows)	2	2	2
Screen size (mm)	> 6	> 6	> 6
Effective working area (mm)	400 x 290	400 x 590	400 x 990
Weight approx. (kg)	900	1000	1350

### Dimensions

Type	300/300	300/600	300/1000
A (mm)	1760	1810	1370
B (mm)	460	460	460
C (mm)	1420	1420	1420
D (mm)	300	590	990
E (mm)	1085	1350	1540

# GSE 500

## Economical granulators



- Knives are adjusted outside of the machine
- Mobile Compact design
- Different rotor types available
- Easy accessibility
- Aggressive tangential infeed



Rotor and stator knives are pre-set outside the machine prior to installation in a supplied fixture. This makes awkward adjustment inside the machine unnecessary.

### Applications

The GSE series of machines are designed as economical granulators for use in medium volume for in-house recycling applications. The cutting geometry of the GSE 500 series allows even bigger hollow parts to be ground. The whole GSE granulator line achieves a high quality regrind independent of the material Type or form such as injection molded parts, blow molded parts, profiles, sheets, film, etc.



The GSC granulators are available with different rotor options to fit different applications, all rotors feature the V-cut technology creating a high quality regrind.

### General Description

For the GSE 500 series different rotor designs are available in widths ranging from 500 mm to 1400 mm with a diameter of 500 mm. The completely welded cutting chamber in conjunction with the "V" Type rotor design ensures dependability in operation and universal application use. The housing design offers easy and quick access to the cutting chamber during rotor and stator knife changes, servicing or screen changes.



The user friendly design of the GSE series granulators allows quick and easy access to the cutting chamber for maintenance and cleaning.

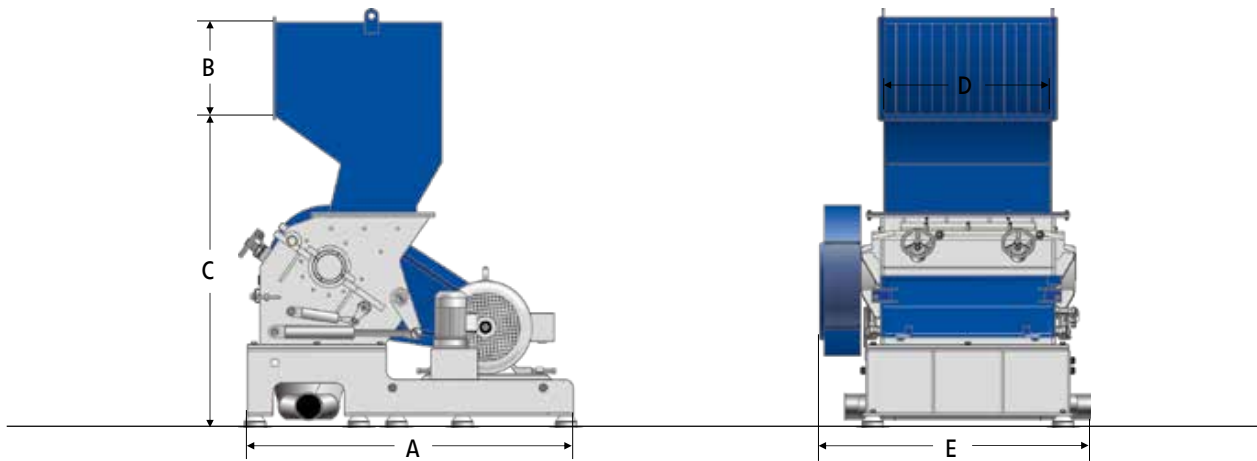

### Technical Specifications

Type	500/500	500/700	500/1000	500/1400
Rotor diameter (mm)	500	500	500	500
Rotor width (mm)	500	700	1000	1400
Drive capacity (kW)	30	37	45	45
Rotor knives (rows)	3 or 5	3 or 5	3 or 5	3 or 5
Stator blades (rows)	2 or 3	2 or 3	2 or 3	2 or 3
Screen size (mm)	> 6	> 6	> 6	> 6
Effective working area (mm)	500 x 500	500 x 700	500 x 990	500 x 1400
Weight approx. (kg)	1500	1750	3100	3900

### Dimensions

Type	500/500	500/700	500/1000	500/1400
A (mm)	1675	1675	1900	1900
B (mm)	580	580	580	580
C (mm)	1840	1840	1840	1840
D (mm)	515	715	985	1430
E (mm)	1130	1330	1645	2120

# GSE 700

## Economical granulators



- Knives are adjusted outside of the machine
- Mobile Compact design
- Different rotor types available
- Easy accessibility
- Aggressive tangential infeed



Rotor and stator knives are pre-set outside the machine prior to installation in a supplied fixture. This makes awkward adjustment inside the machine unnecessary.

### Applications

The GSE series of machines are designed as economical granulators for use as central granulator for in-house recycling. The cutting geometry of the GSE 700 series allows even voluminous materials to be ground. The complete GSE series line achieves a high quality regrind independent of the material type or form such as injection molded parts, blow molded parts, profiles, sheets, film, etc.



The GSE granulators are available with different rotor options to fit different applications, all rotors feature the V-cut technology creating a high quality regrind.

### General Description

For the GSE 700 series different rotor designs are available in widths ranging from 700 mm to 1400 mm with a diameter of 700 mm. The completely welded cutting chamber in conjunction with the "V" type rotor design ensures dependability in operation and universal application use. The housing design offers easy and quick access to the cutting chamber during rotor and stator knife changes, servicing, or screen changes.



The base of the GSE 700 series makes the machine very sturdy, while maintaining the easy accessibility for maintenance and cleaning.

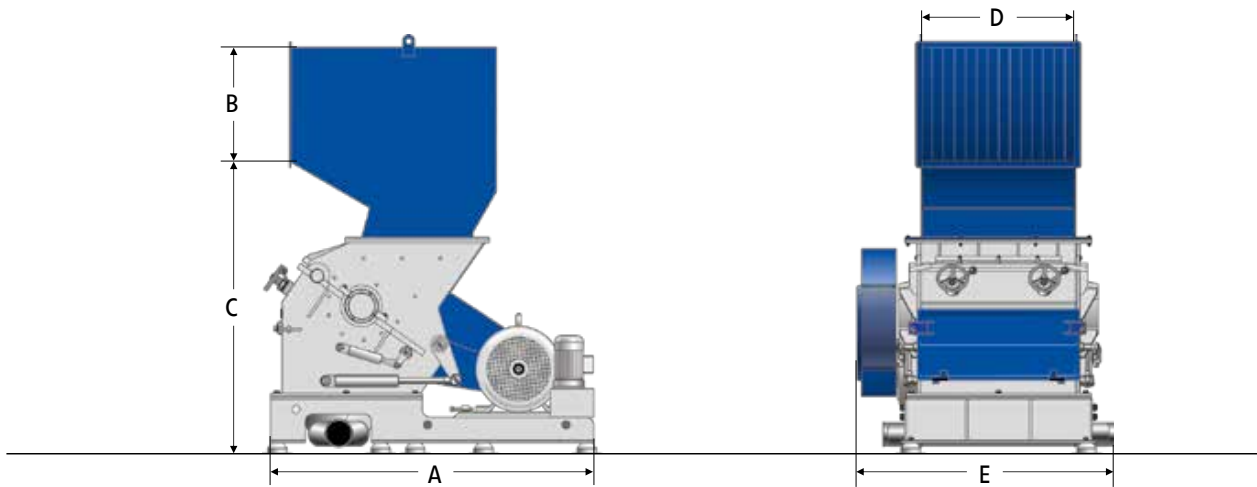

### Technical Specifications

Type	700/700	700/1000	700/1400
Rotor diameter (mm)	700	700	700
Rotor width (mm)	700	1000	1400
Drive capacity (kW)	45	55	55
Rotor knives (rows)	5 or 7	5 or 7	5 or 7
Stator blades (rows)	2 or 3	2 or 3	2 or 3
Screen size (mm)	> 6	> 6	> 6
Effective working area (mm)	720 x 700	720 x 990	720 x 1400
Weight approx. (kg)	2840	3530	4500

### Dimensions

Type	700/700	700/1000	700/1400
A (mm)	2050	2050	2050
B (mm)	780	780	780
C (mm)	2040	2040	2040
D (mm)	715	985	1430
E (mm)	1400	1670	2120

# GSC 300

## Compact sound-proofed granulators



- Knives are adjusted outside of the machine
- Compact design
- Different rotor types available
- Soundproofed housing
- Aggressive tangential infeed



Rotor and stator knives are pre-set outside the machine prior to installation in a supplied fixture. This makes awkward adjustment inside the machine unnecessary.

### Applications

The cutting geometry of the GSC series allows even voluminous materials to be ground. The complete GSC series line achieves a high quality regrind independent of the material type or form such as injection molded parts, blow molded parts, profiles, sheets, film, etc. The 300 series GSC machines are mainly used in inline operations for processing of rejected products, or runners and sprues. The small footprint and easy movability make the machines very easy to place in existing operations.



The GSC granulators are available with different rotor options to fit different applications, all rotors feature the V-cut technology creating a high quality regrind.

### General Description

The GSC compact/sound proof granulators are designed with a complete sound proof enclosure resulting in an extremely quiet operation. Different rotor designs are available in widths ranging from 300 mm to 1400 mm with a diameter of 300 mm. The completely welded cutting chamber in conjunction with the "V" type rotor design ensures dependability in operation and universal application use. While it delivers excellent sound proofing capabilities, it still offers easy and quick access to the cutting chamber during rotor and stator knife changes, servicing, or screen changes. The sound dampening material used in these machines is based on the latest technological research.



To minimize the needed floor space and make the machine easy to move, machine controls and electrical cabinet are integrated into the machines soundproof housing.



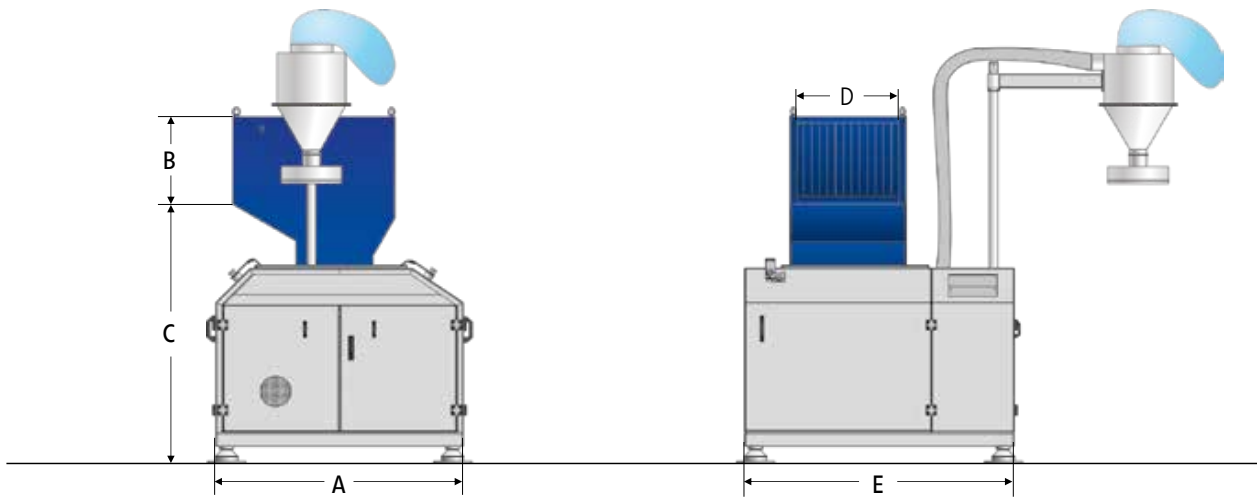

### Technical Specifications

Type	300/300	300/600	300/1000
Rotor diameter (mm)	300	300	300
Rotor width (mm)	300	600	1000
Drive capacity (kW)	7.5	18.5	18.5
Rotor knives (rows)	3	3	3
Stator blades (rows)	2	2	2
Screen size (mm)	> 6	> 6	> 6
Effective working area (mm)	400 x 290	400 x 590	400 x 990
Weight approx. (kg)	1200	1400	1850

### Dimensions

Type	300/300	300/600	300/1000
A (mm)	1550	1550	1550
B (mm)	420	420	420
C (mm)	1570	1570	1570
D (mm)	300	590	990
E (mm)	1300	1600	1900

# GSC 500

## Compact sound-proofed granulators



- Knives are adjusted outside of the machine
- Compact design
- Different rotor types available
- Soundproofed housing
- Aggressive tangential infeed



Rotor and stator knives are pre-set outside the machine prior to installation in a supplied fixture. This makes awkward adjustment inside the machine unnecessary.

### Applications

The cutting geometry of the GSC series allows even voluminous materials to be ground. The complete GSC series line achieves a high quality regrind independent of the material Type or form such as injection molded parts, blow molded parts, profiles, sheets, film, etc. The 500 series GSC machines are mainly used in inline operations or small central granulators for processing of medium sized hollow, thin walled products or runners and sprues. The integrated sound proofing makes it possible to easily place the machine in existing operations. With different rotor designs and a wide variety of options the machines can be tailored for many different applications.



To ensure a safe operation and quick and easy access for cleaning and maintenance the GSC 500 machine's cutting chamber is opened hydraulically.

### General Description

The GSC compact/sound proof granulators are designed with a complete sound proof enclosure resulting in an extremely quiet operation. Different rotor designs are available in widths ranging from 500 mm to 1400 mm with a diameter of 500 mm. The completely welded cutting chamber in conjunction with the "V" type rotor design ensures dependability in operation and universal application use. While it delivers excellent sound proofing capabilities, it still offers easy and quick access to the cutting chamber during rotor and stator knife changes, servicing, or screen changes. The sound dampening material used in these machines is based on the latest technological research.



To minimize the needed floor space and make the machine easy to move, the control cabinet is integrated into the machine's soundproof housing.

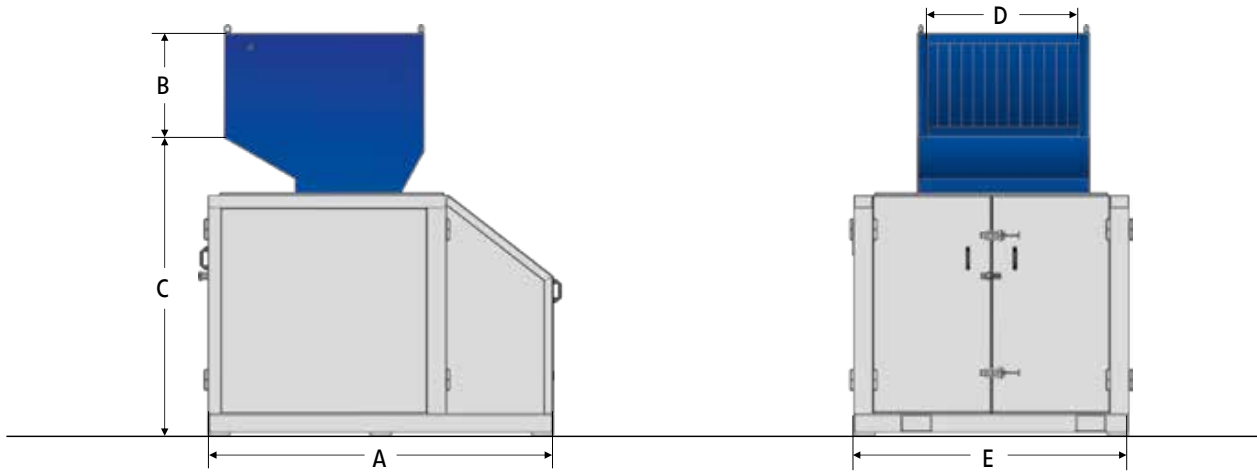

### Technical Specifications

Type	500/500	500/700	500/1000	500/1400
Rotor diameter (mm)	500	500	500	500
Rotor width (mm)	500	700	1000	1400
Drive capacity (kW)	30	37	45	45
Rotor knives (rows)	3 or 5	3 or 5	3 or 5	3 or 5
Stator blades (rows)	2 or 3	2 or 3	2 or 3	2 or 3
Screen size (mm)	> 6	> 6	> 6	> 6
Effective working area (mm)	560 x 500	560 x 700	560 x 990	560 x 1400
Weight approx. (kg)	2200	2500	3000	5500

### Dimensions

Type	500/500	500/700	500/1000	500/1400
A (mm)	1930	1930	2160	2160
B (mm)	580	580	580	580
C (mm)	1870	1870	1930	1930
D (mm)	515	715	985	1430
E (mm)	1550	1750	2100	2600

# GSC 700

## Compact sound-proofed granulators



- Knives are adjusted outside of the machine
- Compact design
- Different rotor types available
- Soundproofed housing
- Aggressive tangential infeed



Rotor and stator knives are pre-set outside the machine prior to installation in a supplied fixture. This makes awkward adjustment inside the machine unnecessary.

### Applications

The cutting geometry of the GSC series allows even voluminous materials to be ground. The complete GSC series line achieves a high quality regrind independent of the material type or form such as injection molded parts, blow molded parts, profiles, sheets, film, etc. The 700 series GSC machines are mainly used as central granulators for processing of large injected or blow molded products as well as film. The integrated sound proofing makes it possible to easily place the machine in existing operations. With different rotor designs and a wide variety of options the machines can be tailored for many different applications.



In order to keep the GSC series as compact as possible, motor and hydraulic opening system are integrated into the sound dampening enclosure of the machine.



The user friendly design of the GSC series granulators allows quick and easy access to the cutting chamber for maintenance and cleaning.

### General Description

The GSC compact/sound proof granulators are designed with a complete sound proof enclosure resulting in an extremely quiet operation. Different rotor designs are available in widths ranging from 700 mm to 1400 mm with a diameter of 700 mm. The completely welded cutting chamber in conjunction with the "V" Type rotor design ensures dependability in operation and universal application use. While it delivers excellent sound proofing capabilities, it still offers easy and quick access to the cutting chamber during rotor and stator knife changes, servicing or screen changes. The sound dampening material used in these machines is based on the latest technological research.

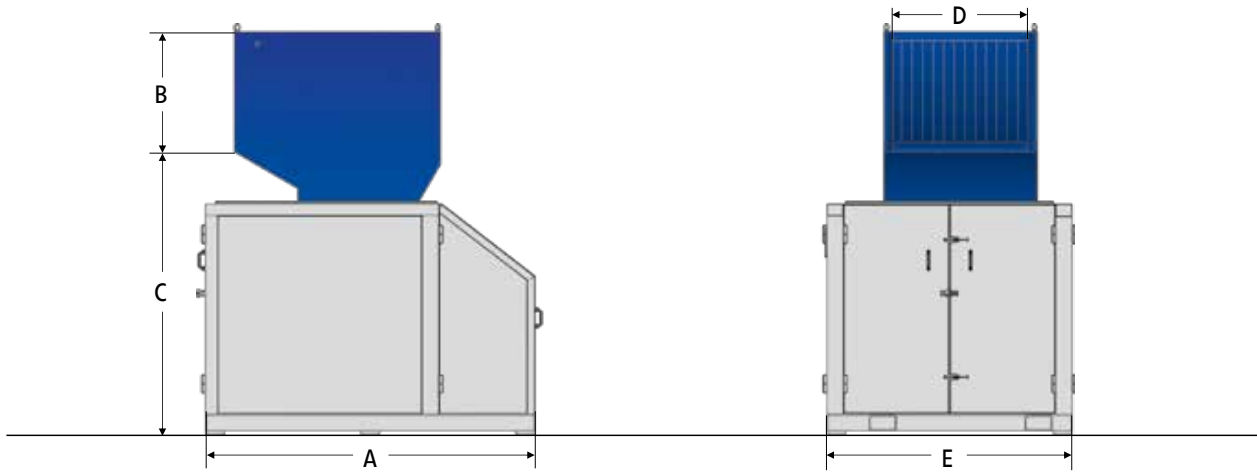

### Technical Specifications

Type	700/700	700/1000	700/1400
Rotor diameter (mm)	700	700	700
Rotor width (mm)	700	1000	1400
Drive capacity (kW)	45	55	55
Rotor knives (rows)	5 or 7	5 or 7	5 or 7
Stator blades (rows)	2 or 3	2 or 3	2 or 3
Screen size (mm)	> 6	> 6	> 6
Effective working area (mm)	720 x 700	720 x 990	720 x 1400
Weight approx. (kg)	4200	5100	6200

### Dimensions

Type	700/700	700/1000	700/1400
A (mm)	2260	2260	2260
B (mm)	780	780	780
C (mm)	2240	2240	2240
D (mm)	715	915	1430
E (mm)	1830	2100	2600

# GST

## Compact granulators



- Compact design
- Soundproofed chamber and hopper
- Aggressive infeed and curved backwall
- Large screen area
- Knives are adjusted outside of the machine



The GST granulators are designed for the inline recycling of voluminous parts such as bottles and canisters in blow-molding applications.

### Applications

The compact inline granulators of the GST series are primarily designed for use in blow molding applications to recycle voluminous parts such as bottles, canisters, and crates, as well as blow molding flush and injection sprues. The low feeding height makes them suitable for both hand and conveyor feeding of these parts. The low noise level and small footprint makes them the perfect fit for inline recycling operations.



The cutting chamber sits in a soundproofed enclosure to ensure quiet in-line operation. The rotor and screen area are easily accessible for cleaning and maintenance.

### General Description

All machines in the GST series feature a compact soundproofed enclosure and sound dampening hoppers. The granulators are available in two rotor diameters, 250 and 400 mm with widths ranging from 300 to 1000 mm. While the smaller machines feature an open F rotor, the bigger machines rely on a heavier S rotor. The curved back-wall of the cutting chamber ensures aggressive ingestion while also avoiding blockages. The rigid design makes them dependable units and includes advanced standard features such as replaceable wear plates. As on all ZERMA granulators the rotor and stator knives are adjusted outside of the machine to reduce downtime for maintenance.



The tangential cutting chamber paired with the aggressive open rotor design ensures reliable ingestion of voluminous parts. The curved cutting chamber back-wall reduces the risk of parts getting stuck.

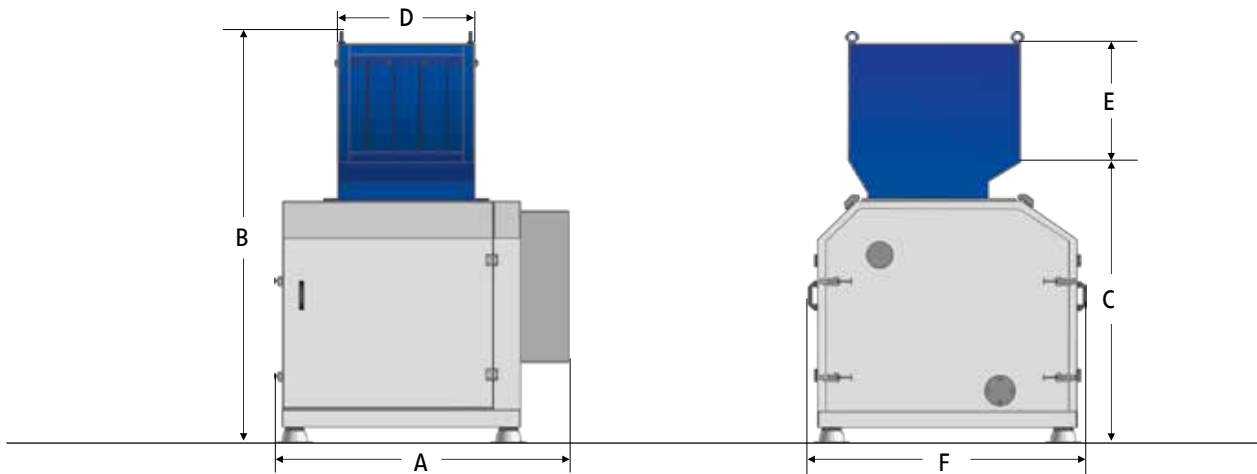

### Technical Specifications

Type	250/300	250/450	250/600	400/600	400/1000
Rotor diameter (mm)	250	250	250	400	400
Rotor width (mm)	300	450	600	600	1000
Drive capacity (kW)	7.5	11	18.5	22	30
Rotor knives (pcs)	3 x 1	3 x 1	3 x 2	3 x 2	3 x 2
Stator blades (rows)	2	2	2	2	2
Screen size (mm)	> 6	> 6	> 6	> 6	> 6
Effective working area (mm)	250 x 300	250 x 450	250 x 600	400 x 600	400 x 1000
Weight approx. (kg)	1200	1400	1850	3300	3300

### Dimensions

Type	250/300	250/450	250/600	400/600	400/1000
A (mm)	1350	1600	1750	1550	1950
B (mm)	1880	1880	1880	2180	2180
C (mm)	1380	1380	1380	1540	1540
D (mm)	300	450	600	590	990
E (mm)	370	370	370	490	490
F (mm)	1220	1220	1220	1460	1460

# PM

## High speed precision pulverizer



- Simple adjustment of cutting gap
- Choice of discs or segments
- Low drive power - High throughput
- Innovative efficient design
- Wide range of accessories
- Easy temperature control



The material temperature is monitored in the process, an automated cooling system will ensure the temperature is kept at a defined level.

### Applications

One of the main fields of use for the ZERMA PM Pulverizers is the pulverization of PVC regrind in pipe and profile recycling. Working in line with a shredder and granulator to have a balanced and efficient system to handle in house production waste. Another application is the grinding of PE for Rotomolding applications, here the PM Pulverizer is used in the production process to create the powder needed in the process. In this process a screening machine is necessary to ensure the right output size, distribution and flow properties of the ground material.



The material is fed into the Pulverizer by a vibrating dosing channel, the feeding rate is automatically adjusted based on the motors amperage and material temperature.

### General Description

The disc pulverizers of the PM series are available with disc diameter from 300 to 800 mm. These pulverizers are high speed, precision grinders for the processing of medium hard, impact resistant, and friable materials. The material to be pulverized is introduced through the center of a vertically fixed grinding disc which is mounted concentrically with an identical high speed rotating disc. Centrifugal force carries the material through the grinding area and the resulting powder is collected with a blower and cyclone system. Depending on the application the machines can be equipped with one piece grinding discs or grinding segments.



The ZERMA PM Pulverizers can be equipped with either one piece or segmented grinding discs, both are made from high quality tool steel and can be treated to withstand wear longer.



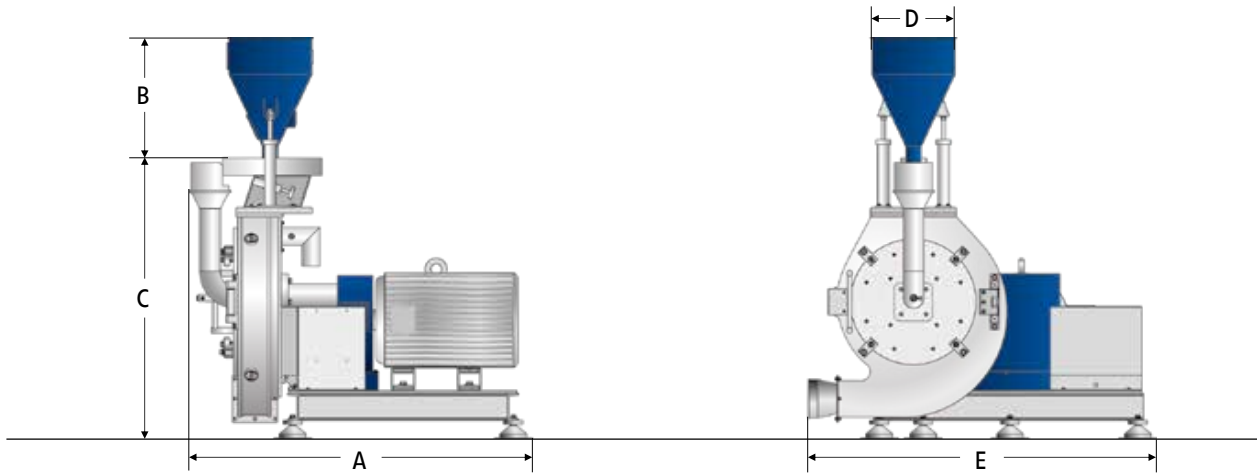

### Technical Specifications

Type	300	500	800
Discs diameter (mm)	300	500	800
Drive capacity (kW)	22	55	90
Weight approx. (kg)	900	1800	2500
Throughput approx (kg/h)	50 - 250	100 - 500	200 - 800

### Dimensions

Type	300	500	800
A (mm)	1365	1800	2085
B (mm)	640	640	640
C (mm)	1190	1470	1800
D (mm)	435	435	435
E (mm)	1515	1840	1680

# GSH 350-500

## Heavy duty granulators



- Knives are adjusted outside of the machine
- Specially developed deflector wedge
- Wide choice of rotors
- Well thought out housing design
- Strong Welded Steel construction
- Oversized outboard bearings

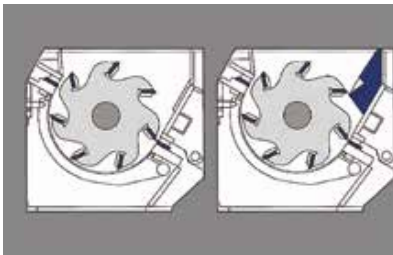

The easily removable deflector wedge acts as a third stator blade and can be used to adjust the aggressiveness of the rotor at the first cutting point.



The GSH granulators are available with different rotor options to fit different applications, all rotors feature the V-cut technology creating a high quality regrind.



The heavy duty bearings are separated from the cutting chamber to avoid lubricants entering the cutting chamber and bearing failure due to material contamination in the bearings.

### Applications

The wide range of rotors and hopper styles allow the GSH machines to be tailored to almost every application in the plastic recycling field. The GSH 350 and 500 granulators are mainly used as central granulators for in house recycling applications to process thick walled parts in one step or as a second step granulator after a shredder to reach higher throughput rates. For abrasive, contaminated or highly filled materials the machines can be equipped with special wear protections, such as hard facing of the rotor and housing and key parts manufactured from highly wear resistant steels.

### General Description

The heavy duty granulators of the GSH 350 and 500 series offer a wide array of different rotor designs with widths ranging from 500 mm to 1000 mm with a diameter of 350 and 500 mm respectively. The completely welded heavy steel construction is designed to withstand the most demanding and universal applications. Rotor bearings, knife mounts, and rotor shaft are oversized. The standard V-cut creates a high quality regrind with a very low percentage of fines in the output material. The removable third stator blade is acting as a deflector wedge and allows the machine to be quickly adjusted to different application scenarios. Other standard features include easily replaceable wear plates in the cutting chamber as well as outboard bearings reducing the risk of contamination.

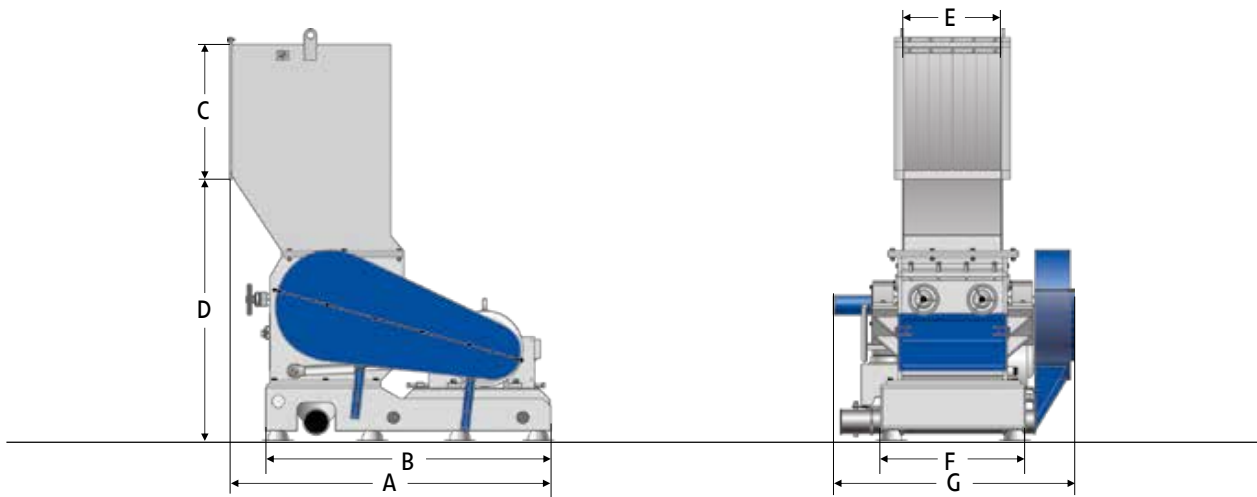

### Technical Specifications

Type	350/500	500/600	500/1000
Rotor diameter (mm)	350	500	500
Rotor width (mm)	500	600	1000
Drive capacity (kW)	22	55	75
Rotor knives (rows)	3 or 5	3 or 5	3 or 5
Stator blades (rows)	2 or 3	2 or 3	2 or 3
Screen size (mm)	> 6	> 6	> 6
Effective working area (mm)	460 x 516	636 x 590	985 x 590
Weight approx. (kg)	1800	3100	4200

### Dimensions

Type	350/500	500/600	500/1000
A (mm)	1820	2130	2320
B (mm)	1620	2020	2220
C (mm)	740	800	900
D (mm)	1610	1765	1870
E (mm)	515	635	985
F (mm)	775	1090	1540
G (mm)	1290	1570	1915

# GSH 600-700

## Heavy duty granulators



- Knives are adjusted outside of the machine
- Specially developed deflector wedge
- Wide choice of rotors
- Well thought out housing design
- Strong Welded Steel construction
- Oversized outboard bearings

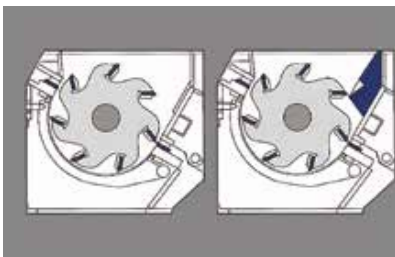

The easily removable deflector wedge acts as a third stator blade and can be used to adjust the aggressiveness of the rotor at the first cutting point.



The GSH granulators are available with different rotor options to fit different applications, all rotors feature the V-cut technology creating a high quality regrind.



The heavy duty bearings are separated from the cutting chamber to avoid lubricants entering the cutting chamber and bearing failure due to material contamination in the bearings.

### Applications

The wide range of rotors and hopper styles allow the GSH machines to be tailored to almost every application in the plastic recycling field. The GSH 600 and 700 granulators are mainly used as large central granulators for in house recycling applications to process large thick walled parts in one step or as a second step granulator after a shredder to reach higher throughput rates. For abrasive, con-taminated or highly filled materials the machines can be equipped with special wear protections, such as hard facing of the rotor and housing and key parts manufactured from highly wear resistant steels.

### General Description

The heavy duty granulators of the GSH 600 and 700 series offer a wide array of different rotor designs with widths ranging from 800 mm to 1000 mm with a diameter of 600 and 700 mm. The completely welded heavy steel construction is designed to withstand the most demanding and universal applications. Rotor bearings, knife mounts and rotor shaft are oversized. The standard V-cut creates a high quality regrind with a very low percentage of fines in the output material. The removable third stator blade is acting as a deflector wedge and allows the machine to be quickly adjusted to different application scenarios. Other standard features include easily replaceable wear plates in the cutting chamber as well as outboard bearings reducing the risk of contamination.

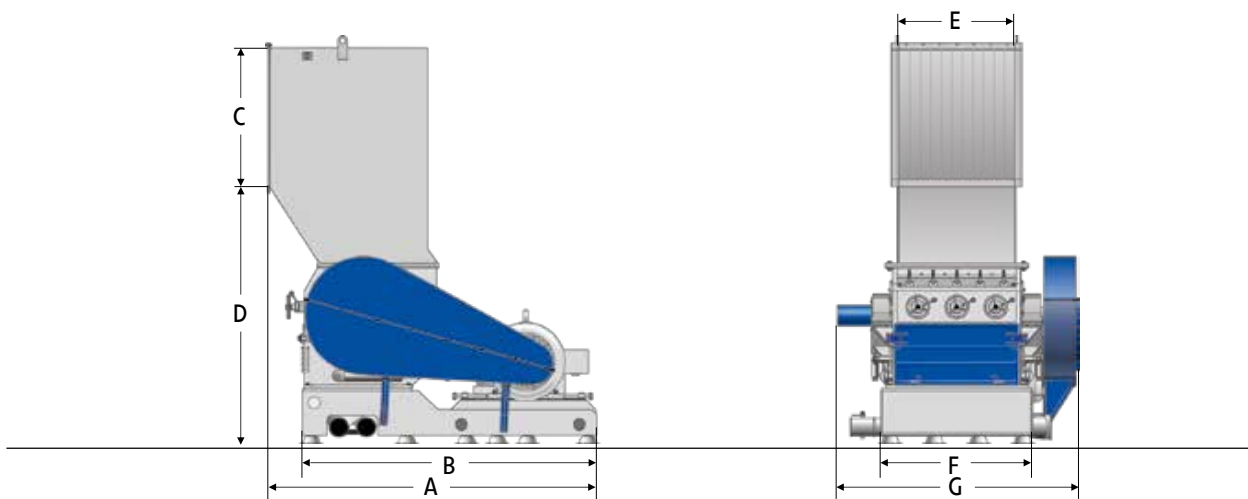

### Technical Specifications

Type	600/800	600/1600	700/1000
Rotor diameter (mm)	600	600	700
Rotor width (mm)	800	1600	1000
Drive capacity (kW)	75	132	90 / 110
Rotor knives (rows)	5 or 7	5 or 7	5 or 7 or 9
Stator blades (rows)	2 or 3	2 or 3	2 or 3
Screen size (mm)	> 6	> 6	> 8
Effective working area (mm)	790 x 695	1500 x 695	900 x 800
Weight approx. (kg)	4500	6950	7100

### Dimensions

Type	600/800	600/1600	700/1000
A (mm)	2350	2535	2830
B (mm)	2220	2390	2550
C (mm)	1000	1000	1100
D (mm)	1940	1940	2250
E (mm)	788	1560	985
F (mm)	1270	1980	1290
G (mm)	1820	2360	2060

# GSH 800

## Heavy duty granulators



- Knives are adjusted outside of the machine
- Specially developed deflector wedge
- Wide choice of rotors
- Well thought out housing design
- Strong Welded Steel construction
- Oversized outboard bearings

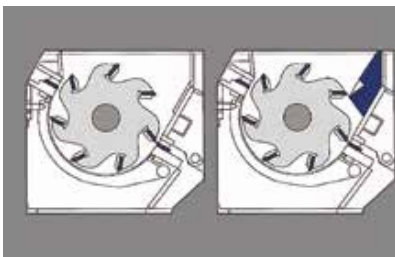

The easily removable deflector wedge acts as a third stator blade and can be used to adjust the aggressiveness of the rotor at the first cutting point.



The GSH granulators are available with different rotor options to fit different applications, all rotors feature the V-cut technology creating a high quality regrind.



For abrasive applications the GSH granulators can be equipped with rotors with key parts manufactured from highly wear resistant steel as well as weld on hard facing.

### Applications

The wide range of rotors and hopper styles allow the GSH machines to be tailored to almost every application in the plastic recycling field, mainly with high throughput requirements. The GSH 800 series can be used to grind large thick walled parts down to a granule in one step, or be used as a second step granulator after a ZXS shredder to reach very high throughput rates. For abrasive, contaminated or highly filled materials the machines can be equipped with special wear protections, such as hard facing of the rotor and housing and key parts manufactured from highly wear resistant steels.

### General Description

The heavy duty granulators of the GSH 800 series offer a wide array of different rotor designs with widths ranging from 1200 mm to 2000 mm with a diameter of 800 mm. The completely welded heavy steel construction is designed to withstand the most demanding and universal applications. Rotor bearings, knife mounts and rotor shaft are oversized. The standard V-cut creates a high quality regrind with a very low percentage of fines in the output material. The removable third stator blade is acting as a deflector wedge and allows the machine to be quickly adjusted to different application scenarios. Other standard features include easily replaceable wear plates in the cutting chamber as well as outboard bearings reducing the risk of contamination.

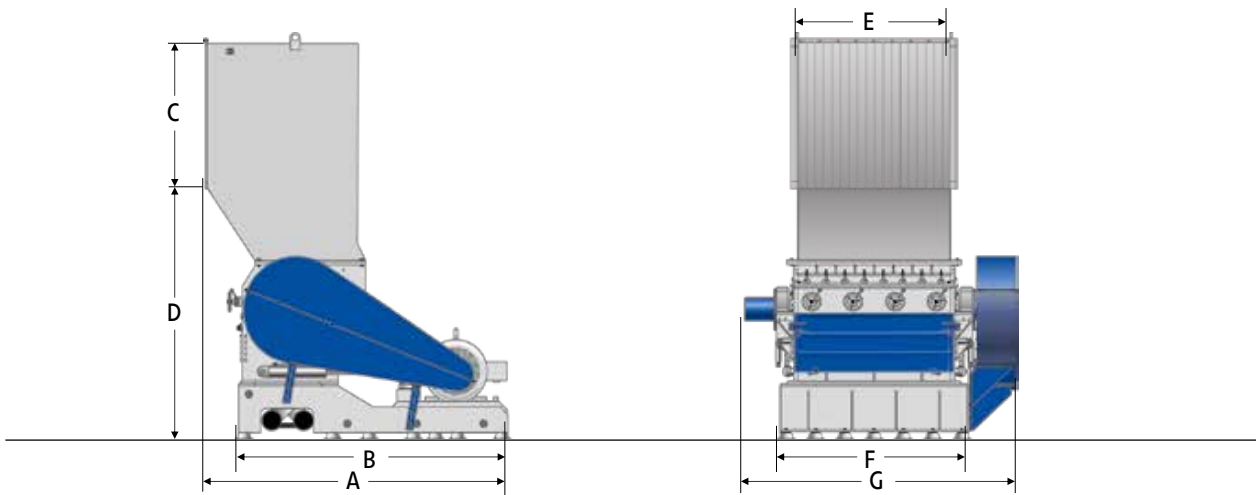

### Technical Specifications

Type	800/1200	800/1600	800/2000
Rotor diameter (mm)	800	800	800
Rotor width (mm)	1200	1600	2000
Drive capacity (kW)	132	160	2 x 160
Rotor knives (rows)	5 or 7 or 9	5 or 7 or 9	7 or 9
Stator blades (rows)	2 or 3	2 or 3	2 or 3
Screen size (mm)	> 8	> 8	> 8
Effective working area (mm)	1150 x 915	1570 x 915	1960 x 915
Weight approx. (kg)	10400	12500	13500

### Dimensions

Type	800/1200	800/1600	800/2000
A (mm)	3100	3175	3175
B (mm)	2800	2800	2800
C (mm)	1200	1400	1600
D (mm)	2250	2600	3055
E (mm)	1150	1570	1965
F (mm)	1535	1970	2250
G (mm)	2400	2860	3465

# GSH 1100



- Knives are adjusted outside of the machine
- Specially developed deflector wedge
- Wide choice of rotors
- Well thought out housing design
- Strong Welded Steel construction
- Oversized outboard bearings

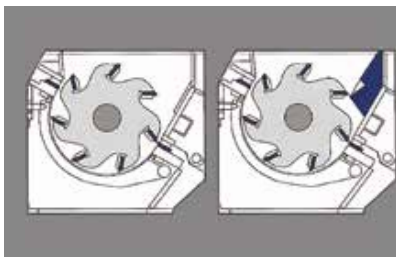

The easily removable deflector wedge acts as a third stator blade and can be used to adjust the aggressiveness of the rotor at the first cutting point.

## Applications

The GSH 1100 series of heavy duty granulators is a dependable machine engineered for demanding high throughput applications. The GSH 1100 series can be used to grind large thick walled parts down to a granule in one step, or be used as a second step granulator after a ZXS shredder to reach very high throughput rates. The large diameter rotors are available with a choice of 7, 9 or 11 rows of rotor knives. The V-cut design ensures a high quality granule with a low percentage of fines. For abrasive, contaminated or highly filled materials the machines can be equipped with special wear protections, such as hard facing of the rotor and housing and key parts manufactured from highly wear resistant steels.



The granulators can be tailored to fit various applications, for example with oversized suction troughs in order to achieve a very high output.



The GSH 1100 series comes standard with wide H-style rotors available with 9, 11 or 13 rows of rotor blades ensuring a high quality output.

## General Description

The heavy duty granulators of the GSH 1100 series offer different rotor configurations with widths ranging from 1200 mm to 2400 mm with a diameter of 1100 mm. The completely welded heavy steel construction is designed to with-stand the most demanding and universal applications. Rotor bearings, knife mounts and rotor shaft are oversized. The standard V-cut creates a high quality regrind with a very low percentage of fines in the output material. The remov-able third stator blade is acting as a deflector wedge and allows the machine to be quickly adjusted to different application scenarios. Other standard features include easily replaceable wear plates in the cutting chamber as well as out-board bearings reducing the risk of contamination.



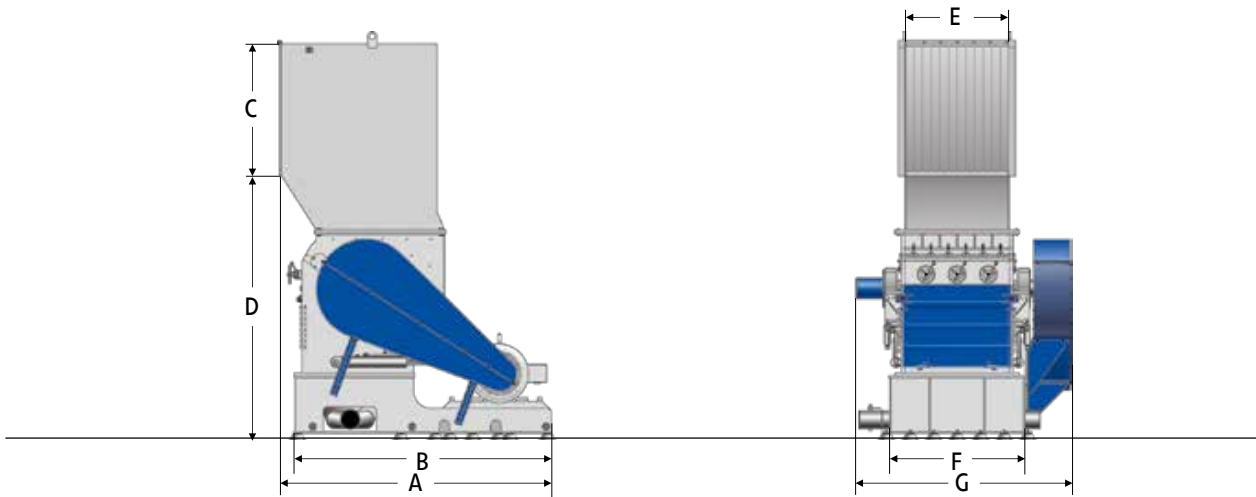

### Technical Specifications

Type	1100/1200	1100/2400
Rotor diameter (mm)	1100	1100
Rotor width (mm)	1200	2400
Drive capacity (kW)	200	2 x 200
Rotor knives (rows)	7 or 9 or 11	7 or 9 or 11
Stator blades (rows)	2 or 3	2 or 3
Screen size (mm)	> 8	> 8
Effective working area (mm)	1150 x 1210	1960 x 1210
Weight approx. (kg)	14000	22000

### Dimensions

Type	1100/1200	1100/2400
A (mm)	3115	3115
B (mm)	3000	3000
C (mm)	1400	1400
D (mm)	3030	3030
E (mm)	1150	2300
F (mm)	1680	2760
G (mm)	2440	3830

# GSP

## Pipe- / profile granulators



- Knives are adjusted outside of the machine
- Specially developed deflector wedge
- Wide choice of rotors
- Well thought out housing design
- Strong Welded Steel construction
- Oversized outboard bearings



Rotor and stator knives are pre-set outside the machine prior to installation in a supplied fixture. This makes awkward adjustment inside the machine unnecessary.

### Applications

Conventional granulators have substantial problems handling long pipes and profiles. To feed large and bulky parts, in most cases, cavities or platforms are needed. Therefore ZERMA developed the GSP range. Thanks to the almost level feeding hopper, long pieces can be fed easily. While the machine is operating there is no risk of blocking, in case of congestion no more material will be accepted by the machine until the grinding chamber is empty and the machine will accept material again, and work continues.



The specially angled rotor automatically pulls the fed pipes or profiles into the cutting chamber. This design also regulates the amount of material.



The heavy duty bearings are separated from the cutting chamber to avoid lubricants entering the cutting chamber and bearing failure due to material contamination in the bearings.

### General Description

The Pipe and Profile Granulators of the GSP series are available in rotor widths of up to 1400 mm and diameters ranging from 560 to 700 mm. The completely welded heavy steel cutting chamber is angled and fitted with an extended hopper to allow easy feeding of parts. The standard V-cut creates a high quality regrind with a very low percentage of fines in the output material. Other standard features include a hydraulically opened hopper for outboard bearings reducing the risk of contamination.

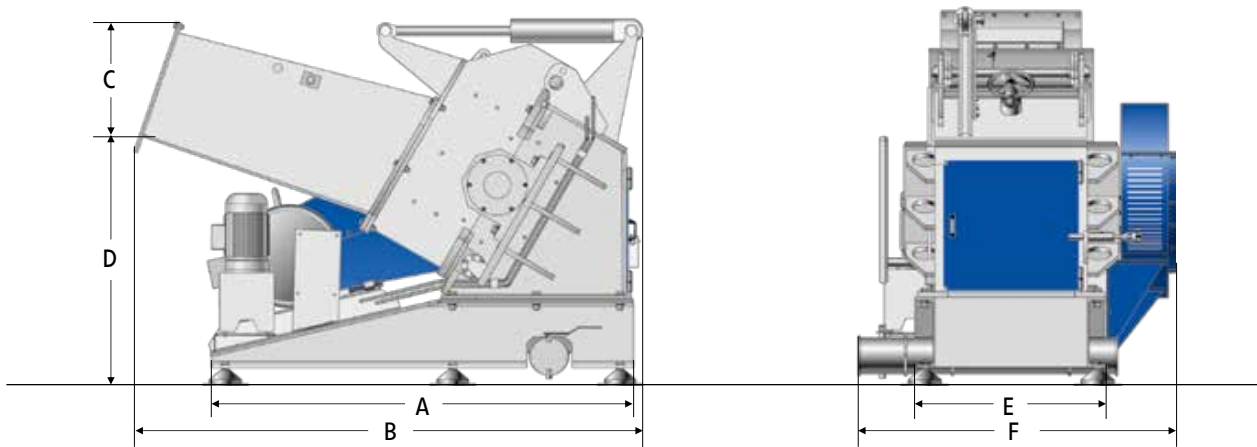

### Technical Specifications

Type	600/500	560/700	560/1000	700/1400
Rotor diameter (mm)	600	560	560	700
Rotor width (mm)	500	700	1000	1400
Drive capacity (kW)	45	55	75	90
Rotor knives (rows)	5	5 / 7	5 / 7	5 / 7
Stator blades (rows)	2	2	2	2
Screen size (mm)	> 8	> 8	> 8	> 8
Effective working area (mm)	440 x 530	290 x 740	290 x 1010	320 x 1440
Weight approx. (kg)	4000	5000	6400	9000

### Dimensions

Type	600/500	560/700	560/1000	700/1400
A (mm)	1940	2290	2290	2420
B (mm)	2245	2400	2450	2580
C (mm)	440	220	220	300
D (mm)	1040	1250	1250	1255
E (mm)	940	1170	1380	1840
F (mm)	1350	1785	2060	2400

# ZBS

## Compact shredder



- Affordable solution for small lumps
- Simple upgrade for existing granulation system
- Easy to move and place
- Tangential infeed avoids the need for a hydraulic pusher
- Small footprint
- Low energy consumption

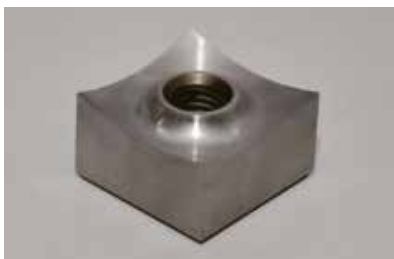

The shredders use concave ground square knives, producing high quality output. The cutters can be turned after a side is worn out.

### Applications

The ZBS shredders have been designed for in house recycling of small lumps and purges from injection and blow molding processes. The typical input materials are small and medium sized cakes such as head waste. The material can be shred to reduce the volume or processed further in a granulator to be re introduced into the production process immediately. The machine also can be used to destroy sensitive products or to recycle small batches of low volume products to avoid contamination of the main product line.



All ZERMA shredders are equipped with our E-style flat rotor. The knives are fixed in special knife holders fitted in machined pockets.

### General Description

The ZBS series shredders are single shaft shredders with a tangential infeed to eliminate the need for a hydraulic feeding system. The space saving and maneuverable design combined with the 'plug and play' controls make this machine very flexible and ready to go in no time. Like its bigger brothers in the ZS series they are equipped with outboard bearings, 310 mm diameter flat E rotors with 600 or 850 mm width driven by an oversized geared motor. Utilizing the proven ZERMA knife holder and knife design. The user friendly design makes cleaning and maintenance work a breeze. The low speed of 60 rpm combined with the compact design of the ZBS shredders makes it possible to shred lumps at a relatively low noise level. The machines can be fed manually or by conveyor, material discharge can be done via conveyor or into a drop box.



The ZBS shredders feature an aggressive tangential infeed for easy feeding without the need for a hydraulic system. Lumps of up to 400 mm diameter can be processed easily in this machine series.

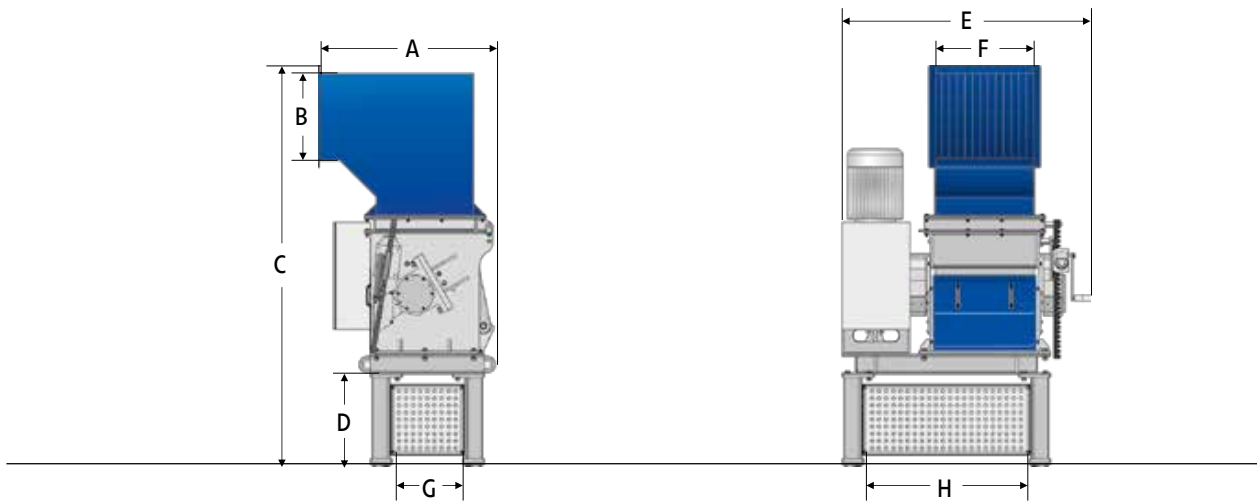

### Technical Specifications

Type	600	850
Rotor diameter (mm)	310	310
Rotor width (mm)	560	840
Rotor speed (rpm)	61	61
Drive capacity (kW)	11	18.5
Rotor knives (pcs)	26	40
Stator blades (rows)	1	1
Screen size (mm)	> 16	> 16
Effective working area (mm)	490 x 550	490 x 830
Weight approx. (kg)	1400	1500

### Dimensions

Type	600	850
A (mm)	995	1045
B (mm)	490	490
C (mm)	2255	2255
D (mm)	525	525
E (mm)	1400	2080
F (mm)	550	830
G (mm)	420	470
H (mm)	950	1200

# ZSS / ZPS



## General purpose shredders

- Multiple rotor designs and materials
- Low speed, high torque geared drive
- Powerful hydraulic swing type pusher (ram)
- Smaller footprint compared to traditional horizontal pusher style shredders
- Bolt-in drive shafts
- Two speed hydraulic system as standard
- ZPS with a higher ram feeder

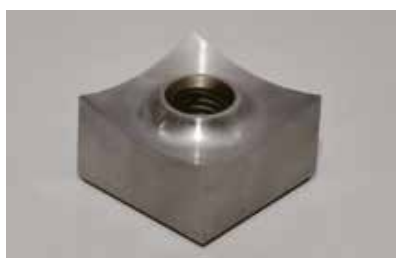

The shredders use concave ground square knives, producing high quality output. The cutters can be turned after a side is worn out.

### Applications

The ZSS / ZPS shredders have been designed for a wide array of applications and industries like in house and general recycling, electronic waste and post consumer waste handling. Input materials can be all kinds of plastics like lumps, pipes, film, woven bags; electronic waste like cables and ICBs, paper, wood and other organic materials. Depending on input material and the following process the shredded material as defined by the used screen size can be directly used or go into the next step of size reduction for example in a GSH granulator



The ZSS series shredders benefit from sturdy ram construction incorporating heavy duty guide bearings and universal couplings for reliable operation.

### General Description

The ZSS / ZPS shredders are single shaft shredders with a powerful two speed swing ram design eliminating the risk of blocking and wearing out of internal guide rails. The machine is very versatile and can be used for shredding of all kinds of input materials and is well suited for different industries. The 457 mm diameter rotors ranging from 850 to 2000 mm width are driven by one or two oversized gearboxes. The hydraulic power pack is well integrated into the machine housing to save space and protect it from damage but still easy to access or remove for maintenance. The standard E rotor features the proven ZERMA knife and knife holder design, as well as outboard bearings and a hydraulically operated screen cradle. The machines can be tailored to various applications with cooling or hard facing and other wear options



All ZERMA shredders are equipped with a large diameter flat rotor. The knives are fixed in special knife holders fitted in machined pockets. Optional weld on hard facing is available for abrasive applications.

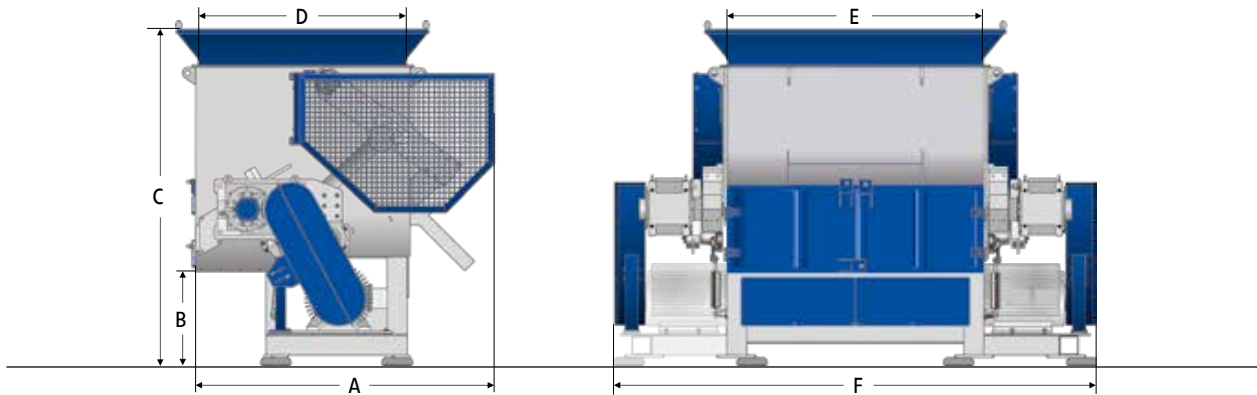

### Technical Specifications

Type	850	1200	1500	2000
Rotor diameter (mm)	457	457	457	457
Rotor width (mm)	850	1200	1500	2000
Rotor speed (rpm)	74	74	74	74
Drive capacity (kW)	37 / 55	55 / 75	75 / 90	2 x 55 / 2 x 75
Rotor knives (pcs)	40 / 60	54 / 81	68 / 102	96 / 144
Stator blades (rows)	1	1	1	1
Ram feeder drive (kW)	5.5	5.5	5.5	5.5
Screen size (mm)	> 40	> 40	> 40	> 40
Cutting chamber volume (m <sup>3</sup> )	1.37	1.82	2.27	3.16
Effective working area (mm)	800 x 770	800 x 1050	800 x 1330	800 x 1890
Weight approx. (kg)	5100	5900	6600	8600

### Dimensions

Type	850	1200	1500	2000
A (mm)	2300	2300	2300	2300
B (mm)	725	725	725	725
C (mm)	2795	2795	2795	2795
D (mm)	1590	1590	1590	1590
E (mm)	840	1120	1400	1960
F (mm)	2010	2290	2610	3760

# ZIS

## Shredders for voluminous parts



- 35 % more internal volume compared to the ZSS series
- Internal hydraulic pusher (ram)
- Variable speed, faster pusher movement
- Smaller footprint compared to traditional horizontal pusher style shredders
- All advantages of the conventional ZSS series

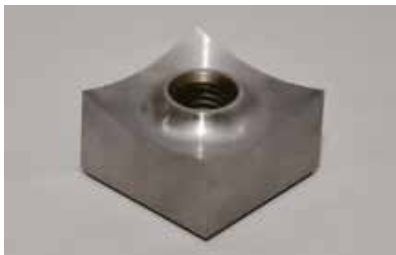

The shredders use concave ground square knives, producing high quality output. The cutters can be turned after a side is worn out.

### Applications

The ZIS shredders have been designed to handle voluminous parts such as IBCs, wheelie bins, pallets, large drums etc but also retain the versatility and flexibility to be used for general recycling in the plastic and wood industry.



The internal ram design on the ZIS series allows the cutting chamber volume to be increased while keeping a small footprint making the ZIS ideal for shredding of big volume parts.

### General Description

The ZIS series shredders are single shaft shredders with a large internal volume. The redesigned hydraulic pusher system creates about 35% more space in the cutting chamber while increasing the power and speed of the ram itself. The machines are equipped with a 457 mm diameter ZERMA E rotor with widths ranging from 1200 to 2000 mm. As on the ZSS machines the rotor is driven via an oversized gearbox. The completely closed welded steel housing increases the stability and avoids material spillage. The ZIS inherits all of the advantages of the ZERMA knife and knife holder design as well as standard features such as outboard bearings, hydraulic screen cradle, easy maintainability and advanced controls.

As with all ZERMA shredders, the ZIS range can be equipped with a wear package for the processing of highly abrasive, filled materials.



All ZERMA shredders are equipped with a large diameter flat rotor. The knives are fixed in special knife holders fitted in machined pockets. Optional weld on hard facing is available for abrasive applications.



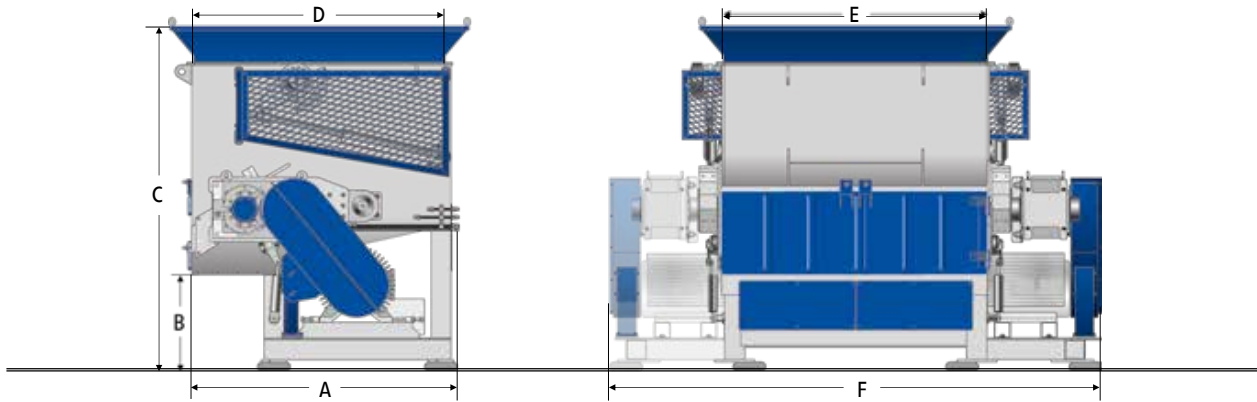

### Technical Specifications

Type	1200	1500	2000
Rotor diameter (mm)	457	457	457
Rotor width (mm)	1130	1410	1970
Rotor speed (rpm)	74	74	74
Drive capacity (kW)	55	75	2 x 55
Rotor knives (pcs)	54 / 81	68 / 102	96 / 144
Stator blades (rows)	1	1	1
Ram feeder drive (kW)	5.5	5.5	5.5
Screen size (mm)	> 40	> 40	> 40
Cutting chamber volume (m <sup>3</sup> )	2.15	2.7	3.75
Effective working area (mm)	1400 x 1010	1400 x 1290	1400 x 1850
Weight approx. (kg)	5000	6400	8800

### Dimensions

Type	1200	1500	2000
A (mm)	2070	2070	2070
B (mm)	725	725	725
C (mm)	2600	2600	2600
D (mm)	1880	1880	1880
E (mm)	1140	1420	1980
F (mm)	2320	2635	3710

# ZHS

## Shredders



- Large feeding hopper
- Robust welded steel construction
- Low speed operation
- Advanced rotor / knife mounting system



The large feeding hopper allows the machine to be used for a variety of materials.



The rotors are equipped with square knives, producing high quality output. The cutters can be turned after they are worn.



Angled hydraulic pusher to ensure optimal material feeding and ingestion.

### Applications

The ZHS series of single shaft shredders are mainly used in the industry to achieve a economic recycling of plastics to wood, paper, and general waste streams. The machines have been engineered for strength and reliability in daily operation. These shredders can easily be integrated into complete lines with other **ZERMA** products and accessories such as belts, granulators, etc.

### General Description

**ZERMA** ZHS shredders are single shaft shredders featuring an angled hydraulic ram suitable for a wide range of material shapes and sizes. The ZHS shredders are equipped with a **ZERMA** E style rotor and knife holder fixing system. The final size of the material is determined by the screen which can easily be changed based on requirements. The ZHS shredder can be tailored to individual requirements, this includes different drive powers, knife configurations as well as discharge options.

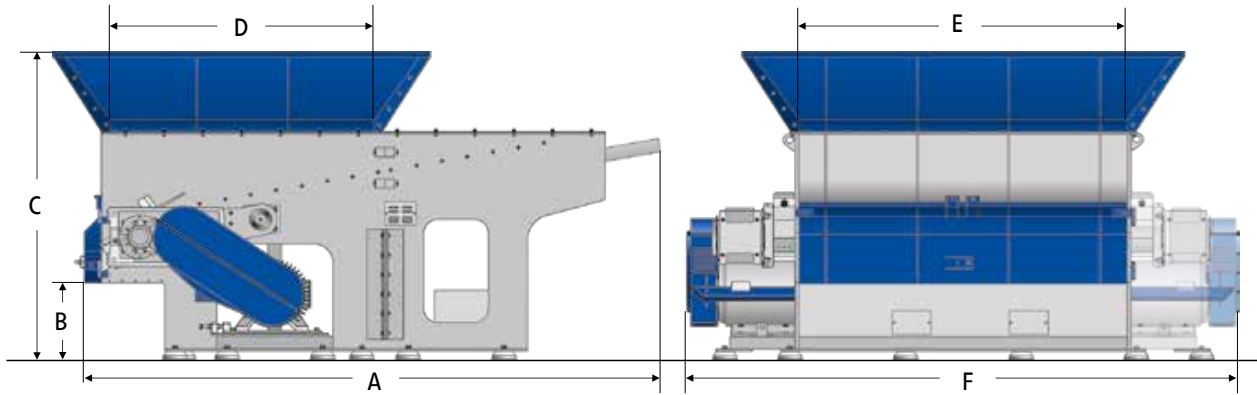

### Technical Specifications

Type	850	1100	1400	1700	2000
Rotor diameter (mm)	404	404	404	404	404
Rotor width (mm)	850	1100	1400	1700	1960
Rotor speed (rpm)	100	100	104	104	104
Drive capacity (kW)	22 / 30	30 / 37	45 / 55	55 / 75	75 / 90
Rotor knives (pcs)	20 / 40	27 / 54	34 / 68	41 / 82	48 / 96
Stator blades (rows)	1	1	1 x 5	1 x 6	1 x 7
Ram feeder drive (kW)	1.5	1.5	5.5	5.5	5.5
Screen size (mm)	> 40	> 40	> 40	> 40	> 40
Cutting chamber volume (m <sup>3</sup> )	1.25	2	3.6	4.7	5.5
Effective working area (mm)	820 x 770	1095 x 1050	1440 x 1330	1640 x 1610	1620 x 1910
Weight approx. (kg)	3000	3700	6000	7000	8500

### Dimensions

Type	850	1100	1400	1700	2000
A (mm)	2690	3160	3990	4325	4205
B (mm)	455	455	455	455	455
C (mm)	2025	2135	2320	2370	2420
D (mm)	1285	1540	1885	2050	2050
E (mm)	860	1140	1420	1700	1980
F (mm)	1565	2085	2370	2730	3075

# ZHS+

## Shredders



- Large feeding hopper
- Robust welded steel construction
- Low speed operation
- Advanced rotor / knife mounting system



The large feeding hopper allows the machine to be used for a variety of materials.

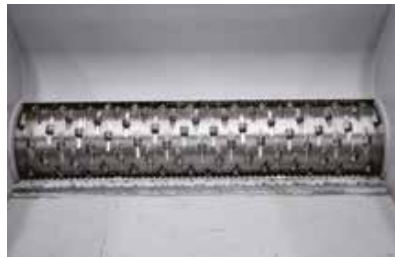

The rotors are equipped with square knives, producing high quality output. The cutters can be turned after they are worn.



Angled hydraulic pusher to ensure optimal material feeding and ingestion.

### Applications

The ZHS series of single shaft shredders are mainly used in the industry to achieve a economic recycling of plastics to wood, paper, and general waste streams. The machines have been engineered for strength and reliability in daily operation. These shredders can easily be integrated into complete lines with other ZERMA products and accessories such as belts, granulators, etc.

### General Description

ZERMA ZHS shredders are single shaft shredders featuring an angled hydraulic ram suitable for a wide range of material shapes and sizes. The ZHS shredders are equipped with a ZERMA E style rotor and knife holder fixing system. The final size of the material is determined by the screen which can easily be changed based on requirements. The ZHS shredder can be tailored to individual requirements, this includes different drive powers, knife configurations as well as discharge options.

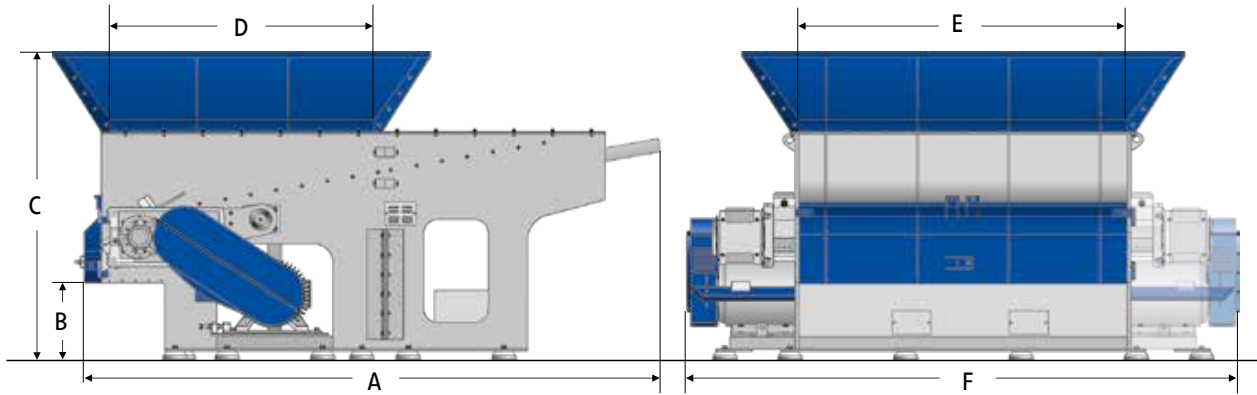

### Technical Specifications

Type	1500	2000	2600
Rotor diameter (mm)	600	600	600
Rotor width (mm)	1400	1960	2520
Rotor speed (rpm)	104	104	104
Drive capacity (kW)	90 / 110	110 / 2 x 75	2 x 90 / 2 x 110
Rotor knives (pcs) D (34 X 34)	68 / 102	96 / 144	124 / 186
Rotor knives (pcs) D (50 X 50)	38 / 57	54 / 81	70 / 105
Stator blades (rows)	1 x 5	1 x 9	1 x 9
Ram feeder drive (kW)	5.5	5.5	5.5
Screen size (mm)	> 40	> 40	> 40
Cutting chamber volume (m <sup>3</sup> )	3.6	5.5	7.2
Effective working area (mm)	1400 x 1340	1880 x 1550	2440 x 1550
Weight approx. (kg)	12000	14000	16000

### Dimensions

Type	1500	2000	2600
A (mm)	4420	4650	4650
B (mm)	455	455	595
C (mm)	2700	2740	2740
D (mm)	1885	2050	2040
E (mm)	1420	1980	2540
F (mm)	2840	3870	4425

# ZXS

## Heavy duty shredders



- Low speed, high torque gear drive
- Powerful two speed hydraulic swing type ram
- Heavy Duty design
- High throughput rates
- Suitable for very large and heavy parts
- Large diameter rotor (750 mm)



The shredders use concave ground square knives, producing high quality output. The cutters can be turned after a side is worn out.

### Applications

The ZXS shredders have been designed for the most demanding and high throughput applications in recycling industries. The input materials can be all types of plastics, wood, paper, cardboard, e-waste, post consumer waste, rubber, etc. in various shapes and sizes. Typical input materials are: fridges, purges, tires, pallets, bales, drums and barrels, pipes, film etc... The output material size is determined by the installed screen size and, except in some RDF (refuse derived fuels) and wood applications, the output material may need to be processed further to achieve the desired final size. For the recycling of complete truck and tractor tires the ZXS T model is configured with special wear protection and knives.



All ZERMA shredders are equipped with a large diameter flat rotor. The knives are fixed in special knife holders fitted in machined pockets. Optional weld on hard facing is available for abrasive applications.

### General Description

The ZXS shredders are single shaft shredders with a powerful two speed swing ram design eliminating the risk of blocking and wearing out of internal guide rails. The machine is very versatile and can be used for shredding of all kinds of input materials and is well suited for different industries. The 750 mm diameter rotors ranging from 1500 to 3000 mm width are driven by two oversized gearboxes. The low speed of 45 rpm guarantees a high torque and smooth operation.

The hydraulic power pack is well integrated into the machine housing to save space and protect it from damage but still easy to access or remove for maintenance. The proven E rotor, knife holder and knife designs are taken to new dimensions to conquer the most demanding applications and challenges. The machines can be tailored to various applications with advanced controls and hydraulics, hard facing and other wear options.



The ZXS shredders feature a high powered twin speed hydraulic system. This system ensures maximum pressure when feeding material into the rotor and high speeds on the backstroke.

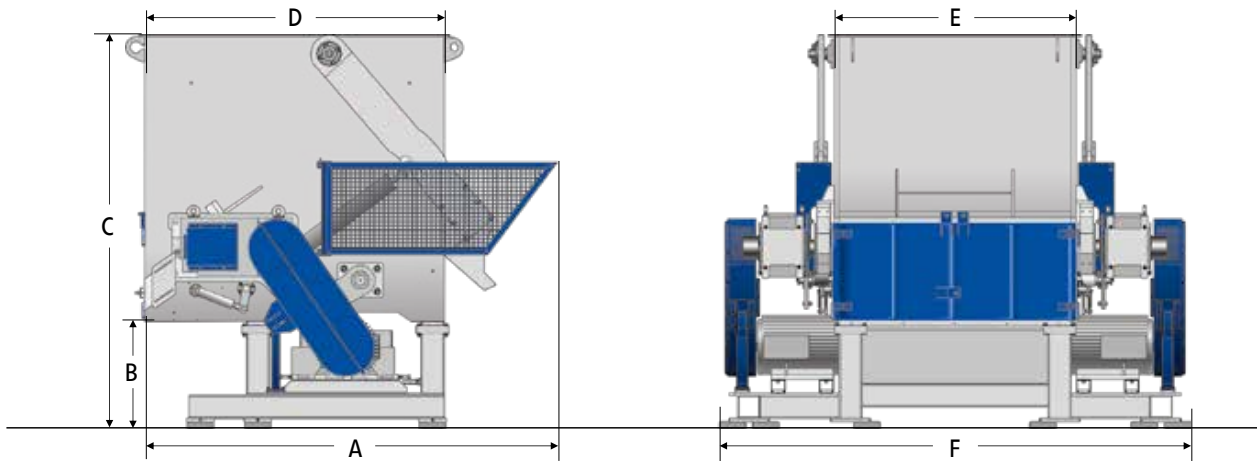

### Technical Specifications

Type	1500	2000	3000
Rotor diameter (mm)	750	750	750
Rotor width (mm)	1500	2000	3000
Rotor speed (rpm)	46	46	46
Drive capacity (kW)	2 x 75	2 x 90	2 x 132
Rotor knives (pcs)	76	96	136
Stator blades (rows)	1	1	1
Ram feeder drive (kW)	11	11	11
Screen size (mm)	> 60	> 60	> 60
Cutting chamber volume (m <sup>3</sup> )	7.75	9.67	13.5
Effective working area (mm)	1500 x 1440	1500 x 1840	1500 x 2640
Weight approx. (kg)	17500	20000	25000

### Dimensions

Type	1500	2000	3000
A (mm)	3580	3580	3580
B (mm)	935	935	1015
C (mm)	3420	3420	3670
D (mm)	2540	2540	2540
E (mm)	1620	2020	2820
F (mm)	3560	4100	5070

# ZRS

## Pipe / profile shredders



- Allows feeding of bundles or nested pipes and profiles
- No pre cutting of pipe lengths necessary
- Process pipes up to 1200 mm diameter
- Automatic control giving virtually risk free operation
- Elimination of amperage peaks
- High throughput rates
- Large diameter rotor (up to 1500 mm)

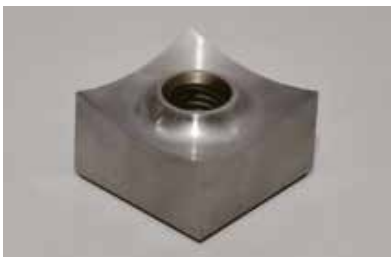

The shredders use concave ground square knives, producing high quality output. The cutters can be turned after a side is worn out.



The ZRS shredders use very large diameter flat E-style rotors. The knives are fixed in special knife holders fitted in machined pockets.



The ZRS pipe shredders are equipped with a special feeding trough sized to take pipes of up to 6 m length. A powerful hydraulic ram forces the pipes into the rotor.

### Applications

The main focus of the ZRS shredders is the shredding of large diameter pipes or bundles of smaller pipes and profiles made from HDPE, PP and PVC. The machines can also be used for recycling of other plastic materials such as large lumps, stacked wheelie bins and pallets etc. In combination with other ZERMA size reduction equipment such as granulators and pulverizers we are able to provide a complete turn-key recycling solution.

### General Description

The ZRS shredder is the world's first single shaft shredder capable of handling large diameter pipes (up to 1200mm diameter) without the need for pre-cutting. Since their introduction they have become the virtual standard for pipe shredding and are used world-wide by leading pipe manufacturers. More than 200 installations demonstrate our technological leadership in this market and our continuing innovation is based on market demands and customer feedback. Dependent on pipe diameter, the ZRS rotor diameters and widths range from 800mm up to 1500 mm. The standard hopper accepts pipe lengths of up to 6 m. The combination of advanced controls, low rotor speed and smooth hydraulics create a reliable and easy to use system.



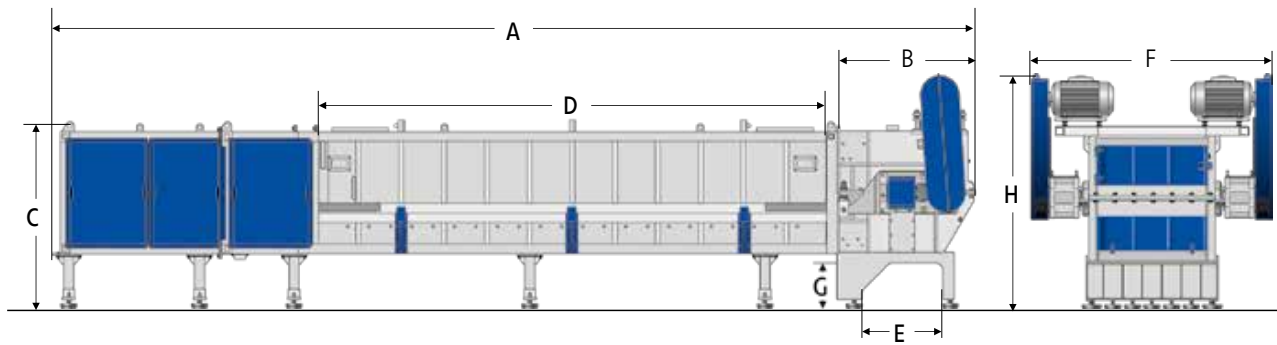

### Technical Specifications

Type	800	1000	1500
Rotor diameter (mm)	800	1000	1500
Rotor width (mm)	850	1050	1450
Rotor speed (rpm)	40	36	23
Drive capacity (kW)	2 x 37	2 x 45	2 x 55
Rotor knives (pcs)	60	81	136
Stator blades (rows)	1 or 2	1 or 2	1 or 2
Ram feeder drive (kW)	11	15	15
Feeding trough volume (m <sup>3</sup> )	2.7	6.7	12.6
Biggest pipe (mm)	6500/3500 x 630	6500 x 850	6500 x 1200
Weight approx. (kg)	12800	17500	24000

### Dimensions

Type	800	1000	1500
A (mm)	11840	11940	12180
B (mm)	1420	1580	1820
C (mm)	1830	1965	2320
D (mm)	3860	6720	6720
E (mm)	975	1080	1080
F (mm)	2545	2975	3290
G (mm)	590	590	590
H (mm)	2565	2660	3160

# ZTS/ZTTS

## Shredders for car tires



- Single large diameter rotor (760 mm)
- Proprietary knife design and material
- Variable knife gap to improve separation of steel and rubber
- Compact Heavy Duty design
- High throughput rates
- Fast and easy tool change and maintenance



The ZERMA tire shredders use special highly wear resistant tungsten carbide flat knives. These knives ensure a long lifetime working with abrasive and contaminated materials.



The oversized gearbox driving the rotor is supported by a very sturdy torque arm cushioning the shocks created while grinding.



The ZTS and ZTTS shredders are equipped with a large diameter flat rotors with weld on hard facing. The knives are fixed in special knife holders fitted in machined pockets.

### Applications

The ZTS with its single row of stator knives is used to pre-shred complete car tires or large pieces of pre-reduced truck tires down to a size of approx. 150 mm. The twin rows of stator knives and screen in the ZTTS enable it to process the tire shreds down to any required size > 20 mm. The unique machine design combined with the variable cutting gap create an optimal separation of rubber and steel fractions when the machine is used with 20 mm screen. Therefore steel can be removed easily in the following process with magnetic separation equipment. The machines are also used in the processing of RDF and other alternative fuel applications.

### General Description

The ZTS and ZTTS single shaft shredders are specially designed for the pre-processing of complete or pre-shred tires. Both machines feature a 750 mm diameter rotor with width options 1500 mm to 3000 mm with oversized outboard bearings and twin gear drives. The tangential infeed ensures optimal feeding of the input materials while eliminating the need for a hydraulic feeding system. All tire shredders are equipped with a complete wear package including rotor hard facing plus special knives and wear plates made from highly wear resistant steel. The ZTS and ZTTS ranges differ in the number of stator knives and the screen sizes used. The modular design makes it easy to integrate either machine into existing installations.

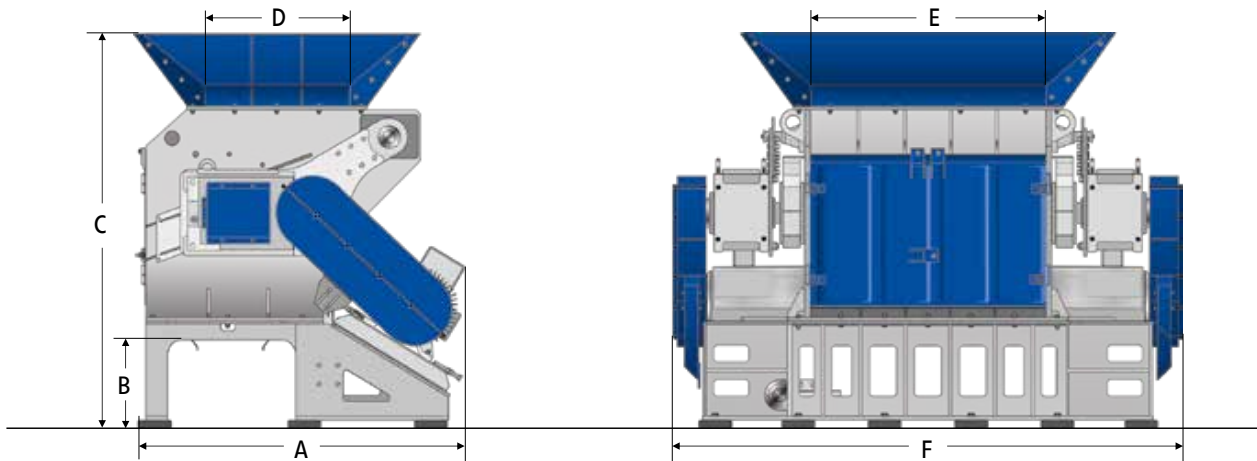

### Technical Specifications

Type	1500	2000	3000
Rotor diameter (mm)	760	760	760
Rotor width (mm)	1560	1960	2760
Rotor speed (rpm)	41	41	41
Drive capacity (kW)	2 x 90	2 x 110	on request
Rotor knives (pcs)	76	96	136
Stator blades (rows)	1 or 2	1 or 2	1 or 2
Screen size (mm) ZTS	80 mm screen bars	80 mm screen bars	80 mm screen bars
Screen size (mm) ZTTS	> 16	> 16	> 16
Effective working area (mm)	1005 x 1620	1005 x 2020	1005 x 2820
Weight approx. (kg) ZTS	12300	15300	20500
Weight approx. (kg) ZTTS	12800	16500	21500

### Dimensions

Type	1500	2000	3000
A (mm)	2300	2300	2300
B (mm)	605	605	605
C (mm)	2700	2700	2700
D (mm)	1000	1000	1000
E (mm)	1620	2020	2820
F (mm)	3800	4240	5040

# ZHM

## Hammer Mill



- Suitable for highly contaminated or abrasive materials
- Fixed hammer style
- Heavy Duty design
- High throughput rates
- Good disintegration of mixed input materials



The single piece tools used in the ZHM hammer mill are made from highly wear resistant steel, this increases their lifetime during heavy applications and makes changes quick and easy.

### Applications

ZERMA hammer mills were specially developed for materials that can not be crushed with conventional granulators or only with extremely high wear costs and risk of breakage. The current main application of the ZERMA ZHM is the processing of electronic waste, such as whole computers, white goods and ICBS. The main advantage of the ZHM in such processes lies in its tolerance of contamination and abrasive materials while being able to achieve relatively small sized output material thus allowing for efficient separation in downstream processes.

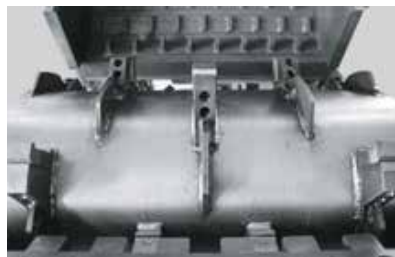

The ZHM hammer mill features a flat rotor with innovative welded tool holders. This heavy duty rotor design ensures a smooth operation on various materials.

### General Description

The ZHM series of hammer mills feature heavy duty rotors ranging from 600mm to 800 mm diameter and widths between 800mm and 1200 mm and with V-belt drive. The fixed rotor hammers acting against heavy duty fixed combs plus several rows of pre-breaker combs create high impact powers and hence high throughput rates. Tool changes are fast and easy. All tools and wear parts are manufactured from highly wear resistant steel. The housing inherits all the advantages of the proven GSH granulator design, such as the diagonally divided cutting chamber and hydraulic screen cradle for easy maintenance and servicing. Choice of screen sizes allows for a wide range of applications and degrees of disintegration.



The combination of pre breakers and counter knives create a high impact power resulting in a high degree of disintegration and high throughput rates.

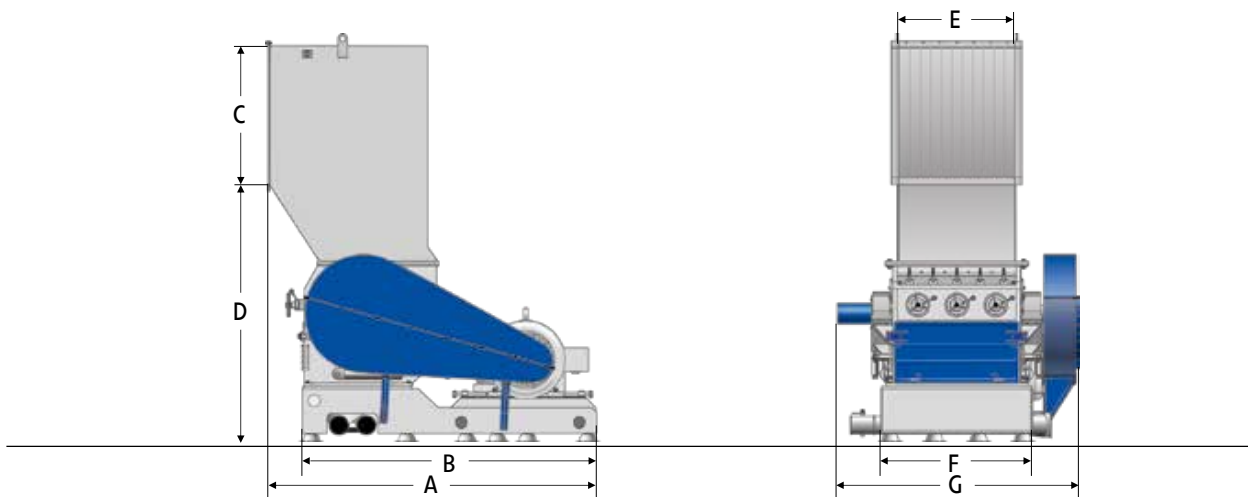

### Technical Specifications

Type	600/800	800/1200
Rotor diameter (mm)	600	800
Rotor width (mm)	800	1200
Drive capacity (kW)	75	132
Rotor tools (rows)	18	18
Stator blades (rows)	2	2
Screen size (mm)	> 6	> 8
Effective working area (mm x mm)	788 x 555	1150 x 740
Weight (approx. kg)	4500	8200

### Dimensions

Type	600/800	800/1200
A (mm)	2350	3025
B (mm)	2100	2800
C (mm)	1000	1200
D (mm)	1940	2570
E (mm)	788	1140
F (mm)	1125	1535
G (mm)	1840	2430

# ZCS

## Shredder / Granulator Combination



- Compact space saving design
- Low noise emission
- Versatile size reduction concept
- Flexible discharge options

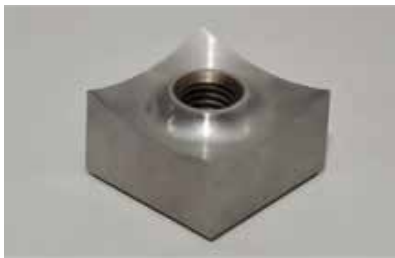

The ZCS machines rely on the proven E type rotor from the ZSS shredders with bolted knives and knife holders.



The ZCS system uses a sturdy roller guided drawer type ram to feed the material into the shredder. Segmented cutting chamber and ram allow trouble free processing of thin materials.



The granulator part uses a sturdy F+ rotor to ensure a good ingestion of the material flow while still being able to handle thicker and heavier particles.

### Applications

The ZCS system has been designed mainly for in-house use in blow and injection molding applications, yet it can be adopted in other fields too. The small foot print allows the system to be integrated into existing factory workshops easily. Being a closed system also reduces the risk of contamination compared to using a conveyor belt in a traditional two stage recycling system. The system is well suited for large volume parts and thicker materials such as flush or purging.

### General Description

The ZCS size reduction system combines a shredder with a granulator in a single space saving system for the processing of production waste. The shredder part is equipped with a 400mm diameter E rotor using ZERMA's proven knife and knife holder design, driven by a high-torque gear drive, which in comparison to a direct drive also handles tougher input materials well. The large material hopper and the powerful horizontal pusher allow processing of voluminous as well as heavier parts. The lower part of the system consists of a 3-blade granulator rotor based on the GST series. The shredder and granulator are matched to work together ideally and in conjunction with an advanced control system ensure smooth reliable operation.

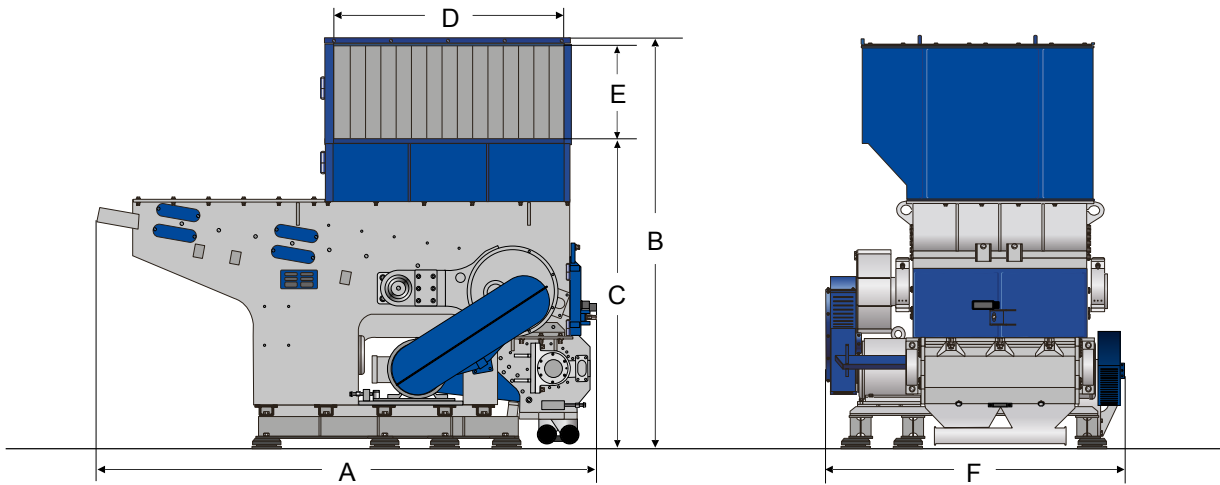

### Technical Specifications

Type	600	1000	1400
Feed opening	570 x 490	1500 x 600	1880 x 1000
Rotor width	570 mm	1000 mm	1400 mm
Rotor diameter (Shredder)	310 mm	400 mm	400 mm
Drive capacity (Shredder)	11 kW	30 kW	45 kW
Hydraulic drive capacity (Shredder)	0.75 kW	3.75 kW	3.75 kW
Rotor knives (Shredder)	26	27	34
Stator knives (Shredder)	1 x 2	1 x 4	1 x 5
Rotor diameter (Granulator)	300 mm	300 mm	350 mm
Motor capacity (Granulator)	7.5 kW	15 kW	22 kW
Rotor knives (Granulator)	3 x 2	3 x 2	3 x 2
Stator knives (Granulator)	2 x 1	2 x 1	2 x 1

### Dimensions

Type	600	1000	1400
A (mm)	1960	3348	4250
B (mm)	2370	2750	3410
C (mm)	1840	2080	2355
D (mm)	570	1538	1880
E (mm)	490	600	1000
F (mm)	1550~2540	1990	2500



## Close to our customers

The global ZERMA network of branches and distributors



### ZERMA

311 Era Drive • Northbrook, Illinois 60062  
Phone: 847-291-1300  
sales@zerma-america.com

[zerma.com](http://zerma.com)