

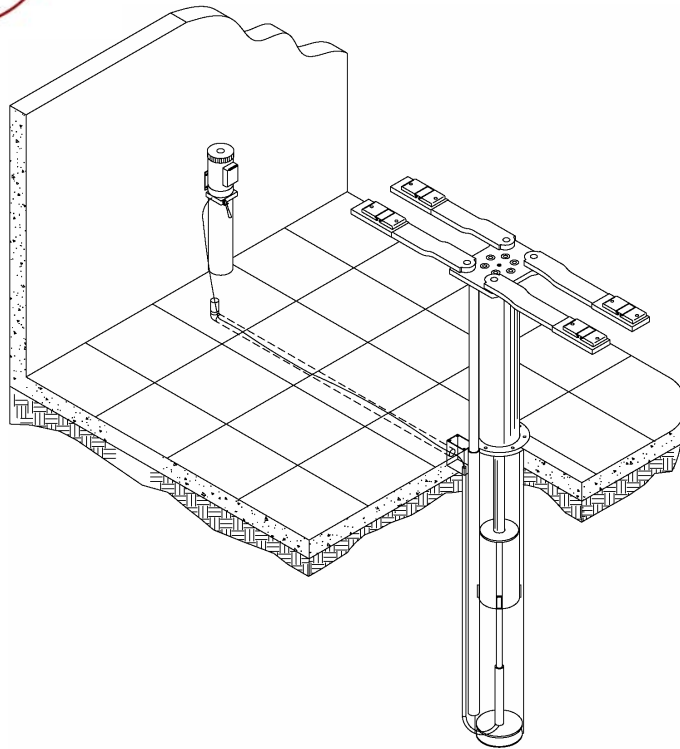

INSTALLATION and OPERATION MANUAL



9K SINGLE POST IN-GROUND HP19ES

**READ THIS INSTRUCTION MANUAL THOROUGHLY
BEFORE INSTALLING, OPERATING, SERVICING OR
MAINTAINING THE LIFT. SAVE THIS MANUAL.**



SAFETY AND OPERATING INSTRUCTIONS

1. When using this lift, basic safety precautions should always be followed, including the following.
2. Read all instructions in this manual and on the lift thoroughly before installing, operating, servicing or maintaining the lift.
3. Inspect lift daily. Do not operate lift if it malfunctions or problems have been encountered.
4. Never attempt to overload the lift. The manufacturer's rated capacity is shown on the identification label. Do not override the operating controls or the warranty will be void.
5. Before driving vehicle into lift area, position the arms to the drive-through position to ensure unobstructed clearance. Do not hit or run over arms as this could damage the lift and/or vehicle.
6. Only trained and authorized personnel should operate the lift. Do not allow customers or bystanders to operate the lift or be in the lift area.
7. Position the lift support pads to contact the vehicle manufacturers recommended lifting points. Raise the lift until the pads contact the vehicle. Check pads for secure contact with the vehicle. Check all arm restraints and insure they are properly engaged. Raise the lift to the desired working height.
8. Some pickup trucks may require an optional truck adapter to clear running boards or other accessories.
9. **NOTE:** Always use all 4 arms to raise and support vehicle.
10. **Caution! Never work under the lift unless the mechanical safety locks are engaged.**
11. Note that the removal or installation of some vehicle parts may cause a critical load shift in the center of gravity and may cause the vehicle to become unstable. Refer to the vehicle manufacturer's service manual for recommended procedures.
12. Always keep the lift area free of obstruction and debris. Grease and oil spills should always be cleaned up immediately.
13. Never raise vehicle with passengers inside.
14. Before lowering check area for any obstructions.
15. Before removing the vehicle from the lift area, position the arms to the drivethru position to prevent damage to the lift and or vehicle.
16. Do not remove hydraulic fittings while under pressure

For additional safety instructions regarding lifting, lift types, warning labels, preparing to lift, vehicle spotting, vehicle lifting, maintaining load stability, emergency procedures, vehicle lowering, lift limitations, lift maintenance, good shop practices, installation, operator training and owner/employer responsibilities, please refer to "Lifting It Right" (ALI/SM) and "Safety Tips" (ALI/ST).

For additional instruction on general requirements for lift operation, please refer to "Automotive Lift-Safety Requirements for Operation, Inspection and Maintenance" (ANSI/ALI ALOIM).

Installation shall be performed in accordance with ANSO/ALI ALIS, Safety Requirements for Installation and Service of Automotive Lifts.



ATTENTION! This lift is intended for indoor installation only. It is prohibited to install this product outdoors. Operating environment temperature range should be 41 – 104 °F (5 – 40 °C). Failure to adhere will result in decertification, loss of warranty, and possible damage to the equipment.

+ 070126-Quadra-WLSIA01

SAFETY INSTRUCTIONS

If attachments, accessories or configuration modifying components that are located in the

load path, affect operation of the lift, affect the lift electrical listing or affect intended vehicle accommodation are used on this lift and, if they are not certified for use on this lift, then the certification of this lift shall become null and void. Contact the participant for information pertaining to certified attachments, accessories or configuration modifying components.

www.autolift.org

©2007 by ALI, Inc.

ALI / WLSIA01

SPECIFICATIONS

Capacity:	9000 lbs.	4082 kg
Overall Width:	21½"	546 mm
Height to Lowered Lift Pads	4 ¼"	108 mm
Height to Lift Pad (3" Adapter):	6 ¾"	171 mm
Height to Lift Pad (6" Adapter):	9 ¼"	235 mm
Arm Extended Length:	41 ½"	1054 mm
Arm Retracted Length:	28"	711 mm
Maximum Lifting Height (6" Adapter):	74"	1880 mm
Power Requirements:	230 Volts AC, 1 Ph., 60 Hz.	

SHIPPING LIST:

- 1 Cylinder
- 1 Superstructure
- 1 Pumping Unit
- 1 16 ft. Pressure Hose
- 1 Wheel Spotting dish with bag of anchor bolts
- 4 1¼" x 4" Anchors Bolts for pumping unit
- 1 PVC Female Fitting
- 2 ½" X 1-¾" Flathead Allen Bolts for Retainer
- 2 7/8" Superstructure Bolts

BEFORE INSTALLING:

1. Handle cylinders with care. Dropping may damage bearings.
2. Check unit for shipping damage. Make any damage claims with carrier immediately. Contact factory to notify them of damage at 1-800-268-7959.
3. Check shipment against shipping list. Notify factory of missing parts immediately.

ELECTRICAL REQUIREMENTS

230V-60 Hz .Single Phase with 30 amp circuit protection

BAY REQUIREMENTS

A minimum of 12 feet front and rear and 7 feet to each side of cylinder center is recommended. A minimum of 70 inches between the lowest ceiling height obstruction and the roofline of the highest vehicle to be raised. 12 ft. of ceiling height is sufficient for passenger cars. (See Figure 1).

TOOLS REQUIRED:

1/4" Allen Wrench
1-7/16" Socket and Drive for superstructure nuts
1/4" Concrete Drill Bit
1 Tube Silicone Sealer
4 x 4 Wooden Planks or tripod crane
Forklift or tractor

CAUTION

DO NOT RAISE LIFT WITHOUT SUPERSTRUCTURES ATTACHED. THE PISTONS WILL COME OUT OF CASINGS AND MAY BE DIFFICULT TO LOWER WITHOUT THE WEIGHT OF THE SUPERSTRUCTURE ON THEM

WHEN BLEEDING CYLINDERS, DO NOT ALLOW INNER CYLINDERS TO ROTATE. THIS MAY CAUSE HOSE KINK.

**KEEP ALL LIQUIDS AWAY FROM LIFT
(water, cleaners, acids, etc)**

ANY LIQUID WHICH GETS INSIDE THE LIFTING UNIT WILL CAUSE INTERNAL DAMAGE AND WILL NOT BE COVERED UNDER WHEELTRONIC'S WARRANTY.

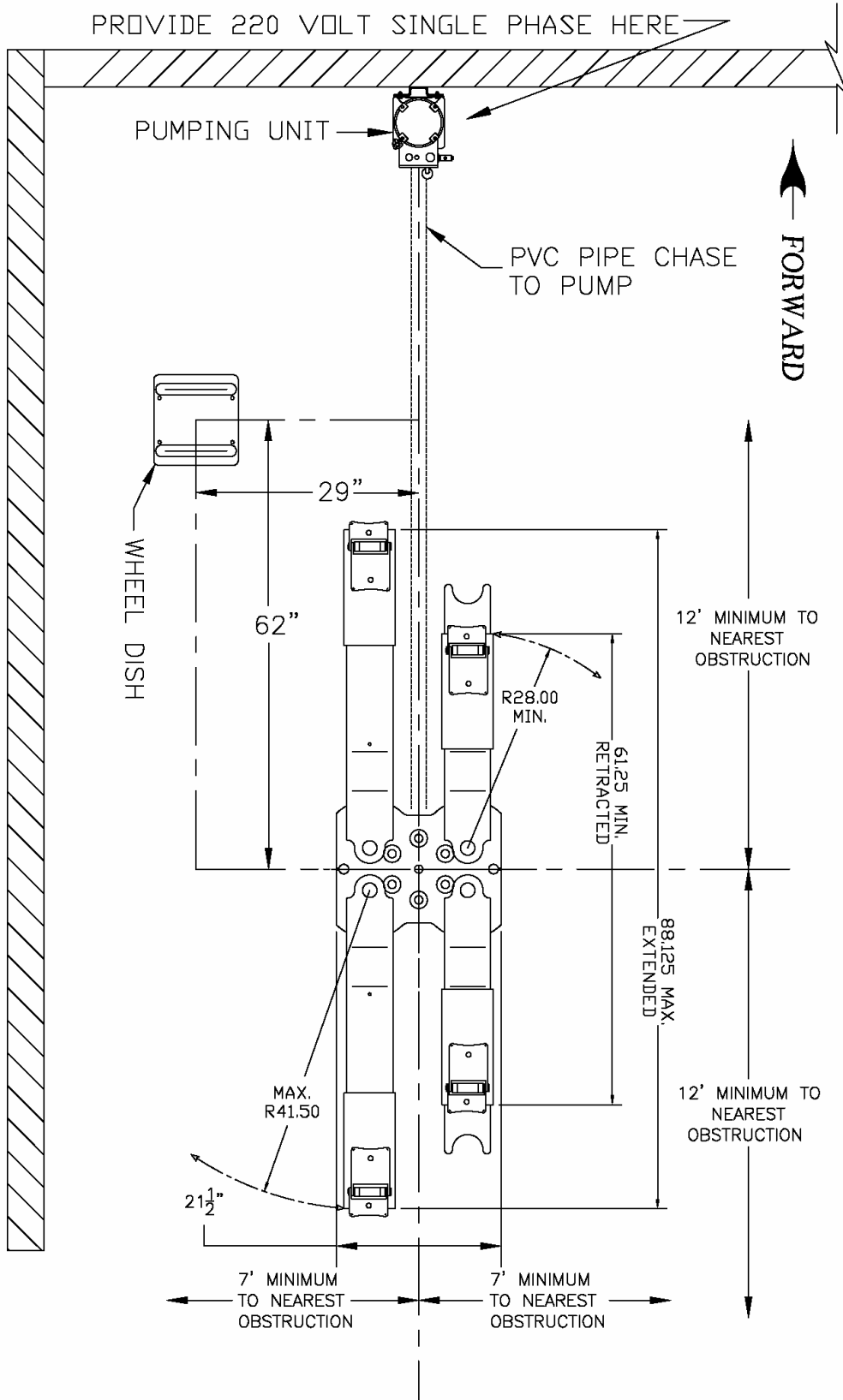

Figure 1 – Bay Layout

68" MAXIMUM STROKE

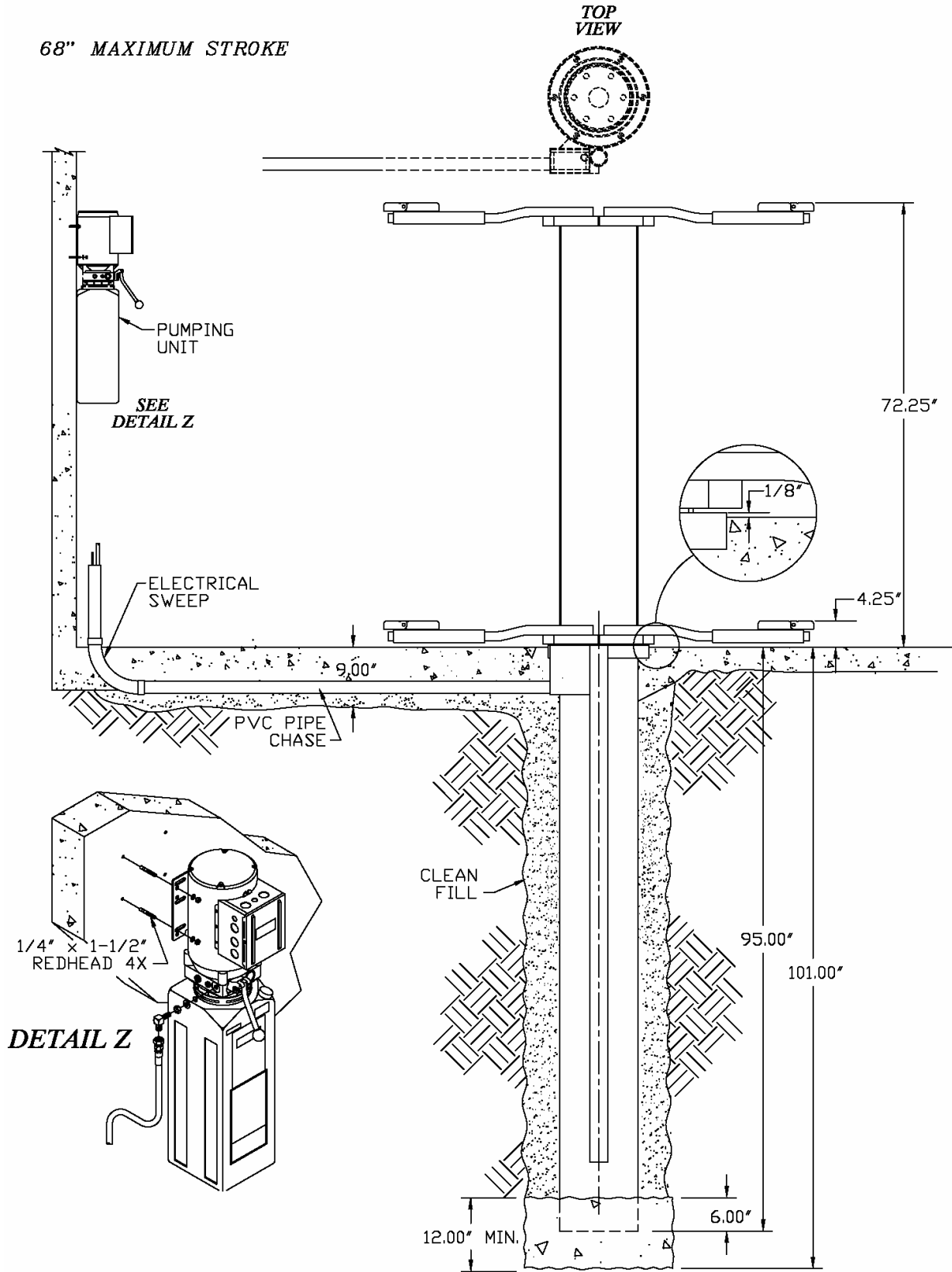

Figure 2 – Excavation

ELECTRICAL PUMP MOTOR: 230V 60Hz SINGLE PHASE

MOTOR OPERATING SPECIFICATIONS	
LINE VOLTAGE 208-230 VOLTS 60 HZ	RUNNING MOTOR VOLTAGE RANGE 200-245 VOLTS

IMPORTANT: Customer and installer, be sure to identify the pump and motor manufacturer for installation and maintenance purposes. Information is attached on the pumping unit.

CAUTION: Have a certified electrician install 230v single phase to motor. Use proper size wire for 30 Amp circuit. (See diagrams)

IMPORTANT: Use separate circuit for each unit. Western recommends a 220v 30 Amp twist lock within reach of the power unit for quick disconnect.

IMPORTANT: Protect each circuit with 30 Amp time delay fuse or 30 Amp circuit breaker.

CAUTION: Motor cannot run on 50Hz.

NOTES

1. Unit is not suitable in unusual conditions. Contact factory for moisture resistant unit.
2. Wiring must comply with all state and local codes.
3. Power unit drawings may vary by manufacturer.

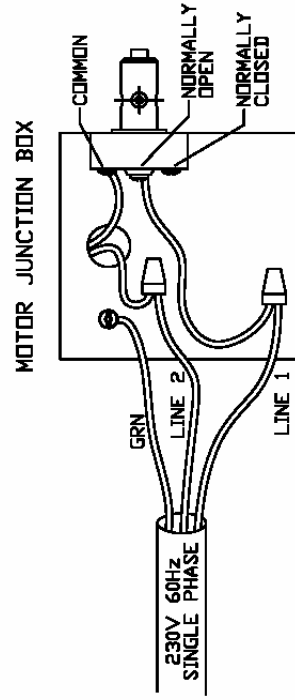
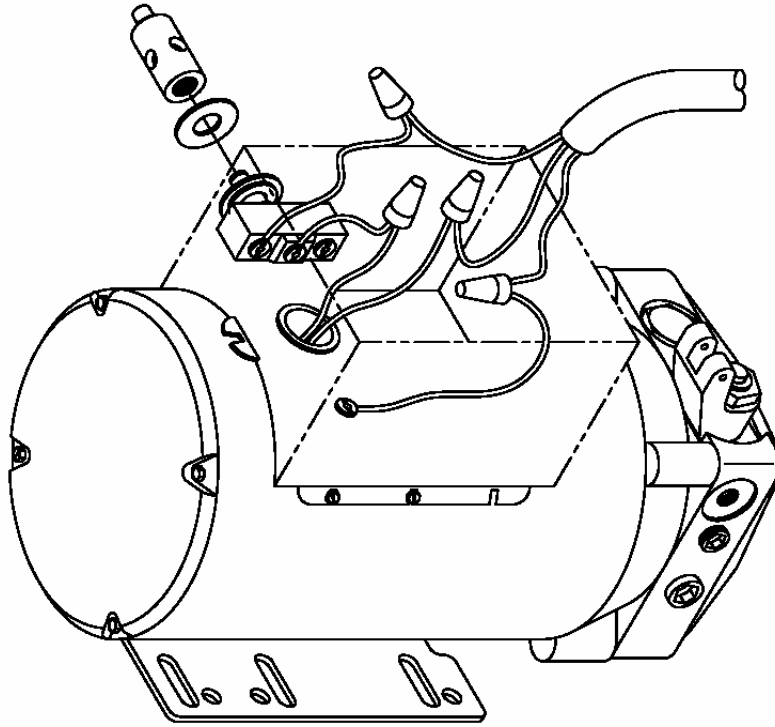

Figure 3 - Pump and Wiring Diagram

EXCAVATION:

1. Dig a hole to accommodate cylinder, a minimum of 18" x 18" x 101" deep (See Figure 2)
2. Dig a 9" trench from proposed position of the cylinder hose box forward to the pump location. This will accommodate the 1-1/2" PVC pipe chase for hydraulic hose.
3. Using tripod or 4 x 4 beams and threaded rod, suspend cylinder in a perfectly vertical position with the non-rotator 90° to the left of forward drive through direction. Leave flange ring approximately 1/8" above finished floor line.
4. Check plumbness with spirit level across piston top in two directions. Adjust if necessary.
5. Shovel wet mix concrete evenly around to a level at least 6" above bottom of cylinder. (See Figure 2).
6. Backfill with clean dry fill dirt to approximately 7" from level.
7. Assemble one piece (cut to the correct length) of 1-1/2" PVC pipe to hose box female fitting provided. Use 90° elbow just shy of wall where pump is to be mounted. Finish off by leaving pvc approximately 2" above finished floor level.
8. Cover PVC with fine dirt or sand.
9. Pour and finish concrete making sure cylinder is not stained with concrete. Remember, it is best to slightly taper concrete up at cylinder to prevent any standing water around cylinder flange.
10. After allowing 48 hours for concrete to cure, attach superstructure, leaving nuts loose until non-rotator leg is attached and lift is raised and lowered for self alignment.
11. Drill and mount pump at desired height location with the 4: 1/4" x 4" anchors provided.
12. Have a certified electrician wire your pump to the pump motor electrical diagram provided. (See Figure 3).
13. Attach hydraulic hose provided to the 900 pump fitting and reed hose through PVC pipe chase to side box. Remove box lid and attach hose at box (use of teflon tape at all fittings is recommended). Leave box top off until lines are observed for leaking.
14. Fill pumping unit with premium quality hydraulic oil with a ISO rating of #32. (10 wt. hydraulic oil).

15. Raise lift approximately 12" high and bleed lifting cylinder at small hole in superstructure center with 7/16" socket wrench until all air is removed from cylinders. Tighten plug. CAUTION-DO NOT let lifting cylinders rotate more than 30° in any direction as this can cause hose damage at base of cylinder.
16. Check oil level and fill if needed.
17. Cycle lift for proper aligning of bolts and then tighten superstructure bolts. Torque 7/8" bolster bolts to 450 foot pounds.
18. Check retainer allen head bolts for tightness.
19. Check all hose fittings at pump and box. If leaking, redo with proper thread sealer.
20. Apply silicone seal to hose box lid resting lip and secure lid with screws.
21. Spray light silicone lubricant to black piston surface and spread evenly with clean cloth for surface lubrication.(Use clean cloth as shop rags sometimes have debris which could scratch surface)
22. Locate wheel spotting plate to location desired for vehicles to be lifted. (See Figure 1 for a general shop bay layout.)

FINAL CHECK OF ASSEMBLED LIFT:

1. Check for air and hydraulic leaks. _____
2. Ensure all safety lock mechanism are working correctly. _____
3. Check all fasteners, tighten if necessary. _____
4. Operate lift to full stroke then lower to ground while checking for proper functionality. _____
5. Ensure Customer Care Kit is complete and given to operator. _____
 - a. Operation Manual _____
 - b. ANSI / ALI Lift It Right Manual _____
 - c. ANSI / ALI Safety Tip Card _____
 - d. ANSI / ALI ALIS Safety Requirements for Installation and service of Automotive Lifts _____
 - e. ANSI / ALI Quick Reference Guide _____
6. Train end user on operation of the lift. _____

OPERATING INSTRUCTIONS

LIFTING:

1. Push in on “pump electrical switch” and raise lift until adapters contact vehicle.
2. Check to make certain all adapters are making full and proper contact.
3. Raise approximately 18” and check stability by rocking vehicle front to rear.
4. When raising the lift, the lock will engage at full stroke. Lower lift onto lock.

LOWERING:

1. Make sure area under vehicle is clear of obstacles.
2. Raise lift slightly and disengage locking device.
3. Lower lift until lift superstructure makes full contact with floor.
4. Rotate arms to provide tire clearance.
5. Make certain adapters are in the flat position before removing vehicle.

REGULAR MAINTENANCE

1. Inspect all superstructure fasteners. Tighten if necessary.
2. Grease swivel arm rub bars.
3. Inspect arms for overload drooping from stretched or loosened arm bolts. Have loose bolts tightened and stretched bolts replaced.
4. Inspect the “3” position adapters for damage and replace if necessary.
5. Use a spray can of silicon lubricant on piston surface. NOTE: Clean and wipe down pistons with a clean dry cloth before applying the silicon lubricant

TROUBLE SHOOTING GUIDE

Problem

Possible cause and solution.

- 1) Pump motor does not run
 - A. Breaker tripped or fuse blown. Check breaker and incoming power.
 - B. Motor thermal overload tripped. Wait for overload to cool.
 - C. Check thermal overload in starter box (3 phase only. Rush “Reset”
 - D. Faulty wiring connections. Check wiring diagram

- 2) Motor runs but the lift will not raise or hold a load.
 - A. A foreign object is lodged under check valve, located behind the lowering handle. As you are running the pumping unit, push in and out several times on the lowering valve handle. This should release any foreign objects trapped in the pump
 - B. Remove check valve. Clean the ball and seat and replace.
 - C. Oil level low. Check reservoir. With lift in the “down” position, pump reservoir should be full.

- 3) Motor runs but the lift picks up partial load only
 - A. Lift is overloaded. Check lift capacity and weight of vehicle.
 - B. Relief valve setting is too low. Remove hex head plug in the center of the pump and adjust pressure setting valve. Turn clockwise about 1/4 turn at a time until the lift picks up the load.

- 4) Oil blows out breather
 - A. Oil reservoir overfilled.
 - B. Lift lowered too quickly while under heavy load.

- 5) Lift makes groaning sound when raised
 - A. Bleed cylinder manually. Trapped air can cause groaning noise when raising or lowering lift.

PARTS LIST

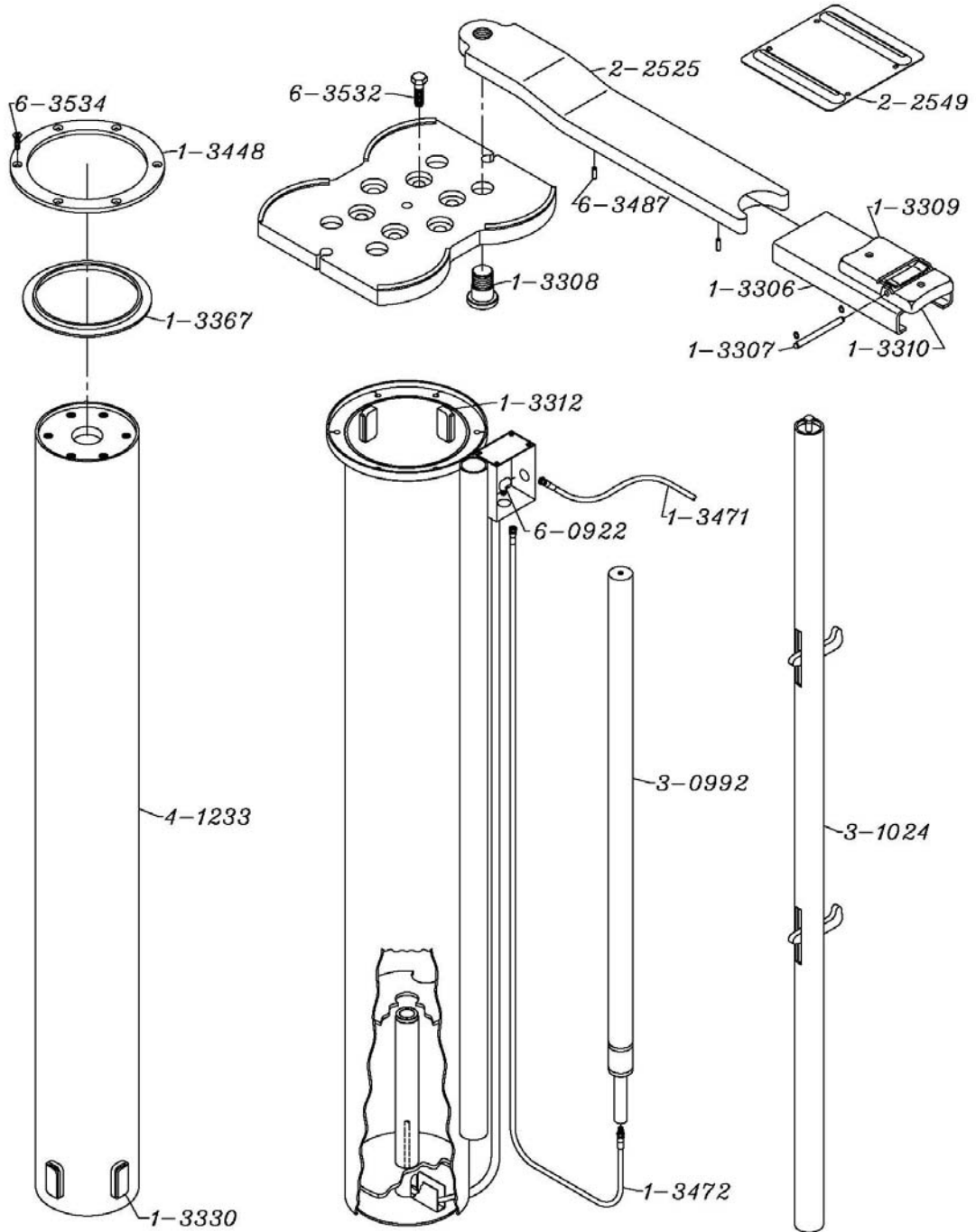

Part No.	Qty.	Description
6-3532	6	Bolster Bolt
1-3306	4	Sleeve and Adapter
1-3309	4	High Side Flip Up
1-3310	4	Low Side Flip Up
1-3307	4	Wing Pin and Clips
2-2549	1	Wheel Spot Plate
2-2525	4	Swing Arm
1-3308	4	Arm Bolt
1-3330	4	Lower Bearing Block
1-3312	4	Upper Bearing Block
1-3471	1	18' Hyd. Pump Hose
6-3487	8	3/8" x 1" Roll Pin
4-1233	1	Ø10-5/8" Piston
1-3367	1	Rubber Wiper
1-3448	1	Flange Ring
3-0992	1	Hydraulic Cylinder
1-3472	1	10' Cylinder Hose
3-1024	1	Locking Leg
6-3532	6	7/8" Superstructure Bolt
6-0922	1	90° Fitting
6-3490	1	Power Pack