

ATOMIC
ARCHITECTURAL
SHEET METAL,
INC.

ASM Panel Brochure

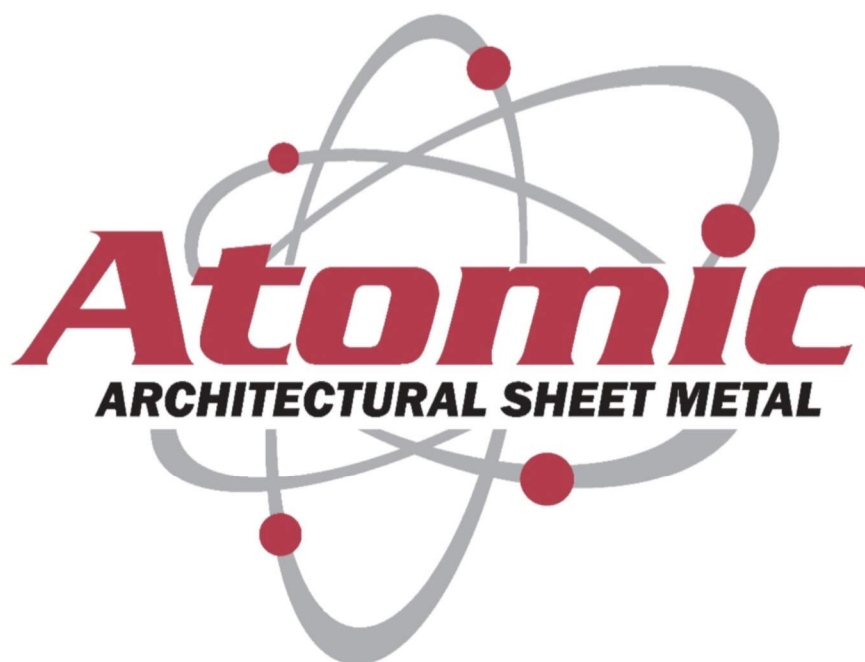

3207 Labore Road
Vadnais Heights, MN 55110
Phone: 651-646-1706
Fax: 651-646-1684
atomic@atomicsheetmetal.com
www.atomicsheetmetal.com

ACM- ALUMINUM COMPOSITE PANELS

1. ASM EVO D-J Panel (Dry-Joint)
2. ASM W-S Panel (Wet-Sealed)
3. ASM Column Cover

METAL ROOFING PANELS

4. ASM M-L Panel (Mechanical Lock)
5. ASM N-S Panel (Nail Strip)
6. ASM S-L Panel (Snap Lock)
7. ASM S-S Panel (Standing Seam)

METAL WALL & SOFFIT PANELS

8. ASM F-L-W Panel (Flat Lock Wall)
9. ASM F-S-F Panel (Flat Seam Flush)
10. ASM F-S Panel (Flush Seam)
11. ASM Reveal Panel
12. ASM E-S Louver System

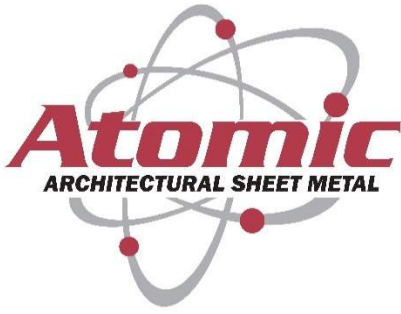

3207 Labore Road | Vadnais Heights, MN 55110
Phone: 651-646-1706 | Fax: 651-646-1684
email: atomic@atomicsheetmetal.com
www.atomicsheetmetal.com

ASM EVO D-J PANEL

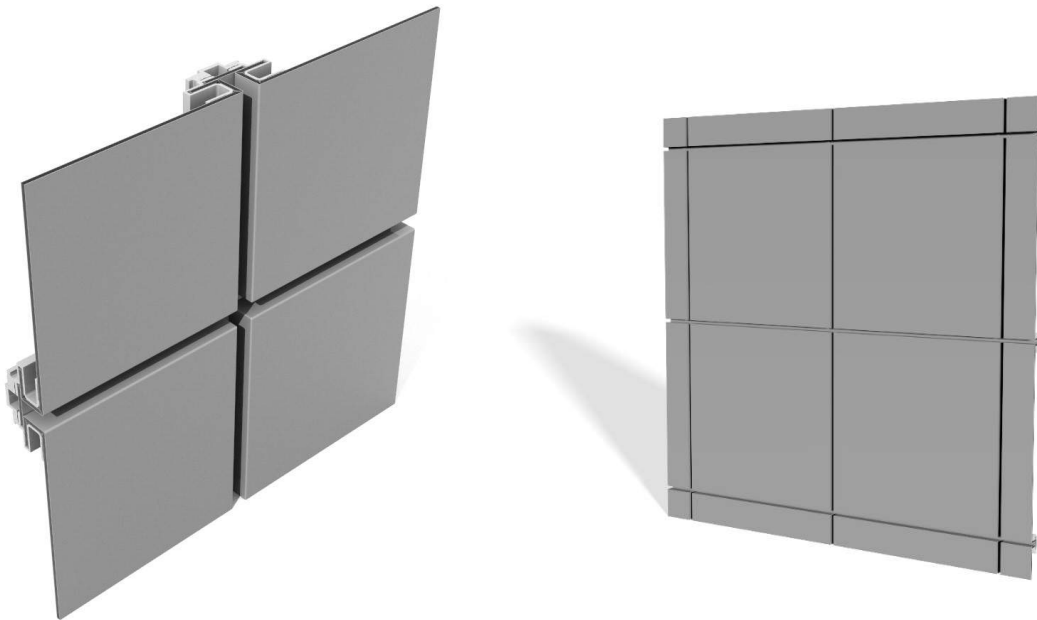

The ASM EVO D-J Composite Panel features:

- Rivetless Dry-Joint rainscreen system
- 4mm aluminum composite material
- 9/16" Panel Joint
- 1-3/4" panel depth (2-1/2" total with hat channel) Hat channel required at certain conditions
- Fabricated on a CNC machine using the route and returned method
- Radiused and vented options
- Panel widths can vary and are available up to 5' max
- Panel lengths can vary and are available up to 16' max
- We work with the top composite material manufacturers for a wide range of color and finish options
- Rainscreen, Air/Water/Wind Performance Tested. All testing info available upon request.

Please contact us for more information regarding pricing, installation, detailing, testing or for any questions you may have.
11/19/2021

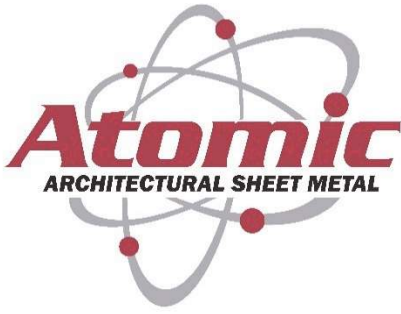

3207 Labore Road | Vadnais Heights, MN 55110
Phone: 651-646-1706 | Fax: 651-646-1684
email: atomic@atomicsheetmetal.com
www.atomicsheetmetal.com

ASM W-S PANEL

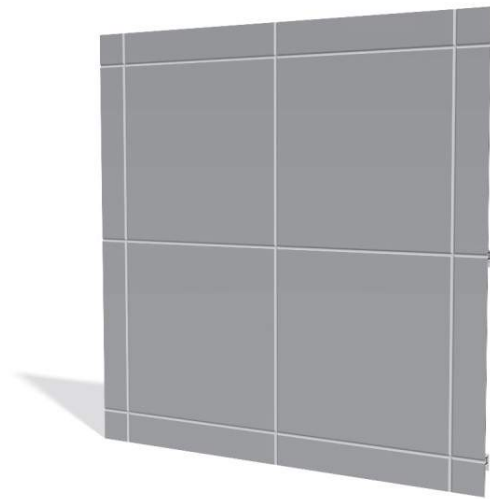

The ASM W-S (Wet-Seal) Composite Panel features:

- Weather-sealed panel joints utilizing high quality silicone sealant with backer rod
- 4mm aluminum composite material (Most common)
- 1/2" panel joints typical
- 1-1/2" or 2" panel depth (+3/4" with hat channel) Hat channel required at certain conditions
- Fabricated on a CNC machine using the route and returned method
- Radiused and vented options
- Panel widths can vary and are available up to 5' max
- Panel lengths can vary and are available up to 16' max
- We work with the top composite material manufacturers for a wide range of color and finish options

Please contact us for more information regarding pricing, installation, detailing, or for any questions you may have.
4/6/2021

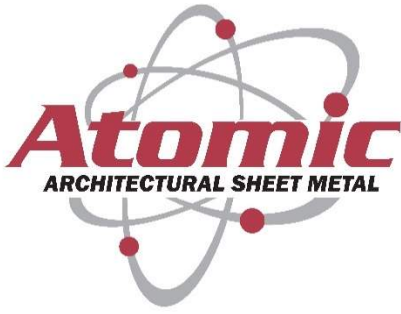

3207 Labore Road | Vadnais Heights, MN 55110
Phone: 651-646-1706 | Fax: 651-646-1684
email: atomic@atomicsheetmetal.com
www.atomicsheetmetal.com

ASM Column Cover

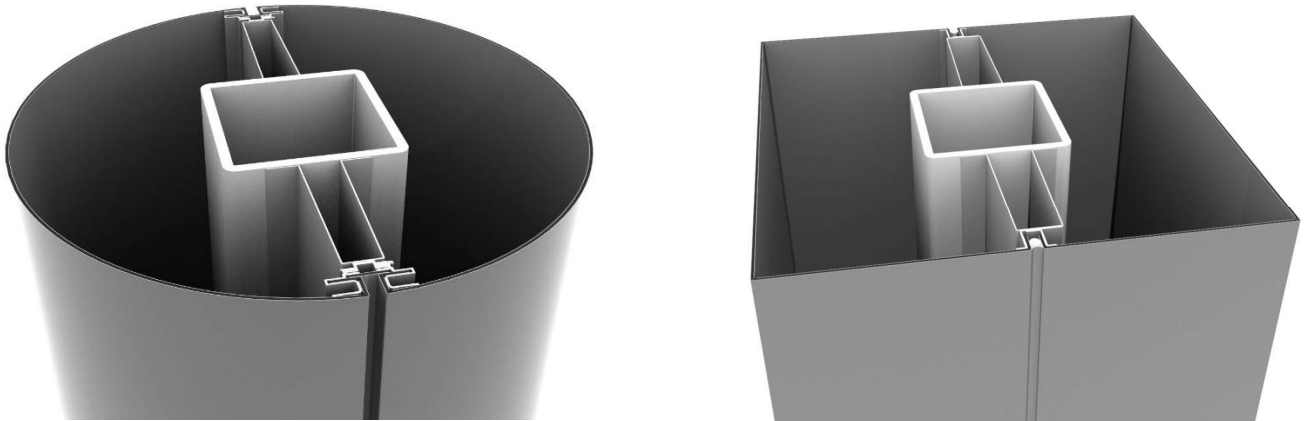

The ASM Column Cover features:

- 4mm aluminum composite material (Most common)
- Various profiles (Round, Square, Rectangle, Full Column or Half)
- Fabricated on a CNC machine using the route and returned method
- EVO Dry-Joint, Wet Sealed, or Hairline Joint options
- Available in various Finishes (Colors, Woodgrains, Stone, Aluminum, & Stainless Steel)
- We work with the top composite material manufacturers for a wide range of color and finish options

Please contact us for more information regarding pricing, installation, detailing, or for any questions you may have.
11/19/2021

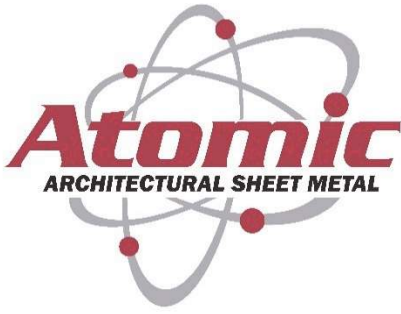

3207 Labore Road | Vadnais Heights, MN 55110
Phone: 651-646-1706 | Fax: 651-646-1684
email: atomic@atomicsheetmetal.com
www.atomicsheetmetal.com

ASM M-L PANEL

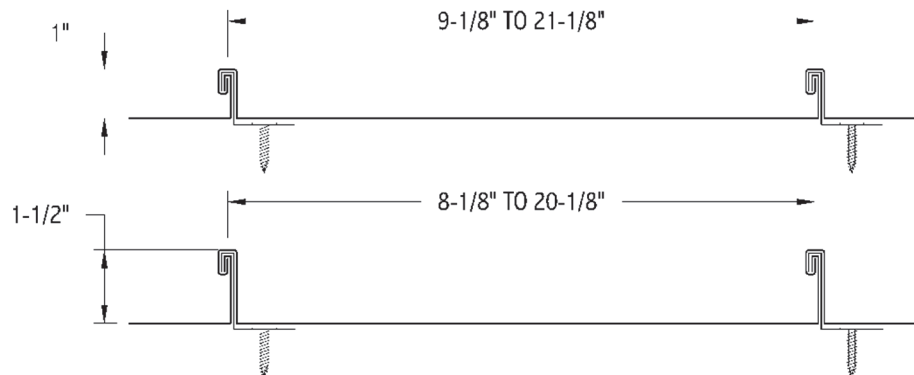

The ASM M-L (Mechanical Lock) Panel features:

- 1" or 1-1/2" tall ribs
- Various widths to choose from (contact us for best o.c.)
- Smooth or with stiffening ribs
- Can be curved for radiused roofs
- Available in various materials (Steel, Aluminum, Copper, Zinc)
- Available in various gauges (Steel-24 & 22ga. Alum.-.032)
- We work with the top sheet metal manufacturers for a wide range of material, color, and finish options

Please contact us for more information regarding pricing, installation, detailing, or for any questions you may have.
4/6/2021

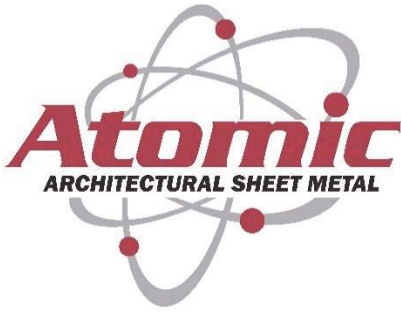

3207 Labore Road | Vadnais Heights, MN 55110
Phone: 651-646-1706 | Fax: 651-646-1684
email: atomic@atomicsheetmetal.com
www.atomicsheetmetal.com

ASM N-S PANEL

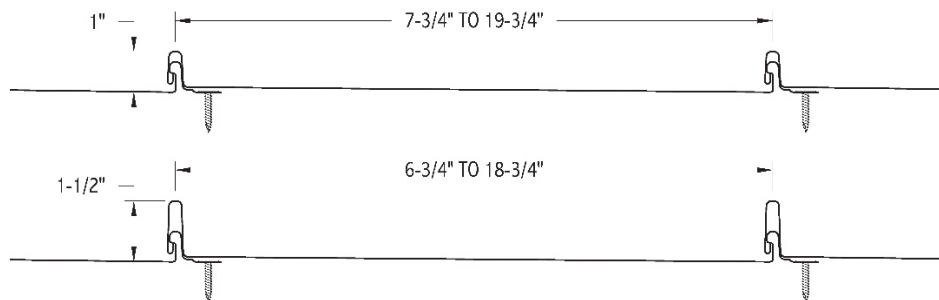

The ASM N-S (Nail-Strip) Panel features:

- 1" or 1-1/2" tall ribs
- Various widths to choose from (contact us for best o.c.)
- Smooth or with stiffening ribs
- Available in various materials (Steel, Aluminum, Copper, Zinc)
- Available in various gauges (Steel-24 & 22ga. Alum.-.032)
- We work with the top sheet metal manufacturers for a wide range of material, color, and finish options

Please contact us for more information regarding pricing, installation, detailing, or for any questions you may have.
4/6/2021



3207 Labore Road | Vadnais Heights, MN 55110
Phone: 651-646-1706 | Fax: 651-646-1684
email: atomic@atomicsheetmetal.com
www.atomicsheetmetal.com

ASM S-L PANEL

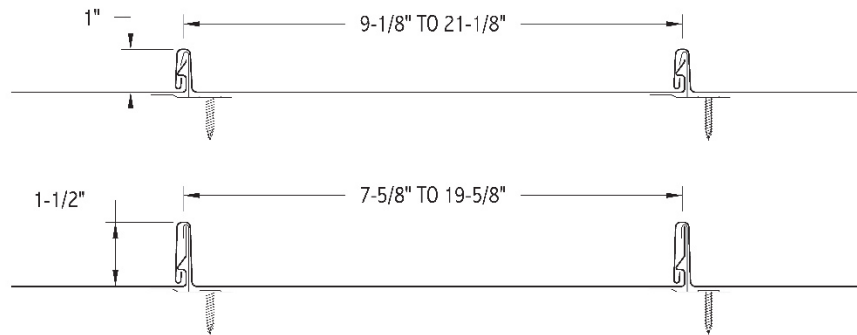

The ASM S-L (Snap-Lock) Panel features:

- 1" or 1-1/2" tall ribs
- Various widths to choose from (contact us for best o.c.)
- Smooth or with stiffening ribs
- Available in various materials (Steel, Aluminum, Copper, Zinc)
- Available in various gauges (Steel-24 & 22ga. Alum.-.032)
- We work with the top sheet metal manufacturers for a wide range of material, color, and finish options

Please contact us for more information regarding pricing, installation, detailing, or for any questions you may have.
4/6/2021

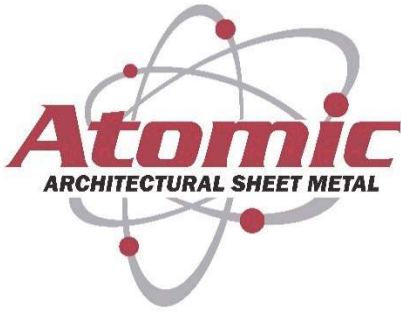

3207 Labore Road | Vadnais Heights, MN 55110
Phone: 651-646-1706 | Fax: 651-646-1684
email: atomic@atomicsheetmetal.com
www.atomicsheetmetal.com

ASM S-S PANEL

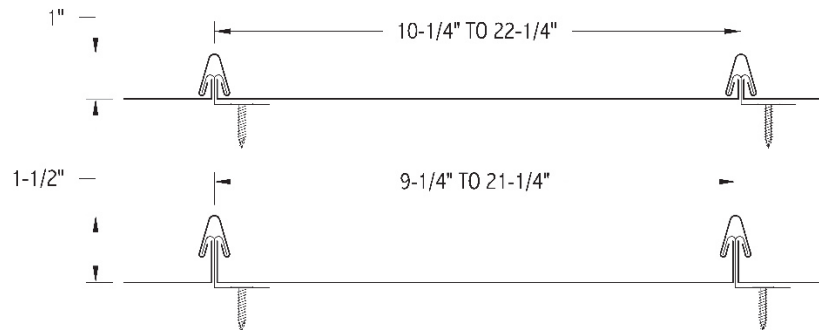

The ASM S-S (Standing Seam) Panel features:

- 1" or 1-1/2" tall ribs
- Various widths to choose from (contact us for best o.c.)
- Smooth or with stiffening ribs
- Can be curved for radiused roofs
- Available in various materials (Steel, Aluminum, Copper, Zinc)
- Available in various gauges (Steel-24 & 22ga. Alum.-.032)
- We work with the top sheet metal manufacturers for a wide range of material, color, and finish options

Please contact us for more information regarding pricing, installation, detailing, or for any questions you may have.
4/6/2021



3207 Labore Road | Vadnais Heights, MN 55110
Phone: 651-646-1706 | Fax: 651-646-1684
email: atomic@atomicsheetmetal.com
www.atomicsheetmetal.com

ASM F-L-W PANEL

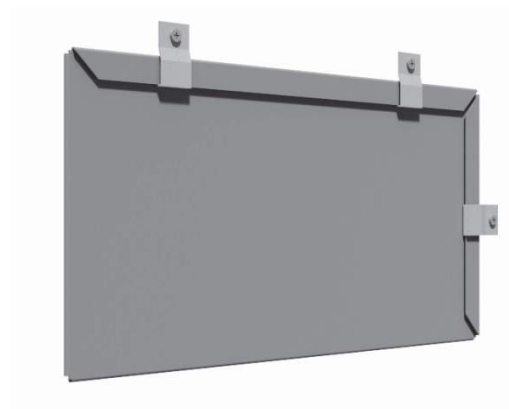

The ASM F-L-W (Flat Lock Wall) Panel features:

- Available in various heights & widths to create a square, rectangle, or diamond pattern (contact us for best o.c.)
- Interlocking system with concealed fasteners
- Available in various materials (Steel, Aluminum, Copper, Zinc)
- Available in various gauges (Steel-24 & 22ga. Alum.-.032)
- We work with the top sheet metal manufacturers for a wide range of material, color, and finish options

Please contact us for more information regarding pricing, installation, detailing, or for any questions you may have.
4/6/2021



3207 Labore Road | Vadnais Heights, MN 55110
Phone: 651-646-1706 | Fax: 651-646-1684
email: atomic@atomicsheetmetal.com
www.atomicsheetmetal.com

ASM F-S-F PANEL

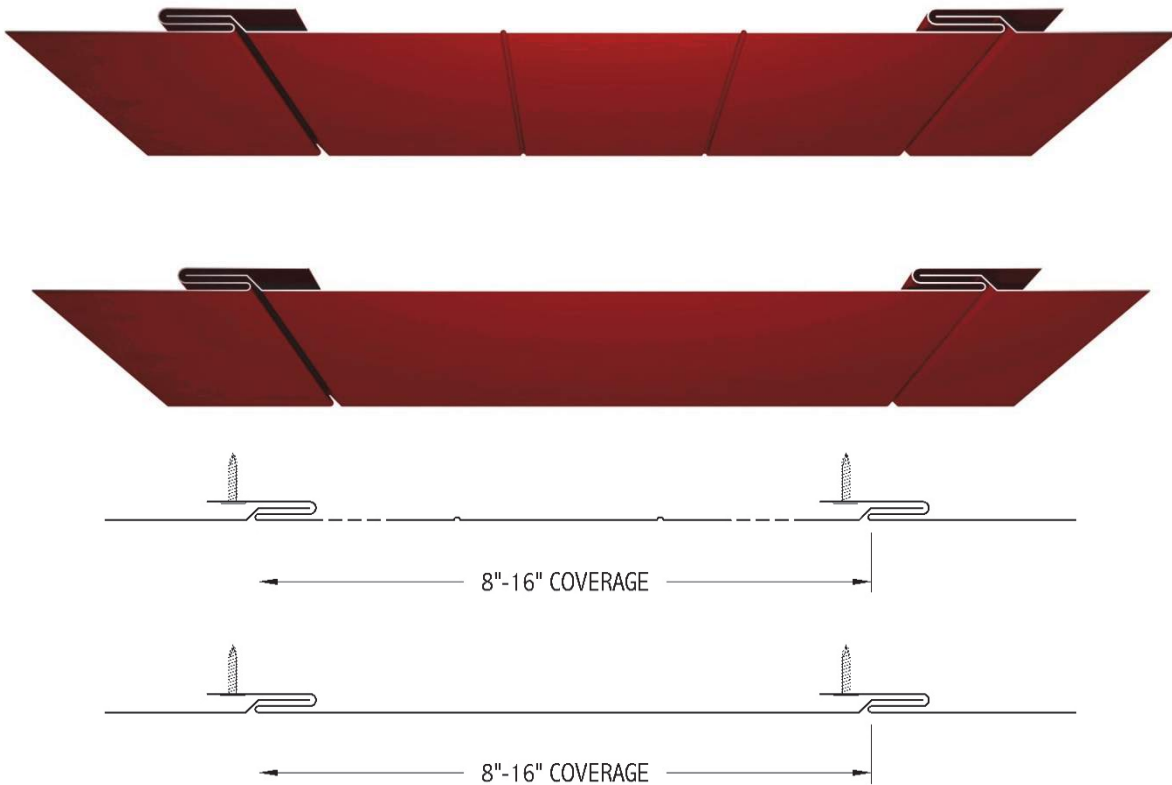

The ASM F-S-F (Flat-Seam Flush) Panel features:

- Wall and soffit application
- A slim 3/8" deep
- 8"-16" coverage and a 12' max length (contact us for best o.c.)
- Smooth, vented, with stiffening ribs, or a combination
- Concealed fasteners
- Available in various materials (Steel, Aluminum, Copper, Zinc)
- Available in various gauges (Steel-24 & 22ga. Alum.-.032)
- We work with the top sheet metal manufacturers for a wide range of material, color, and finish options

Please contact us for more information regarding pricing, installation, detailing, or for any questions you may have.
4/6/2021

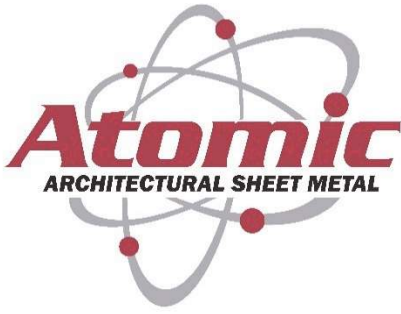

3207 Labore Road | Vadnais Heights, MN 55110
 Phone: 651-646-1706 | Fax: 651-646-1684
 email: atomic@atomicsheetmetal.com
www.atomicsheetmetal.com

ASM F-S PANEL



Popular Profiles

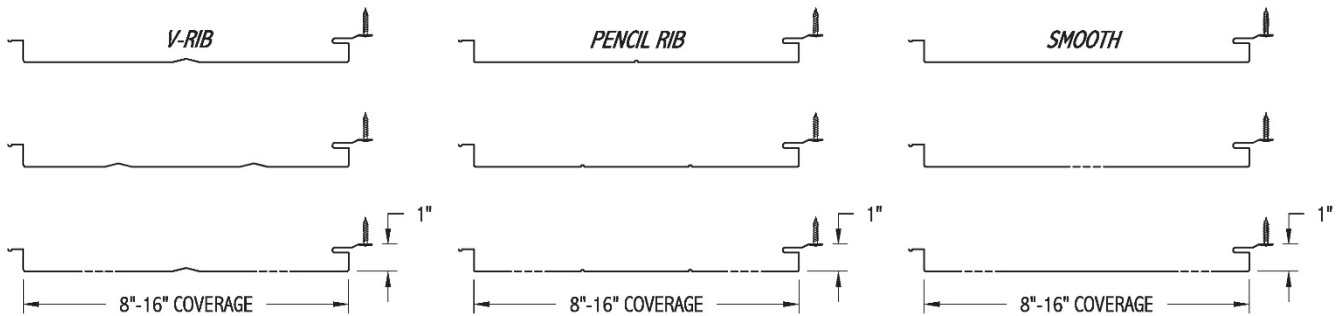

The ASM F-S (Flush-Seam) Panel features:

- Wall and soffit application
- Can be used over open framing or solid substrate (certain conditions may require additional furring)
- 8"-16" coverage (contact us for best o.c.)
- Smooth, vented, with stiffening ribs, or a combination (Venting offered in 24 ga. steel only)
- Concealed fasteners
- Available in various materials (Steel, Aluminum, Copper, Zinc)
- Available in various gauges (Steel-24 & 22 ga. Alum.-.032)
- We work with the top sheet metal manufacturers for a wide range of material, color, and finish options

Please contact us for more information regarding pricing, installation, detailing, or for any questions you may have.
 4/6/2021



3207 Labore Road | Vadnais Heights, MN 55110
Phone: 651-646-1706 | Fax: 651-646-1684
email: atomic@atomicsheetmetal.com
www.atomicsheetmetal.com

ASM REVEAL PANEL

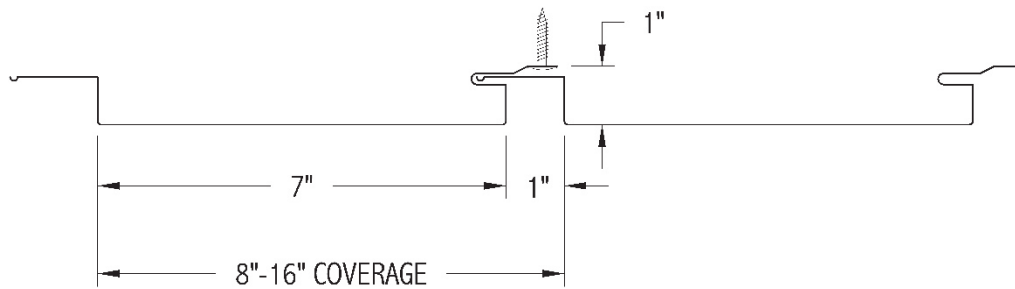

The ASM Reveal Panel features:

- Wall and soffit application
- Can be used over open framing or solid substrate (certain conditions may require additional furring)
- 1" reveal
- 8"-16" coverage (contact us for best o.c.)
- Smooth, vented, with stiffening ribs, or a combination
- Concealed fasteners
- Available in various materials (Steel, Aluminum, Copper, Zinc)
- Available in various gauges (Steel-24 & 22ga. Alum.-.032)
- We work with the top sheet metal manufacturers for a wide range of material, color, and finish options

Please contact us for more information regarding pricing, installation, detailing, or for any questions you may have.
4/6/2021

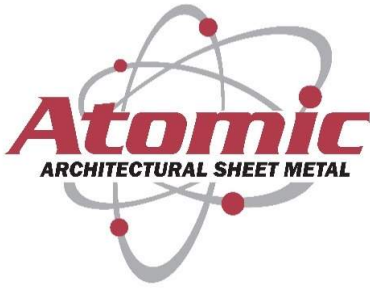

3207 Labore Road | Vadnais Heights, MN 55110
Phone: 651-646-1706 | Fax: 651-646-1684
email: atomic@atomicsheetmetal.com
www.atomicsheetmetal.com

ASM E-S Louver System

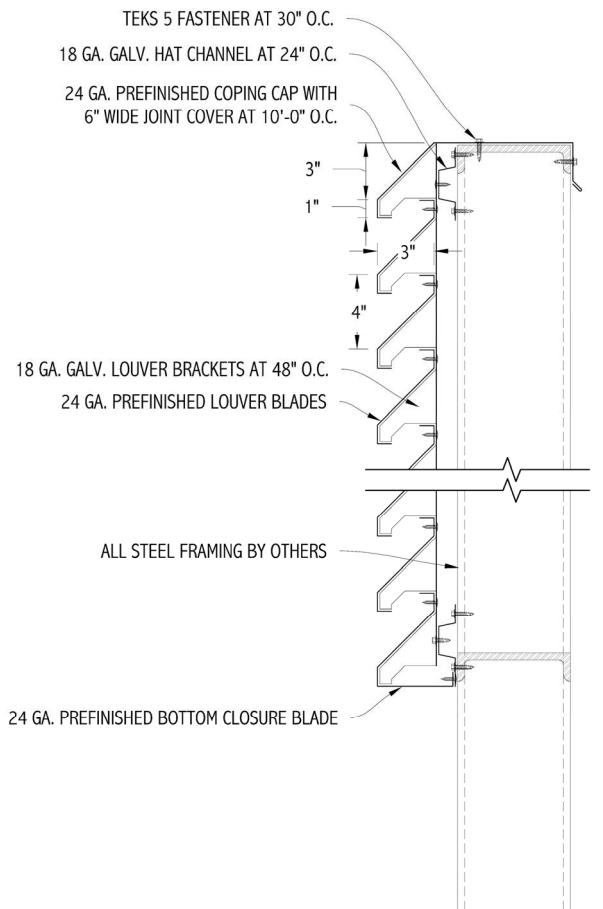

The ASM E-S Louver System features:

- Designed to hide unwanted views of mechanical equip., HVAC equip., trash enclosures, and other applications
- Allows air flow
- Available in various materials & gauges (Steel, Aluminum)
- We work with the top sheet metal manufacturers for a wide range of material, color, and finish options

Please contact us for more information regarding pricing, installation, detailing, or for any questions you may have.
11/18/2021

ATOMIC
ARCHITECTURAL
SHEET METAL,
INC.

Installing Metal for over
30 years

