

Deep Well Pump Control Valve

INSTRUCTIONS

Installation – Operation – Inspection – Maintenance

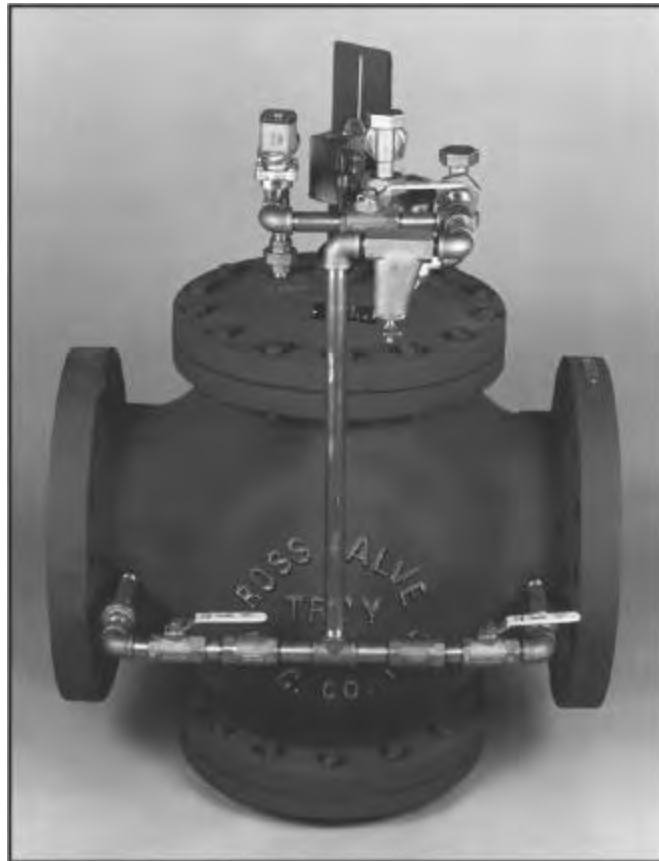

4" – 16" ROSS MODEL – 45WR Serial #L _____
DEEP WELL PUMP CONTROL VALVE

GLOBE FLAT SEAT STYLE

ROSS VALVE Mfg. Co., Inc.

PO BOX 595, TROY, NY 12181 – PHONE 518/274-0961 – FAX 518/274-0210

INSTALLATION / START-UP (ROSS PISTON VALVE – GLOBE OR ANGLE STYLE)

Shipment:

Prior to shipment, each valve is thoroughly tested and pre-adjusted at the factory to the expected field conditions. Any visible damage to the crate or packaging should be immediately brought to the attention of the shipping company and documented with photographs.

Depending upon the valve size, external controls may be attached or in a separate box. The inlet of the main valve is identified with a metal tag. When controls are shipped separately, connections are tagged.

Storage:

If it is necessary to store the valve before installation, it should be protected from the elements. Inside storage is recommended. If this is not possible, the valve should be protected from dirt, heat, freezing, and direct sunlight.

Installation:

1. Carefully remove all shipping materials and check the valve for any other foreign objects.
2. If possible, flush the line before inserting the valve.
3. The valve is tagged with a model and serial number. It is recommended that the serial number be noted in your records as this will be requested by the factory when any technical support or parts replacement is required. **Valve serial number: L_____.**
4. Place the valve in line with the flange marked "INLET" facing the high pressure or supply line.
CAUTION: Do not obstruct the vent hole in the center of the bottom cap (#16 for Globe Body valves) or in the differential cylinder bracket (#27 for Angle Body valves). Allow enough clearance above the valve for removal of the stem assembly.
5. If external piping and controls are not attached to the valve when shipped, connect couplings identified with tags that are numbered. The arrow on the pilot valve body points in the direction of flow through the pilot valve. Flow is always away from the top cap of the main valve. The indicator rod (#20) shows the position of the main stem.
6. Attach gauge cocks to the back side of the valve.
7. Complete any necessary wiring on solenoid valves (if applicable).

Start-Up:

1. Close the isolation valves (#18) in the control piping.
2. Open the main line gate valve (if installed) on the discharge/downstream side of the valve.
3. *Slowly* open the main line gate valve (if installed) on the inlet/upstream side of the valve.
4. Open the isolation valves (#18) in the control piping.
5. Loosening the union of the control piping on the top cap side of the speed control valve will help bleed air and give a positive indication when the operating chamber is full. It may be necessary to apply pressure to the valve indicator rod (if provided) with a wrench handle or block of wood until the valve operating chamber is pressurized.
6. No lubrication or adjustment to the valve is required or recommended. The valve has been thoroughly tested at the factory and set to the expected field conditions.

DEEP WELL PUMP VALVE

Purpose: Blow off air or turbidity

Model Number: 45WR

Sizes: 2" - 48"

Type: Nonthrottling System

Primarily Controlled By: Electricity

Located: In tee connection

Purpose: To blow off air or sand particles agitated (turbidity) by the pump starting

Inlet Pressure: Maximum: 300 psi

Inlet Pressure: Minimum: 5 psi

Construction: Body: " - 36" - Cast iron (semi-steel) with bronze trim
40" - 48" - Ductile iron, with bronze/stainless steel trim

External Spring Assists:

To open or close the valve

Control Devices:

Strainer: Model 5F-2

Valves:

Needle: (Closing Control)

Needle: (Opening Control)

Pilot: Solenoid: 3 Way

Other System Components:

Limit Switch: Wired to normally closed contact

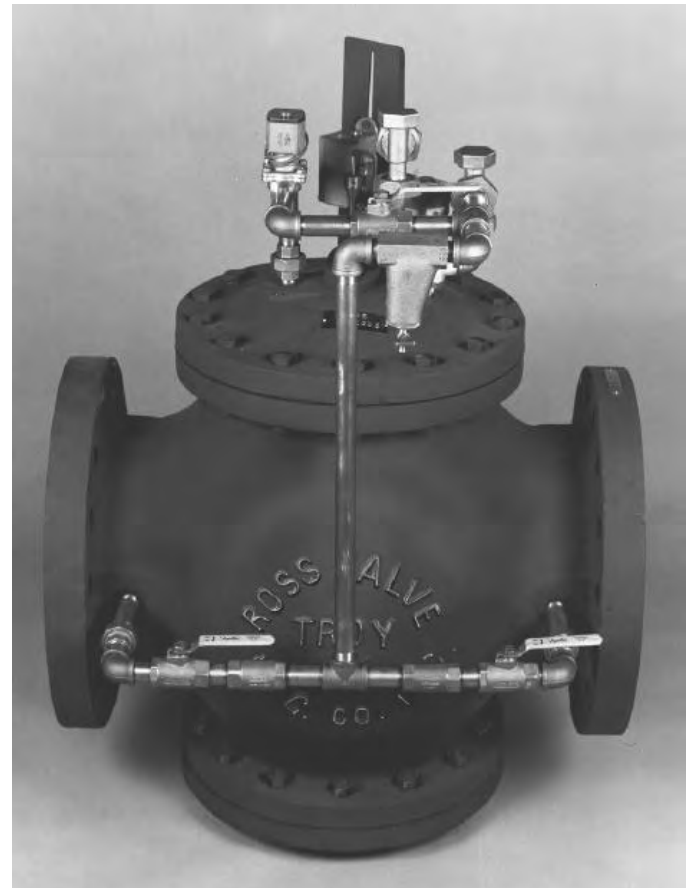

Basic Application

Insure that only water, not debris or air, flows through the system.

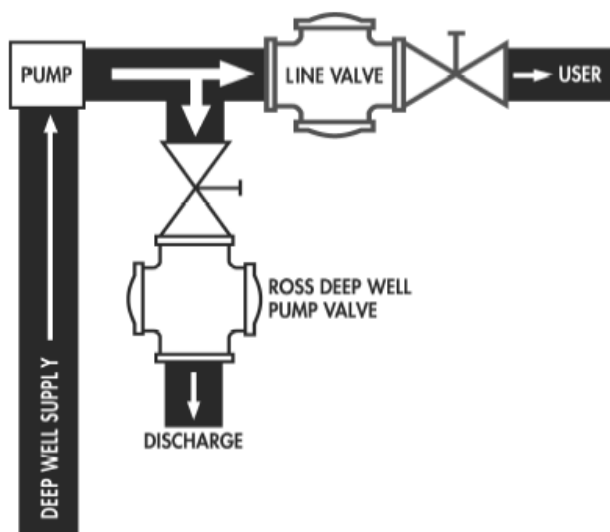

If: Pump is not running

Ross Main Valve will: Remain open.

When: Pump starts

Ross Main Valve will: Close slowly after discharging initial air and water with possible debris.

When the valve closes water can flow smoothly through the main line.

When: Pump stops

Ross Main Valve will: All ready be 95% open to minimize possible surges.

DEEP WELL PUMP VALVE

Operation

Model Number: 45WR

Control Unit

A carefully balanced system along an external piping circuit monitors the water flow in and out of the operating chamber and, consequently, the piston open/closed position relative to the pump stopping and starting. It includes:

- A. External Piping with several basic segments which run from the:
1. Inlet side of the main valve to a pipe leading into the operating chamber.
 2. Outlet side of the main valve to a pipe leading out of the operating chamber.
 3. Inlet/outlet external pipes into the operating chamber.
- B. Normal Solenoid pilot valve - Three openings and two ports control pressure in the operating chamber:
- 1 Opening - to the operating chamber.
 - 1 Opening - to the line (controlled by 1 port).
 - 1 Opening - to waste (controlled by 1 port).
- C. Needle Valves - Two valves control maximum flow:
- 1 Needle - into the operating chamber.
 - 1 Needle - out of the operating chamber.
- D. Limit Switch - Switches on and off by movement of a valve indicator.

Operation

Because the valve is full open when the pump starts and then slowly closes, it effectively discharges unwanted air and sand particles from the system before water flows through the main line.

In addition the valve insures a smooth stopping and starting flow in the system by closing slowly after the pump starts and being 95% open before the pump stops.

- A. A deep well pump valve is normally open. In order to close it, the
1. Control switch contacts close, energizing the relay coil R.
 2. Two R contacts close together energizing the:
 - a. Normal solenoid coil S_3 .
 - b. Pump motor starter coil M.
 3. Pump starts
 4. Initial air, water which might contain sand particles gets discharged from the system through the open valve located in a tee.
 5. When the pump develops enough line pressure, the valve slowly closes.
 6. As the valve closes, limit switch, LS, closes and parallels the R contact to be in series with the pump motor starter M.

- B. In order to open the deep well valve, the
1. Control switch contacts open, de-energizing the relay coil R.
 2. Two R contacts open and de-energize only the normal solenoid coil S_3 .
 3. Deep well pump valve begins to open.
 4. Limit switch, whose contacts are still closed, continues to energize the pump motor starter coil M.
 5. Pump continues running.
 6. Main line valve reaches 95% open causing the limit switch contacts to open and de-energizing the pump motor starter M.
 7. Pump stops.

Simple example incorporating Second 2 Way Solenoid (customized) feature.

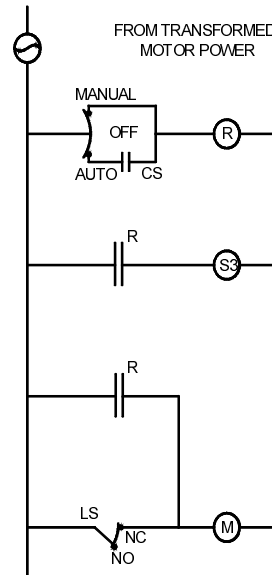

- CS = Control Switch
M = Motor Starter Relay
R = Double Pole Normally Open Relay
LS = Limit Switch (Shown in Valve Closed Position)
 S_3 = Normal Solenoid Coil

Note

Make sure the main pump breaker is open before any work is done on the valve.

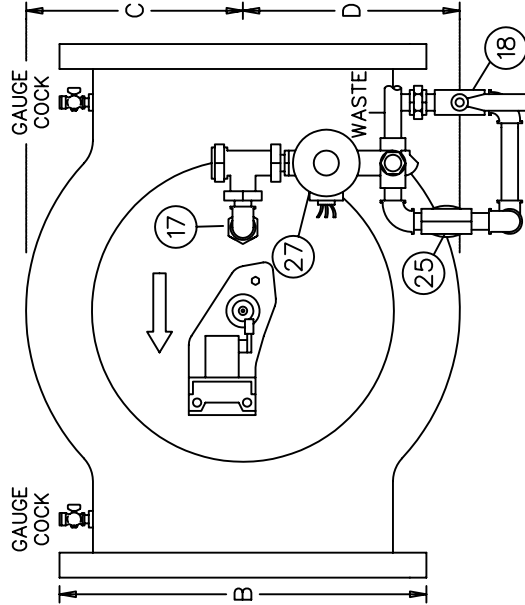
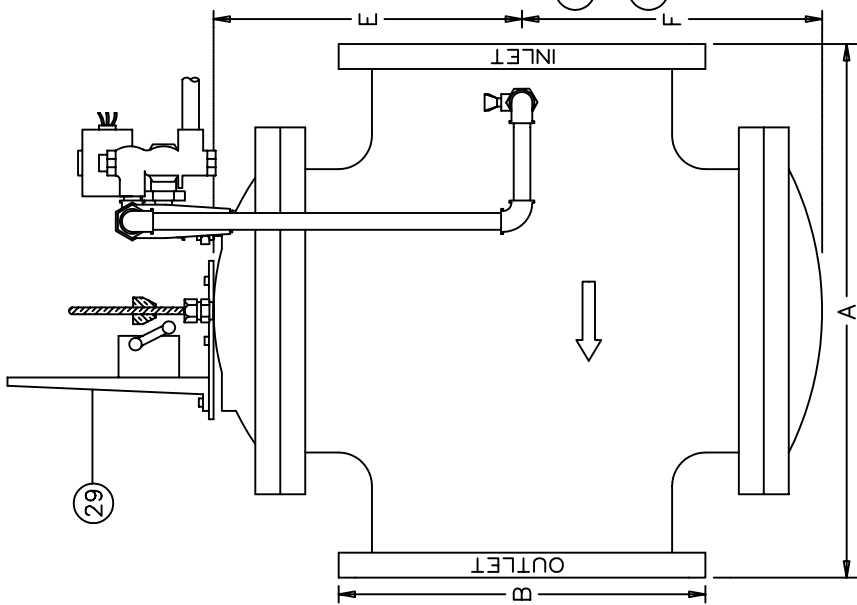
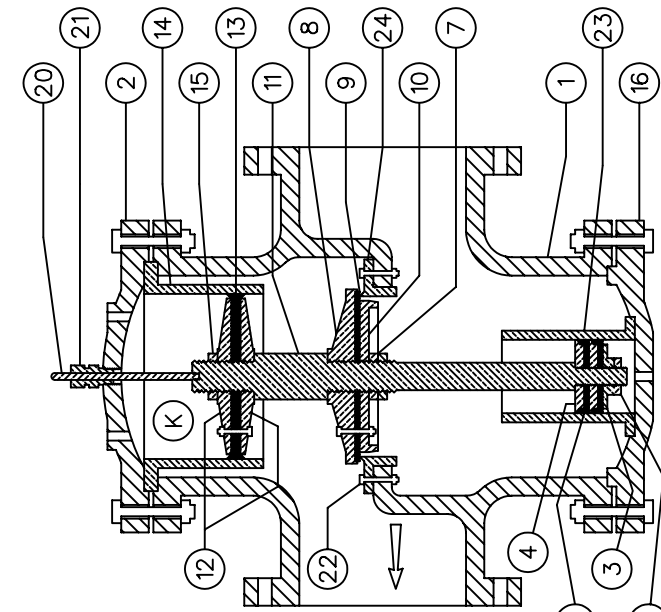

PART	DESCRIPTION	QTY.	MATERIAL
1	VALVE SHELL	1	CAST IRON
2	TOP CAP	1	CAST IRON
3	BOTTOM STEM GUIDE NUT	1	BRONZE
4	BOTTOM CUP FOLLOWERS (SET OF 2)	1	BRONZE
5	PISTON CUP PACKING	2	LEATHER
6	BOTTOM STEM LOCK NUT	1	BRONZE
7	STEM NUT	1	BRONZE
8	SEAT DISC	1	BRONZE
9	SEAT PACKING	1	POLYURETHANE
10	SEAT PACKING SUPPORT	1	BRONZE
11	STEM	1	BRONZE
12	MAIN CUP PLATES (SET OF 2)	1	BRONZE
13	MAIN CUP PACKING	2	LEATHER
14	MAIN BUSHING	1	BRONZE
15	TOP STEM NUT	1	BRONZE
16	BOTTOM CAP	1	CAST IRON
17	NEEDLE VALVE	1	BRONZE
18	ISOLATION VALVE	1	BRONZE
20	INDICATOR ROD	1	BRONZE
21	INDICATOR STUFFING BOX	1	BRONZE
22	BOLTS & NUTS (SEAT RING)	VARY	BRONZE
23	BOTTOM CAP CYLINDER	1	BRONZE
24	SEAT RING	1	BRONZE
25	STRAINER	1	BRONZE/STAINLESS
27	3 WAY SOLENOID	1	BRONZE/STAINLESS
29	LIMIT SWITCH ASSEMBLY	1	BRONZE/STAINLESS
	BOLTS & NUTS (TOP & BOTTOM CAP)	VARY	STAINLESS
	BOLTS & NUTS (CUP PLATES)	VARY	BRONZE
	BOLTS (BOTTOM CAP CYLINDER)	1	TEFLON
	INDICATOR ROD PACKING (SET)	3	COMPOSITION
	COVER & MAIN BUSHING GASKETS	3	COMPOSITION
	STEM GASKETS	3	COMPOSITION

VALVE SIZE (IN)	ASME B16.1 CLASS	SHIPPING WEIGHT (LBS)	DIMENSIONS (INCHES)					
			A	B	C&D	E	F	
2	125	235	14	6	4-3/4	7	7	
	250	275	14-5/8	6-1/2	4-3/4	7	7	
2.5	125	235	14	7	4-3/4	7	7	
	250	275	14-5/8	7-1/2	4-3/4	7	7	
3	125	235	14	7-1/2	4-3/4	7	7	
	250	275	14-5/8	8-1/4	4-3/4	7	7	
4	125	235	14	9	4-3/4	7	7	
	250	275	14-5/8	10	4-3/4	7	7	
6	125	375	17-3/4	11	6-5/8	9	9	
	250	430	17-3/4	12-1/2	6-5/8	9	9	
8	125	690	24	13-1/2	8-3/4	12-1/2	12-1/2	
	250	750	24-15/16	15	8-3/4	12-1/2	12-1/2	
10	125	920	24-7/8	16	10	14-1/4	14-1/4	
	250	1000	26-1/4	17-1/2	10	14-1/4	14-1/4	
12	125	1375	30	19	12	15-1/2	15-1/2	
	250	1475	31-1/2	20-1/2	12	15-1/2	15-1/2	
14	125	1770	34-1/4	21	14	18	18	
	250	1850	35-3/4	23	14	18	18	
16	125	2400	37-7/8	23-1/2	15	21-1/2	21-1/2	
	250	2600	39-1/4	25-1/2	15	21-1/2	21-1/2	
18	125	3300	41-7/8	25	18-3/8	24	24	
	250	3500	41-7/8	28	18-3/8	24	24	
20	125	3850	42-3/8	27-1/2	18-3/8	24	24	
	250	3800	42-3/8	30-1/2	18-3/8	24	24	
24	125	5200	47	32	20	25	25	
	250	5500	47	36	20	25	25	
30	125	9800	63-3/4	38-3/4	26-1/4	34	34	
	250	10800	65-1/16	43	26-1/4	34	34	
36	125	11800	65	46	26-1/4	34	34	
	250	12800	65	50	26-1/4	34	34	

ROSS VALVE MFG. CO., INC.

6 OAKWOOD AVENUE - TROY, NEW YORK, 12180 - TEL. (518) 274 0961
 POST OFFICE BOX 595 - TROY, NEW YORK, 12181 - FAX (518) 274 0210
 WEBSITE: www.rossvalve.com - E-MAIL: sales@rossvalve.com

DRAWING	45WR-LS	DATE	4-05-06 CAP
GLOBE	BODY 2" - 36"	NO SCALE	FIGURE 14

MODEL 45WR-LS

DEEP WELL CONTROL VALVE WITH LIMIT SWITCH ASSEMBLY

THIS PRINT CONTAINS CONFIDENTIAL INFORMATION WHICH IS THE PROPERTY OF ROSS VALVE BY ACCEPTING THIS INFORMATION THE BORROWER AGREES THAT IT WILL NOT BE USED FOR ANY PURPOSE OTHER THAN THAT WHICH IT IS LOANED.
 NOTE: The Ross Valve Mfg. Co., Inc., reserves the right to modify valve construction which will result in equal or superior performance to existing designs. These modifications may be made at any time and at the sole discretion of the manufacturer.

DIMENSIONS

Globe Body Minimum Clearances

Piston Valve Sizes: 4" - 36"

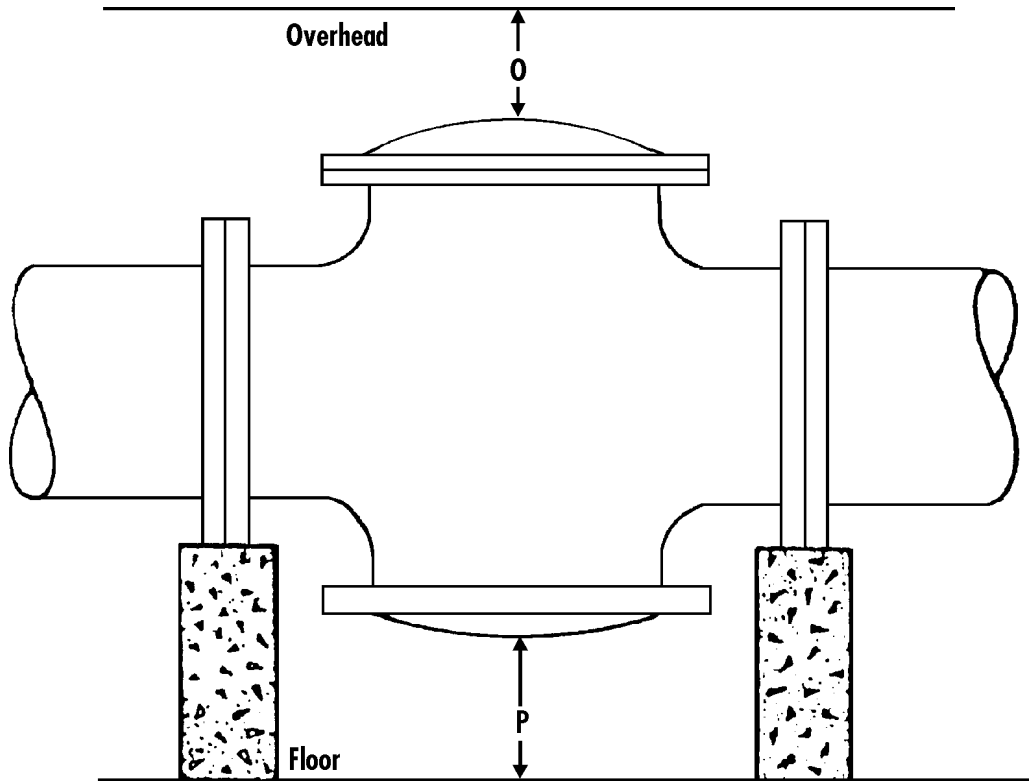

Size (Inches)	4"	6"	8"	10"	12"	14"	16"	18"	20"	24"	30"	36"
O	14	16	18	21	23	28	28	33	33	36	43	46
P	4 1/2	5 1/2	6 1/2	1	1	1	1	1	1	1	1	1

Note

1. Dimension "O" is clearance for removal of the top cap and piston for repacking the main valve. Additional working space for the convenience of the service man should be considered above as well as around the valve.
2. Dimension "P" as listed is the desirable clearance under the valve for removal of the STANDARD bottom cap. This dimension may be reduced to 1 inch for all valves on special applications.

Note

- A. **Do not obstruct vent hole located at the center of the bottom cap.**
- B. Consideration should be given for installation of valves 14" or larger under manhole in the roof of the valve vault or for additional clearance above the valve since a mechanical hoist will probably be required for removal of the piston. An eye bolt or hook cast in the cover slab over the center of the valve is useful.
- C. If clearance under the valve is limited, dimensions "O" and "P" can be modified. Consult the factory concerning special applications.

Features

- Designed for high flow and high pressure service.
- Direct acting, requires no minimum operating pressure.
- Choice of metal seating materials to handle aggressive fluids, or resilient seating for airtight shutoff.
- Ideal for power plants and similar applications.

Construction

Valve Parts in Contact with Fluids		
Body	Brass	304 Stainless Steel
Disc	303 Stainless Steel (Metal), PA or Brass (Resilient)	
Seats	NBR, Phosphor Bronze	303 Stainless Steel
Core Tube	305 Stainless Steel	
Core and Plugnut	430 F Stainless Steel	
Springs	302 Stainless Steel, 17-7PH or Inconel	
Shading Coil	Copper	Silver
Gaskets	NBR	PTFE

Electrical

Standard Coil and Class of Insulation	Watt Rating and Power Consumption				Spare Coil Part Number			
	DC Watts	AC			General Purpose		Explosionproof	
		Watts	VA Holding	VA Inrush	AC	DC	AC	DC
F	-	20.1	43	240	272610	-	272614	-
H	36.2	28	60	330	222345	222184	222345	222184
H	-	16.1	35	180	272810	-	272814	-
H	-	28.2	50	385	224195	-	224195	-

Standard Voltages: 24, 120, 240, 480 volts AC, 60 Hz (or 110, 220 volts AC, 50 Hz). 6, 12, 24, 120, 240 volts DC. Must be specified when ordering.

Note: 125 and 250 volts DC are battery voltages applied in power plants. Special AC and DC constructions are available to pilot power plant control valves. Consult your local ASCO sales office for details.

Solenoid Enclosures

Standard: Red-Hat II - Watertight, Types 1, 2, 3, 3S, 4, and 4X; Red-Hat - Type 1.
Optional: Red-Hat II - Explosionproof and Watertight, Types 3, 3S, 4, 4X, 6, 6P, 7, and 9; Red-Hat - Explosionproof and Watertight, Types 3, 4, 4X, 7, and 9. See footnote on next page.
(To order, add prefix "EF" to catalog number.)
See *Optional Features Section* for other available options.

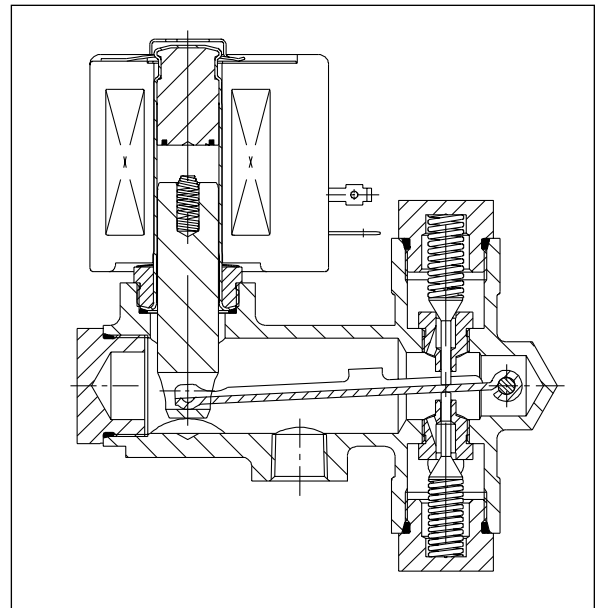
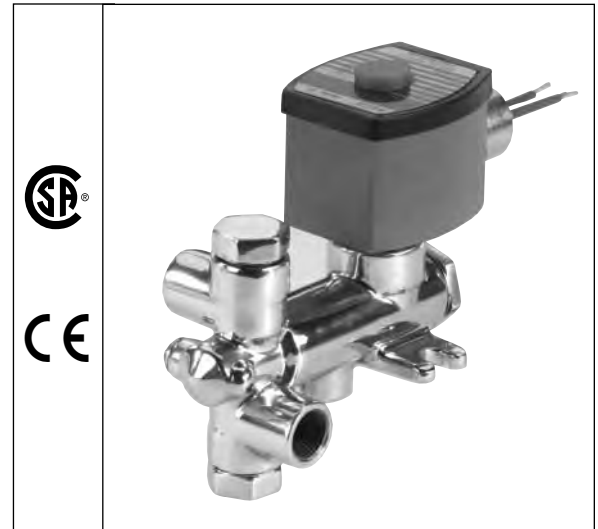

Nominal Ambient Temperature Ranges:

Class F Coils AC: 32°F to 125°F (0°C to 52°C)

Class H Coils AC: 32°F to 140°F (0°C to 59°C)

Class H Coils DC: 32°F to 77°F (0°C to 25°C)
(104°F/40°C occasionally)

Refer to *Engineering Section* for details.

Approvals:

CSA certified. Meets applicable CE directives.

Refer to *Engineering Section* for details.

INSTALLATION AND MAINTENANCE INSTRUCTIONS

3-WAY DIRECT ACTING SOLENOID VALVES

NORMALLY CLOSED, NORMALLY OPEN AND UNIVERSAL OPERATION

1/8, 1/4, 3/8 AND 1/2" NPT — METAL TO METAL SEATING

BULLETINS
8300
8302
8315

ASCO

FORM NO. V-5941

DESCRIPTION

Bulletin 8300's are 3-way, direct acting solenoid valves having only four moving parts - a core, a lever and two poppet type valve discs. Valves are supplied with stainless steel seats and discs and valve bodies of brass, steel or stainless steel construction. Standard valves have a General Purpose, NEMA Type 1 Solenoid Enclosure. Bulletin 8315 valves are identical to Bulletin 8300 valves except they are designed for higher temperature service.

Bulletin 8302's are the same as Bulletins 8300 except the solenoids are equipped with an enclosure which is designed to meet NEMA Type 4 Watertight, NEMA Type 7 (C or D) Hazardous Locations - Class I, Groups C or D and NEMA Type 9 (E, F or G) Hazardous Locations - Class II, Groups E, F or G. Installation and Maintenance Instructions for the Explosion-Proof/Watertight Solenoid Enclosure are shown on Form No. V-5381.

OPERATION

Normally Closed (Suffix Letter "F")

Solenoid De-energized: Flow is from Cylinder Connection (1) to Exhaust Connection (3). Pressure Connection (2) is closed.

Solenoid Energized: Flow is from Pressure Connection (2) to Cylinder Connection (1). Exhaust Connection (3) is closed.

Normally Open (Suffix Letter "G")

Solenoid De-energized: Flow is from Pressure Connection (3) to Cylinder Connection (1). Exhaust Connection (2) is closed.

Solenoid Energized: Flow is from Cylinder Connection (1) to Exhaust Connection (2). Pressure Connection (3) is closed.

Universal (Suffix Letter "U")

Solenoid De-energized: Flow is from Connection (3) to Connection (1) or Connection (1) to Connection (3). Connection (2) is closed.

Solenoid Energized: Flow is from Connection (1) to Connection (2) or Connection (2) to Connection (1). Connection (3) is closed.

NOTE: Operation forms are identified by catalog suffix letters as follows:

Suffix Letter "F" Normally Closed Operation
Suffix Letter "G" Normally Open Operation
Suffix Letter "U" Universal Operation

CHANGING OPERATION FORMS

Universal valves (U) may be used for any operation form without internal changes. However, normally closed (F) and normally open (G) valves cannot be used for a different operation form unless internal parts (upper and lower springs) are changed. Consult factory for new internal parts and nameplate for proper valve identification. Refer to "NEW SPRING INSTALLATION" Section when changing operation forms.

IMPORTANT: No minimum operating pressure is required.

FLOW DIAGRAMS

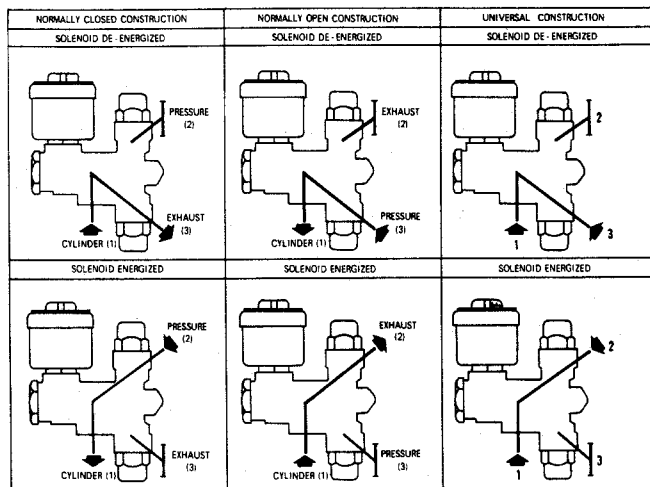

NOTE: PORT MARKINGS 1, 2 AND 3 CORRESPOND DIRECTLY TO A, B, AND C.

MANUAL OPERATOR (Optional)

Valves with Suffix "MO" after catalog number are provided with a manual operator which allows operation when desired or during an interruption of electrical power. To actuate valve manually, push knob upward and rotate one half (1/2) turn. Valve will now be in same position as when solenoid is energized. To disengage manual operator, rotate manual operator approximately one half (1/2) turn until guide pin in manual operator stem engages slots in stuffing box bonnet and drops down. CAUTION: For valve to operate electrically, manual operator stem must be fully retracted.

INSTALLATION

Check nameplate for correct catalog number, pressure, voltage and service.

POSITIONING

Valve must be mounted with the solenoid vertical and upright.

MOUNTING

For mounting bracket mounting dimensions, refer to Figure 3.

PIPING

Connect piping to valve according to markings on valve body. The form of flow is indicated by the Suffix Letters ("F," "G" or "U") following the valve catalog number on nameplate. Refer to flow diagrams provided. Apply pipe compound sparingly to male pipe threads only; if applied to valve threads, it may enter the valve and cause operational difficulty. Pipe strain should be avoided by proper support and alignment of piping. When tightening pipe, do not use valve as a lever. Wrenches applied to valve body or piping are to be located as close as possible to connection point.

IMPORTANT: For protection of the solenoid valve, install a strainer or filter suitable for the service involved in the inlet side as close to the valve as possible. Periodic cleaning is required depending on the service conditions. See Bulletins 8600, 8601 and 8602 for strainers.

WIRING

Wiring must comply with Local and National Electrical Codes. Housings for all solenoids are provided with connections or accommodations for 1/2 inch conduit. The general purpose solenoid enclosure may be rotated to facilitate wiring by removing the retaining cap or clip. CAUTION: When metal retaining clip disengages, it will spring upward. Rotate enclosure to desired position. Replace retaining cap or clip before operating.

NOTE: Alternating Current (A-C) and Direct Current (D-C) solenoids are built differently. To convert from one to the other, it is necessary to change the complete solenoid base sub-assembly, core/spring sub-assembly or core.

SOLENOID TEMPERATURE

Standard catalog valves are supplied with coils designed for continuous duty service. When the solenoid is energized for a long period, the solenoid enclosure becomes hot and can be touched with the hand for only an instant. This is a safe operating temperature. Any excessive heating will be indicated by the smoke and odor of burning coil insulation.

MAINTENANCE

WARNING: Turn off electrical power and depressurize valve before making repairs. It is necessary to remove valve from pipe line for repairs.

PREVENTIVE MAINTENANCE

1. Keep the medium flowing through the valve as free from dirt and foreign material as possible.
2. While in service, operate the valve at least once a month to insure proper opening and closing.
3. Periodic inspection (depending on medium and service conditions) of internal valve parts for damage or excessive wear is recommended. Thoroughly clean all parts. Replace any parts that are worn or damaged.

IMPROPER OPERATION

1. **Faulty Control Circuit:** Check the electrical system by energizing the solenoid. A metallic click signifies solenoid is operating. Absence of the click indicates loss of power supply. Check for loose or blown-out fuses, open-circuited or grounded coil, broken lead wires or splice connections.
2. **Burned-Out Coil:** Check for open-circuited coil. Replace coil if necessary.
3. **Low Voltage:** Check voltage across the coil leads. Voltage must be at least 85% of nameplate rating.
4. **Incorrect Pressure:** Check pressure at the solenoid valve. Pressure to the valve must not exceed that stamped on nameplate.
5. **Incorrect Pressure Connection:** Refer to valve catalog suffix letter on nameplate and flow diagrams.
6. **Excessive Leakage:** Disassemble valve and clean all parts and passageways. Leakage between the seats and discs is usually caused by lodgement of foreign material on the valve seating surfaces. The foreign material, though not present upon examination, may have damaged the seating surfaces enough to cause leakage. Leakage thru the stainless steel (metal to metal) seats can usually be corrected by regrinding and lapping (see section on grinding and lapping). If leakage should still exist, the seating surfaces may be worn more than grinding and/or lapping can correct. In that case, replace both seats and discs. NOTE: New seats and discs must be checked and adjusted for proper stroke where necessary. Refer to paragraphs on "NEW SEAT AND DISC INSTALLATION" under "INSTALLATION OF NEW SPARE PARTS KIT" Section.

COIL REPLACEMENT (Refer to Figure 4)

Turn off electrical power supply and disconnect coil lead wires.

1. Remove retaining cap or clip, nameplate and solenoid cover. CAUTION: When metal retaining clip disengages, it will spring upward.
2. Slip yoke containing coil, sleeves and insulating washers off the solenoid base sub-assembly. For D-C Construction, a fluxplate over the coil replaces the yoke and sleeves. Insulating washers are omitted when a molded coil is used.
3. Reassemble in reverse order of disassembly paying careful attention to exploded view provided for identification and placement of parts.

CAUTION: Solenoid must be fully reassembled as the housing and internal parts are part of and complete the magnetic circuit. Place an insulating washer at each end of coil, if required.

ASCO Valves

ASCO

VALVE DISASSEMBLY FOR GENERAL CLEANING AND INSPECTION

(Refer to Figure 4)

Depressurize valve and turn off electrical power supply. It is strongly recommended that the valve be removed from the pipe line for ease of maintenance. If it is not practical to remove the valve from the pipe line and resetting of strokes is required or a new Spare Parts Kit is to be installed, consult factory for special bonnet tools which are available. When consulting the factory, be sure to include the valve catalog number and serial number from the nameplate on the valve.

1. Disassemble valve in an orderly fashion paying careful attention to exploded view provided for identification of parts.
2. Remove retaining cap or clip and slip the entire solenoid enclosure off the solenoid base sub-assembly. CAUTION: When metal retaining clip disengages, it will spring upward. For Explosion-Proof/Watertight Enclosure, refer to Installation and Maintenance Instructions Sheet, Form No. V-5381.
3. Unscrew solenoid base sub-assembly and remove bonnet gasket. For Explosion-Proof/Watertight Enclosure, a special bonnet adapter wrench is available, Order No. 102-649-1.
4. Unscrew disc guide caps (both ends) and remove disc guide cap gaskets, upper and lower springs and discs. CAUTION: Tag springs and discs as they are not interchangeable and must be returned to the original location. Tag upper and lower for ease of identification.
5. Remove end cap, end cap gasket and slip core/spring sub-assembly (A-C Construction) or core (D-C Construction) off the end of the valve lever and lift it out through solenoid base sub-assembly opening.
6. Inspect upper and lower valve seats but do not remove from valve body unless installing a complete Spare Parts Kit.
7. Clean all parts thoroughly and replace worn or damaged parts with a complete Spare Parts Kit. If a Spare Parts Kit is required, refer to section on "INSTALLATION OF NEW SPARE PARTS KIT" for complete rebuild. **IMPORTANT: Install all new parts. Do not retain any old parts when rebuilding valve. If only partial installation is made, valve malfunction may occur.**

VALVE REASSEMBLY

1. Reassemble in reverse order of disassembly paying careful attention to exploded view provided for identification and placement of parts.
2. Lubricate all gaskets with Dow Corning's Valve Seal silicone lubricant or an equivalent high grade silicone grease.
3. Replace core/spring sub-assembly (A-C Construction) or core (D-C Construction) through solenoid base sub-assembly opening and engage with lever.
4. Install end cap gasket and end cap. Torque end cap to 55 ± 5 foot-pounds [74.6 ± 6.8 newton meters].
5. Replace bonnet gasket and solenoid base sub-assembly. Torque solenoid base sub-assembly to 175 ± 25 inch-pounds [19.8 ± 2.8 newton meters].
6. Replace solenoid enclosure and retaining cap or clip.
7. Install valve discs. If lapping is required, refer to "LAPPING SEATS AND DISCS" Section.
8. For stroke setting requirements (adjustment of valve discs) refer to "NEW SEAT AND DISC INSTALLATION" Paragraphs under "INSTALLATION OF NEW SPARE PARTS KIT" Section.
9. Install upper and lower springs. Refer to "NEW SPRING INSTALLATION" Section.
10. Replace disc guide cap gaskets and disc guide caps (both ends). Torque disc guide caps to 180 ± 15 inch-pounds [20.3 ± 1.7 newton meters].
11. After maintenance, operate the valve a few times to be sure of proper opening and closing. A metallic click signifies that the solenoid is operating.

NEW SPRING INSTALLATION (Refer to Figures 1 and 4)

When it is desired to change to a different form of flow or operating conditions, new upper and lower springs corresponding to the new requirements must be installed. Depressurize valve and turn off electrical supply. Remove the two disc guide caps and old springs. Install new springs in their proper location as indicated on the factory labeled tags. Replace disc guide caps and torque to 180 ± 15 inch-pounds [20.3 ± 1.7 newton meters]. The smaller diameter end of the Type "38" body springs faces the discs.

NOTE: The lower spring is always the weaker of the two and should always be located at the bottom. If the springs are installed in the wrong position, the valve will not function properly.

A method to determine which spring is the weaker is by placing the two springs on the shaft of a screwdriver or similar tool and compressing them. The spring which compresses to the "L" dimension (Figure 1) first is the weaker of the two springs and should be placed on the bottom.

MANUAL OPERATOR DISASSEMBLY AND REASSEMBLY

(Refer to Figure 4)

1. Unscrew stuffing box bonnet from valve body. (Be certain manual operator stem is fully retracted). Remove the manual operator intact.
2. Remove gasket from stuffing box bonnet.
3. Press or drive out knob/stem pin from operating knob and stem. CAUTION: When removing knob/stem pin from knob/stem sub-assembly, do not let parts fly apart.
4. Remove spring and slide stem out of stuffing box bonnet. CAUTION: Before sliding stem thru stuffing box bonnet, be certain there are no burrs on stem from removing knob/stem pin. Do not damage captive gasket seat ("O"-ring) in stuffing box sub-assembly.
5. All parts are now accessible for cleaning.
6. Reassemble in reverse order of disassembly paying careful attention to exploded view provided for identification and placement of parts.
7. Torque stuffing box bonnet to 16 ± 3 foot-pounds [22.7 ± 4.1 newton meters].

SPARE PARTS KITS

Spare Parts Kits and Coils are available for ASCO valves. Parts marked with an asterisk (*) are supplied in Spare Parts Kits.

ORDERING INFORMATION FOR SPARE PARTS KITS

When Ordering Spare Parts Kits or Coils, Specify Valve Catalog Number, Serial Number and Voltage.

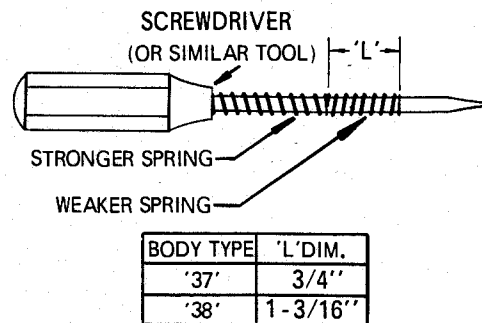

Figure 1. Method to Determine Weaker Spring

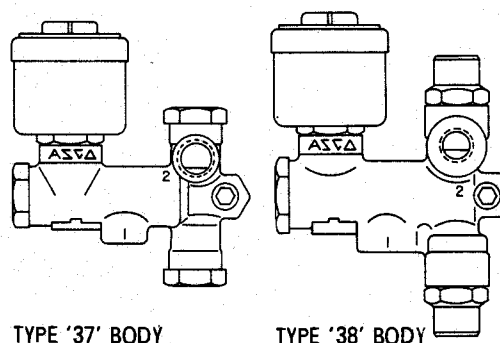

Figure 2. Identification of Body Type

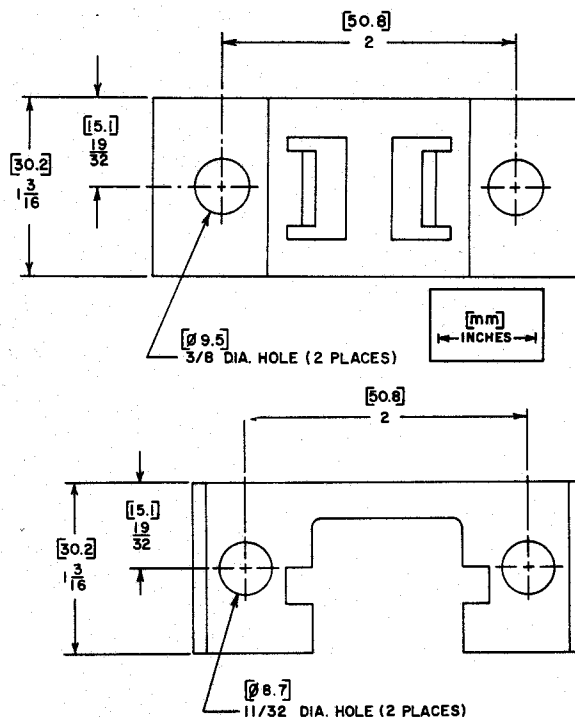

Figure 3. Mounting Bracket Dimensions

CONNECTION 'I' MACHINED INTO END CAP (WHEN MANUAL OPERATOR IS USED)

PARTS INCLUDED IN SPARE PARTS KITS*

A - C (ALTERNATING CURRENT) CONSTRUCTION SHOWN

IMPORTANT TAG PARTS AS THEY ARE REMOVED

INSERT CORE/SRING SUB-ASSEMBLY THRU UPPER BODY OPENING. ENGAGE IN END OF VALVE LEVER.

PARTIAL VIEW OF BODY TYPE 38 TO SHOW VARIATION OF BODY CONFIGURATION AND PARTS.

TORQUE STUFFING BOX BONNET TO 16 ± 3 FOOT-POUNDS (22.7 ± 4.1 NEWTON METERS)

VIEW SHOWING MANUAL OPERATOR THREADED INTO CONNECTION 'I' ON UNDERSIDE OF VALVE BODY

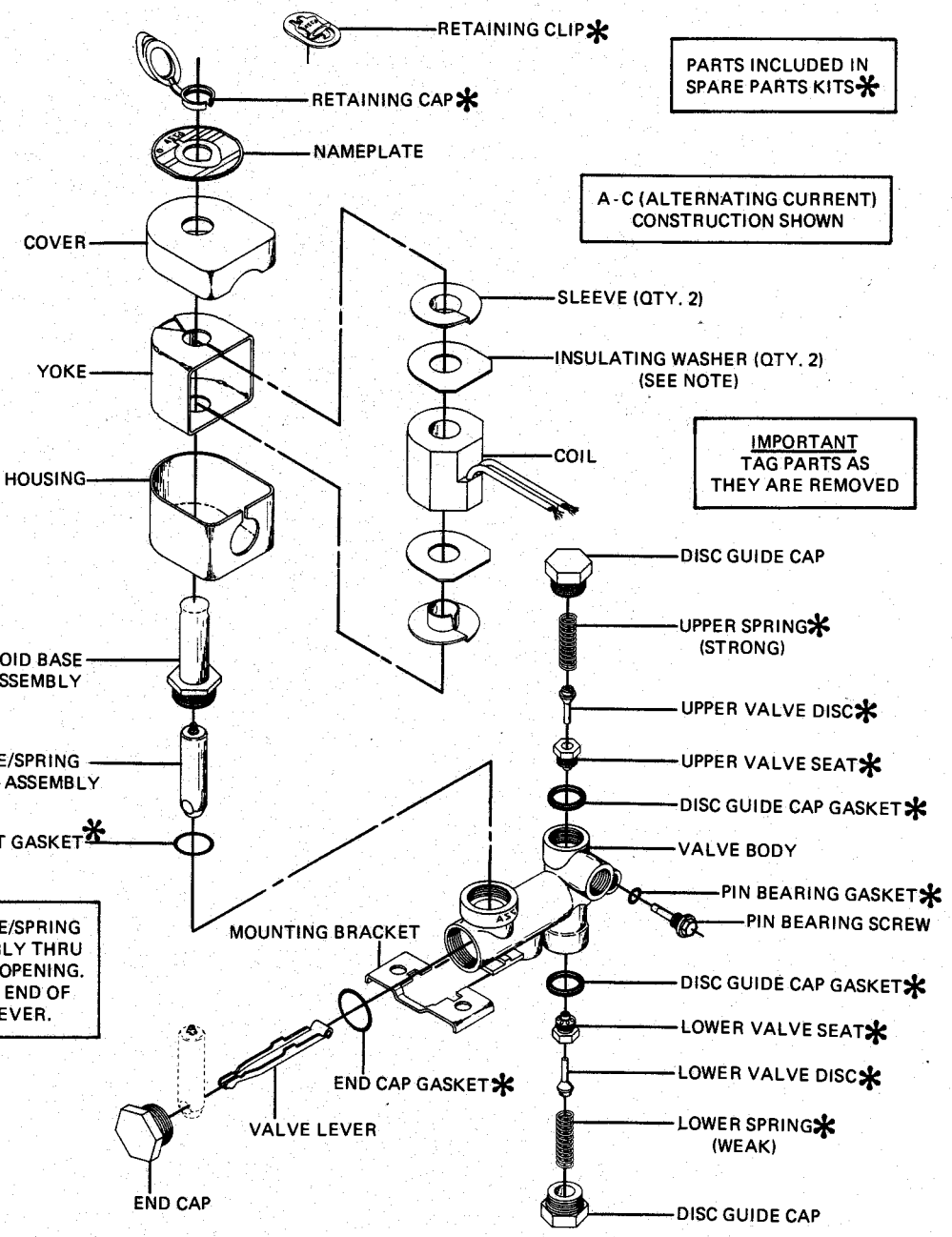

NOTE: INSULATING WASHERS (2) ARE OMITTED WHEN A MOLDED COIL IS USED.

PART NAME	TORQUE VALUE INCH-POUNDS	TORQUE VALUE NEWTON METERS
PIN BEARING SCREW	55 ± 5	$6.2 \pm .6$
SOLENOID BASE SUB-ASSEMBLY	175 ± 25	19.8 ± 2.8
VALVE SEATS (UPPER & LOWER)	80 ± 8	$9.0 \pm .9$
DISC GUIDE CAPS (UPPER & LOWER)	180 ± 15	20.3 ± 1.7
END CAP	FOOT-POUNDS 55 ± 5	74.6 ± 6.8

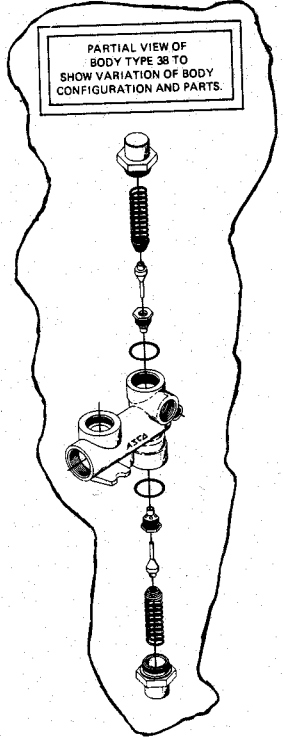

Figure 4.

Bulletin 8300
Body Type 37 - Metal to Metal Seating
General Purpose Solenoid Enclosure Shown.
For Explosion-Proof/Watertight Solenoid Enclosure Used on Bulletin 8302 etc., See Form No. V-5381

LAPPING SEATS AND DISCS

Depressurize valve and proceed in the following manner:

CAUTION: Tag upper and lower springs and upper and lower discs as they are not interchangeable and must be returned to original locations.

1. Apply a small amount of fine grinding compound to the beveled seating surface of the disc and insert the disc in the proper valve seat (do not remove seat from body). A fine grade of grinding compound Grit Size 900 is recommended. NOTE: If new seats and discs are being installed, lap them before installation in the valve. Be sure to install seats and discs in mated sets.
2. Use a screwdriver in the slot provided in the disc and grind by rotating the disc back and forth using light pressure. After an evenly lapped surface has been obtained, repeat the grinding operation on the other disc.
3. Wipe all parts clean of grinding compound.
4. Reassemble parts in reverse order of disassembly replacing discs and springs in original positions. Be sure the weaker spring is located at the bottom and stronger spring at the top. If discs or springs are incorrectly reassembled, the valve will not function properly. To determine the weaker spring, refer to "NEW SPRING INSTALLATION" Section.

INSTALLATION OF NEW SPARE PARTS KITS

Depressurize valve and turn off electrical power supply. Disassemble valve in an orderly fashion paying careful attention to exploded views provided for identification of parts. For ease of maintenance, valve should be removed from the pipe line. Spare Parts Kits include springs for all three forms of flow (F, G and U). Check the catalog number suffix on the nameplate to determine which form of flow you have. For example, a Form "F" valve is normally closed operation. When the correct springs have been chosen, immediately discard remaining two (2) sets of springs to avoid any difficulty.

1. Remove retaining cap or clip and slip the entire solenoid enclosure off the solenoid base sub-assembly. CAUTION: When metal retaining clip disengages, it will spring upward. For Explosion-Proof/Watertight Solenoid Enclosure, refer to Form V-5381 for disassembly.
2. Unscrew solenoid base sub-assembly and remove bonnet gasket. For Explosion-Proof/Watertight Solenoid Enclosure, a special wrench is required to remove the solenoid base sub-assembly. Wrench adapter Order No. 102-649-1.
3. Unscrew disc guide cap (both ends) and remove disc guide cap gaskets, upper and lower springs and discs.
4. Remove upper and lower valve seats using a 1/2 inch thin wall socket wrench.
5. Remove end cap and end cap gasket. Slip core/spring sub-assembly (A-C Construction) or core (D-C Construction) off the end of the valve lever and lift out through the solenoid base sub-assembly opening.
6. Remove pin bearing screw and pin bearing gasket.
7. Slide valve lever out through the end cap opening of the valve body.
8. All parts are now accessible for replacement. Clean all internal passageways. Install a complete Spare Parts Kit. **IMPORTANT: Install all new parts. Do not retain any old parts when rebuilding valve.**
9. Reassemble in reverse order of disassembly paying careful attention to exploded views provided for identification and placement of parts.
10. Lubricate all gaskets with Dow Corning's Valve Seal silicone lubricant or an equivalent high grade silicone grease.
11. Insert valve lever and replace pin bearing gasket and pin bearing screw through the valve lever. Torque pin bearing screw to 55 ± 5 inch-pounds [$6.2 \pm .6$ newton meters].
12. Position core/spring sub-assembly (A-C Construction) or core (D-C Construction) thru solenoid base sub-assembly opening and engage with valve lever. Install end cap gasket and end cap. Torque end cap to 55 ± 5 foot-pounds [74.6 ± 6.8 newton meters].
13. Replace bonnet gasket and solenoid base sub-assembly. Torque solenoid base sub-assembly to 175 ± 25 inch-pounds [19.8 ± 2.8 newton meters].
14. The stainless steel seats and discs (metal to metal seating) provided in the Spare Parts Kit have already been coined, however, lapping of the seats and discs is required. Refer to "LAPPING SEATS AND DISCS" Section. When lapping is complete, be sure to install seats and discs in mated sets.
15. Install upper and lower valve seats using a small amount of pipe compound on the seat threads to avoid possible leakage. Torque upper and lower valve seats to 80 ± 8 inch-pounds [$9.0 \pm .9$ newton meters].
16. Replace solenoid enclosure and retaining cap or clip. For Explosion-Proof/Watertight Solenoid Enclosures, refer to Form No. V-5381.

NEW SEAT AND DISC INSTALLATION

17. New upper and lower seats and discs cannot be installed without making some minor adjustments. It is important that the stroke of the valve discs be set carefully in order to obtain the proper orifice opening and reliable operation of the valve. Check valve nameplate for the catalog number and refer to "Stroke Chart," Form No. V-5940 for stroke setting requirements. Refer to Figure 5 for the method of measuring the stroke. Spaces are provided on this sheet for your calculations.
18. Place the valve in a vertical and upright position. Install new upper disc and use a depth gauge to measure distances. NOTE: Solenoid and core/spring sub-assembly or core must be assembled in valve when strokes are measured.
19. With valve de-energized, measure Dimension "A." Dimension "A" is from the top of the valve body to the top of the upper disc as illustrated in Figure 5.
20. With valve energized, measure Dimension "B." Dimension "B" is from the top of the valve body to the top of the upper disc as illustrated in Figure 5.
21. Dimension "A" - "B" = upper disc stroke.

The differences between the two distances "A" minus "B" is the upper disc stroke. If the stroke is more than can be allowed in the "Stroke Chart," Form No. V-5940 (according to catalog number and body type), the end of the upper disc which contacts the valve lever must be ground off until the proper stroke is obtained. After grinding, the end of the disc stem must be crowned slightly and polished smooth.

22. Replace upper valve spring (strong spring), disc guide cap with disc guide cap gasket attached. Torque disc guide cap to 180 ± 15 inch-pounds [20.3 ± 1.7 newton meters].
23. Turn valve upside-down to install lower disc and follow the same procedure used in setting the upper disc stroke to set the lower disc stroke. In general, more adjustment grinding of disc stem is required to set lower disc stroke.
24. With valve energized, measure Dimension "C."
25. With valve de-energized, measure Dimension "D."
26. Dimension "C" - "D" = lower stem stroke.
27. When the strokes have been set in accordance with Figure 5 and the "Stroke Chart," Form No. V-5940, a gap will automatically be obtained between the lower disc stem and the lever when the solenoid is energized. This gap will assure proper operation of the valve.
28. Replace lower valve spring (weak spring), disc guide cap with disc guide cap gasket attached. Torque disc guide cap to 180 ± 15 inch-pounds [20.3 ± 1.7 newton meters].
29. After maintenance, operate the valve a few times to be sure of proper opening and closing. A metallic click signifies that the solenoid is operating.

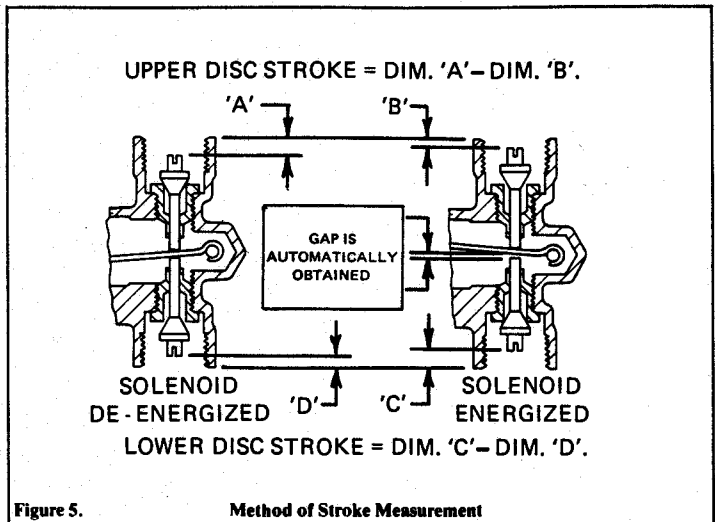

Figure 5. Method of Stroke Measurement

STRAINER

Model Number: 5F-2

Sizes: ½" – 1"

Located: On any external piping

Purpose: To protect external piping and control devices from fouling or damage from foreign particles

Screen: Cylindrical Dutch weave stainless steel wire mesh

Piping Connection: Standard pipe thread

Operation

1. Water enters the cylindrical screen (#2) from the top and passes out through the sides of the cylinder.
2. Any particle too large to pass through .012 inch openings gets trapped in the cylinder, where, unless there is unusual turbulence, they settle at the bottom.

Recommendation

1. Strainer should be "blown down" frequently to remove collected foreign material from the sediment chamber.
2. Strainer screen should be removed occasionally for inspection and thorough cleaning.

Note

1. To clean without shutting down the line, open the flush cock (#5) in the bottom cap (#4) for several seconds.
2. To remove the screen (#2), which requires shutting down the line, unscrew the bottom cap assembly (#5).

Option

Two strainers installed in parallel (with the appropriate isolation valves) to permit uninterrupted service while cleaning.

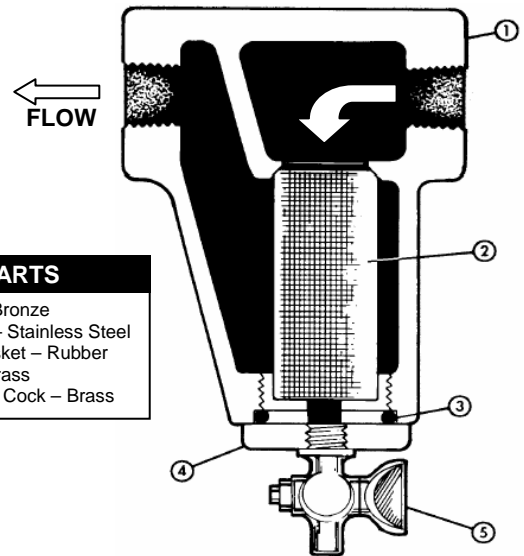

PARTS

1. Body – Bronze
2. Screen – Stainless Steel
3. Cap Gasket – Rubber
4. Cap – Brass
5. Flushing Cock – Brass

NEEDLE VALVE

Sizes: One size fits all piston valves

Primarily Controlled By: Manually Adjusted

Located: On external control circuit of the main valve

Purpose: To limit flow in and out of the operating chamber

Standard Shipped Adjustment:

Course Needle: 5/6 to 2 turns off the seat

Fine Needle: Based on individual specifications

Operation

The simple construction reliably limits maximum flow through the external piping, depending on the position of the adjustable stem/needle (#4) relative to the seat.

1. When the needle (#4) is adjusted counter-clockwise to a raised position,
 - a. More water can pass through the needle valve.
 - b. Water enters (leaves) the operating chamber more quickly.
 - c. The main valve piston moves up and down more quickly.
2. When the needle (#4) is adjusted clockwise to a lowered position,
 - a. Less water can pass through the needle valve.
 - b. Water enters (leaves) the operating chamber more slowly.
 - c. The main valve piston moves up and down more slowly.

Adjustment

To adjust needle valve, which can be done without shutting down the main valve:

1. Remove the hex cap (#2) and lock (#1).
2. With a screw driver;
 - a. Turn the needle (#4) counter-clockwise to raise it
 - b. Turn the needle (#4) clockwise to lower it
3. Once the optimum position is determined, no further adjustment of the needle should be required.

Note

It is advisable to occasionally remove the cap (#2) and lock (#1) and change the position of the needle (#4) momentarily to insure against gradual plugging.

Option

Two separate needle valves on one main valve – Provides independent control of opening and closing speeds.

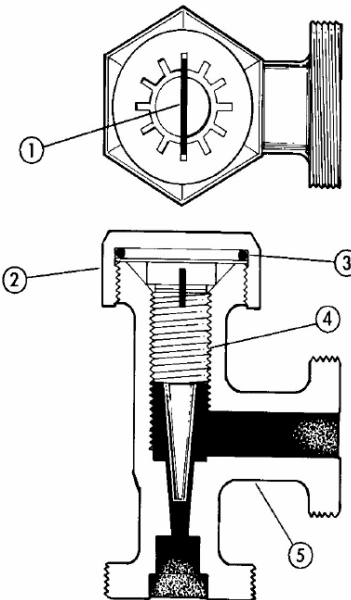
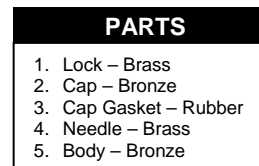

LIMIT SWITCH

Located:

Wherever an electric switch control is needed.

Contact: 10 AMP

Purpose:

1. To signal if the valve is opened or closed.
2. To start or stop allied equipment.

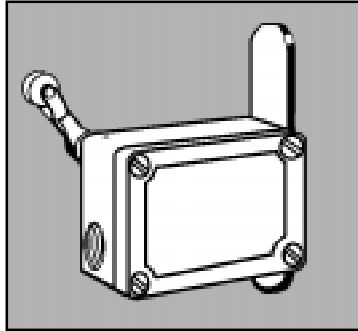

ROSS ADVANTAGE

Because it is waterproof, the switch can be used anywhere.

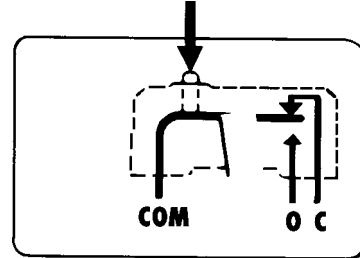

- O - Normally open contact
- C - Normally closed contact
- COM - Common

Operation

Performs as an on/off switch.

Note: A double pole switch (2 N.O. and 2 N.C.) contacts can be supplied as an extra.

Factory: Telephone (518) 274-0961; Fax (518) 274-0210

Limit and Enclosed Switches

OP Series

Enclosed Switches



FEATURES

- Cast aluminum housing
 - Mounts from 4 sides
 - Cover seal, captive cover screws
 - Momentary contact
 - UL Recognized, file #E12252
 - CSA Certified, file #LR57325
 - Grounding screw
 - NEMA 1, 3*, 4* and 13*
- (* Except Q-plunger and high temperature types)

ELECTRICAL RATING

Circuitry	Electrical Rating
<p>Single-pole Double-throw</p>	<p>A</p> <p>UL/CSA Rating: 15 amps, 125, 250 or 480 VAC; 1/8 Hp, 125 VAC; 1/4 Hp, 250 VAC; 1/2 amp, 125 VDC; 1/4 amp, 250 VDC.</p>

OP enclosed switches are precision snap-action switches sealed in rugged cast aluminum housings. Cover and shaft seals keep out moisture and other contaminants on rotary operated switches. The plungers in the Q-plunger version are not sealed.

Refer to page A123 for explosion-proof Type EX switches, which are dimensionally interchangeable with OP switches.

N = Newtons

* Actuation is designated as CW (clockwise) or CCW rotation, when looking at the switch nameplate.

† Choice of levers available for use with OP-AR20:
6PA5-EX (non-sparkling roller), **6PA6-OP** (steel roller), **6PA127-EX** (nylon roller), **6PA130-EX** (CW), **6PA142-EX** (CCW), and **6PA136-EX** (Aluminum rod).

Characteristics: O.F. — Operating Force; P.T. — Pretravel; O.T. — Overtravel; D.T. — Differential Travel

For rapid response – off the shelf service, all **bold face** listings are normally stocked items.

Description	Elec. Rating	Catalog Listing	O.F.	P.T.	O.T.	D.T.
				max. mm in.	max.	max. mm in.
Roller Lever is field adjustable through 360°	A	OP-AR	2,22-5,56 N .5-1.25 lbs.	5,56 (8°)	90°	0,18 (.25°)

OP Enclosed Limit switches

MICRO SWITCH, a Honeywell division

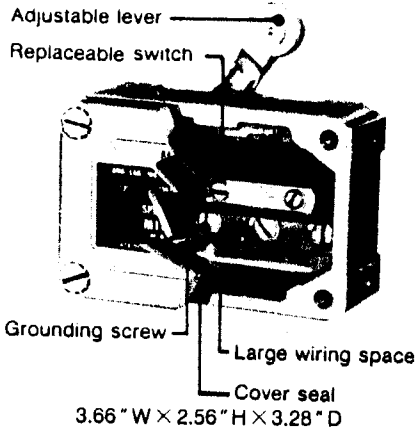

GENERAL INFORMATION

Type OP enclosed switches are precision snap-action switches sealed in rugged cast aluminum housings. Cover and shaft seals provide a degree of protection from moisture and other contaminants on rotary operated switches. The plungers in the Q-plunger versions are not sealed.

Explosion-proof Type EX switches are dimensionally interchangeable with OP switches.

Additional actuators and circuitries are listed in Catalog 40.

For replacement parts and mounting brackets see page B15.

FEATURES

- Cast aluminum housing
- Mounts from 4 sides
- Cover seal, captive cover screws
- Momentary contact
- UL listed and CSA certified
- Grounding screw
- Complies with NEMA 1, 3*, 4*, and 13* (*Except Q-plunger types)

Characteristics:

- O.F. — Operating Force;
- P.T. — Pretravel;
- O.T. — Overtravel;
- D.T. — Differential Travel;
- O.P. — Operating Position

ROLLER LEVER ACTUATED SWITCHES ORDER GUIDE

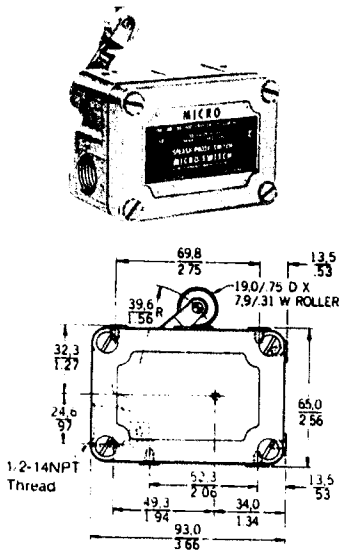

Description		Electrical Data and UL Code	Catalog Listing	O.F.	P.T. max. mm in.	O.T. max.	D.T. max. mm in.
Roller Lever is field adjustable through 360°	CW actuation* SPDT.	15A L96	OP-AR	2,22-5,56N .5-1.25 lbs.	5,56 .219 (8°)	90°	0,18 .007 (.25°)
	CW actuation* High capacity. SPDT.	20A L23	OPA-AR	3,34-8,90 N .75-2 lbs.	5,56 .219 (8°)	25°	0,3 .012 (.4°)
	CW actuation* DPDT.	10A L59	OPD-AR	2,22-6,67 N .5-1.5 lbs.	4,78 .188	25°	2,77 .109 (4°)
	CCW actuation* SPDT.	15A L96	OP-AR30	1,11 N max. 2.5 lbs. max.	1,65 .065 (3.5°)	25°	0,18 .007 (.25°)
	CCW actuation* Basic switch plunger held depressed (normal position) DPDT.	10A L59	OPD-AR30	12,2 N max. 2.75 lbs. max.	5,56 .219 (8°)	25°	2,77 .109 (4°)

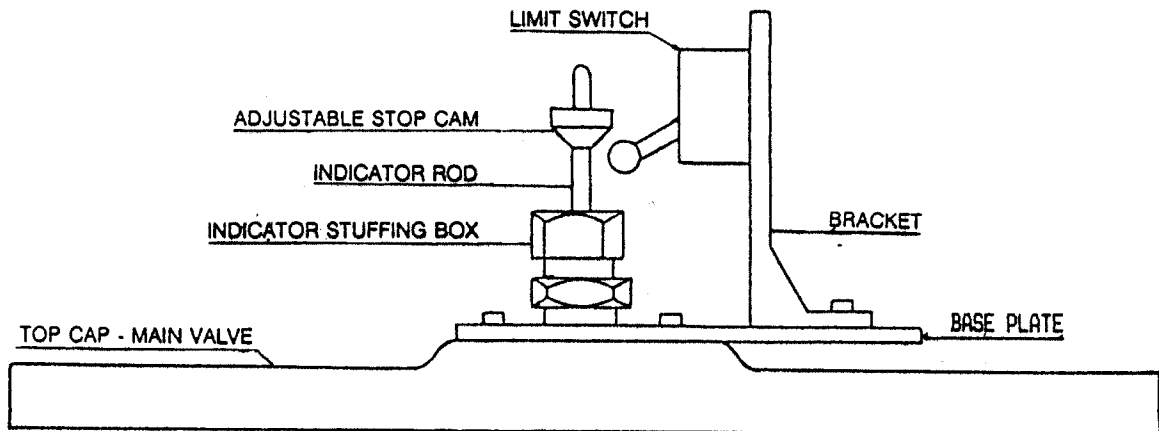

LIMIT SWITCH ASSEMBLY

* Note - Dimension 'I' Minimum Headroom Required - 12"

EX Explosion-Proof and OP Enclosed Switches

ADJUSTING ROLLER ARMS

The roller lever assembly is adjustable through 360° at any of 1,980 positive lock positions at intervals of approximately 0.2°.

To adjust the roller lever to the desired position, hold the hexagon washer with a wrench and loosen lock nut sufficiently to disengage the serrations. Hold shaft in position by means of the hexagon washer so that no torque will be applied to the internal parts of the unit when the lock nut is tightened or loosened. Failure to do so may result in damage to the enclosed switching mechanism.

Moving lever one serration forward or backward with respect to serrations on fluted washer changes the position of the lever approximately 8.2° (see sketch below).

Moving lever and fluted washer, as a unit, one serration forward or backward with respect to serrations on the hexagon washer changes position of the lever 8°. Moving the lever one serration in one direction, and the lever and fluted washer, as a unit, one serration in the other direction, changes position of the arm approximately 0.2°.

After positioning lever arm, tighten lock nut sufficiently to prevent slippage of arm, but avoid over tightening.

Located:

Wherever an electric switch control is needed.

Purpose:

1. To signal if the valve is opened or closed.
2. To start or stop allied equipment.

REPLACING BASIC SWITCH

1. **NOTICE** - Disconnect power supply circuit before opening switch.
2. Remove cover of housing, disconnect the lead-in wires, loosen screws holding the basic switch, then remove the basic switch.
3. Place replacement switch in the insulator, insert the screws, and place basic switch in the housing.
4. Tighten the screws and connect the lead-in wires.
5. Be sure small compression spring is returned to its position between the top of the basic switch and the internal lever (or above internal lever in the case of the CCW actuated switches).

NOTICE

Excessive tightening will also deform the hexagon serrated washer and cause lever assembly to bind.

WARRANTY/REMEDY

Seller warrants its products to be free from defects in design, material and workmanship under normal use and service. Seller will repair or replace without charge any such product it finds to be so defective on its return to Seller within 18 months after date of shipment by Seller. **The foregoing is in lieu of all other expressed or implied warranties (except of title), including those of merchantability and fitness for a particular purpose.** The foregoing is also Purchaser's sole remedy and is in lieu of all other guarantees, obligations, or liabilities or any consequential, incidental, or punitive damages attributable to negligence or strict liability, all by way of example.

While we provide application assistance on MICRO SWITCH products, both personally and thru our literature, it is up to the customer to determine the suitability of the product in the application.

Because it is waterproof, the switch can be used anywhere.

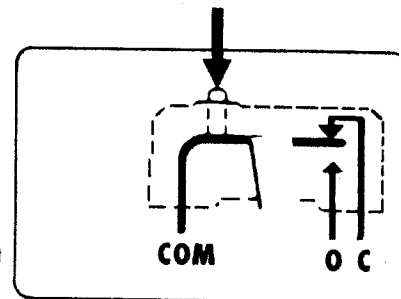

- O - Normally open contact
- C - Normally closed contact
- COM - Common

Note: A double pole switch (2 N.O. and 2 N.C.) contacts can be supplied as an extra.

Operation

Performs as an on/off switch.

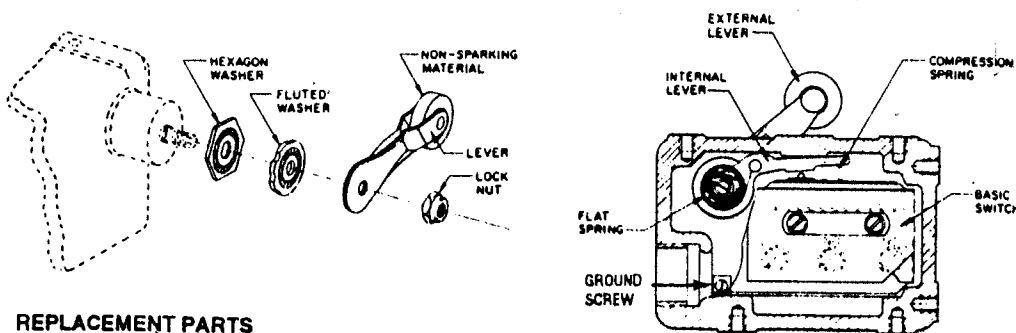

A ground screw is provided for convenient grounding. See drawing.

REPLACEMENT PARTS

Catalog Listing	Description	Elec. Rtg.	Basic Switch Unit	External Actuator	Internal Lever	Springs	Mounting Bracket
OP-AR	Roller arm, CW actuation, SPDT, 15 amp capacity	A	BZ-2R-P4	6PA6-OP*	33PA2-OP	33PA7-EX	15PA85-E
OPD-AR	Roller arm, CW actuation, DPDT, 10 amp capacity	C	DT-2R4-A7	6PA6-OP*		33PA6-EX	15PA65-E

ROSS GLOBE VALVE

PREVENTIVE MAINTENANCE

Intervals of inspection vary from valve to valve. Type of valve, quality of water being handled, rates of flow, operating pressures, and past maintenance practices all have a bearing on the length of service between overhauls.

So some recommendation may guide the operator, we suggest periodic inspections in order to check for proper valve operating pressures, as well as any visual leaks. Should the operator encounter any external leakage, or find any abnormalities in the operating pressures resulting from the operation of the valve, the valve should be scheduled for service.

EVERY TWO (2) MONTHS:

1. Flush the strainer via the flushing cock.
2. Flush the needle valve by turning then needle *clockwise* ½ turn, *counter-clockwise* 2 turns, then *clockwise* 1-1/2 turns to original setting.
3. Visually inspect for leaks around the indicator rod, bottom cap/differential vent hole, or pilot valves (hydraulic & /or solenoid).
4. Inspect drain line connection.

EVERY FOUR (4) MONTHS:

1. Remove and inspect strainer screen.
2. Remove and inspect needle valve, being sure to take note of the needle position away from the seat (number of turns).
3. Same visual inspection as above.

Important: Condition of the main valve packing can be accurately gauged by observing the leakage through the bottom vent hole "C". Negligible leakage usually indicates serviceable packing.

Lubrication: None Required.

Spare Parts: None required, recommended, or supplied unless specified. Under normal operating conditions, no spare parts would be necessary within five (5) years of service. The standard repair kit for Ross valves are in stock at the factory, and available for immediate shipment upon receipt of order with valve serial number (located on metal tag pinned to the top cap of the main valve).

ROSS GLOBE VALVE
INSPECTION - SERVICE RECORD

VALVE LOCATION/I.D. _____

SIZE _____ MODEL _____ SERIAL NO. _____

VALVE - OPEN ~ CLOSED ~ INDICATOR ROD EXPOSED ___ INCHES ABOVE STUFFING BOX CAP

MAIN VALVE OPERATED MANUALLY YES ~ ... NO ~

OPERATING PRESSURES - INLET (SUPPLY) _____ OUTLET (DOWNSTREAM) _____

EXTERNAL LEAKS NONE SLIGHT MAJOR

..... INDICATOR STUFFING BOX ~ ~ ~

..... BOTTOM CAP VENT HOLE ~ ~ ~

..... DIAPHRAGM VENT-HYDRAULIC PILOT ~ ~ ~

..... SOLENOID PILOT EXHAUST PORT ~ ~ ~

OTHER CONDITIONS _____

STRAINER FLUSHED YES ~ NO ~

..... SCREEN EXAMINED . YES ~ NO ~ CLEANED ONLY ~

..... SCREEN CONDITION GOOD ~ POOR ~ INSTALLED NEW SCREEN ~

NEEDLE VALVE(S) (EXAMINE NEEDLE & SEAT FOR WEAR)

..... OPENING CONTROL . CLEANED ~ ADJUSTED ~ SET POINT _____

..... CLOSING CONTROL CLEANED ~ ADJUSTED ~ SET POINT _____

HYDRAULIC PILOT ADJUSTED NO ~ YES ~ _____ TURNS

..... CLOCKWISE ~ .. COUNTER-CLOCKWISE ~ SET POINT _____

..... REBUILT AT FACTORY DATE _____ . IN FIELD DATE _____

..... NEW HYDRAULIC PILOT REPLACEMENT DATE _____

SOLENOID - COIL TESTED NO ~ YES ~ REPLACED ~

..... SEATS - INSPECT & CLEAN _____

..... REBUILT AT FACTORY DATE _____ . IN FIELD DATE _____

..... NEW SOLENOID REPLACEMENT DATE _____

MAIN VALVE INTERNAL CONDITION -

..... MAIN CYLINDER (14) _____

..... BOTTOM CAP CYLINDER (23) _____

..... SEAT DISC/SUPPORT/RING _____

..... BODY TAP CONNECTIONS _____

..... MAIN VALVE REPACKED _____ DATE _____

ACTION RECOMMENDED _____

REPORT BY _____ DATE _____

**ANALYSIS FOR DETERMINING CONDITION RESPONSIBLE
FOR AND CORRECTION OF FAULTY OPERATION**

No. 1 - WHEN VALVE DOES NOT CLOSE

Cause (a): Solenoid Pilot (normally closed) failure – seats fouled.

Correction: Inspect, clean and regrind seats.

Cause (b): Solenoid Pilot (normally open) failure may be result of fouled seats or burned out coil.

Correction: Inspect, clean and regrind seats or replace coil.

Cause (c): Fouled Needle Valve.

Correction: Flush Needle Valve, remove Needle Valve cap and locking device; and with screw drive, turn need *counter-clockwise* 3 full turns. After 2 to 3 minutes of flushing, restore needle to its original position. This correction should be made while water passes through valve.

Cause (d): Sticks or stones lodged under or on seat of Main Valve.

Correction: Dismantle main valve and remove.

Cause (e): Worn leathers - Main Valve.

Correction: Replace leathers.

Cause (f): Isolation valve (18) is closed.

Correction: Open isolation valve.

No. 2 - WHEN VALVE WILL NOT OPEN

Cause (a): Normally Closed Solenoid Pilot may have seats fouled or coil burned out, while Normally Open Solenoid Pilot may have fouled seats.

Correction: Inspect, clean, regrind seats, or replace coil.

Cause (b): Leakage by main cup leathers (13).

Correction: Replace worn leather cups.

Cause (c): Main stem binding due to dirt or sediment lodging behind cup leathers.

Correction: Clean main stem and valve thoroughly.

REPAIR INSTRUCTIONS - GLOBE BODY VALVES

When entering a valve pit to inspect a valve, all regulations regarding Confined Space Entry should be observed.

So some recommendation may guide the operator, we suggest periodic inspections in order to check for proper valve operating pressures as well as any visual leaks. Should the operator encounter any external leakage or find any abnormalities in the operating pressures which appear to be caused by the valve, the valve should be scheduled for service.

A reliable indication of internal packing condition can be obtained by observing any leakage from the vent hole in the center of the bottom cap. When leakage becomes significant, packing replacement should be made. As a general statement, the overall average life of a set of packings is 7 to 10 years. This may vary considerably because of specific operating conditions.

After observing pressures and inspecting for external leakage, the flush cock on the strainer should be opened momentarily to remove accumulated material. The needle valve cap should be removed and the needle closed 1/2 turn, opened 1 full turn, and then closed 1/2 turn to its original position.

STEPS FOR INTERNAL REPAIRS:

All repairs and parts replacement may be made without removing the valve from the line. Internal repairs are made by removing the top cap of the valve. All internals are accessible through the top.

Shut inlet main line isolation valve, then shut outlet main line isolation valve. Open gauge cocks to de-pressurize the valve.

Remove indicator rod by inserting a nail through hole and unscrewing. Do not pull through stuffing box. Then remove top cap bolts and top cap. Be careful not to bend indicator rod.

In 8" and larger valves, withdraw piston by either removing two 3/8" bronze bolts in top stem nut and installing lifting device (horseshoe shaped piece of steel with two holes) over nut; or by looping a cable or nylon rope around these bolts. **Be sure lifting device is secure before removing piston.** In 4" and 6" valves, a threaded eyebolt should be screwed in the indicator rod hole.

Inspect both main bushing (Part No. 14) and bottom cylinder (Part No. 23) for mineral build-up or scoring. Smooth with emery or replace if necessary. Inspect seat ring for damage. Repair as necessary.

Secure main piston on a pipe threading stand (or lay piston on floor on rags or a similar cushioning material). Loosen top stem nut (Part No. 15) which holds the cup plate assembly. Remove cup plate bolts, nuts and copper washers on 8" cups and larger. Replace the leather cups (one faces up, one faces down). Re-install with new packings in the reverse order as outlined above.

Caution - The clamping bolts should be tight so that the packings are held securely and no leak occurs. Do not over-tighten so that the packing is deformed, however. All cup packings are impregnated with lubricants so that no external lubrication is necessary or desirable.

To replace the seat packing, it is necessary to determine if the valve is constructed with a "sliding" or a "flat" type seat. The sliding type seat has the seal or seat packing clamped in the valve body underneath the iron wall that separates the inlet and outlet valve chambers. It consists of a flanged packing held in place by a split bronze seat support ring. The lip of the packing "looks down" and care should be taken that the packing is concentric with the valve bore before the clamping bolts are tightened. In the "flat" type seat, the seat packing is located on the valve piston, where it is clamped between two plates and held by a stem nut (Part No. 7). Removal of this nut allows the plates to be separated and the packing replaced.

Replacement of the bottom cups (Part No. 5) is accomplished by removing the bottom stem lock nut (Part No. 6) and the flanged bottom guide nut (Part No. 3). Install the seals with the lip of both cups "looking up". Again, when re-assembling, be careful not to over tighten so that the cups are deformed.

Re-insert the piston being careful not to crimp the lower main cup when it enters the main bushing. The piston should move freely and drop of its own weight.

Replace the top cap and control piping (being sure to thread in the indicator rod), then restore water pressure. Be sure to open the discharge isolation valve first so that high inlet pressure is not trapped against a closed outlet valve.

All replaceable packings and gaskets are stock items and may be ordered as a repair kit for valve serial number _____. They are available for regular UPS delivery or next day service.

All spare parts are available from: Ross Valve Mfg. Co., Inc., 6 Oakwood Avenue, Troy, New York, 12180
Phone: (518) 274-0961, Fax: (518) 274-0210

ROSS VALVE Mfg. Co., Inc.

6 OAKWOOD AVENUE - P.O. BOX 595 - TROY, NEW YORK, 12181 - TEL. (518) 274 0961

GLOBE VALVE & PISTON ASSEMBLY
WITH FLAT SEAT & PLAIN PACKING SUPPORT

Piston Assembly

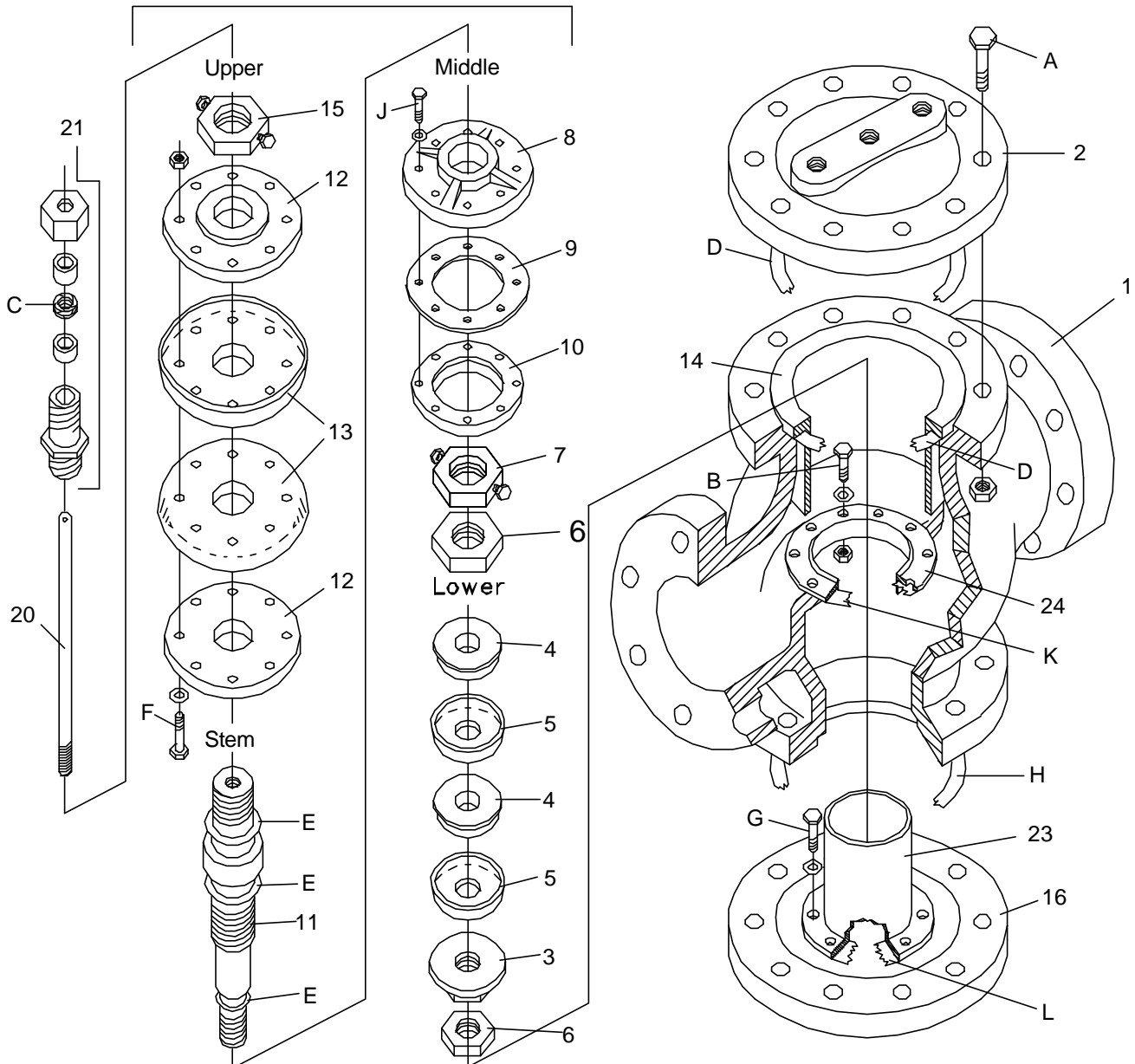

PART	DESCRIPTION	QUANTITY
1	SHELL	1
2	TOP CAP	1
3	BOTTOM STEM GUIDE NUT	1
4	PISTON CUP FOLLOWERS (SET OF 2)	1
*5	PISTON CUP PACKING	2
6	BOTTOM STEM LOCK NUT	2
7	STEM NUT W/ SET SCREWS	1
8	SEAT DISC	1
*9	SEAT PACKING	1
10	SEAT PACKING SUPPORT	1
11	STEM	1
12	MAIN CUP PLATES (SET OF 2)	1
*13	MAIN CUP PACKING	2
14	MAIN BUSHING	1
15	UPPER STEM NUT W/ SET SCREWS	1
16	BOTTOM CAP	1

PART	DESCRIPTION	QUANTITY
*20	INDICATOR ROD	1
21	INDICATOR STUFFING BOX	1
23	BOTTOM CAP CYLINDER	1
24	SEAT RING	1
A	BOLT & NUT - TOP & BOTTOM CAP	VARY
B	BOLT, NUT & WASHER - SEAT RING	VARY
*C	PACKING - INDICATOR STUFFING BOX	1 SET
*D	GASKET - TOP CAP & MAIN BUSHING	2
*E	GASKET - STEM	3
F	BOLT, NUT & WASHER - CUP PLATES	VARY
G	BOLT & WASHER - BOTTOM CAP CYLINDER	VARY
H	GASKET - BOTTOM CAP	1
J	BOLT, NUT & WASHER - SEAT DISC	VARY
K	GASKET - SEAT RING	1
L	GASKET - BOTTOM CAP CYLINDER	1

* INDICATES WHICH ITEMS COME IN THE STANDARD VALVE REPAIR KIT.