

RARGC Steel Shoot Out TRIAL
June 20th 10am

What is Steel Shoot Out? It is a series of steel targets that are set in stages. A stage is a series of 5 targets arranged in different orders. It is a timed event. So the faster you can shoot each target (you must shoot every one) the better your score will be. It may only take you one bullet per target, but it may take you many more.

When arriving at Event, Do NOT have your ammo/magazines in your case/bag/holster where your firearm is at. Pistols/revolvers must be left in case/bag/holster until competitor is on the firing line or at the safety station. You may load your magazines anywhere, but you will only be allowed to handle your firearm when on firing line or at a safety station. The safety station table will be set up in the south-east corner in the pistol range. It is used for cleaning or handling your firearm. NO ammo or magazines are allowed at the safety station.

A stage consists of 5 targets, and you will shoot each stage 5 times. We are planning on having 6 different stages. So at minimum you will need 150 rounds of ammo, but I would recommend bring 300.

Everyone who is participating will be asked to help paint targets and help set up stages.

This event is only for club Members and their children who have shot 4-H .22 pistol or have had Hunt Safe.

There will be no cost for this trial run.

Everyone on the range (inside the fence) must be wearing eye and ear protection.

We will have two stages set up at a time. You can shoot them in any order. Once all the shooters are done with them. We will set up the next two and then last two. We are planning on 6 stages.

When it is your squad's turn at a stage, have all your equipment ready. This means having your pistol cased with OBI inserted or holstered, magazines loaded, eye and ear protection on and any other shooting equipment on hand. No firearm may be loaded before shooter is on firing line. Determine what order the competitors will shoot the stage. Hand your score card to the score keeper. Then the first shooter will enter the shooting box when the Range Officer tells them to step forward.

The stages we will be using are listed below.

APPENDIX E1 – Stage Diagrams

E1.1 – Five to Go

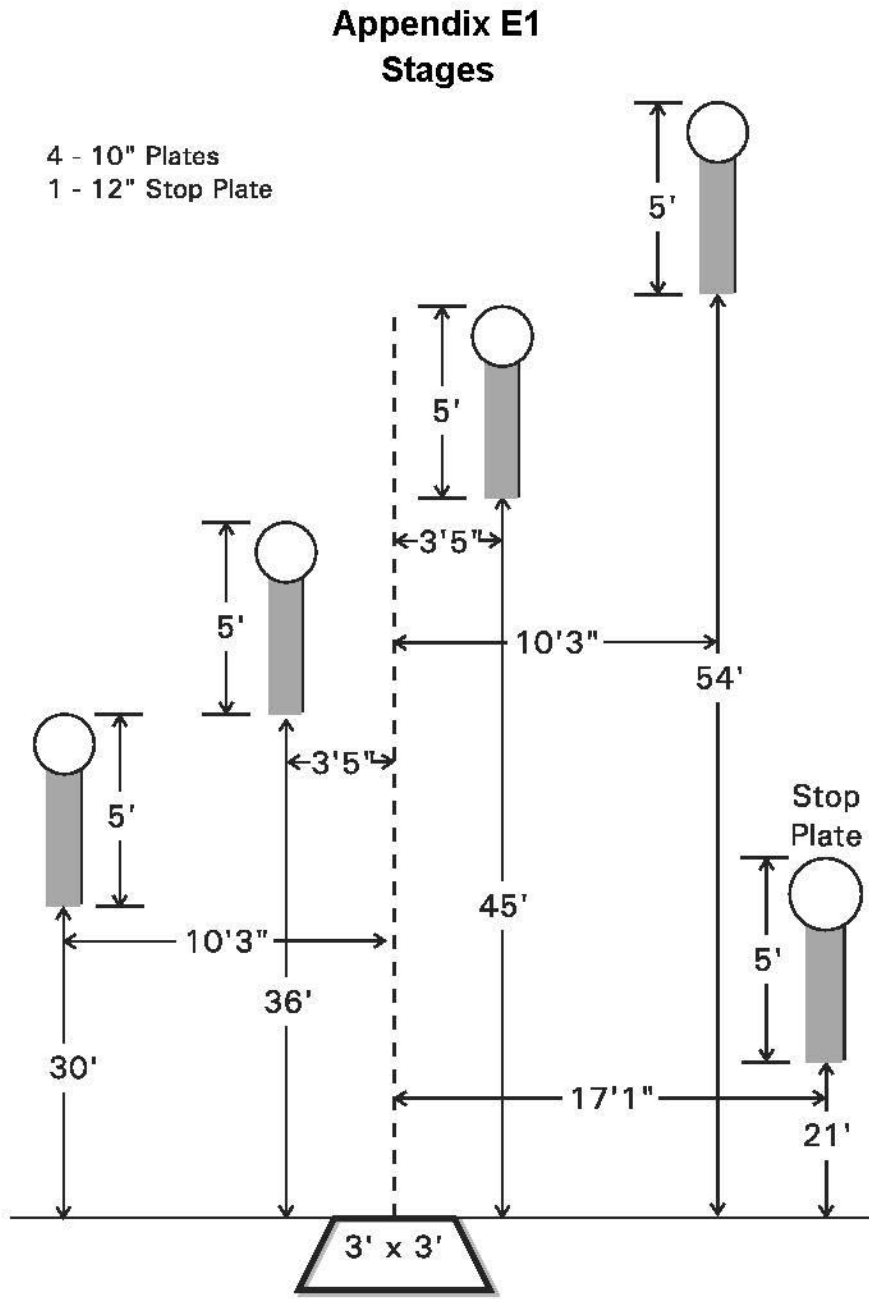

Five To Go

Best 4 of 5 runs

E1.3 – Smoke & Hope

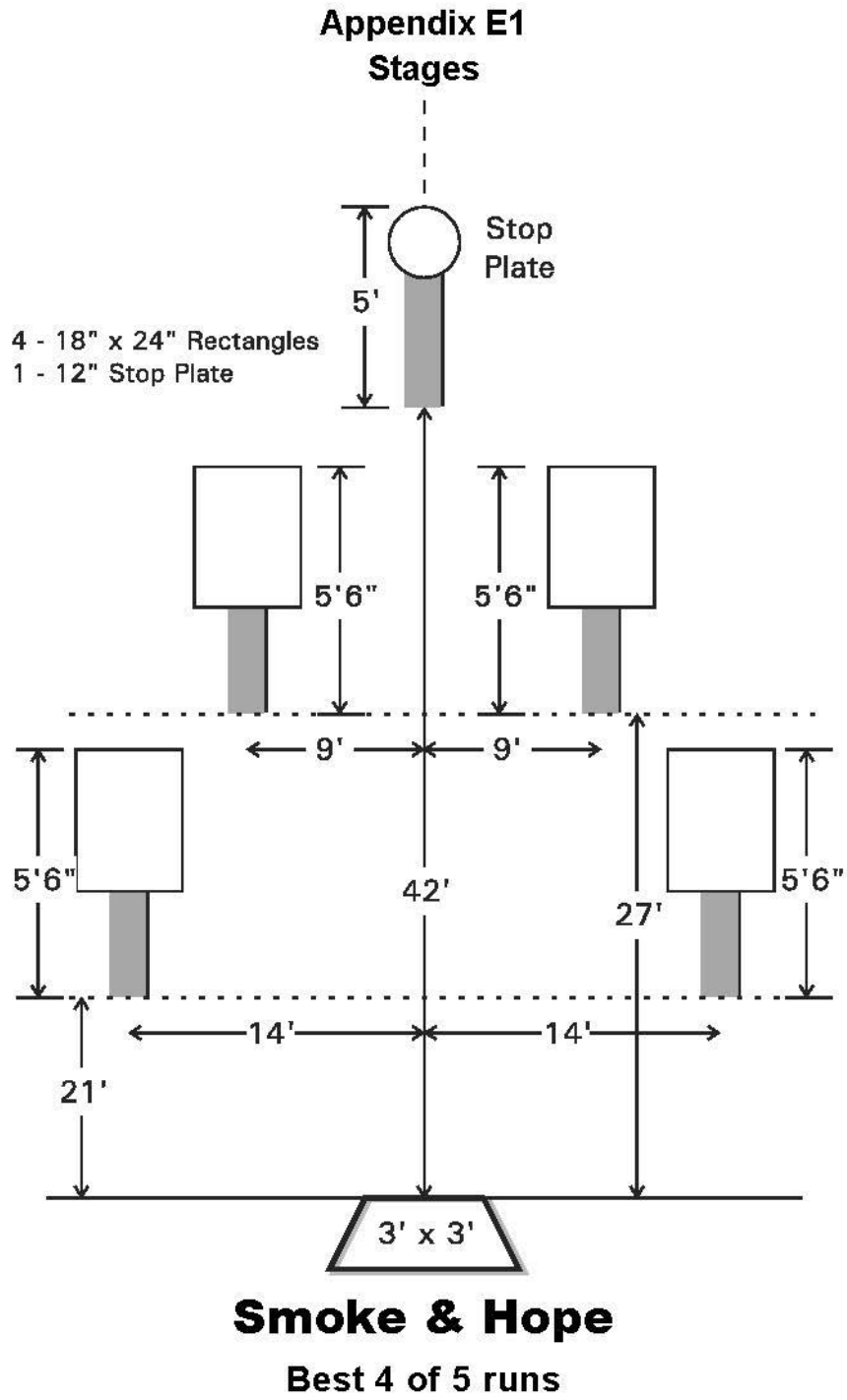

E1.2 – Showdown

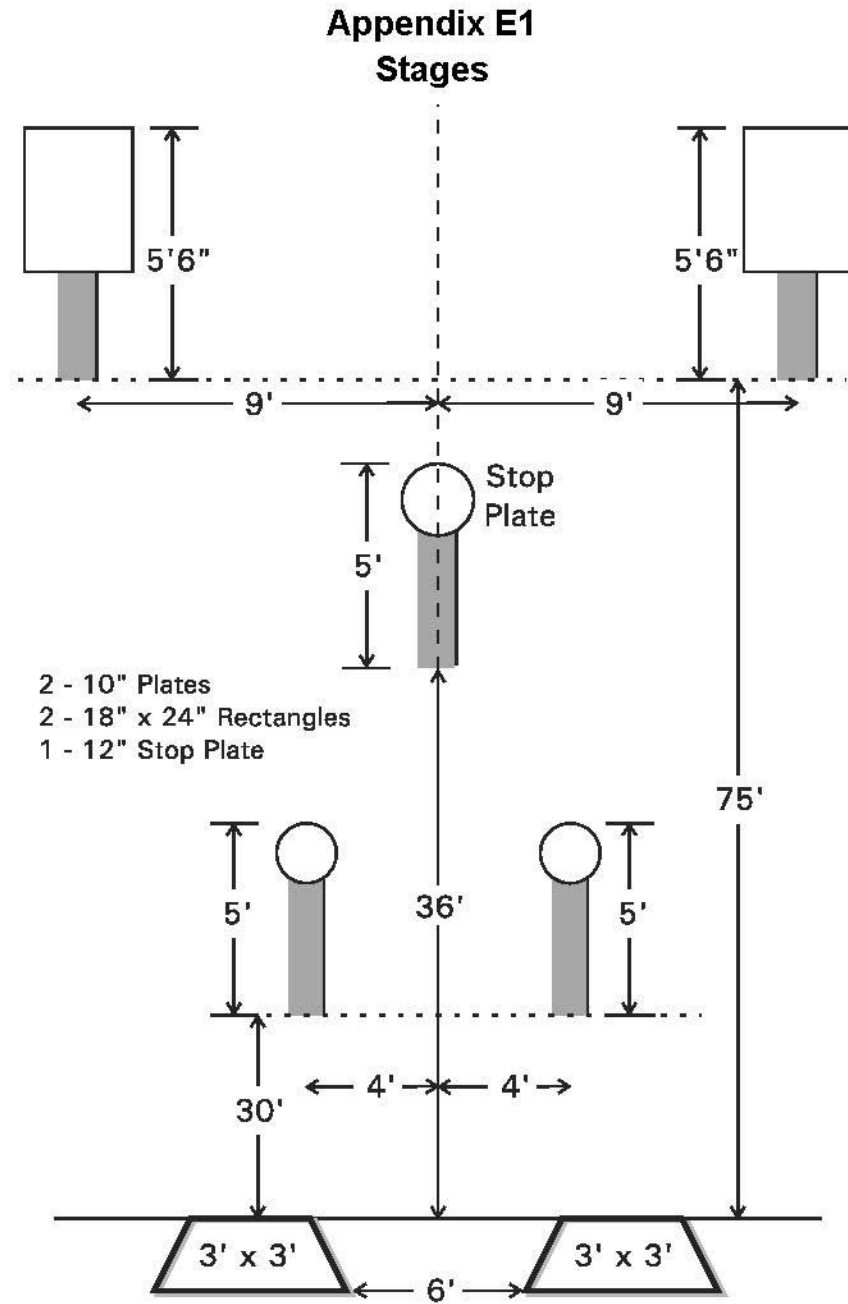

E1.4 – Pendulum

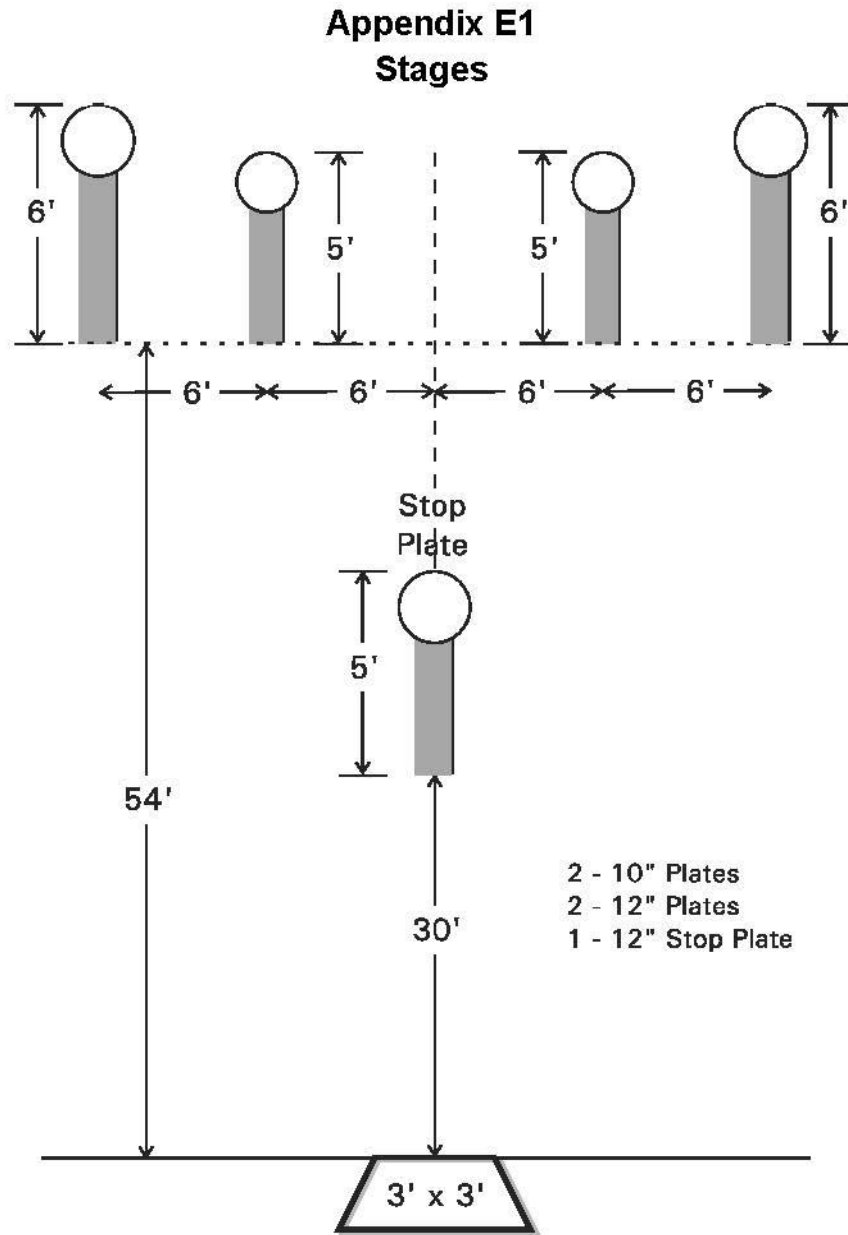

Pendulum
Best 4 of 5 runs

E1.5 – Outer Limits

**Appendix E1
Stages**

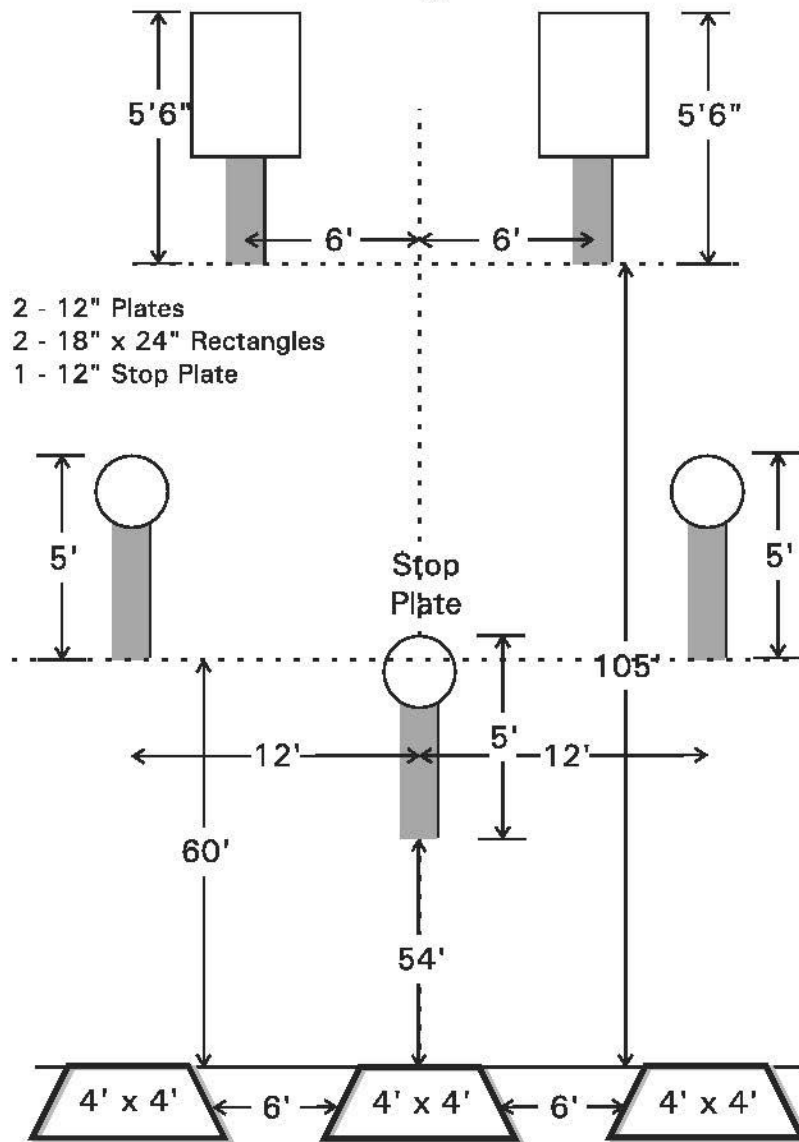

Outer Limits
Best 3 of 4 runs

Appendix E1 Stages

- 1 - 10" Plate
- 1 - 12" Plate
- 2 - 18" x 24" Rectangles
- 1 - 12" Stop Plate

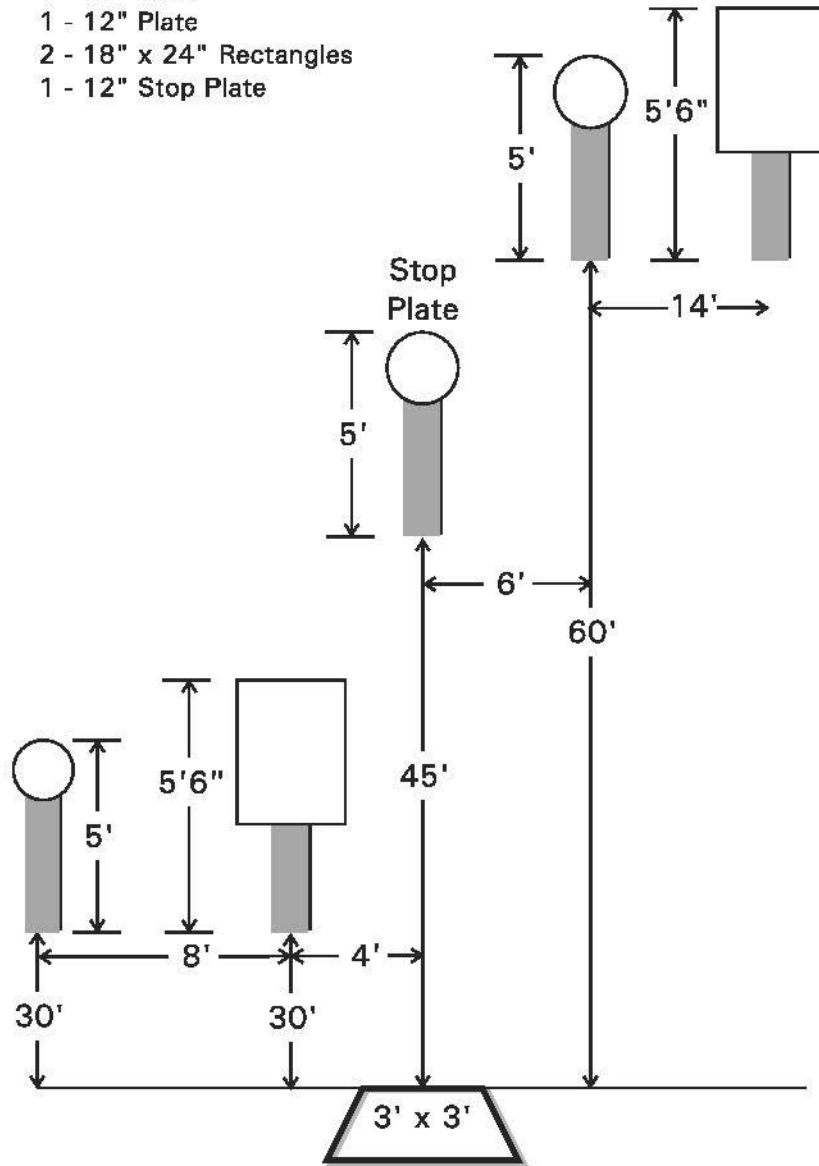

Accelerator Best 4 of 5 runs