

INSTALLATION, OPERATION & MAINTENANCE MANUAL

Four Post Surface Mounted Lift/Platform Lube Rack System

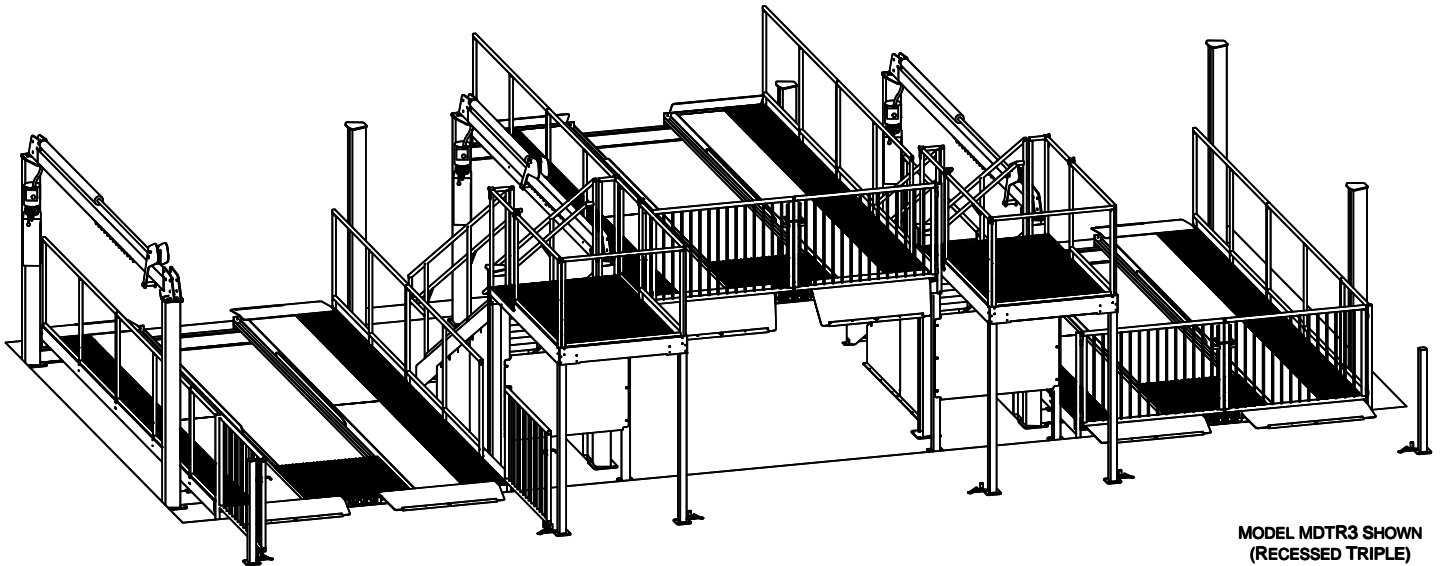

MODEL MDTR3 SHOWN
(RECESSED TRIPLE)

Model MDT

Modular Drive Thru
(12,000 lb Capacity)

200 Cabel Street, P.O. Box 3944 Louisville, Kentucky 40201-3944
Email: sales@challengerlifts.com Web site: www.challengerlifts.com

Office 800-648-5438 / 502-625-0700 Fax 502-587-1933

**IMPORTANT: READ THIS MANUAL COMPLETELY BEFORE
INSTALLING or OPERATING LIFT**

GENERAL SPECIFICATIONS: FOR 2 LIFT INSTALLATION

MODELS: MDTR2 & MDTN2 (MDT [RECESSED OR NON-RECESSED] [NUMBER OF LIFTS])

SPECIFICATIONS	MDTR	MDTN
Length Overall	26'-10 1/2"	32'-3 1/2"
Recessed Pit Length (fore-&-aft)	20'-8"	N/A
Recessed Pit Depth	7"	N/A
Lift Centerline to Lift Centerline	17'-4" (MDT_2 ONLY)	
Height of Runways	9 1/2"	
Rise Height Of Runways	79"	
Height Of Platform Grating	83"	
Width of Runways	22"	
Width Between Runways	44"	
Drive-Thru Width Between Rails	122 1/2"	
Lifting Capacity	12,000 lbs.	
Speed of Rise	35 Seconds (approximate)	
Standard 4hp, 208-230V, 60Hz, 1 Phase*	35 Seconds (approximate)	

* Optional 3 phase, 50/60Hz, 208, 230 or 460V available.

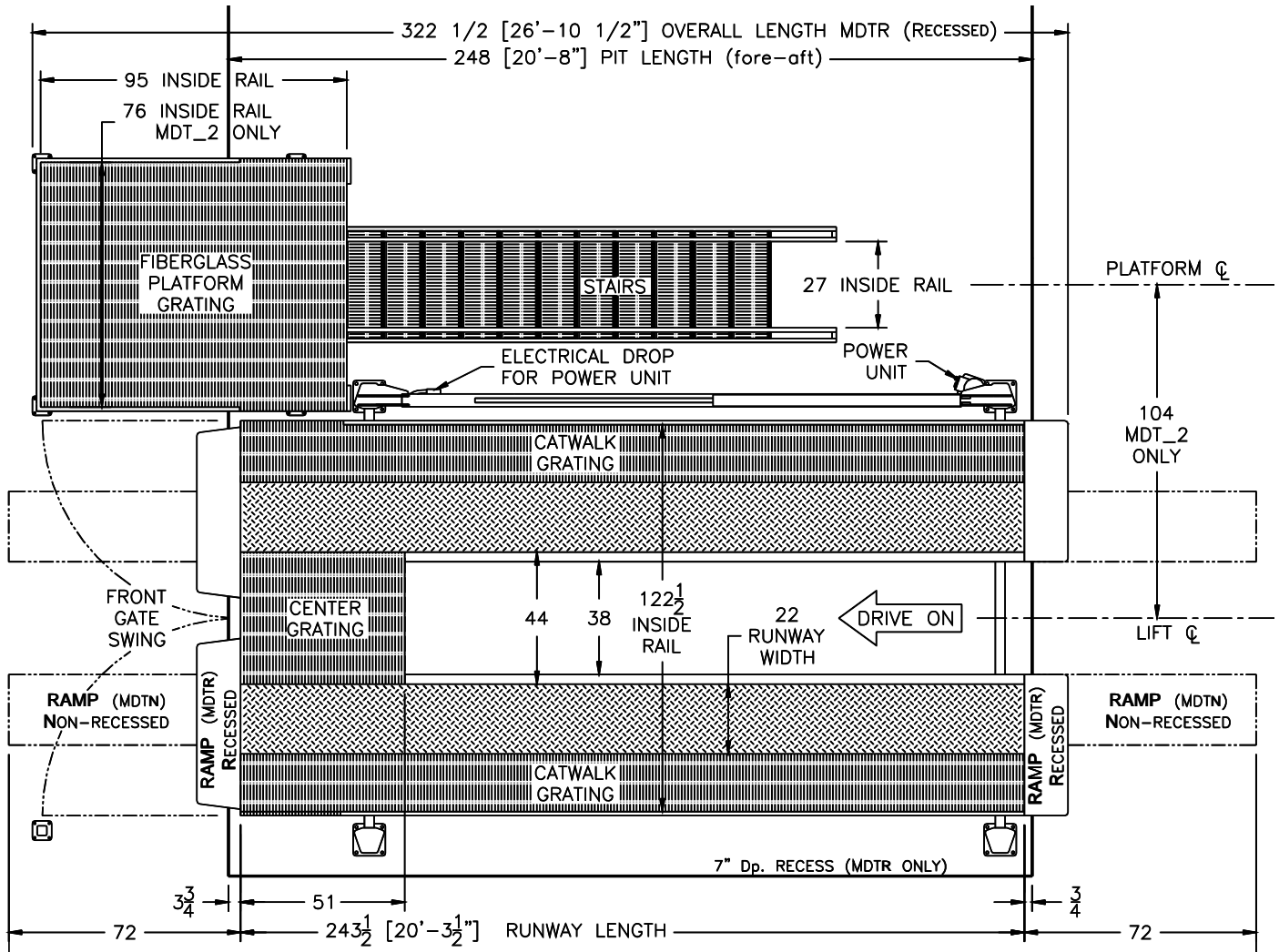

Fig 1A – General Specifications MDT_2 ONLY

GENERAL SPECIFICATIONS: FOR 3 LIFT & 4 LIFT INSTALLATION

MODELS: MDTR3, MDTN3, MDTR4, & MDTN4 (MDT [RECESSED OR NON-RECESSED] [# OF LIFTS])

SPECIFICATIONS	MDTR	MDTN
Length Overall	26'-10 1/2"	32'-3 1/2"
Recessed Pit Length (fore-&-aft)	20'-8"	N/A
Recessed Pit Depth	7"	N/A
Lift Centerline to Lift Centerline	15'-4" (MDT_3 & 4 ONLY)	
Height of Runways	9 1/2"	
Rise Height Of Runways	79"	
Height Of Platform Grating	83"	
Width of Runways	22"	
Width Between Runways	44"	
Drive-Thru Width Between Rails	122 1/2"	
Lifting Capacity	12,000 lbs.	
Speed of Rise	35 Seconds (approximate)	
Standard 4hp, 208-230V, 60Hz, 1 Phase*	35 Seconds (approximate)	

* Optional 3 phase, 50/60Hz, 208, 230 or 460V available.

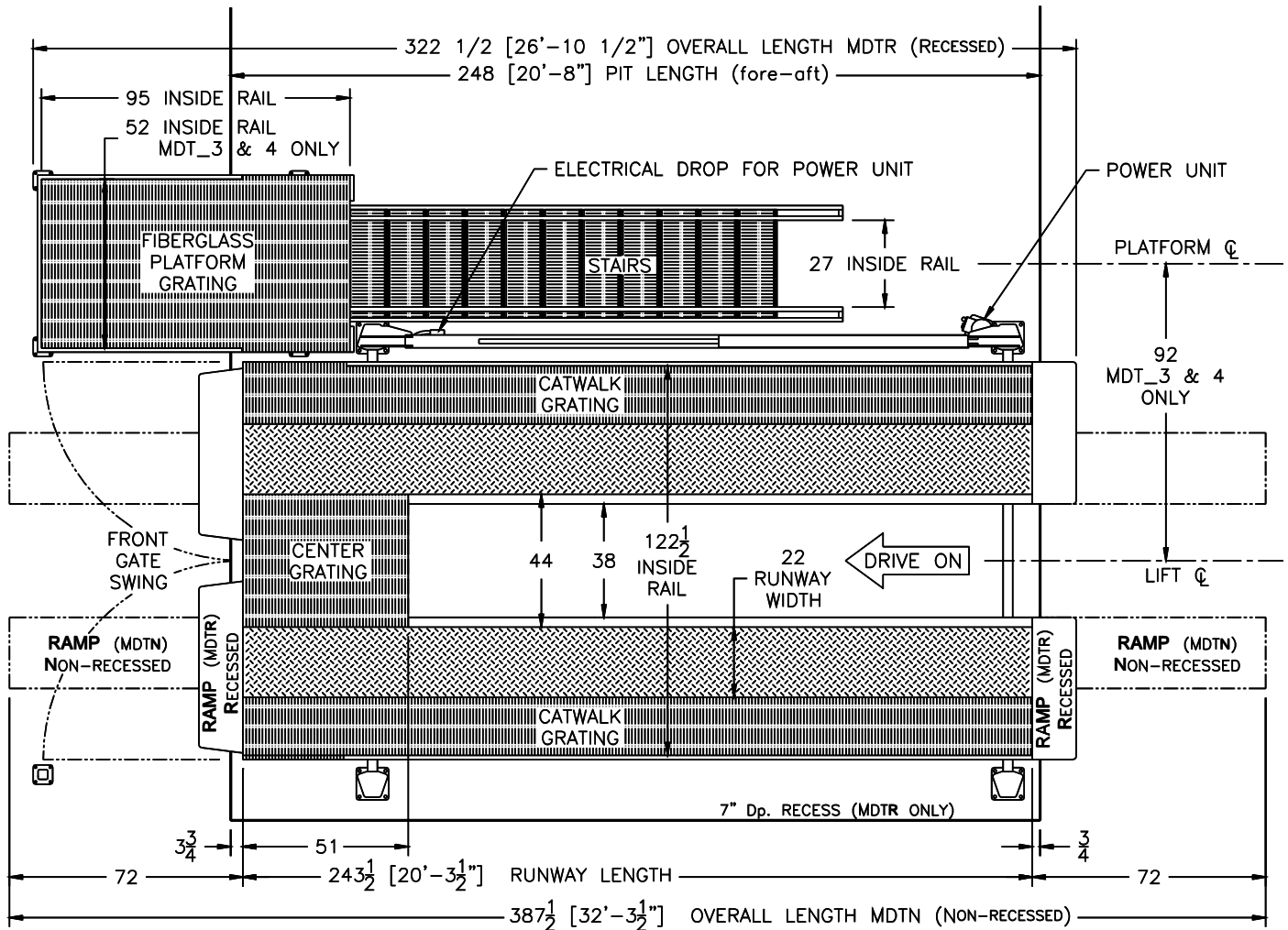

Fig 1B – General Specifications

Model MDT Lube Rack System
Installation, Operation and Maintenance

VERTICAL CLEARANCE

Check the height of the area where the lift is to be installed. Clearance should be calculated based on the full raised height of the lift.



Failure by purchaser to provide adequate clearance could result in unsatisfactory lift performance, property damage, or personal injury.

FLOORING

Be certain you have the proper concrete floor to properly handle the loaded lift. Floor should be in generally good condition with no large cracks, spalling or deterioration.

Minimum requirements for concrete are 4 inches minimum depth, with steel reinforcement, 3500 psi, cured for 28 days per local commercial practice. The four lift column base plates must rest on the same plane with each other (within 1/4" side-to-side, 1/2" front-to-rear). Supplied shims and anchors may be used for a maximum of 1/2". Steel 3/4" flat washers and grout may be used along with longer anchors to shim 1/2" or more. No anchors should be installed within 8 inches of any crack, edge, or expansion joint. If these conditions cannot be met, pads may be poured to accommodate the lift.

Check with local building inspectors and/or permits office for any special instructions or approvals required for your installation.



Failure by purchaser to provide the recommended mounting surface could result in unsatisfactory lift performance, property damage, or personal injury.

ELECTRICAL REQUIREMENTS

For lift installation and operation with a 4HP single phase power unit, it is necessary to have a dedicated circuit with a double pole 30 amp circuit breaker or time delay fuse.

SAFETY NOTICES AND DECALS

For your safety, and the safety of others, read and understand all of the safety notices and decals included here.

READ ENTIRE MANUAL BEFORE ASSEMBLING, INSTALLING, OPERATING, OR SERVICING THIS EQUIPMENT.

PROPER MAINTENANCE AND INSPECTION IS NECESSARY FOR SAFE OPERATION.

DO NOT OPERATE A DAMAGED LIFT.

Safety decals similar to those shown here are found on a properly installed lift. Be sure that all safety decals have been correctly installed on the Power Unit reservoir. Verify that all authorized operators know the location of these decals and fully understand their meaning. Replace worn, faded, or damaged decals promptly.



Do not attempt to raise a vehicle on the lift until the lift has been correctly installed and adjusted as described in this manual.

<p>SAFETY INSTRUCTIONS</p> <p>Read operating and safety manuals before using lift.</p>	<p>SAFETY INSTRUCTIONS</p> <p>Proper maintenance and inspection is necessary for safe operation.</p>	<p>WARNING</p> <p>Clear area if vehicle is in danger of falling.</p>	<p>WARNING</p> <p>Remain clear of lift when raising or lowering vehicle.</p>
<p>SAFETY INSTRUCTIONS</p> <p>Do not operate a damaged lift.</p>	<p>The messages and pictographs shown are generic in nature and are meant to generally represent hazards common to all automotive lifts regardless of specific style.</p> <p>Funding for the development and validation of these labels was provided by the Automotive Lift Institute, PO Box 33116 Indianatic, FL, 32903.</p> <p>They are protected by copyright. Set of labels may be obtained from ALI or its member companies.</p> <p>© 1992 by ALL, Inc. ALI/WL2004</p>		
<p>CAUTION</p> <p>Lift to be used by trained operator ONLY.</p>	<p>CAUTION</p> <p>Authorized personnel only in lift area.</p>	<p>WARNING</p> <p>Do not override self-closing lift controls.</p>	<p>WARNING</p> <p>Check wheel to prevent vehicle movement.</p>
<p>The messages and pictographs shown are generic in nature and are meant to generally represent hazards common to all automotive lifts regardless of specific style.</p> <p>Funding for the development and validation of these labels was provided by the Automotive Lift Institute, PO Box 33116 Indianatic, FL, 32903.</p> <p>They are protected by copyright. Set of labels may be obtained from ALI or its member companies.</p> <p>© 1992 by ALL, Inc. ALI/WL2004</p>			

RECEIVING

The shipment should be thoroughly inspected as soon as it is received. The signed bill of lading is acknowledgement by the carrier of receipt in good condition of shipment covered by our invoice.

If any of the goods called for on this bill of lading are shorted or damaged, do not accept them until the carrier makes a notation on the freight bill of the shorted or damaged goods. Do this for your own protection.

NOTIFY **Challenger Lifts** AT ONCE if any hidden loss or damage is discovered after receipt.

IT IS DIFFICULT TO COLLECT FOR LOSS OR DAMAGE AFTER YOU HAVE GIVEN THE CARRIER A CLEAR RECEIPT.

File your claim with **Challenger Lifts** promptly. Support your claim with copies of the bill of lading, freight bill, and photographs, if available.

ABOUT THIS MANUAL

THIS INSTALLATION MANUAL INCLUDES INSTRUCTIONS FOR INSTALLING BOTH THE MDTR AND MDTN AS WELL AS FOR DUAL, TRIPLE, AND QUAD LIFT PACKAGES.

- MDTR – MODULAR DRIVE THRU RECESSED (THE ENTIRE AREA UNDER THE LIFTS IS RECESSED 7" BELOW GRADE)
- MDTN – MODULAR DRIVE THRU NON-RECESSED

DIFFERENCES BETWEEN THESE TWO INSTALLATIONS:

1. THE FRONT PLATFORM LEGS OF THE MDTR ARE 7" SHORTER THAN THE REAR LEGS.
2. THE RAMPS OF THE MDTR ARE SHORT (14") WHILE THOSE OF THE MDTN ARE LONG (6').
3. THE LATCHES USED TO HOLD THE FRONT GATES OPEN FOR THE MDTN ARE TALLER AND INCLUDE A SUPPORT CHANNEL.

DUAL, TRIPLE, AND QUAD LIFT PACKAGES

- MDTN_{OR}R2 – (2) LIFTS, (1) 79" WIDE PLATFORM
- MDTN_{OR}R3 – (3) LIFTS, (2) 55" WIDE PLATFORMS
- MDTN_{OR}R4 – (4) LIFTS, (3) 55" WIDE PLATFORMS

FIGURES 1A, 2A, 3A, & 4A AND THEIR CORRESPONDING TABLES ARE TO BE USED FOR DUAL LIFT INSTALLATIONS. FIGURES 1B, 2B, 3B, & 4B AND THEIR CORRESPONDING TABLES ARE TO BE USED FOR TRIPLE OR QUAD LIFT INSTALLATIONS.

TO AVOID CONFUSION, MARK THRU THE "B" FIGURES AND TABLES WHEN INSTALLING A DUAL, OR MARK THRU THE "A" FIGURES AND TABLES WHEN INSTALLING A TRIPLE OR QUAD.

COMPONENT PACKING LIST

- MDTR2 installation see **Table 2A and Fig 2A**
- MDTR3 & 4 installation see **Table 2B and Fig 2B**
- MDTN2 installation see **Table 2B and Fig 2B**
- MDTN3 & 4 installation see **Table 2B and Fig 2B**

INSTALLATION

IMPORTANT: Always wear safety glasses while installing lift.

COMPONENT WEIGHTS

- a. Each **Runway** weighs approximately 1200 lbs.
- b. Each **Cylinder Beam** weighs approximately 500 lbs. and must be raised to rest on top of 7 1/2 ft. legs
- c. The **Platform Frame** weighs approximately 200 lbs. and must be raised to rest on top of 7 ft. columns

TOOLS (MINIMUM REQUIRED)

- a. Banding cutters
- b. Box knife
- c. Tape measure, 50ft
- d. Chalk line
- e. 4ft level
- f. 10" & 12" adjustable wrench
- g. Standard open end wrench set
- h. Needle nose pliers
- i. Thread tape sealant (for air line)
- j. Hammer drill with 3/4", 1/2", & 1/4" diameter carbide tipped bits
- k. 2lb hammer
- l. Torque wrench: 150 foot pounds minimum with 1 1/8" & 3/4" sockets
- m. 6 ft. Step ladder
- n. boom lift (*engine hoist*) 600 lbs. min. capacity, 9 ft. min. height
- o. Two (2) furniture type dollies – 1200 lbs. min. capacity

Model MDT Lube Rack System
Installation, Operation and Maintenance

Table 2A – Component Packing List - MDT_2 ONLY

ITEM #	QTY/ LIFT	QTY/ PLTFRM	QTY/ STORE	P/N	
1	1			44730-L	HARDWARE BOX - LIFT
2		1		44730-P	HARDWARE BOX - PLATFORM
3			1	44730-S	HARDWARE BOX - STORE
4	1			44731-R	RAMP / GATE-OPEN HARDWARE (Recessed)
				44731-N	RAMP / GATE-OPEN HARDWARE (Non-Recessed)
5	1			24081	2HP 1ph POWER UNIT
				24082	2HP 3ph POWER UNIT
				24081-4HP	4HP 1ph POWER UNIT
				24082-4HP	4HP 3ph POWER UNIT
6	1				POWER COLUMN
7	1				POWER SIDE COLUMN
8	2				IDLER COLUMN
9	1				CYLINDER BEAM - MDT
10	2				CROSS BEAM - MDT
11	1			44740-L	RUNWAY - LEFT
12	1			44740-R	RUNWAY - RIGHT
13	2			44761	FRONT RAMP (Recessed)
14				44770	RAMP ASSEMBLY (Non-Recessed)
15	2			44766	REAR RAMP (Recessed)
16				44770	RAMP ASSEMBLY (Non-Recessed)
17		1		44800	STAIRS
18		1		44805-L	SHORT STAIR COVER - LEFT
19		1		44805-R	SHORT STAIR COVER - RIGHT
20		1		44806-L	TALL STAIR COVER - LEFT
21		1		44806-R	TALL STAIR COVER - RIGHT
22R		1		44780W-R	PLATFORM WELD – RIGHT SIDE
22L		1		44780W-L	PLATFORM WELD – LEFT SIDE
22F		1		44780W-F	PLATFORM WELD – FRONT
22B		1		44780W-B	PLATFORM WELD – BACK
23		2		44790-T	REAR LEG - TALL (81")
24		2		44790-S	FRONT LEG - SHORT (74") (Recessed)
				44790-T	FRONT LEG - TALL (81") (Non-Recessed)
25		1		44807W	PUMP MOUNT PLATE
26	4			44811	RUNWAY RAIL (103 3/8")
27			2	44812	RUNWAY FILLER RAIL (36 1/4")
28		1		44817-L	STAIR RAIL - LEFT
29		1		4817-R	STAIR RAIL - RIGHT
30		1		44813W	PLATFORM RAIL - FRONT (75 3/4")
31		2		44814	PLATFORM RAIL - SIDE (61 5/8")
32		2		44815W	PLATFORM RAIL - BACK (20")
33		2		44816	DROP-GATE
34	1			44845-L	GATE POST - LEFT
35	1			44845-R	GATE POST - RIGHT
36	2			44850	GATE
37	2			44860	GATE LATCH w/ ROLLER
38	2			44865	LATCH HANDLE ASSEMBLY
39	1			44870	GATE-CLOSED LATCH / RUNWAY TIE BAR
40	2			44880-R	GATE-OPEN LATCH (Recessed)
41				44880-N	GATE-OPEN LATCH (Non-Recessed)
42	2			44884	LATCH SUPPORT CHANNEL (Non-Recessed ONLY)
43			2	44793	GATE-OPEN POST
44	1			44705	RUNWAY GRATING PKG - SEE FIG. 35
45		1		44706	PLATFORM GRATING PKG - SEE FIG. 35
				44704W	PLATFORM GRATING EXTENSION PKG - SEE FIG. 35
46	2			40265	WHEEL CHOCK

Model MDT Lube Rack System
Installation, Operation and Maintenance

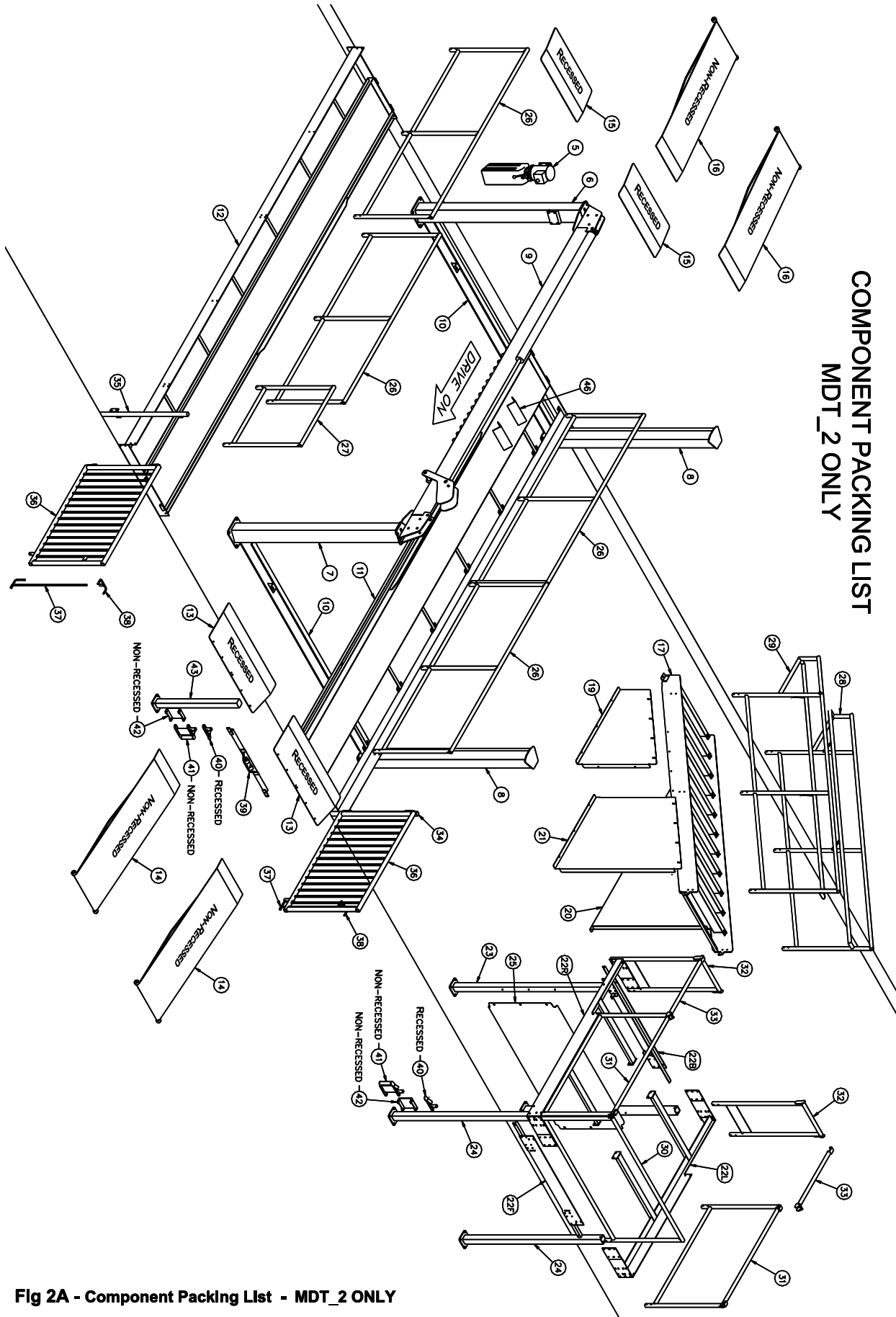

COMPONENT PACKING LIST
MDT_2 ONLY

Fig 2A - Component Packing List - MDT_2 ONLY

Model MDT Lube Rack System
Installation, Operation and Maintenance

Table 2B – Component Packing List - MDT_3 & 4 ONLY

ITEM #	QTY/ LIFT	QTY/ PLTFRM	QTY/ STORE	P/N	
1	1			44730-L	HARDWARE BOX - LIFT
2		1		44730-P	HARDWARE BOX - PLATFORM
3			1	44730-S	HARDWARE BOX - STORE
4	1			44731-R	RAMP / GATE-OPEN HARDWARE (Recessed)
				44731-N	RAMP / GATE-OPEN HARDWARE (Non-Recessed)
5	1			24081	2HP 1ph POWER UNIT
				24082	2HP 3ph POWER UNIT
				24081-4HP	4HP 1ph POWER UNIT
				24082-4HP	4HP 3ph POWER UNIT
6	1				POWER COLUMN
7	1				POWER SIDE COLUMN
8	2				IDLER COLUMN
9	1				CYLINDER BEAM - MDT
10	2				CROSS BEAM - MDT
11	1			44740-L	RUNWAY - LEFT
12	1			44740-R	RUNWAY - RIGHT
13	2			44761	FRONT RAMP (Recessed)
14				44770	RAMP ASSEMBLY (Non-Recessed)
15	2			44766	REAR RAMP (Recessed)
16				44770	RAMP ASSEMBLY (Non-Recessed)
17		1		44800	STAIRS
18		1		44805-L	SHORT STAIR COVER - LEFT
19		1		44805-R	SHORT STAIR COVER - RIGHT
20		1		44806-L	TALL STAIR COVER - LEFT
21		1		44806-R	TALL STAIR COVER - RIGHT
22		1		44780	PLATFORM
23		2		44790-T	REAR LEG - TALL (81")
24		2		44790-S	FRONT LEG - SHORT (74") (Recessed)
				44790-T	FRONT LEG - TALL (81") (Non-Recessed)
25		1		44807	PUMP MOUNT PLATE
26	4			44811	RUNWAY RAIL (103 3/8")
27			2	44812	RUNWAY FILLER RAIL (36 1/4")
28		1		44817-L	STAIR RAIL - LEFT
29		1		4817-R	STAIR RAIL - RIGHT
30		1		44813	PLATFORM RAIL - FRONT (51 3/4")
31		2		44814	PLATFORM RAIL - SIDE (61 5/8")
32		2		44815	PLATFORM RAIL - BACK (8")
33		2		44816	DROP-GATE
34	1			44845-L	GATE POST - LEFT
35	1			44845-R	GATE POST - RIGHT
36	2			44850	GATE
37	2			44860	GATE LATCH w/ ROLLER
38	2			44865	LATCH HANDLE ASSEMBLY
39	1			44870	GATE-CLOSED LATCH / RUNWAY TIE BAR
40	2			44880-R	GATE-OPEN LATCH (Recessed)
41				44880-N	GATE-OPEN LATCH (Non-Recessed)
42	2			44884	LATCH SUPPORT CHANNEL (Non-Recessed ONLY)
43			2	44793	GATE-OPEN POST
44	1			44705	RUNWAY GRATING PKG 44705 - SEE FIG. 35
45		1		44706	PLATFORM GRATING PKG 44706 - SEE FIG. 35
46	2			40265	WHEEL CHOCK

Model MDT Lube Rack System
Installation, Operation and Maintenance

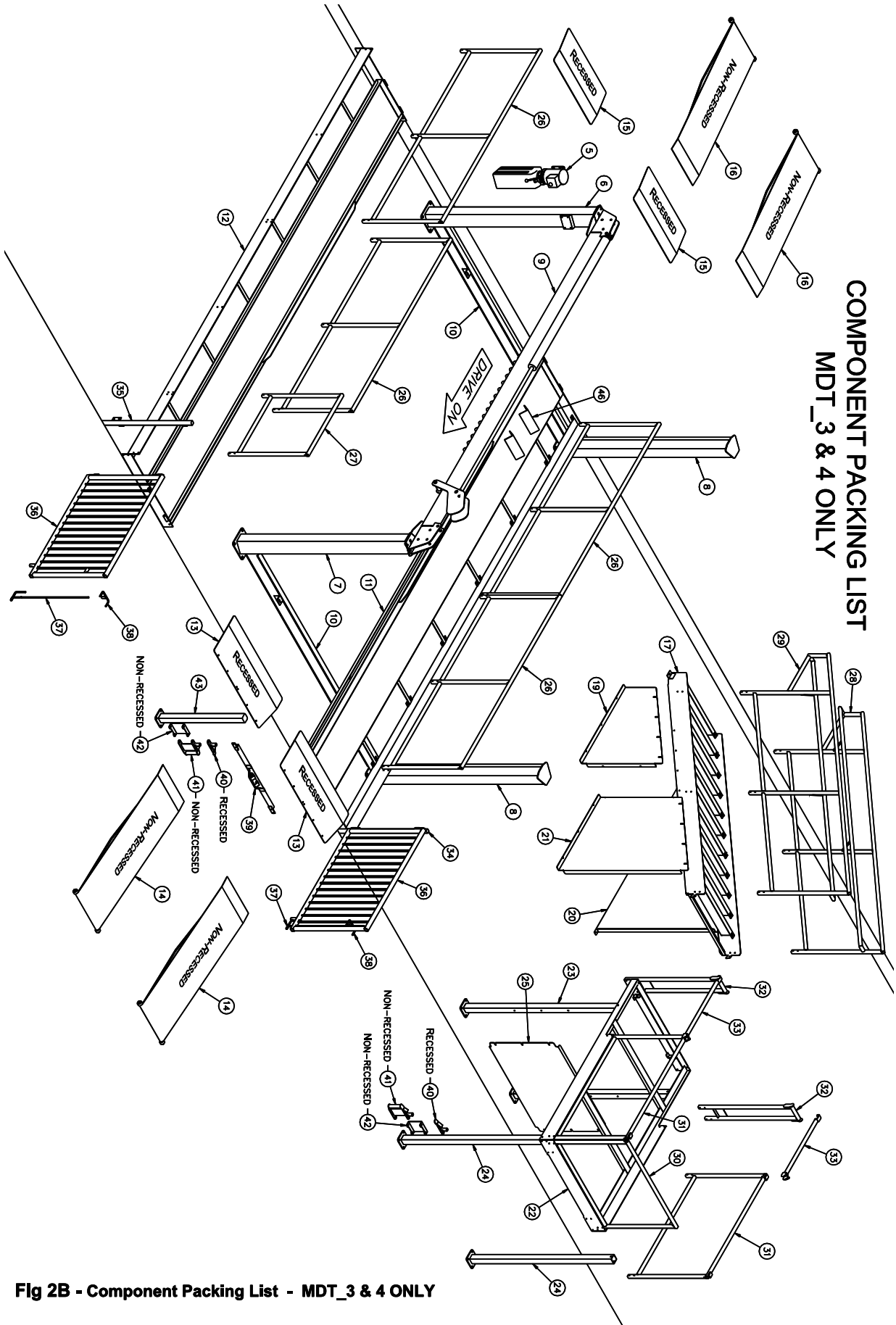

Fig 2B - Component Packing List - MDT_3 & 4 ONLY

Model MDT Lube Rack System
Installation, Operation and Maintenance

SERVICE BAY LAYOUT
MODEL MDTR2 ONLY (MODULAR DRIVE THRU RECESSED DUAL)

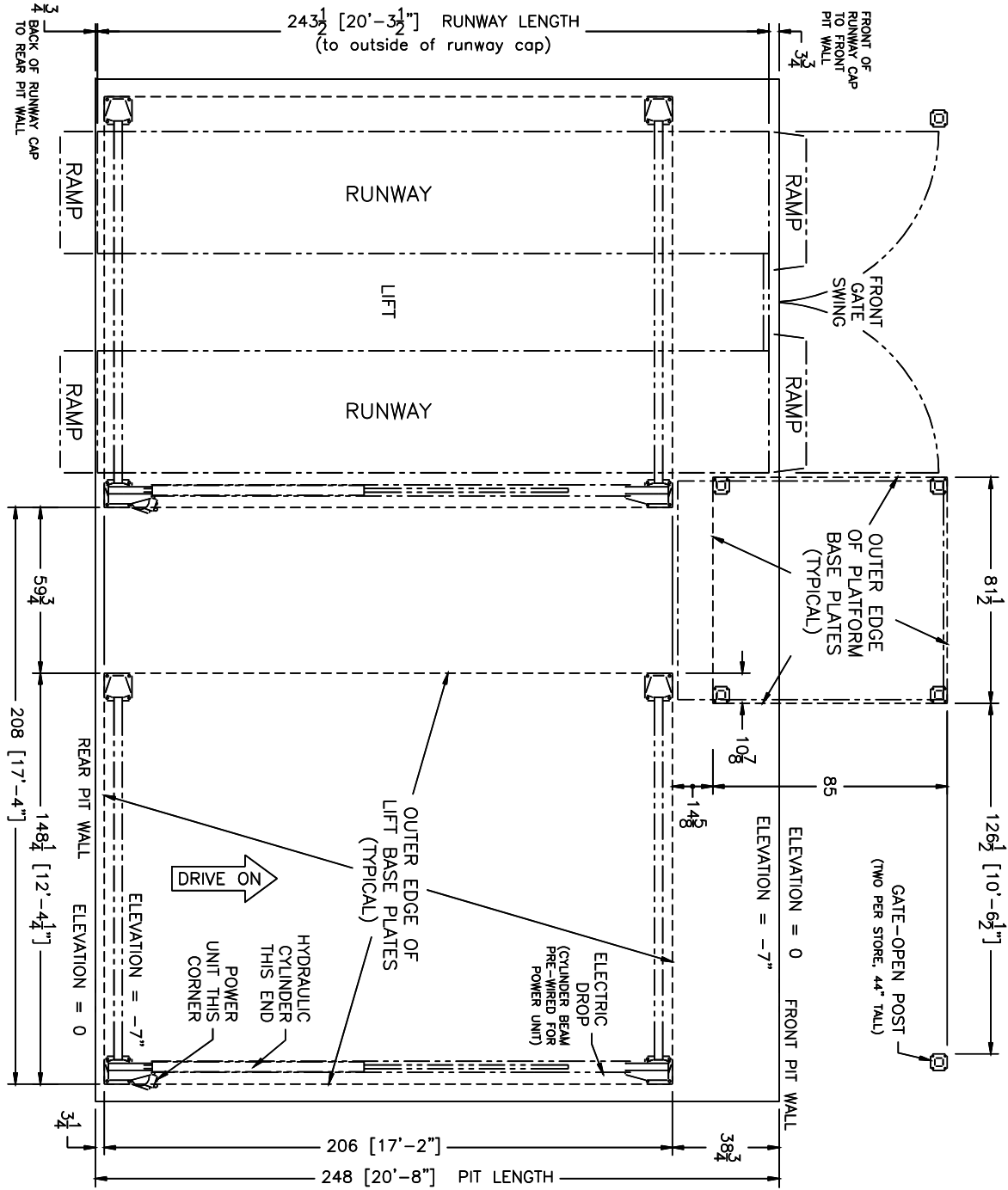
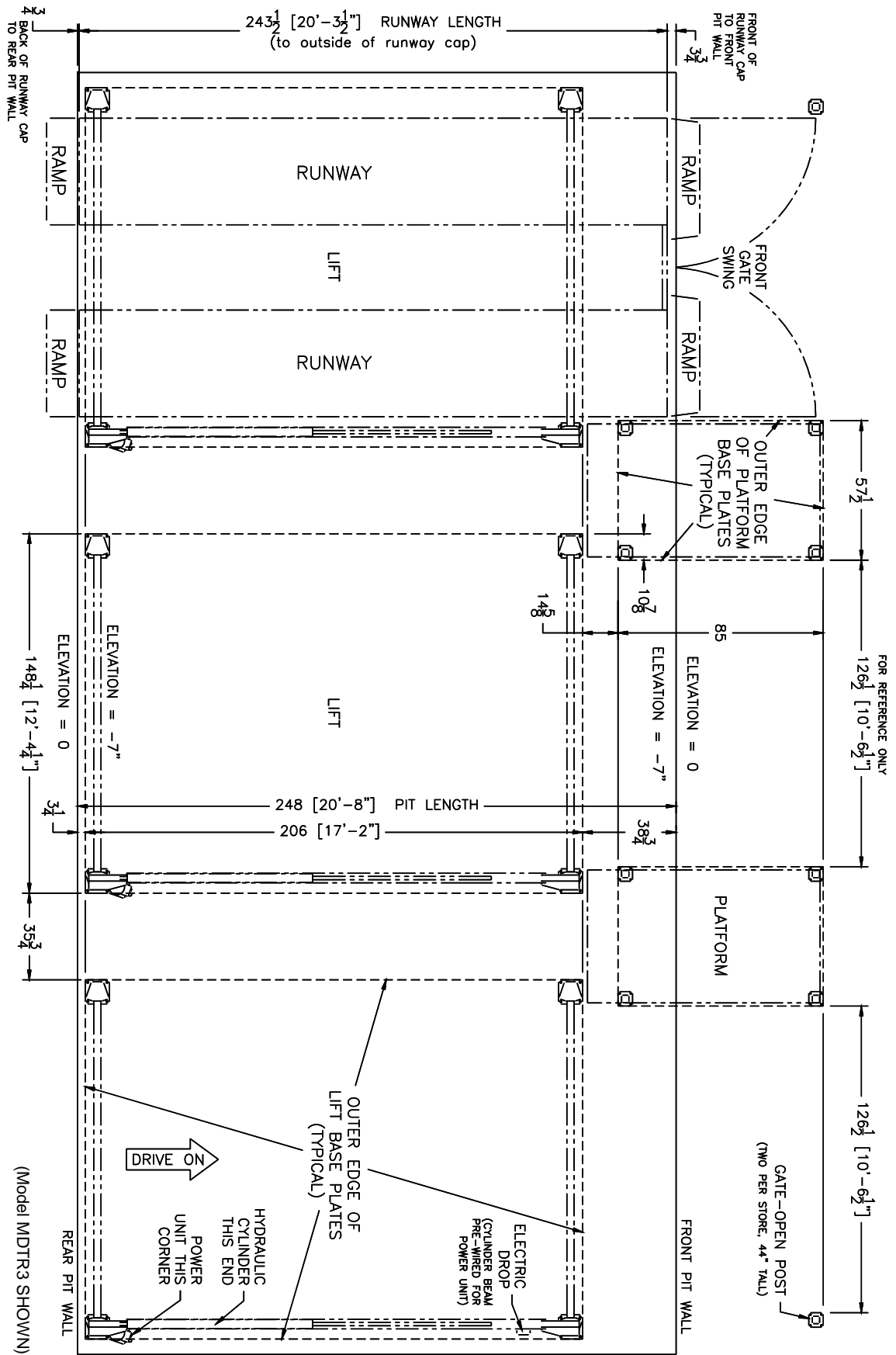

Fig 3A - Service Bay Layout (MDTR2 ONLY)

Model MDT Lube Rack System
Installation, Operation and Maintenance



SERVICE BAY LAYOUT
MODEL MDT R3 & 4 ONLY (MODULAR DRIVE THRU RECESSED TRIPLE OR QUAD)

Fig 3B - Service Bay Layout (MDTR3 & 4 ONLY)

Model MDT Lube Rack System
Installation, Operation and Maintenance

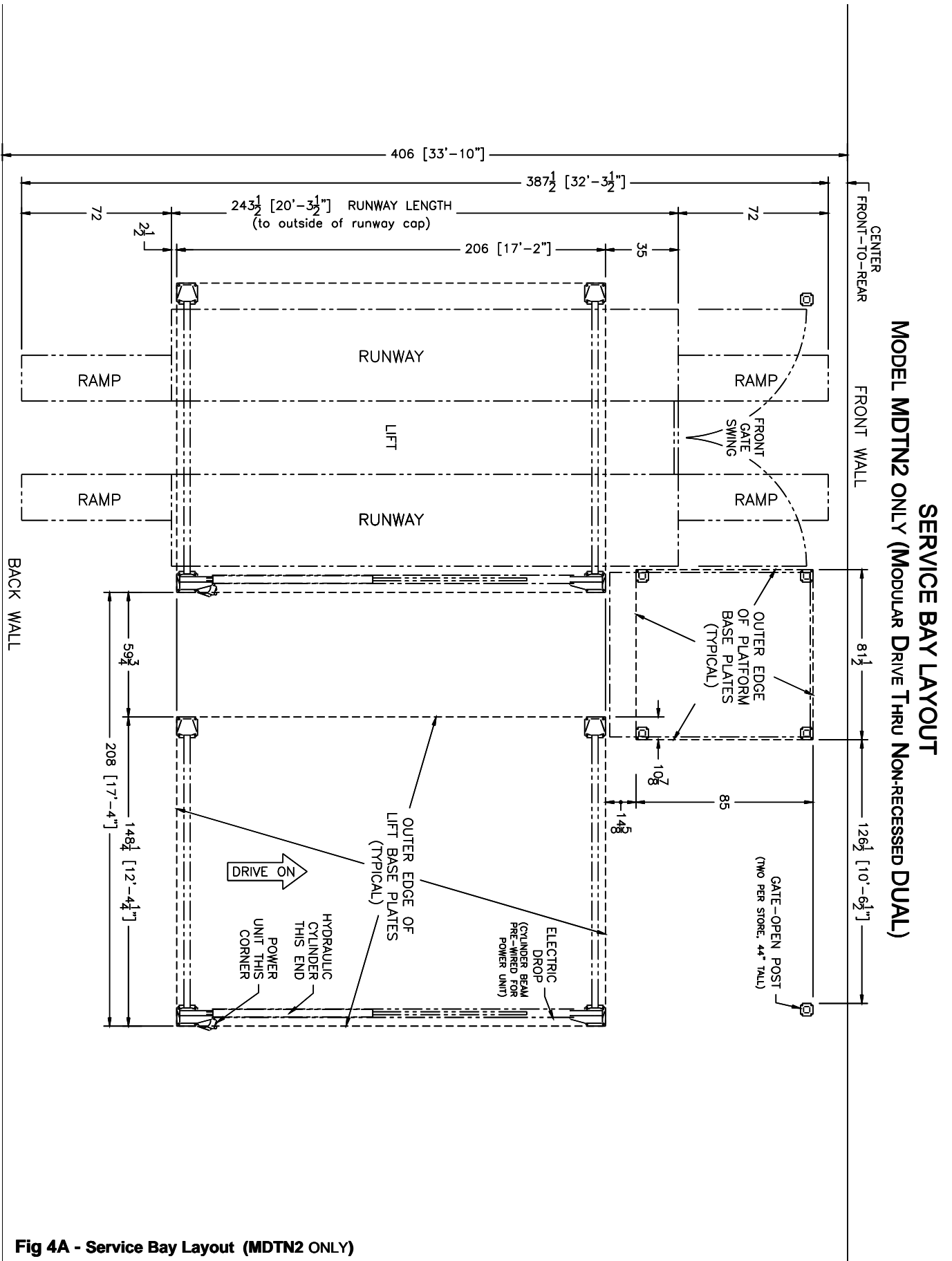
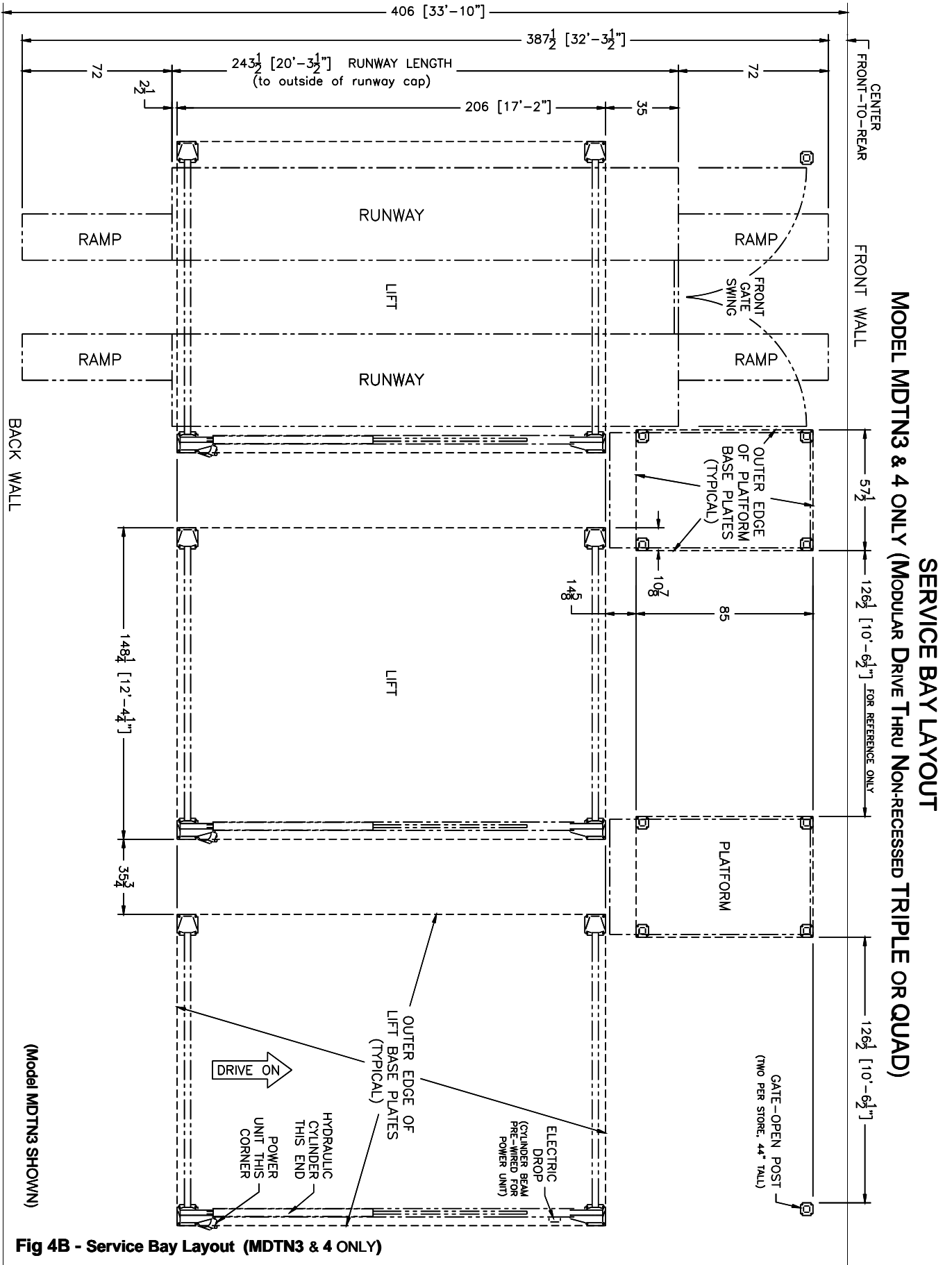

Fig 4A - Service Bay Layout (MDTN2 ONLY)

Model MDT Lube Rack System
Installation, Operation and Maintenance



Model MDT Lube Rack System
Installation, Operation and Maintenance

LAYOUT

1) Lay out the service bays according to the architect's plans and the corresponding "Service Bay Layout".

- MDTR2 installation see Fig 3A
- MDTR3 & 4 installation see Fig 3B
- MDTN2 installation see Fig 4A
- MDTN3 & 4 installation see Fig 4B

NOTE: For this multi-bay layout it is good practice to start with layout lines near the middle and work outward in both directions. This will lessen the effects of small errors.

The following instructions apply for each lift. Consider which lift to install first based on accessibility.

2) Check lift column base plate layout lines using Fig 5 below.

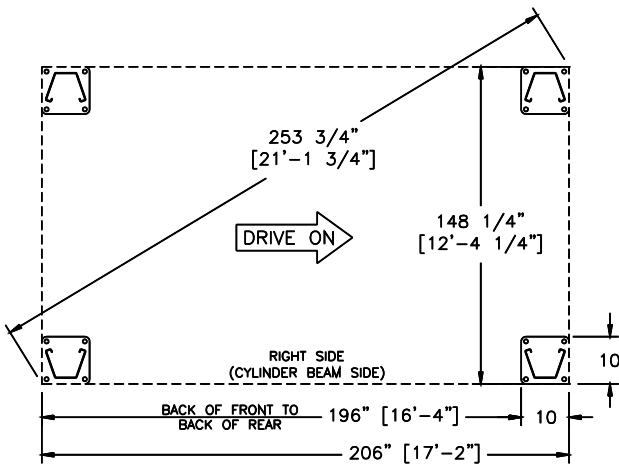

Fig 5 – Column Base Plate Layout Lines

3) Record required shimming at each column. The four lift column base plates must rest on the same plane with each other (within 1/4" side-to-side, 1/2" front-to-rear).

4) Position both right side (passenger, cylinder beam side) columns.

Note that each lift uses three (3) different column types.

- **Right-Front** has a large hole in the top plate for the lift chain to pass through and a chain lug welded to the base plate inside the column for the synchronizer chain
- **Right-Rear** is same as right-front with a power unit bracket
- **Left Side** plain (no synch. chain lug & no power unit bracket)

5) With the right side columns positioned but not anchored, measure the distance from the *back* of the **front column** base plate to the *back* of the **rear column** base plate (this is the same as measuring the center-to-center of the two columns), see Fig 5. This measurement should match (within 1/8") the center-to-center distance from the slack chain rod holes in the cylinder beam, Fig 6. If the two dimensions do not match, move the rear column (not to exceed 1/2") to make them match.

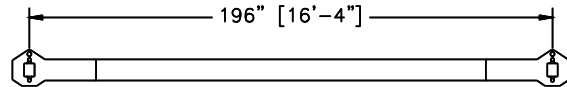

Fig 6 – Cylinder Beam Measurement

Model MDT Lube Rack System
Installation, Operation and Maintenance

ANCHORING (3/4" WEDGE ANCHORS)

- 6) Mark the exact location of the two right side columns and begin anchoring using the following procedures:
 - a) Ensure the concrete has had sufficient time to cure - 28 days minimum.
 - b) Always wear safety glasses.
 - c) Follow the drill manufacturers safety instruction.
 - d) Use only solid carbide-tipped drill bits meeting ANSI B94 tip diameter standards.
 - e) Using the column as a template, drill the anchor bolt holes perpendicular to the work surface. To assure full holding power, do no ream the hole or allow the drill to wobble.
 - f) Drill the hole at least as deep as the full length of the anchor, completely through the slab if possible.
 - g) Clean the hole, using compressed air and a wire brush or vacuum. A clean hole is necessary for proper performance.
- 7) Insert spacer shims under the base plate as recorded in **step 3** to bring the columns to the same plane (not necessarily plumb yet). Supplied shims and anchors may be used for a maximum of 1/2". Steel 3/4" flat washers and grout may be used along with longer anchors to shim greater than 1/2".
- 8) Assemble the washer and nut on the anchor bolt so that the anchor protrudes slightly beyond the nut. Use appropriately longer anchors where shims exceeds 1/2".
- 9) Drive the anchor through the lift base plate and into the hole, making sure that the nut rests solidly against the top of the base plate.
- 10) Apply 150 ft-lbs setting torque to each anchor nut.
- 11) Plumb both columns. Using a level, check both side-to-side and front to rear. Use shims provided or steel 3/4" flat washers to plumb. Tighten the anchor bolts and recheck for plumb. Adjust if necessary. Check the dimension from the back of the front column to the front of the rear column at the base plate and again at the top of the column, **Fig 7**. When the columns are parallel, these dimensions will match. Adjust front column shims to make columns parallel.

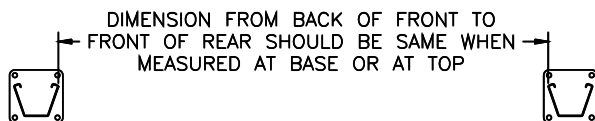

Fig 7 – Column Parallel Measurements

CYLINDER BEAM / CROSSBEAMS

- 12) Install cylinder beam with the tail end of the cylinder above the rear column and the rod extending forward.
- 13) Position crossbeams (front and rear crossbeams are identical) with the lift chain attachment block on the right and the runway mounting angle tabs extending forward, **Fig 8**.

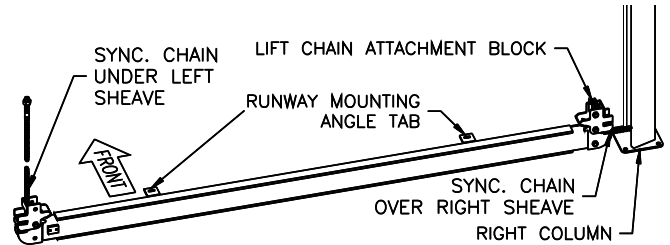

Fig 8 – Crossbeam Orientation

- 14) Route one synchronizer chain through each crossbeam, over right sheave and under left sheave. Use a master link to attach the **right** end of each synchronizer chain to the right side column base chain lug, **Fig 9**. Again, using a master link, attach the **left** end of each synchronizer chain to a threaded chain lug, **Fig 10**.

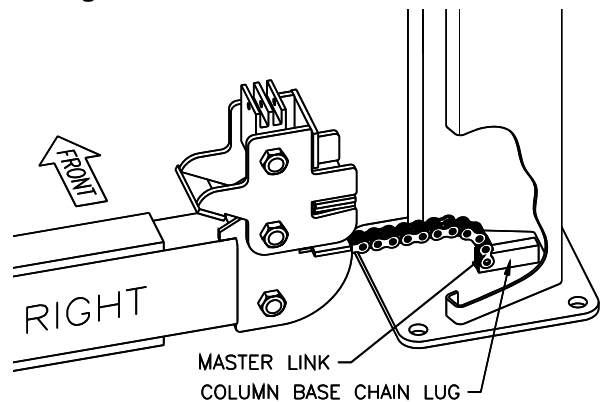

Fig 9 – Synchronizer Chain – Right Side

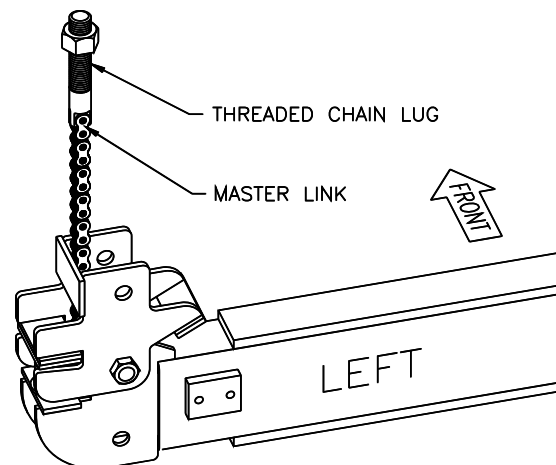

Fig 10 – Synchronizer Chain – Left Side

Model MDT Lube Rack System
Installation, Operation and Maintenance

- 15) Install one nut to the threaded end of each slack chain safety rod (leave 1 1/2" of thread exposed). Rotate and block up the right side slack chain latch to free the packing pin from the safety rod hole in the end of the crossbeam, **Fig 11**. Carefully remove the packing pin and install the slack-chain safety rod in its place. Slide the crossbeam and slack chain safety rod into the column and insert the threaded end of the safety rod up through the column top plate. Secure the rod with a second nut flush with the top of the rod and tighten the lower nut against the bottom of the top plate. Remove the latch blocking and repeat for the other crossbeam.

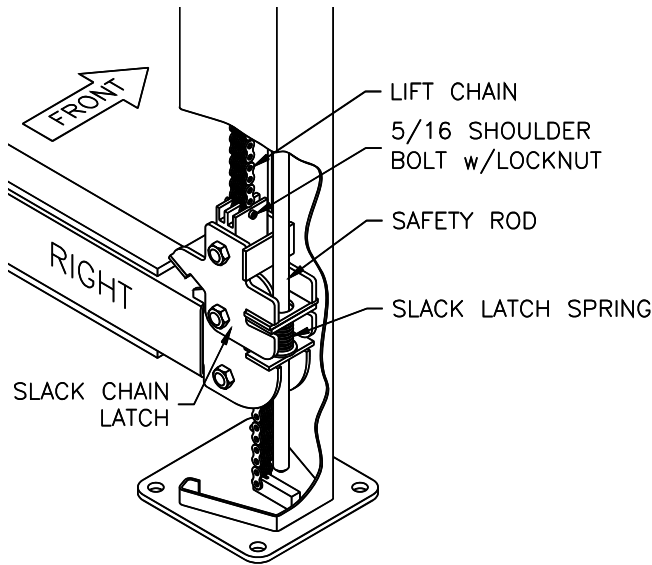

Fig 11 – Crossbeam / Column Assembly

- 16) Position both left side columns and repeat **step 15** for the left end of the crossbeams.
- 17) Attach the threaded synchronizer chain lug to the column top plate with one nut below the plate and one above. Remove all slack from the synchronizer chains by tightening the top nut.
- 18) If the measurements checked in **step 5** required repositioning right rear column, adjust the position of the left rear column by the same amount. Install both left side columns in the same manner as the right side referring to **steps 6 thru 11**.

- 19) Check the dimension from the inside of the two front columns measured at the base plate and at the top of the column, **Fig 12**. Adjust idler side shims if necessary. Repeat for rear columns.

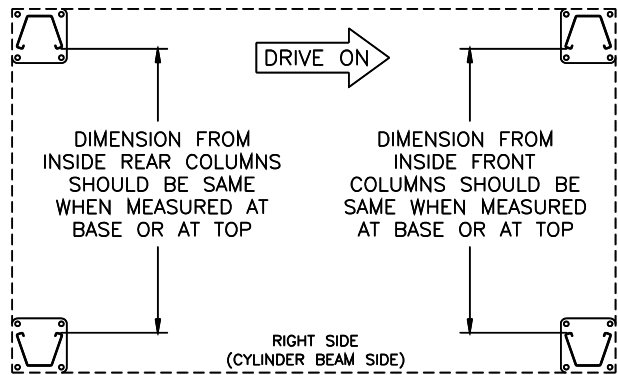

Fig 12 – Column Parallel Measurements

Model MDT Lube Rack System
Installation, Operation and Maintenance

POWER UNIT / ELECTRICAL

20) Clean front of power unit reservoir and apply Safety / Caution / Warning decals (furnished in literature package).

Note: if power unit reservoir already has decals on it, remove and apply supplied decals applicable to runway lifts, see **page 4**.

21) * Install power unit on right rear column. Remove steel pressure port plug, #6 O-ring port on left side when facing controls, and use it to replace the plastic shipping plug on the right side. Install #6 O-ring x #6 JIC elbow in left side pressure port, **Fig 13**. Remove plastic return port shipping plug, 3/8NPT on left side and install 3/8NPT steel plug, see **Fig 13**.

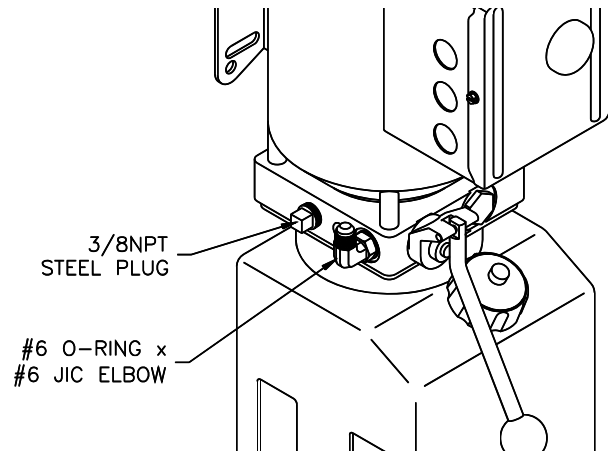

Fig 13 – Power Unit Connections

22) * Remove shipping plugs from both ends of hydraulic cylinder and manually extend cylinder rod. Install 3/8NPT breather plug at pinned clevis end of cylinder (rear of lift) and 3/8NPT x #6 JIC elbow at rod end. Attach the hydraulic hose (10' long with female #6 JIC both ends) to the elbow fitting at the power unit pressure port and the elbow at the rod end of the cylinder. Secure hose to cylinder with cable ties.

23) Attach both cylinder lift chains to crossbeam chain blocks using 5/16 shoulder bolt, **Fig 11**.

24) * Install flexible conduit assemblies to bottom side of both ends of cylinder beam. There are two different assemblies supplied – one with two (2) straight fittings, and one with a straight and an elbow fitting. Install the assembly with two (2) straight fittings at the power unit, and the assembly with the elbow fitting at the front of the cylinder beam, see **Fig 14**.

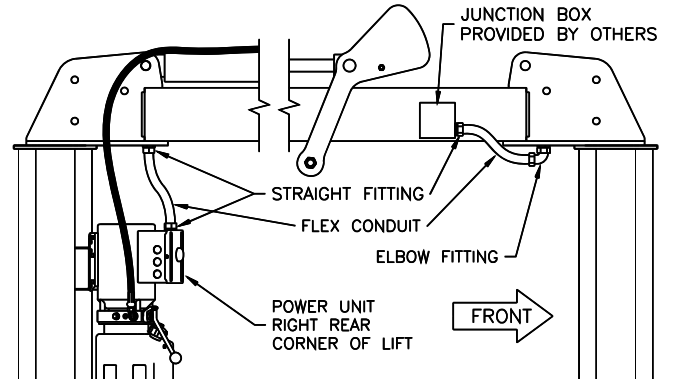

Fig 14 – Conduit Routing

25) Have a certified electrician connect the power unit to a suitable electrical power source. The standard power unit is 4HP, 208-230 volt, 60 Hz, single phase requiring a dedicated 30 amp double poll, double throw circuit breaker to operate lift at full capacity.

Note: Electrical drop should attach to the flexible conduit at the front end of the cylinder beam, **Fig 14**. **This connection must be made on the outside of the lift** (right side of the cylinder beam) to avoid interference with the catwalk rails.

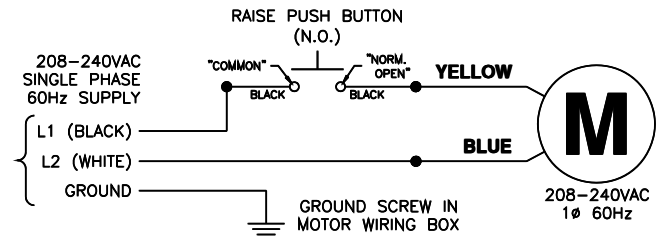

Fig 15 – Wiring Diagram

26) Fill the Power Unit with three gallons of clean 10wt anti-foam anti-rust hydraulic oil or Dexron III ATF. **Do NOT USE OILS WITH DETERGENTS.**

RUNWAYS

27) Position runways as indicated in the "Service Bay Layout" figure

- MDR2 installation see Fig 3A
- MDR3 & 4 installation see Fig 3B
- MDTN2 installation see Fig 4A
- MDTN3 & 4 installation see Fig 4B

with the oil pan channel toward the inside and the end of the runway with extra holes in the outside toe-board toward the front, see Fig 16.

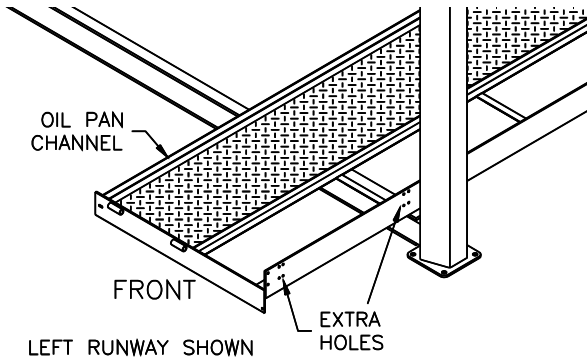

Fig 16 – Runway Orientation

28) * Loosely attach runways to crossbeams by connecting runway angle mounting tabs to crossbeam angle mounting tabs Fig 17 (four bolts per lift).

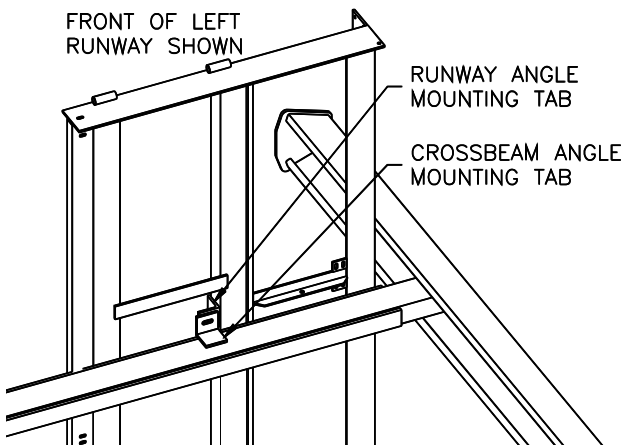

Fig 17 – Runway Attachment (as viewed from below looking up at bottom of runway)

29) Place center grate, marked "G-3", between runways, see Fig 37. Adjust runways fore-&-aft and center them left-to-right with the center grate holding the spacing between the runways.

30) * Push center grate back a few inches from the front of the runways and attach runway tie bar with one bolt and nut (see hardware list) at each end, Fig 18.

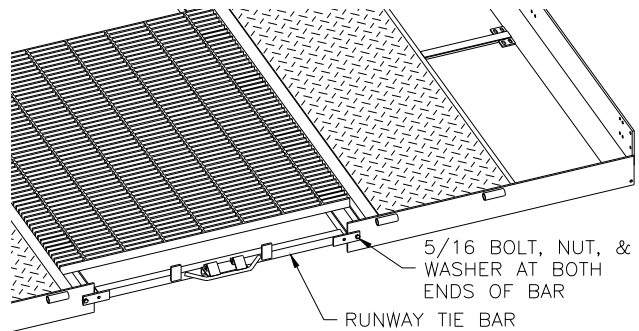

Fig 18 – Runway Tie Bar

31) Center fore-&-aft each crossbeam end inside its column. With the proper location of the runways in the bay and the crossbeams in the columns, the runway mounting bolts can now be tightened, Fig 17.

32) Raise lift to the top of its travel. Check the positioning of the crossbeams in the columns as the lift is raised. The single point primary lock release will move across the rack at the bottom of the cylinder beam. At the top of the lifts travel, pull down the lock until the cam holds it in the unlocked position. Lower the lift. Check the operation and positioning of the lift as it is being lowered.

33) Raise lift to comfortable height and install anti-sway bracket assemblies to guide the crossbeam ends centered in the columns, Fig 19.

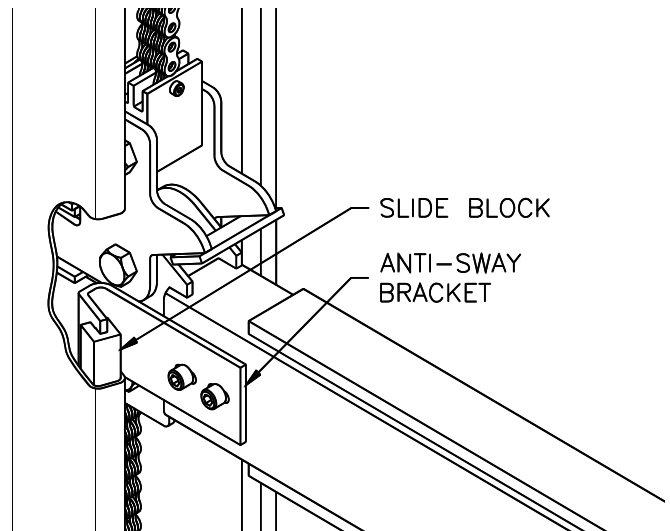

Fig 19 – Anti-Sway Brackets

34) Repeat steps 2 thru 33 for remaining lifts.

Model MDT Lube Rack System
Installation, Operation and Maintenance

PLATFORM

- 35) Position welded stairs near its installed location between the lifts (note: stair support tab toward front of lift with bottom edge of stringer formed inward), **Fig 20**.

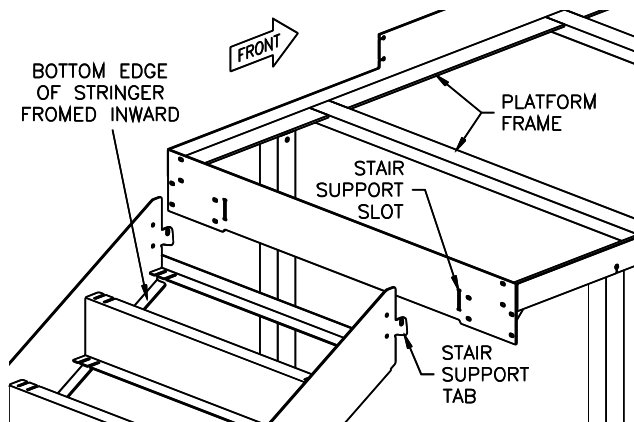

Fig 20 – Stair Support

- 36) Check the layout lines for the platform legs from **step 1**. Use a 4 ft. level to estimate shims required to level the legs (supplied shims and 1/2" anchors may accommodate as much as 1/2" shimming as close as 3 inches from any edge). If front leg anchors are closer than 3 inches from a front floor drain, the front legs may be moved rearward 4 1/2 inches.

- 37) Anchor and install platform legs using methods prescribed by **steps 6 – 9** with 1/2" wedge anchor bolts provided. Orient rear legs so the three tapped holes for the waste oil pump mount plate face forward.

Note: Recessed installs use two (2) 81" tall legs for the rear of the platform with two (2) 74" short legs for the front of the platform, while Non-Recessed installs use four (4) 81" tall legs.

- 38) Apply 80 ft-lbs setting torque to each anchor nut. Loosen (two turns) all eight (8) anchors on the two (2) right side legs to allow some movement when setting the platform frame.

- 39) Assemble the four platform frame sections (MDT2 ONLY) with (24) 3/8x1 flanged bolts and nuts, **Fig 21**.

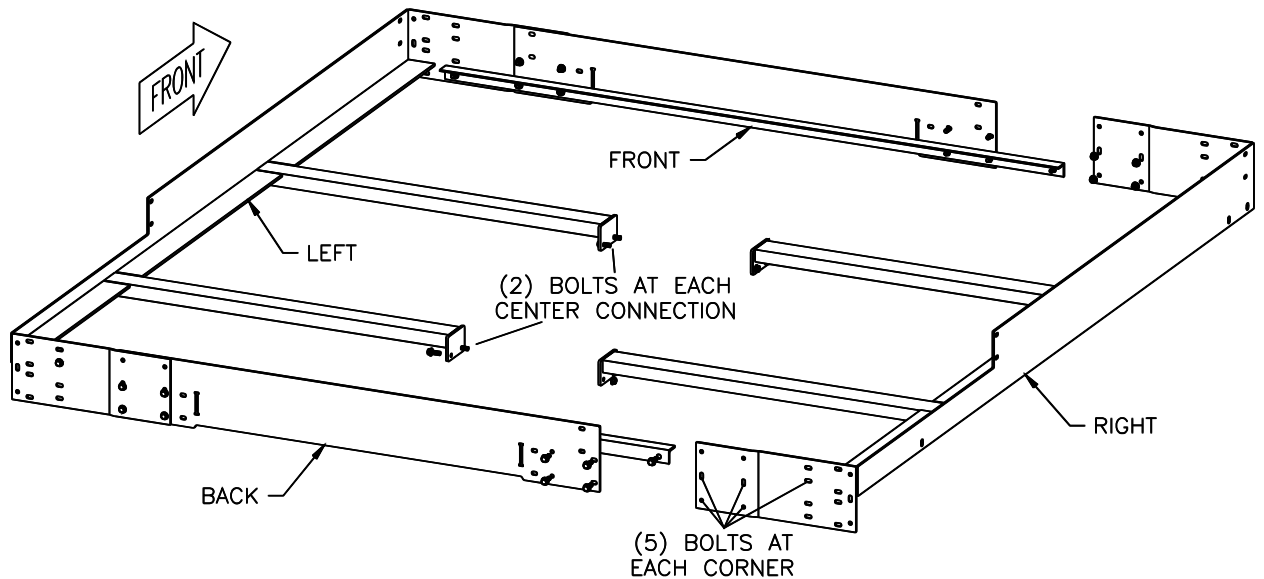

Fig 21 – Platform Frame Assembly - MDT_2 ONLY

- 40) * Raise platform frame to rest on top of legs and secure each leg with one 3/8 x 4" bolt. If front legs were moved rearward to avoid interference with floor drain, drill (7/16" dia.) platform side plate for new location.
- 41) Tighten right side post anchors and recheck plumb.
- 42) Repeat **steps 35 – 41** for multiple platforms.

- 43) Carefully raise lifts to ensure clearance between runway catwalks and platform frame at full rise (the gap between the outside of the platform frame and the outside of the catwalk should be approximately 1 1/2").

- 44) * Raise front of stairs, **Fig 20**, and fit stair support tabs into the slots in the rear face of the platform frame. Secure the stairs from inside the platform frame with 3/8 hardware, **Fig 22**.

Model MDT Lube Rack System
Installation, Operation and Maintenance

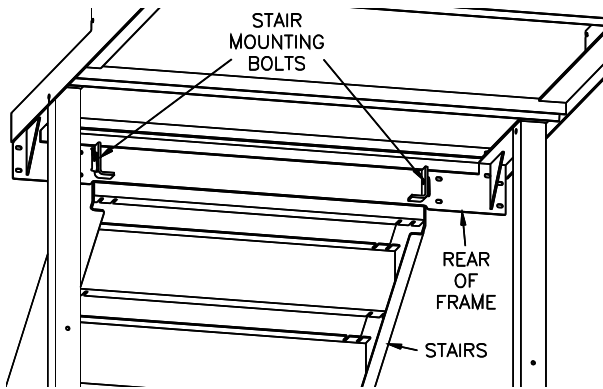

Fig 22 – Stair Attachment (as viewed from below platform frame looking up at bottom of stairs)

- 45) Starting at the bottom of the stairs, position and fasten each tread using two (2) 1/4" flat head phillips screws and two (2) fender washers on top of each tread at the back of the tread, **Fig 23**.

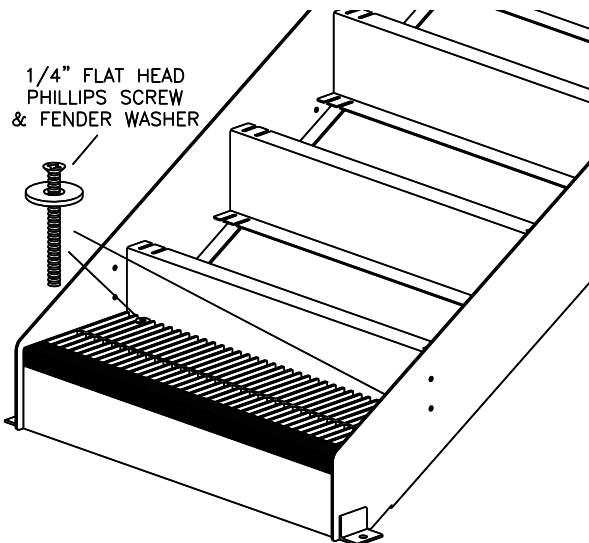

Fig 23 – Stair Treads

- 46) * Install 1/2" concrete wedge anchors at both bottom corners of stairs, **Fig 24**.
- 47) * Loosely fasten short and tall stair covers (note left and right) to the stairs and to each other with 1/4" hardware. Using the stair cover as a template, drill 1/4" x 2" deep holes and hammer the 1/4" flat head drive anchors in to secure the bottoms of the stair covers. Tighten stair cover hardware.

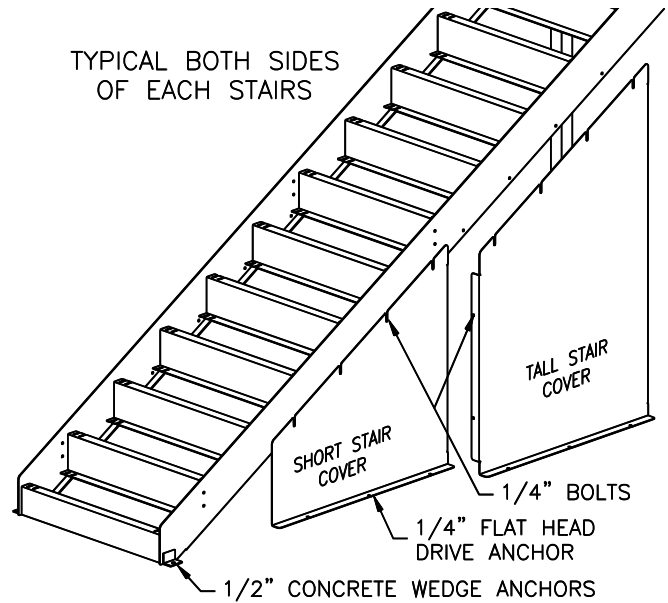

Fig 24 – Stair Covers

- 48) * Install waste oil pump mounting plate to the rear platform legs with 3/8 hardware, **Fig 25**.

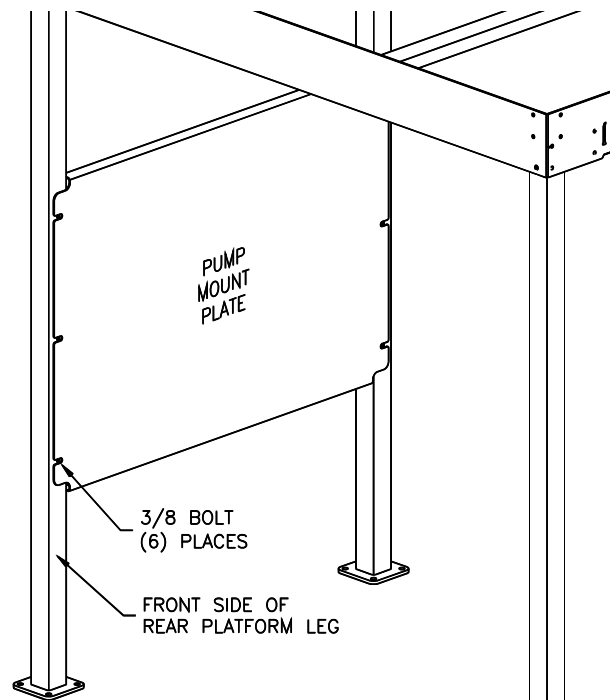

Fig 25 – Pump Mount Plate

- 49) Place remaining walkway grating on runway catwalk and platform, see **Fig 37**.

RAILING (ALL RAILING ATTACHES TO THE INSIDE OF THE TOE-BOARD ABOVE THE GRATING WITH THE WIRE MESH ON THE OUTSIDE OF THE RAIL)

- 50) * Install platform front rail (51 3/4") and side rails (61 5/8"). Connect both ends of the front rail to the front of each side rail with a rail angle bracket, **Fig 26**.

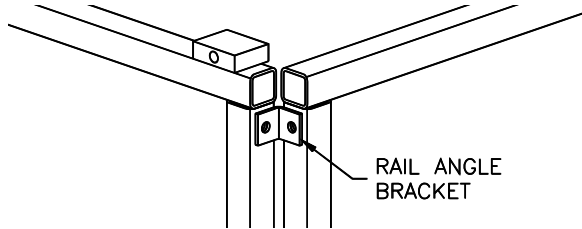

Fig 26 – Platform Rail Corner

- 51) * Install the two (2) platform back rails (8"). Note that this is the only rail that does not bolt to the inside of the toe-board, but instead bolts to the outside of the platform and has the toe-board built into the rail. Connect the drop-gate bar to both side rails and ensure that it latches against back rail, **Fig 27**.

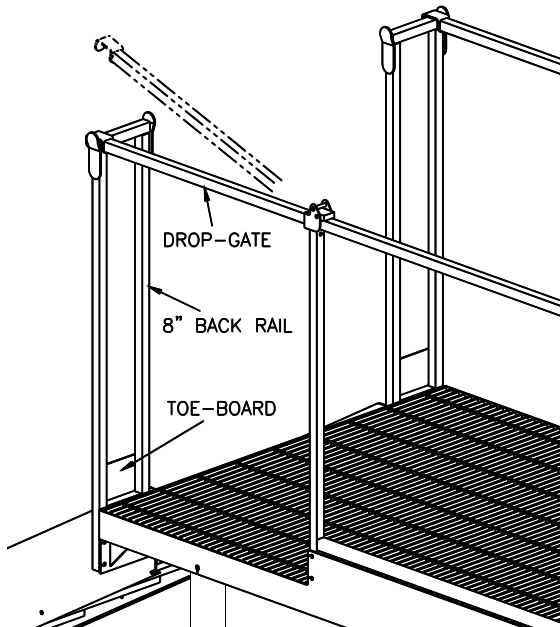

Fig 27 – Drop-Gate

- 52) * Install both stair rails, one left and one right.
53) * Install two (2) runway rails (103 3/8") per runway starting at the rear of the runway. This leaves an opening from the runway to the platform when the lift is raised. Install one (1) runway filler rail (36 1/4") to the two runways that are not adjacent to a platform.

RAMPS

- 54) * Attach a ramp to the front and rear of each runway, see **Fig 1 – General Specifications**

- **MDTR** ramps are identical for left and right runways, but different from front to rear. The front ramps are 51 1/4" wide. Attach each to runway with (1) ramp hinge pin and two (2) cotter pins. The rear ramps are 38" wide and have two hinge tubes to allow it to be hung from the left or right runway. Attach each rear ramp, along with a 3" hinge tube spacer, to each runway using (1) ramp hinge pin and two (2) cotter pins, see **Fig 28**. Attach one (1) 20" ramp slide and one (1) 10 1/2" ramp slide to both rear ramps, **Fig 29**. Attach two (2) 20" ramp slides to both front ramps
- **MDTN** ramps are all identical left, right, front, & rear. Secure each with one (1) ramp hinge pin and two (2) cotter pins.

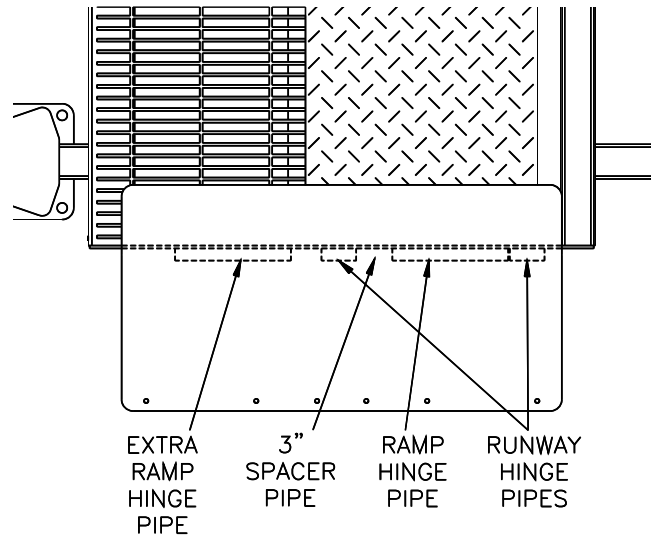

Fig 28 – Rear Ramp Hinge Spacer (left side shown)

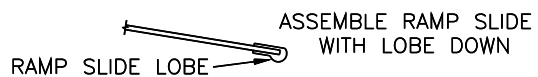
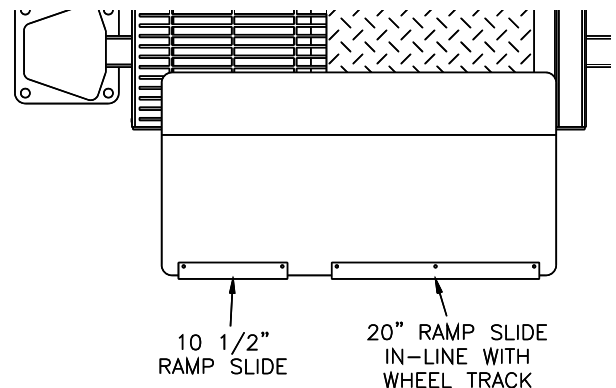

Fig 29 –Rear Ramp Slides (left runway shown)

FRONT GATES

- 55) * Insert one (1) gate latch with roller into each gate and latch handle assembly. Secure with 3/16" diameter roll pin, **Fig 30**.

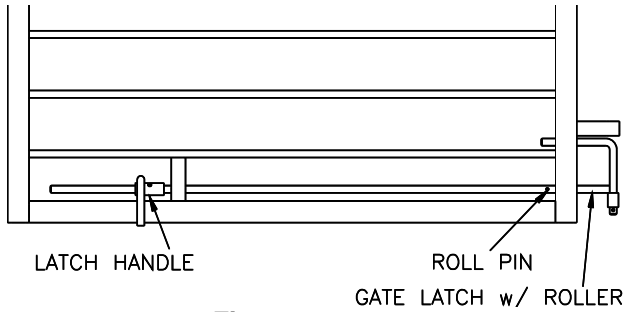

Fig 30 – Gate Assembly

- 56) * Attach one gate post to the front of each runway (note that each lift uses two (2) different gate posts – one for left and one for right), **Fig 31**.

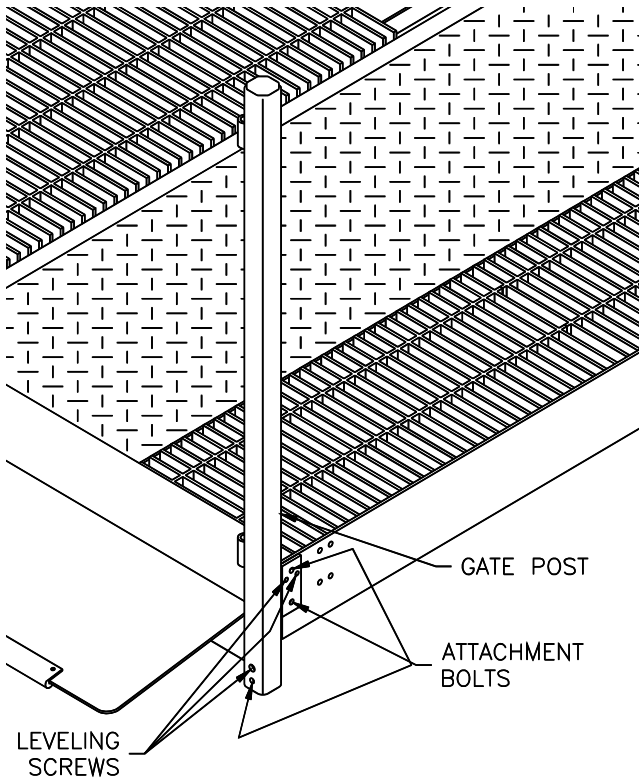

Fig 31 – Gate Post (front left corner of MDTR shown)

- 57) * Install one gate-open latch to the platform leg in front of each gate post.
- **MDTR** gate open latches fasten to the outer-rear anchor of the front platform leg. Remove the concrete anchor nut and install latch, see **Fig 32**.
 - **MDTN** gate open latches fasten to both rear anchors of the front platform leg. Place a 1/2" external tooth lock washer between the top plates of the gate-open latch and the support channel and loosely attach top holes with 1/2" hardware. Remove the concrete anchor nuts. Insert a second 1/2" external tooth lock washer between the bottom plates of the gate-open latch and the support channel and place the assembly over the leg anchor bolts. Reinstall anchor nuts, **Fig 32**.

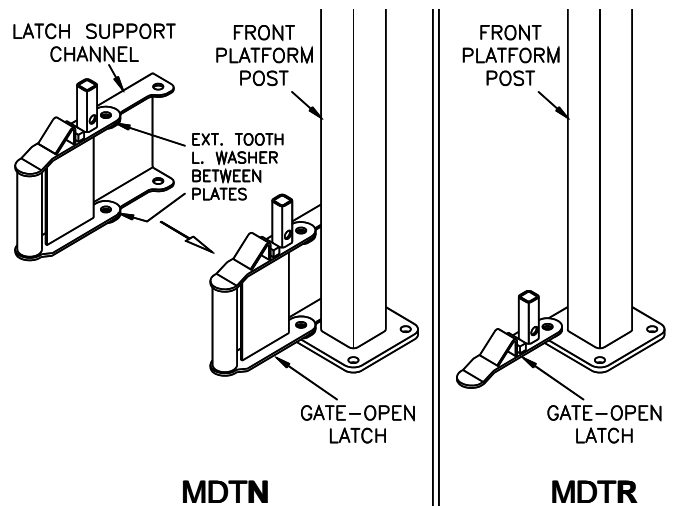

Fig 32 – Gate Assembly

- 58) * Install one gate-open post for the two (2) front gates that do not swing against a platform leg, refer to corresponding "Service Bay Layout".
- **MDTR2** installation see **Fig 3A**
 - **MDTR3 & 4** installation see **Fig 3B**
 - **MDTN2** installation see **Fig 4A**
 - **MDTN3 & 4** installation see **Fig 4B**

- 59) Install gate assemblies (left and right are identical). Level all gates in the closed position and in the open position. Gates should close evenly and latch fully when open or closed. Loosen gate post bolts, adjust gate post leveling screws, and retighten gate post bolts. Repeat as necessary. Adjust the upper leveling screws with the gate closed and lower screw with the gate open.

Model MDT Lube Rack System
Installation, Operation and Maintenance

RUNWAY AIR LINE

- 60) Assemble "T" fitting (1/4NPT FxFxM), union elbow (1/4NPT x 1/4 tube), union (1/4NPT x 1/4 tube), and bulkhead bracket, **Fig 33**, one (1) assembly per lift.

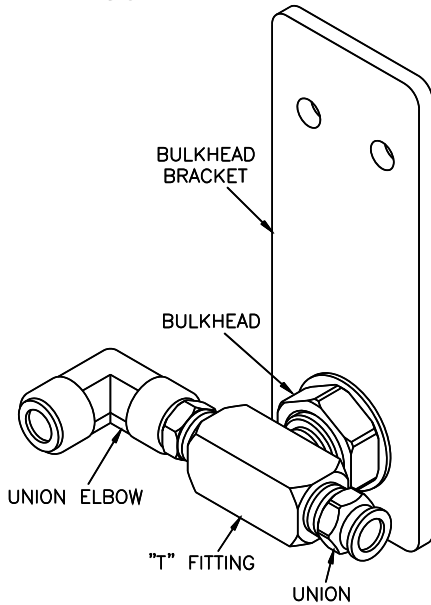

Fig 33 – Gate Assembly

- 61) * Attach one bulkhead bracket assembly to each lift near the front on the side adjacent to the platform (if lift has a platform on each side attach bracket to the left runway), **Fig 34**.

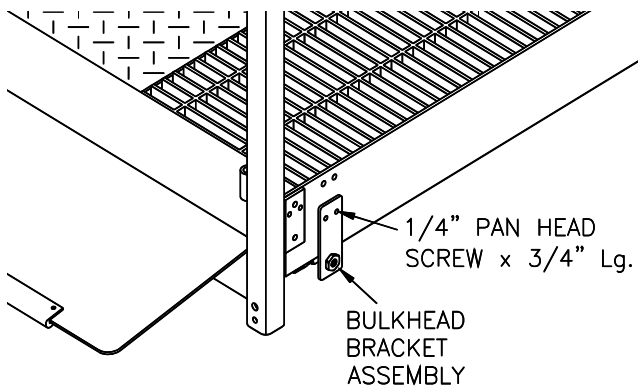

Fig 34 – Air Line Bulkhead Bracket (front left corner of MDTR shown)

- 62) Route two (2) air lines from each bracket assembly, one for each runway, under the catwalk grating and cut just past the fourth grating support bracket (approximately 12 ft. from front of runway), **Fig 35**. Route air line through hole in center of grating support brackets. Attach union fitting and 1/4NPT pipe coupling to loose end.

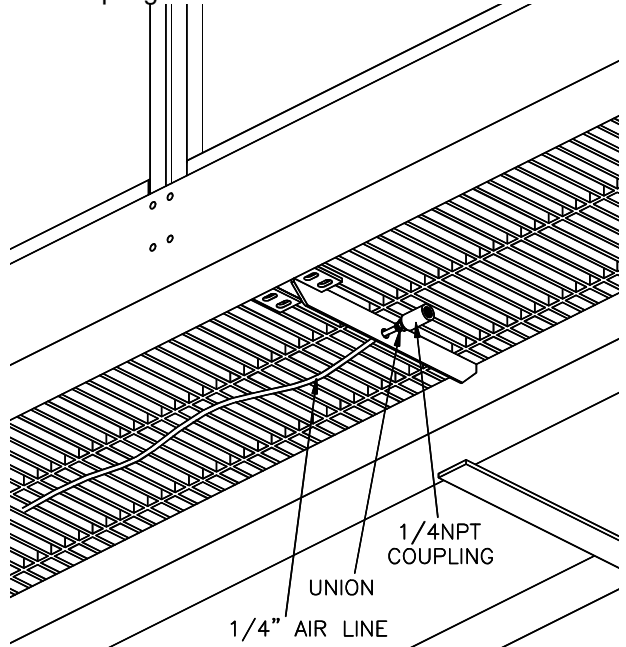

Fig 35 – Air Line Coupling (bottom view, left runway)

GRATING

- 63) Fasten runway center grate and catwalk grating, **Fig 37**.

Model MDT Lube Rack System
Installation, Operation and Maintenance

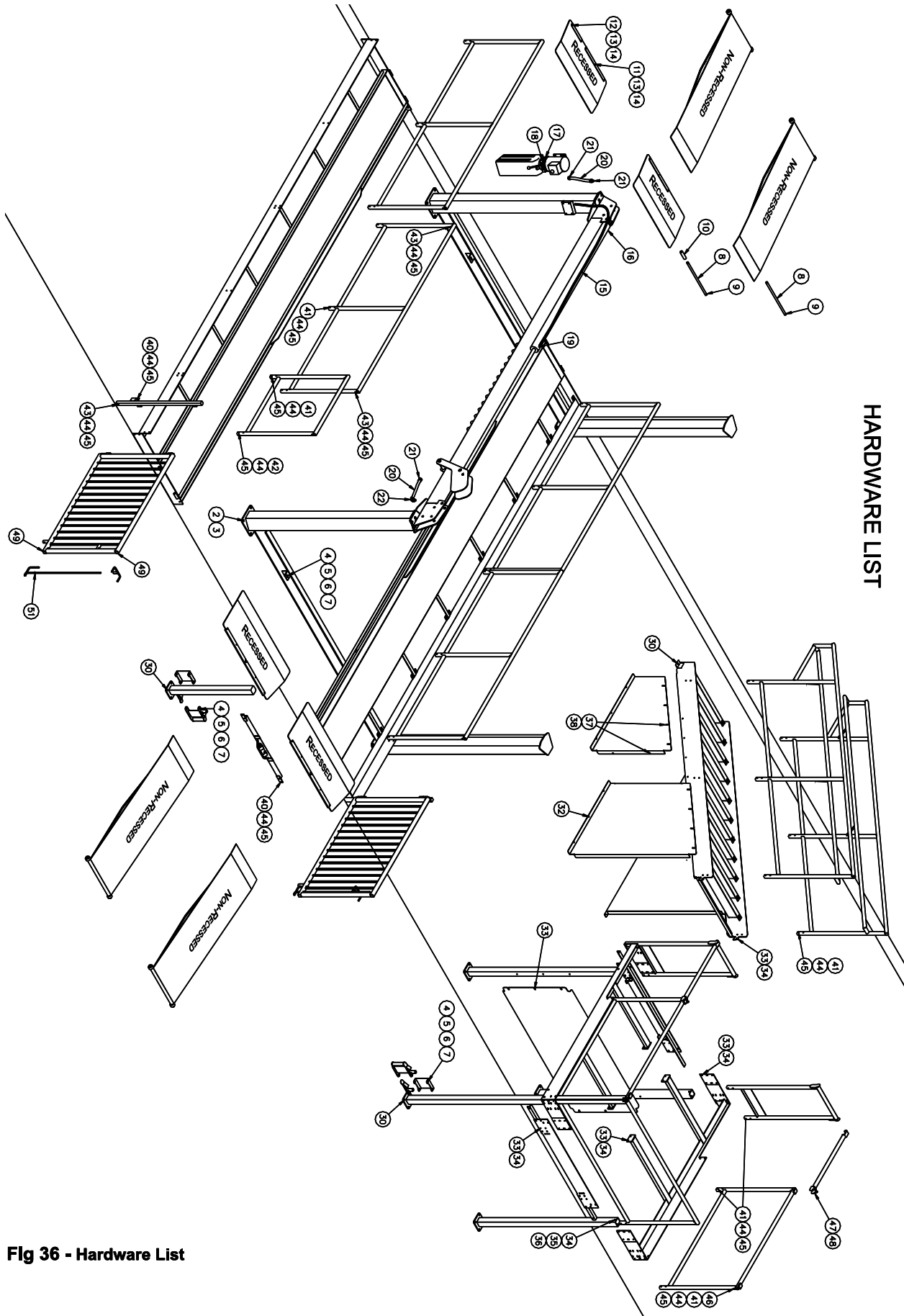

Fig 36 - Hardware List

Model MDT Lube Rack System
Installation, Operation and Maintenance

Table 3 – Hardware List

ITEM #	44730-L QTY / LIFT	44730-P QTY / PLTFRM	44730-S QTY / STORE	44731-R QTY / LIFT	44731-N QTY / LIFT	P/N	DESCRIPTION	WHERE USED
LIFT								
1	1					44734	LITERATURE PACK (MDT)	
2	16					31058	3/4" x 5 1/2" Lg. ANCHOR	4 per 4 LIFT COLUMNS
3	2					480589	SHIM KIT	
4	4				2	40083	1/2-13NC x 1 1/4 HX.FLG.HD.C.S.	RUNWAY to XBEAM LATCH PLATE WELD (Gate-Open Non-Reces'd)
5	4				2	16159	1/2-13NC HEX NUT	RUNWAY to XBEAM LATCH PLATE WELD (Gate-Open Non-Reces'd)
6	4				4	16158	1/2" EXTERNAL TOOTH L.WASHER	RUNWAY to XBEAM LATCH PLATE WELD (Gate-Open Non-Reces'd)
7	4				2	31014	1/2" FLAT WASHER	RUNWAY to XBEAM LATCH PLATE WELD (Gate-Open Non-Reces'd)
8				4	4	40165	3/4" RAMP HINGE PIN	
9				8	8	40126	1/8 x 1 1/2 COTTER PIN	RAMP HINGE PIN
10				2		44768-03	3" SPACER (REAR Recessed RAMP)	
11				6		40168	RAMP SLIDE	
12				2		44769	10 1/2" RAMP SLIDE	REAR RAMPS @ CATWALK
13	2			22		31062	1/4-20NC x 3/4 PAN HD SCREW	3 per RAMP SLIDE + 2 per AIR LINE BRACKET
14	2			22		40085	1/4-20NC HEX.FLG.NUT	3 per RAMP SLIDE + 2 per AIR LINE BRACKET
15	1					A2127-P	HYDRAULIC HOSE	
16	1					66026	3/8 NPT BREATHER	CYLINDER TAIL PORT
17	1					44707	3/8 NPT MALE HOLLOW HEX PLUG	POWER UNIT RETURN LINE PORT
18	1					16167	90 deg ELBOW #6 O-RING x #6 JIC	POWER UNIT PRESSURE PORT
19	1					68032	90 deg ELBOW 3/8 NPT x #6 JIC	CYLINDER GLAND PORT
20	2					44712	LIQUID TITE CONDUIT, 1/2" (11.5")	
21	3					44714	LIQUID TITE STRAIGHT FITTING	
22	1					44715	LIQUID TITE ELBOW FITTING	
23	1					40235	1/4NPT BULKHEAD	
24	1					44724	BULKHEAD BRACKET	
25	1					40236	1/4NPT "T" MALE-F-F	
26	3					16513	UNION 1/4NPT x 3/8 TUBE	
27	1					40234	UNION ELBOW 1/4NPT x 3/8 TUBE	
28	2					44720	1/4NPT COUPLING	
29	35					40233	3/8" O.D. AIR LINE (ft.)	
PLATFORM								
30		18				68029	1/2-13 x 3 3/4" ANCHOR	4 per 4 PLATFORM LEGS + 2 per STAIR BASE 4 per 2 GATE-OPEN POSTS
			8					
32		12				484985	1/4" x 1 1/2 FLAT HD DRIVE ANCHOR	3 per 4 STAIR SIDE SHIELDS
33		8				12568	3/8 x 1 HX.FLG.HD.C.S.	1 per 2 STAIR TANGS + 6 per MOUNTING PLATE *MDT_2 ONLY* 24 per PLATFORM FRAME ASS'Y
		24						
34		6				A1154	3/8 HEX FLG NUT	2 STAIR TANG / 4 LEG to PLATFORM *MDT_2 ONLY* 24 per PLATFORM FRAME ASS'Y
		24						
35		4				44721	3/8 x 4 H.H.C.S.	LEG to PLATFORM
36		4				31036	3/8 FLAT WASHER	LEG to PLATFORM
37		20				A2125	1/4-20NC x 3/4 HX.FLG.HD.CAP SCREW	STAIR SIDE PLATES 5 per 4 PLATES
38		20				40085	1/4-20NC HEX.FLG.NUT	STAIR SIDE PLATES 5 per 4 PLATES

(continued on next page)

Model MDT Lube Rack System
Installation, Operation and Maintenance

Table 3 – Hardware List (continued)

ITEM #	44730-L QTY / LIFT	44730-P QTY / PLTFRM	44730-S QTY / STORE	44731-R QTY / LIFT	44731-N QTY / LIFT	P/N	DESCRIPTION	WHERE USED
RAIL								
40	6					44722	5/16 x 1 1/4 H.H.C.S.	2 per 2 GATE POSTS + 2 per GATE-CLOSED LATCH
41	24	36				44207	5/16 x 2 H.H.C.S.	2 per 12 RUNWAY POST + 2 per 6 STAIR POST; 2 per 10 PLATFORM POST + 2 per 2 CORNER ANGLE BRACKETS
			4					2 per 2 FILLER PANEL
42			4			44208	5/16 x 2 1/2 H.H.C.S.	2 per 2 FILLER PANEL
43	5					44723	5/16 x 3 H.H.C.S.	3 per LIFT TO SPLICE RAIL PANELS; 1 per 2 GATE POST
44	35	36				31330	5/16 FLAT WASHER	1 per BOLT
			8					4 per 2 FILLER PANEL
45	35	36				4100237	5/16 HEX.FLG.NUT	1 per BOLT
			8					4 per 2 FILLER PANEL
46		2				44823	RAIL CORNER ANGLE BRACKET	PLATFORM
47		2				A1157	3/8-16NC x 2 1/2 H.H.C.S.	DROP-GATE PIVOT
48		2				A1139	3/8-16NC NYLON INSERT JAM NUT	DROP-GATE PIVOT
49	4					44210	1 1/2" SQ TUBE CAP	2 per 2 GATE
51	2					061-181	3/16 x 3/4 ROLL PIN	2 per 2 LATCH ASSEMBLIES
FLOOR GRATING								
55	28	22				44727	1/4-20NC x 2 1/2" FLAT PHIL.HD.SCREW	2 per 11 STEPS + 2 per 14 RWAY GRTS
56	4					44728	1/4-20NC x 3 1/2" FLAT PHIL.HD.SCREW	4 per CENTER GRATE
57	32	22				44729	M10 FLT.WASH. 10.5x30x2.5Tk	
58	32	22				40085	1/4-20NC HEX NUT	

Fiberglass Grating Layout

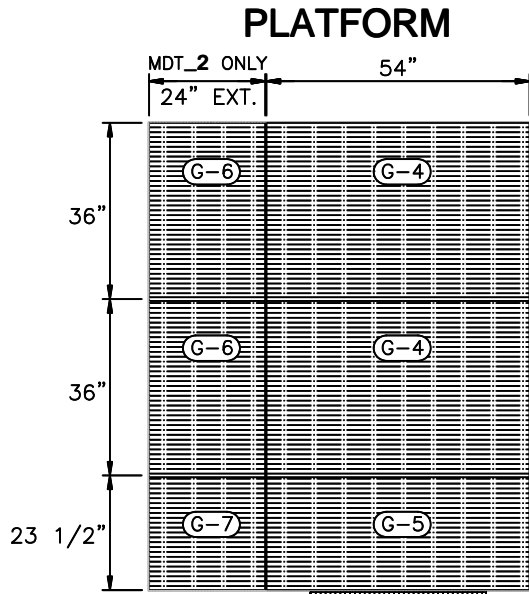

KIT #	P/N	SIZE	QTY/LIFT	QTY/PLATFORM
44705 LIFT	44705-G-1	18 x 36	12	
	44705-G-2	18 x 26	2	
	44705-G-3	44 x 51	1	
44706 PLATFORM	44705-G-4	36 x 54		2
	44705-G-5	23 1/2 x 54		1
	44705-T-1	12 x 36		11
44704W PLATFORM	EXTENSION GRATING FOR MDT_2 ONLY (79" WIDE PLATFORM)			
	44704W-G-6	36 x 24		2
	44704W-G-7	23 1/2 x 24		1

STAIRS

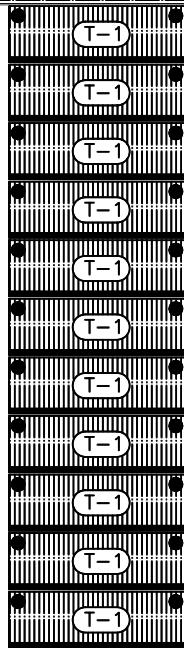

FASTENING INSTRUCTIONS

- USE ONE (1) 1 1/8" O.D. HEAVY FLAT WASHER WITH ONE (1) 1/4-20NC FLAT HEAD SCREW ON TOP OF THE GRATING WITH ONE (1) 1/4-20NC FLANGE NUT BELOW.
- ANCHOR AT LOCATIONS INDICATED BY "●"
- USE 2 1/2" Lg SCREWS AT ALL LOCATIONS EXCEPT THE G-3 PANEL

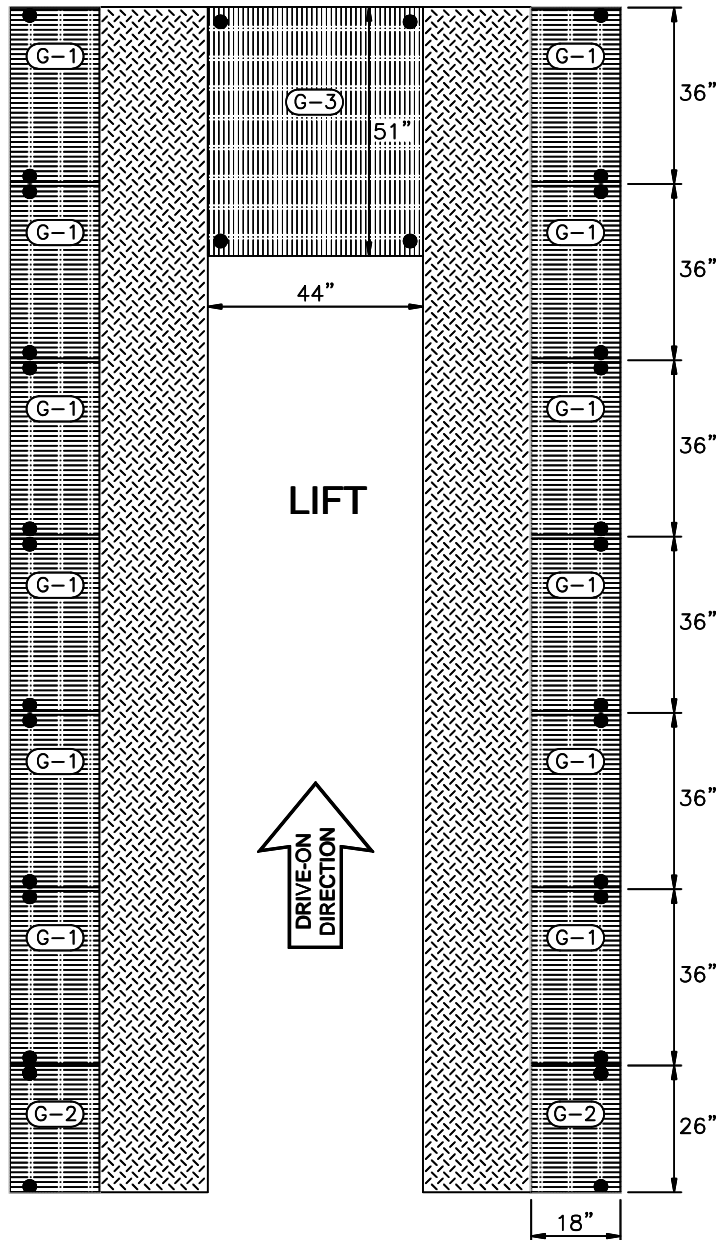

Fig 37 - Fiberglass Grating Layout

Owner/Operator Checklist

SAVE THESE INSTRUCTIONS deliver them to owner/user/employee along with other materials furnished with this lift.

Demonstrate the operation of the lift to the owner/operator and review correct and safe lifting procedures using the **Lifting It Right** booklet as a guide.

Complete the Installation Checklist/Warranty Validation questionnaire with the owner. Review the terms of the warranty registration card, and return the card and a copy of the questionnaires to:

Challenger Lifts, Inc.
200 Cabel Street
Louisville, KY. 40206

Safety Notices and Decals

This product is furnished with graphic safety warning labels, which are reproduced on page 3 of these instructions. Do not remove or deface these warning labels, or allow them to be removed or defaced. For your safety, and the safety of others, read and understand all of the safety notices and decals included.

Owner/Employer Responsibilities

This lift has been designed and constructed according to ANSI/ALI ALCTV-1998 standard. The standard applies to lift manufactures, as well as to owners and employers. The owner/employer's responsibilities as prescribed by ANSI/ALI ALOIM-2000, are summarized below. For exact wording refer to the actual standard provided with this manual in the literature pack.

The Owner/Employer shall insure that lift operators are qualified and that they are trained in the safe use and operation of the lift using the manufacturer's operating instructions; ALI/SM 93 - 1, ALI Lifting it Right safety manual; ALI/ST-90 ALI Safety Tips card; ANSI/ALI ALOIM-2000, American National Standard for Automotive Lifts-Safety Requirements for Operation, Inspection and Maintenance; ALI/WL Series, ALI Uniform Warning Label Decals/Placards; and in case of frame engaging lifts, ALI/LP-GUIDE, Vehicle Lifting Points/Quick Reference Guide for Frame Engaging Lifts.

The Owner/Employer shall establish procedures to periodically inspect the lift in accordance with the lift manufacturer's instructions or ANSI/ALI ALOIM-2000, American National Standard for Automotive Lifts-Safety Requirements for Operation, Inspection and Maintenance; and the

employer shall insure that the lift inspectors are qualified and that they are adequately trained in the inspection of the lift.

The Owner/Employer shall establish procedures to periodically maintain the lift in accordance with the lift manufacturer's instructions or ANSI/ALI OIM-2000, American National Standard for Automotive Lifts-Safety Requirements for Operation, Inspection and Maintenance; and the employer shall insure that the lift maintenance personnel are qualified and that they are adequately trained in the maintenance of the lift.

The Owner/Employer shall maintain the periodic inspection and maintenance records recommended by the manufacturer or ANSI/ALI ALOIM-2000, American National Standard for Automotive Lifts-Safety Requirements for Operation, Inspection and Maintenance.

The Owner/Employer shall display the lift manufacturer's operating instructions; ALI/SM 93 - 1, ALI Lifting it Right safety manual; ALI/ST-90 ALI Safety Tips card; ANSI/ALI ALOIM-2000, American National Standard for Automotive Lifts-Safety Requirements for Operation, Inspection and Maintenance; and in the case of frame engaging lift, ALI/LP-GUIDE, Vehicle Lifting Points/Quick Reference Guide for Frame Engaging Lifts; in a conspicuous location in the lift area convenient to the operator. Demonstrate the operation of the lift to the owner and review correct and safe lifting procedure, using the "Lifting It Right " booklet as a guide.

IMPORTANT SAFETY INSTRUCTIONS

When using your garage equipment, basic safety precautions should always be followed, including the following:

1. Read all instructions.
2. Care must be taken as burns can occur from touching hot parts.
3. To reduce the risk of fire, do not operate equipment in the vicinity of open containers of flammable liquids (gasoline).
4. Keep hair, loose clothing, fingers, and all parts of body away from moving parts.
5. Use only as described in this manual. Use only manufacturer's recommended attachments.
6. ALWAYS WEAR SAFETY GLASSES. Everyday eyeglasses only have impact resistant lenses, they are not safety glasses.

SAVE THESE INSTRUCTIONS

LIFTING A VEHICLE

Drive vehicle onto lift. Set parking brake and/or use wheel chocks that are provided with lift.

When the vehicle has reached the desired working height, release the power pack button, and lower the vehicle until the safety locks are engaged. The vehicle should remain level when all locks are engaged. If one side engages and the other continues to descend, stop lowering the vehicle, raise it several inches, and try again to engage locks.

IMPORTANT, Before walking under the lift insure that all locks are properly engaged.

It is not safe to work under the vehicle unless all locks are engaged, and the vehicle is level.

LOWERING A VEHICLE

Insure that the area under the vehicle is clear of personnel and tools.

Raise the vehicle until locks are free.

Disengage the locks by depressing the palm button and holding it.

Lower the vehicle by depressing the lowering valve handle. Watch lift to insure that the lift is lowering evenly. If not, raise lift and check all locks to insure they are disengaged before trying to lower lift again.

Continue to lower the vehicle until the crossbeams stop against the base plate. It is important to fully lower the lift to release hydraulic pressure on the system.

MAINTENANCE

To avoid personal injury, permit only qualified personnel to perform maintenance on this equipment.

The following maintenance points are suggested as the basis of a preventive maintenance program. The actual maintenance program should be tailored to the installation. See ANSI/ALI ALOIM booklet for periodic inspection checklist and maintenance log sheet.

- If lift stops short of full rise or chatters, check fluid level (with lift fully lowered).
- Replace all Safety, Warning or Caution Labels if missing or damaged.

Daily

- Keep lift components clean.
- Check for loose or broken parts.
- Check hydraulic system for fluid leaks.
- Check function of lock and lock release mechanism.

Weekly

- Check chains and sheaves for wear or damage. Replace as required with genuine Challenger Lifts parts.
- Inspect lock mechanism for proper function.

Monthly

- Torque lift column concrete anchor bolts to 80 ft-lbs.
- Clean and inspect chains and sheaves for wear or damage. Lubricate chains and sheaves with light oil.
- Visually inspect concrete floor for cracks and/or spalls within 12" of base plate

IMPORTANT ! Failure to keep lift free of corrosive agents and solvents will lead to reduced service life, which could result in property damage and/or personal injury.

If any problems are encountered, contact your local service representative.